



Hip and Ridge™

Application Instructions

ENGLISH

IMPORTANT MESSAGE • PLEASE READ! Products must be applied properly. They are designed for use as hip and ridge shingles only, and should not be used for any other applications. We assume no responsibility for leaks or defects resulting from poor application or failure to properly prepare the surface to be roofed over, or failure provide proper ventilation in accordance with minimum property standards requirements. Review all applicable building codes, minimum property standards, and requirements prior to applying these shingles. Use caution when stacking bundles on sloped roofs.

STEPS 1-3

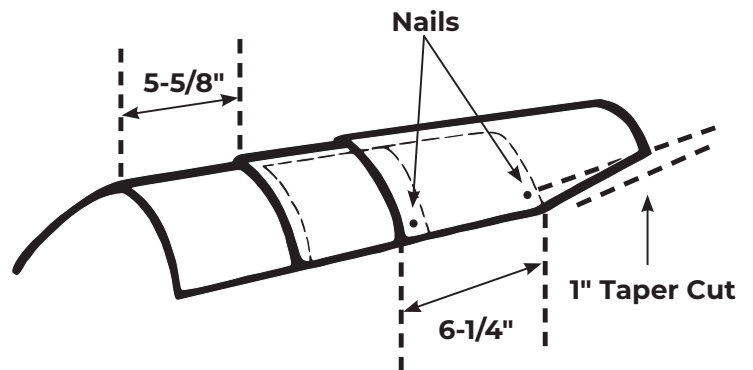
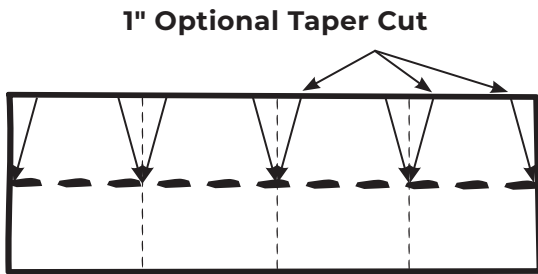
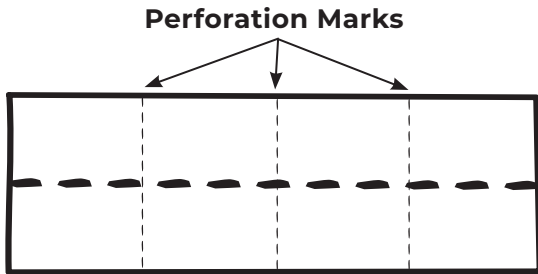

STEP 1:

INSTALL SHINGLES: Follow instructions on the wrapper.

STEP 2:

INSTALL HIPS AND RIDGES: Cut Hip and Ridge shingles into fourths, using the perforation marks as a cutting guide. For a neater appearance, the top 6" of each side of each piece can be trimmed on a 1" taper (see drawing).

STEP 3:

BEND EACH PIECE OVER THE HIP OR RIDGE: Nail 6-1/4" above the butt edge, 1" in from each edge, exposing each piece 5-5/8" to the weather.

STEP 4

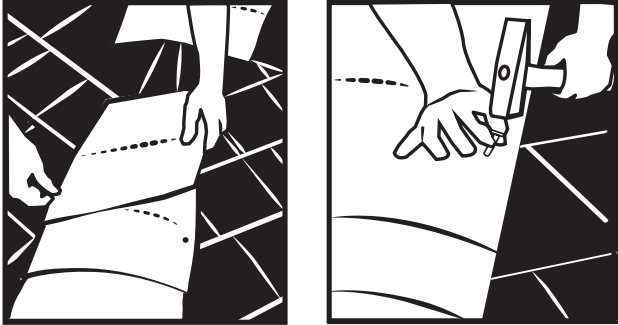

STEP 4:

APPLY HIP PIECES: Start at the lower end of the hip, working up toward the ridge. On hip roofs, apply ridge pieces starting at each end, meeting in the middle. On gable roofs, apply ridge pieces starting at the end opposite to the prevailing wind direction and continue to the other end.

STEP 5:

SET THE FINAL SHINGLE IN ROOFING CEMENT: Cover the exposed nail heads of the final shingle with roofing cement. Prior to application in cold weather, storing the shingles in a heated area will allow for easier bending.

IMPORTANT MESSAGE • PLEASE READ!

FASTENERS: Nails must be 11 or 12-gauge roofing nails, corrosion-resistant, with at least 3/8" heads, and at least 1-1/2" long. For decks 3/4" thick or thicker, nails must go at least 3/4" into the deck. On thinner decks, nails must go at least 1/8" through the deck.

