



TRUS JOIST[®] RIM BOARD

Featuring TJ[®] Rim Board and TimberStrand[®] LSL

- Multiple thicknesses, grades, and products to cover all your rim board needs
- 1 $\frac{1}{4}$ " Thickness matches lateral load capacity of 2x nominal sawn lumber in diaphragms
- Limited product warranty





The products in this guide are readily available through our nationwide network of distributors and dealers. For more information on other applications or other Trus Joist® products, contact your Weyerhaeuser representative.

Code Evaluations:
ICC-ES ESR-1387

TABLE OF CONTENTS

Material Weights	2
Lateral Load Capacity	3
Rim Board Installation Detail	3
Design Properties	4
Nailing on Narrow Face	4
Allowable Holes	4
Exterior Deck Attachment	5
Header Application	5
Allowable Vertical Loads	5
Load Tables:	
1-Ply Rim Board	6
2-Ply Rim Board	7
Multiple-Member Connections	7



Certified Sourcing

www.forests.org
SFI-00008

Benefits of Trus Joist® Rim Board

- Longer lengths for faster installation and fewer joints
- Depths are sized to match TJI® joists—less cutting and material waste when used together
- High vertical load transfer capacity
- Recognized and accepted by major building codes

For years, little attention was paid to the importance of lateral forces. However, recent earthquake and hurricane disasters have demonstrated the importance of proper lateral load transfer. Engineering analysis confirms that rim board is essential in a home's ability to resist the lateral loads generated by high winds and earthquakes.

Trus Joist® rim board products offer vertical load support and provide the nailing surface necessary to adequately transfer wind and seismic loads. Manufactured by Weyerhaeuser according to strict quality assurance requirements, they provide strength, stiffness, and durability. We're so confident about the performance of all our rim board that it comes with a limited lifetime product warranty. When used with TJI® joists, it offers the ultimate high performance floor.

Available Sizes

Trus Joist® Product	Depth							
	9½"	11⅞"	14"	16"	18"	20"	22"	24"
1⅞" TJ® Rim Board	•	•	•	•				
1¼" 1.3E TimberStrand® LSL	•	•	•	•	•	•	•	•
1½" 1.3E TimberStrand® LSL	•	•	•	•	•	•	•	•
1¾" 1.55E TimberStrand® LSL	•	•	•	•				
3½" 1.55E TimberStrand® LSL	•	•	•	•				

Some sizes may not be available in your region.

Approximate Material Weights (plf)

Trus Joist® Product	Depth							
	9½"	11⅞"	14"	16"	18"	20"	22"	24"
1⅞" TJ® Rim Board	2.9	3.6	4.3	4.9				
1¼" 1.3E TimberStrand® LSL	3.5	4.3	5.1	5.8	6.6	7.3	8.0	8.8
1½" 1.3E TimberStrand® LSL	4.2	5.2	6.1	7.0	7.9	8.8	9.6	10.5
1¾" 1.55E TimberStrand® LSL	5.2	6.5	7.7	8.8				
3½" 1.55E TimberStrand® LSL	10.4	13.0	15.3	17.5				

PRODUCT STORAGE

Protect product from sun and water

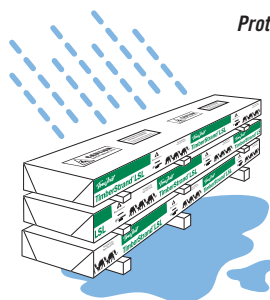

CAUTION:
Wrap is slippery when wet or icy

Align stickers (2x3 or larger) directly over support blocks

Use support blocks (6x6 or larger) at 10' on-center to keep bundles out of mud and water

LATERAL LOAD CAPACITY AND 1¼" TIMBERSTRAND® LSL RIM BOARD

Why is lateral load capacity of rim boards important?

Lateral loading on structures is typically from wind or seismic forces, and rim board is an important structural link for resisting those lateral loads. To further explain lateral loads, let's look at a typical home and how the wind loads travel through the building:

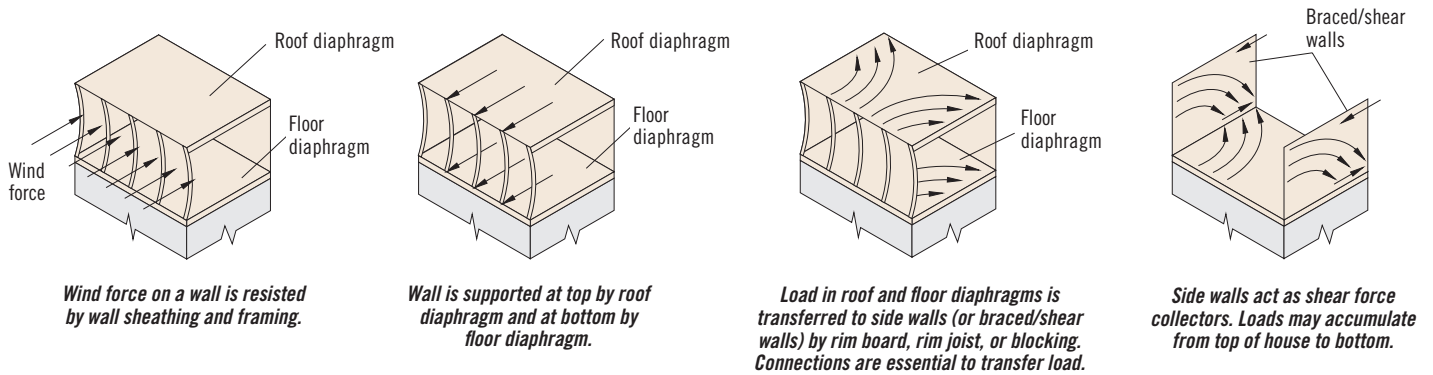

How do lateral capacities of 1¼" TimberStrand® LSL rim board compare to sawn lumber framing?

In floor or roof diaphragms, 1¼" TimberStrand® LSL rim board is capable of transferring the same lateral loads allowed by code for 2" nominal framing members. This equivalency was verified by testing: International Building Code, Case 1, unblocked diaphragm at 240 plf with 2¾" sheathing and 8d (0.131" x 2½") nails at 6" on-center.

RIM BOARD INSTALLATION DETAIL

Rim Board Installation Detail⁽¹⁾⁽²⁾⁽³⁾

Specifications	Prescriptive		Designed ⁽⁴⁾		
	A3	A3.1	A3.2	A3.3	A3.4
Minimum Rim Board Thickness	1½"	1½"	1¼"	1¼"	1¼"
Plate Nail - (0.131 x 3") ⁽⁵⁾	12" o.c. ⁽⁶⁾	12" o.c. ⁽⁶⁾	12" o.c. ⁽⁶⁾	Designed shear wall	
Floor Panel Nail - 8d common (0.131" x 2½") ⁽⁵⁾	6" o.c.	6" o.c.	6" o.c.	4" o.c. minimum	
Rim Board to TJI® Joist—(0.131" x 3")	One into each flange				
Toe Nail—(0.131" x 3")	6" o.c.	6" o.c.	6" o.c.	4" o.c.	By design professional ⁽⁷⁾
TJI® Joist to Plate—(0.113" x 2½")	Two nails driven at an angle into bottom flange, one each side of web at least 1½" from end				
Wall Framing	Per code	Per code	Per code	Designed shear wall	
Lateral Load (plf)	Per code	220 ⁽⁸⁾	240 ⁽⁸⁾	350 ⁽⁸⁾	By design professional ⁽⁷⁾

- All sheathing must be properly blocked and nailed.
- Minimum rim thickness shown allows one row of nails for shear wall and floor panel. For alternate spacing and additional rows of nails for different rim board thicknesses, see TB-206.
- Verify the lateral capacity of the wall. Not all types of code allowed wall construction provide the same lateral resistance. Check with local building officials or the design professional of record.
- Shear wall loading plus floor diaphragm loading cannot exceed lateral capacity listed unless additional connections designed.
- Nailing is based on a 2¾" thick floor panel. For thicker floor panels, nail lengths may need to be increased. Refer to IRC/IBC or design professional.
- Per code, increase nailing to 4" on center for braced walls.
- Capacity of combined toe-nail and lap sheathing connection developed by design professional.
- Lateral load capacities are for seismic design applications. No further increases for duration of load are allowed, except loads may be increased by a factor of 1.4 for wind design applications.

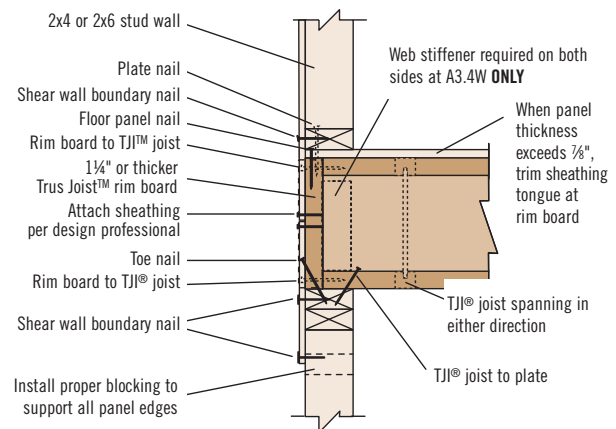
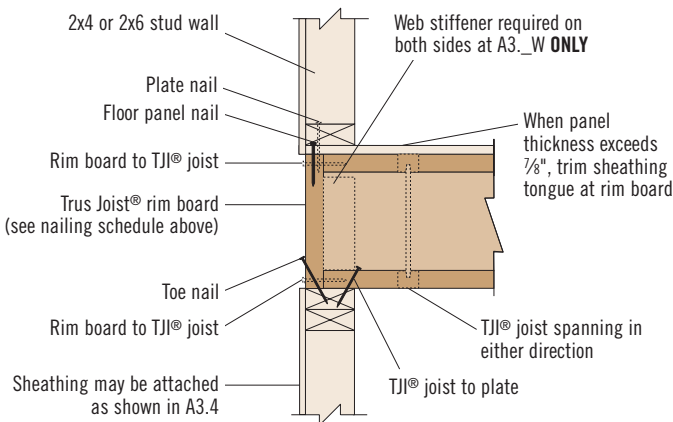

DESIGN PROPERTIES

Allowable Design Stresses⁽¹⁾ (100% Load Duration)

Product / Grade	G Shear Modulus of Elasticity (psi)	E Modulus of Elasticity (psi)	E _{min} Adjusted Modulus of Elasticity ⁽⁴⁾ (psi)	E Cross-Grain Modulus of Elasticity (psi)	F _b Flexural Stress (psi)	F _{c,L} Compression perpendicular to grain ⁽⁶⁾ (psi)	F _{c,} Compression parallel to grain (psi)	F _v Horizontal shear parallel to grain (psi)	SG Equivalent Specific Gravity ⁽⁷⁾	
									Face Grain (psi)	Edge Grain (psi)
1½" TJ® Rim Board ⁽²⁾	—	0.6 x 10 ⁶	305,000	220,000	700	710	—	425	0.32 ⁽⁸⁾	—
1.3E TimberStrand® LSL ⁽³⁾	81,250	1.3 x 10 ⁶	660,750	147,000	1,700 ⁽⁵⁾	710	1,835	425	0.50 ⁽⁹⁾	0.50 ⁽¹⁰⁾
1.55E TimberStrand® LSL	96,875	1.55 x 10 ⁶	787,815	170,000	2,325 ⁽⁵⁾	900	2,170	310	0.50 ⁽⁹⁾	0.50 ⁽¹⁰⁾

- Unless otherwise noted, adjustment to the design stresses for duration of load are permitted in accordance with the applicable code.
- 1½" TJ® Rim Board is recognized as an acceptable rim board material for use in conventional construction. It has a maximum lateral transfer capacity of 220 plf; maximum span is 8 feet.
- 1¼" TimberStrand® LSL rim board is recognized by code as providing the lateral transfer capacity equivalent to 2" nominal Douglas fir-larch or southern pine in horizontal diaphragms.
- Reference modulus of elasticity for beam stability calculations, per NDS®.
- For 12" depth. For other depths, multiply F_b by the appropriate factor as follows:
 - For TimberStrand® LSL, multiply by $\left[\frac{12}{d}\right]^{0.092}$
- F_{c,L} must not be increased for duration of load.

- For lateral connection design only.
- Specific Gravity of 0.50 may be used for nails, screws and bolts installed perpendicular to face and loaded perpendicular to grain.
- Specific Gravity of 0.58 may be used for bolts installed perpendicular to face and loaded perpendicular to grain.
- For nails and screws only.

For applications not covered in this brochure, use ForteWEB® software or contact your Weyerhaeuser representative.

NAILING ON NARROW FACE

Nails Installed on the Narrow Face

Product	Closest On-Center Spacing Per Row ⁽¹⁾			
	Nail Size			
	8d (0.113" x 2½"), 8d (0.131" x 2½"), 10d (0.128" x 3"), 12d (0.128" x 3¼"), 10d (0.148" x 3")	12d (0.148" x 3¼"), 16d (0.135" x 3½"), 16d (0.148" x 3¼")	16d (0.162" x 3½")	(0.131" x 3" - 3½")
1½" TJ® Rim Board	6"	12" ⁽²⁾	16" ⁽³⁾	12" ⁽⁴⁾
1¼" 1.3E TimberStrand® LSL	4"	4"	6" ⁽⁴⁾	4"
1½" 1.3E TimberStrand® LSL	3"	3"	6" ⁽⁴⁾	3"
1¼" and 3½" 1.55E TimberStrand® LSL	3"	3"	6" ⁽⁵⁾	3"

- To minimize splitting, maintain edge distance and row spacing of 2½ x nail diameter or ¾", whichever is greater. Multiple rows must be staggered and equally spaced from the centerline of the narrow face axis.
- Can be reduced to 5" on-center with maximum nail penetration of 1¼" into the narrow edge (for example, nails that connect the sole plate above to the block or rim).
- Can be reduced to 8" on-center with maximum nail penetration of 1¼" into the narrow edge (for example, nails that connect the sole plate above to the block or rim).
- Can be reduced to 4" on-center with maximum nail penetration of 1¼" into the narrow edge (for example, nails that connect the sole plate above to the block or rim).
- Can be reduced to 3½" on-center with maximum nail penetration of 1¼" into the narrow edge (for example, nails that connect the sole plate above to the block or rim).

ALLOWABLE HOLES

Minimum distance from end of rim:
2x diameter (D) for round holes,
3x length (L) for rectangular holes

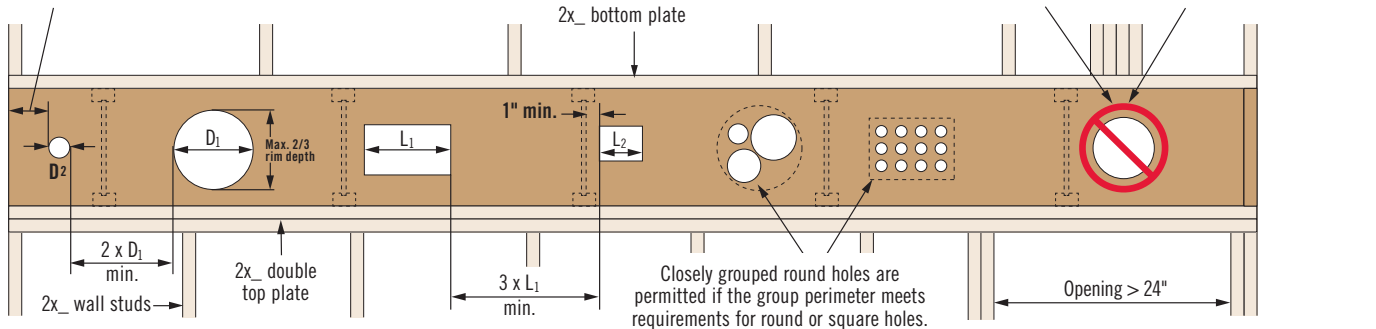

General Notes

- Permissible Hole Sizes:
 - Round hole with diameter not exceeding 2/3 rim board depth, centered vertically.
 - Square or rectangular hole with the largest dimension not exceeding 2/3 rim board depth, centered vertically.
 - 14" long rectangular hole with minimum 3½" clearance from the top edge and 2" from the bottom edge.
- The horizontal distance between the edges of adjacent round holes must be at least twice the diameter of the largest adjacent round hole, and three times the length of the largest adjacent rectangular hole.
- The horizontal distance between the end of the rim and the edge of the hole must be at least twice the diameter for a round hole and three times the hole length for a rectangular hole.
- Do not over cut rectangular holes.
- Maintain at least 1" from the edge of a floor joist.
- Do not locate holes under concentrated loads or where rim is used as a header that clear spans more than 24".

EXTERIOR DECK ATTACHMENT

Shimmed Deck Attachment

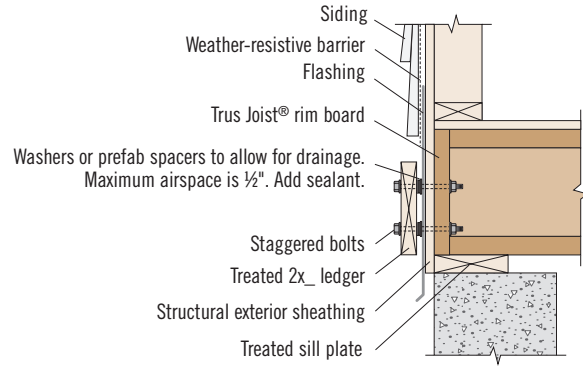
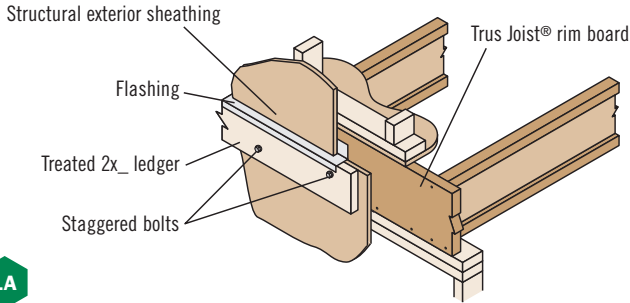

Ledger Fastener⁽¹⁾ Capacities

Product	Fastener Allowable Load ⁽²⁾ (lbs/bolt)		
	½" Lag Bolt	½" Through Bolt	½" Through Bolt with Air Space
1⅛" TJ® Rim Board	480	695	615 ⁽³⁾
1¼" 1.3E TimberStrand® LSL	610	725	
1½" 1.3E TimberStrand® LSL	675		
1¾" and 3½" 1.55E TimberStrand® LSL	725		

- (1) Corrosion-resistant fasteners required for wet-service applications.
 (2) Allowable load determined in accordance with ASTM D7672.
 (3) Maximum ½" shimmed airspace.

General Notes

- Maintain 2" distance (minimum) from edge of ledger to edge of fastener. Stagger bolts.
- Local building codes may require through bolts with washers.
- Lateral restraining connections may be required. Refer to 2021 IRC R507.9.2 and the WIJMA deck connection details.

Trus Joist® rim board products are intended for dry-use applications

HEADER APPLICATION

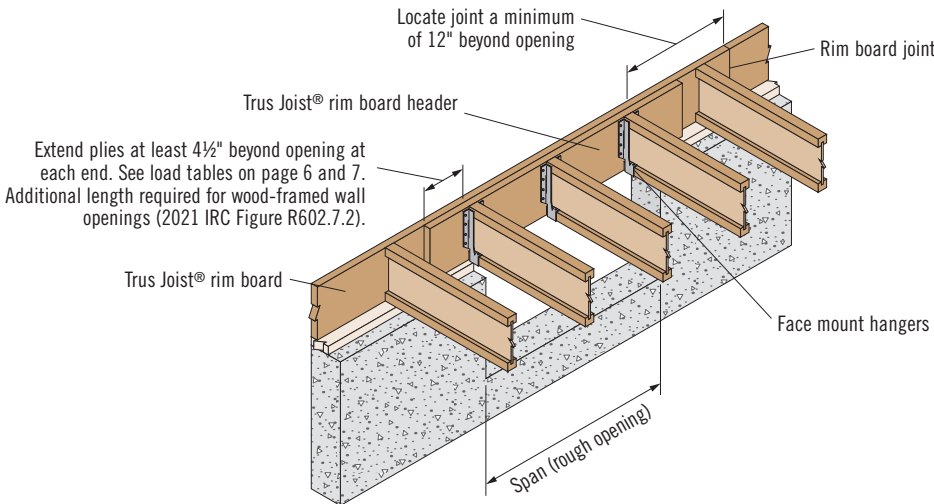

Support TJ® joists from rim board header with face mount hangers only. For 1-ply header applications, reduce hanger capacities according to hanger manufacturer's recommendations.

Clinch nails when possible.

ALLOWABLE VERTICAL LOADS

Vertical Load Transfer at Bearing⁽¹⁾

Product	Uniform Load (PLF)								Concentrated Load (lb)
	Depth								Depth
	9½"	11⅞"	14"	16"	18"	20"	22"	24"	All
1⅛" TJ® Rim Board	4,860 ⁽²⁾			NA ⁽³⁾					4,150 ⁽³⁾
1¼" 1.3E TimberStrand® LSL	5,400 ⁽²⁾		5,000	4,340	3,700	3,160	2,710	3,760	
1½" 1.3E TimberStrand® LSL	6,480 ⁽²⁾			6,380	5,740	5,070	4,440	4,520	
1¾" 1.55E TimberStrand® LSL ⁽⁴⁾	7,560 ⁽²⁾			NA					7,470

- (1) Values may not be increased for duration of load.
 (2) Capacity is limited to a maximum of 360 psi per ASTM D7672.
 (3) 1⅛" TJ® Rim Board is limited to a depth of 16" or less.
 (4) For 2-ply 1¾" or a single 3½" member, values may be doubled.

General Notes

- 1¾" and 3½" TimberStrand® LSL is beam material and may be used as rim board.

LOAD TABLES: 1-PLY RIM BOARD

Allowable Loads: 1-ply Rim Board Headers, Floor—100% (PLF)

Clear Span	Condition	1 1/8"		1 1/4" 1.3E		1 1/2" 1.3E		1 3/4" 1.55E		
		TJ® Rim Board		TimberStrand® LSL		TimberStrand® LSL		TimberStrand® LSL ⁽¹⁾		
		9 1/2"	11 7/8"	9 1/2"	11 7/8"	9 1/2"	11 7/8"	9 1/2"	11 7/8"	14"
2'-0"	Total Load	1,971	2,147	2,386	2,386	2,863	2,863	3,339	3,339	3,339
	Live Load	*	*	*	*	*	*	*	*	*
2'-6"	Total Load	1,260	1,717	1,908	1,908	2,289	2,289	2,669	2,669	2,669
	Live Load	*	*	*	*	*	*	*	*	*
3'-0"	Total Load	874	1,367	1,589	1,589	1,907	1,907	2,223	2,223	2,223
	Live Load	*	*	*	*	*	*	*	*	*
3'-6"	Total Load	641	1,003	1,361	1,361	1,634	1,634	1,904	1,904	1,904
	Live Load	*	*	*	*	*	*	*	*	*
4'-0"	Total Load	490	767	1,190	1,190	1,429	1,429	1,665	1,665	1,665
	Live Load	*	*	*	*	*	*	*	*	*
4'-6"	Total Load	387	605	1,058	1,058	1,269	1,269	1,479	1,479	1,479
	Live Load	*	*	*	*	*	*	*	*	*
5'-0"	Total Load	312	489	867	951	1,040	1,142	1,331	1,331	1,331
	Live Load	*	*	*	*	*	*	*	*	*
5'-6"	Total Load	258	404	716	864	859	1,037	1,209	1,209	1,209
	Live Load	*	*	*	*	*	*	*	*	*
6'-0"	Total Load	216	339	601	792	721	951	1,107	1,107	1,107
	Live Load	*	*	*	*	*	*	1,048	*	*
6'-6"	Total Load	184	288	511	731	614	877	981	1,022	1,022
	Live Load	*	*	510	*	612	*	851	*	*
7'-0"	Total Load	158	248	440	675	529	810	845	948	948
	Live Load	*	*	419	*	502	*	699	*	*
7'-6"	Total Load	137	215	383	588	460	705	735	884	884
	Live Load	*	*	348	*	417	*	581	*	*
8'-0"	Total Load	120	189	336	516	404	619	646	829	829
	Live Load	*	*	292	*	350	*	487	*	*
8'-6"	Total Load			297	456	357	548	571	779	779
	Live Load			247	452	296	543	412	755	*
9'-0"	Total Load			265	407	318	488	509	736	736
	Live Load			210	388	253	466	352	648	*
9'-6"	Total Load			237	364	285	437	448	696	696
	Live Load			181	335	217	403	302	560	*
10'-0"	Total Load			214	328	257	394	387	631	661
	Live Load			156	292	188	350	261	487	*
11'-0"	Total Load			176	271	211	325	294	520	600
	Live Load			119	224	143	269	199	374	588
12'-0"	Total Load			136	227	163	272	228	434	550
	Live Load			93	176	111	211	155	293	464
13'-0"	Total Load					129	231	180	345	507
	Live Load					88	168	123	234	372
14'-0"	Total Load					103	198	144	278	438
	Live Load					71	136	99	189	302
15'-0"	Total Load							117	227	366
	Live Load							81	155	249
16'-0"	Total Load							96	187	303
	Live Load							67	129	207

(1) Values may be doubled for 3 1/2" 1.55E TimberStrand® LSL.

* Indicates Total Load value controls.

How to Use This Table

1. Calculate total load (neglect header weight) on the header in pounds per linear foot (plf).
2. Select appropriate **Span** (center-to-center of bearing).
3. Scan horizontally to find the proper width and depth with a capacity that exceeds actual total load.
4. Verify that adequate bearing length exists.

General Notes

- Table is based on:
 - Uniform loads (header weight considered).
 - Simple span only.
 - Deflection of L/360 live load and L/240 total load.
 - Minimum end bearing of 4 1/2".
- Verify hanger capacities with selected rim board thicknesses. Capacity reductions may be required. Refer to hanger manufacturer for appropriate reductions.
- For loading conditions not shown, use ForteWEB® software or contact your Weyerhaeuser representative.

LOAD TABLES: 2-PLY RIM BOARD

Allowable Loads: 2-ply Rim Board Headers, Floor—100% (PLF)

Clear Span	Condition	1½" TJ® Rim Board				1¼" 1.3E TimberStrand® LSL				1½" 1.3E TimberStrand® LSL				1¾" 1.55E TimberStrand® LSL			
		9½"	11½"	14"	16"	9½"	11½"	14"	16"	9½"	11½"	14"	16"	9½"	11½"	14"	16"
3'-0"	Total Load	1,749	2,734	2,859	2,859	3,175	3,175	3,175	3,175	3,811	3,811	3,811	3,811	4,445	4,445	4,445	4,445
	Live Load	*	*	*	*	*	*	*	*	*	*	*	*	*	*	*	*
3'-6"	Total Load	1,283	2,007	2,449	2,449	2,720	2,720	2,720	2,720	3,264	3,264	3,264	3,264	3,807	3,807	3,807	3,807
	Live Load	*	*	*	*	*	*	*	*	*	*	*	*	*	*	*	*
4'-0"	Total Load	981	1,535	2,135	2,141	2,378	2,378	2,378	2,378	2,854	2,854	2,854	2,854	3,329	3,329	3,329	3,329
	Live Load	*	*	*	*	*	*	*	*	*	*	*	*	*	*	*	*
4'-6"	Total Load	774	1,211	1,685	1,902	2,113	2,113	2,113	2,113	2,536	2,536	2,536	2,536	2,957	2,957	2,957	2,957
	Live Load	*	*	*	*	*	*	*	*	*	*	*	*	*	*	*	*
5'-0"	Total Load	625	979	1,363	1,711	1,734	1,900	1,900	1,900	2,081	2,281	2,281	2,281	2,660	2,660w	2,660	2,660
	Live Load	*	*	*	*	*	*	*	*	*	*	*	*	*	*	*	*
5'-6"	Total Load	516	808	1,125	1,471	1,432	1,726	1,726	1,726	1,719	2,072	2,072	2,072	2,416	2,416	2,416	2,416
	Live Load	*	*	*	*	*	*	*	*	*	*	*	*	*	*	*	*
6'-0"	Total Load	432	678	944	1,234	1,202	1,582	1,582	1,582	1,443	1,898	1,898	1,898	2,213	2,213	2,213	2,213
	Live Load	*	*	*	*	*	*	*	*	*	*	*	*	2,097	*	*	*
6'-6"	Total Load	368	576	803	1,050	1,023	1,459	1,459	1,459	1,228	1,751	1,751	1,751	1,962	2,042	2,042	2,042
	Live Load	*	*	*	*	1,020	*	*	*	1,224	*	*	*	1,702	*	*	*
7'-0"	Total Load	316	496	691	904	881	1,351	1,354	1,354	1,058	1,621	1,625	1,625	1,691	1,895	1,895	1,895
	Live Load	*	*	*	*	838	*	*	*	1,005	*	*	*	1,399	*	*	*
7'-6"	Total Load	274	431	601	786	767	1,176	1,263	1,263	920	1,411	1,516	1,516	1,471	1,767	1,767	1,767
	Live Load	*	*	*	*	696	*	*	*	835	*	*	*	1,162	*	*	*
8'-0"	Total Load	240	378	527	690	673	1,032	1,183	1,183	808	1,239	1,420	1,420	1,292	1,655	1,655	1,655
	Live Load	*	*	*	*	584	*	*	*	700	*	*	*	974	*	*	*
8'-6"	Total Load					595	913	1,113	1,113	714	1,096	1,336	1,336	1,143	1,557	1,557	1,557
	Live Load					494	905	*	*	593	1,086	*	*	825	1,511	*	*
9'-0"	Total Load					530	814	1,050	1,050	636	977	1,261	1,261	1,018	1,470	1,470	1,470
	Live Load					421	777	*	*	506	932	*	*	704	1,297	*	*
9'-6"	Total Load					475	729	994	994	570	875	1,193	1,193	897	1,391	1,391	1,391
	Live Load					362	671	*	*	435	806	*	*	605	1,121	*	*
10'-0"	Total Load					428	657	902	944	514	789	1,082	1,133	775	1,263	1,321	1,321
	Live Load					313	584	*	*	376	700	*	*	523	974	*	*
11'-0"	Total Load					352	542	743	857	422	650	892	1,029	589	1,041	1,199	1,199
	Live Load					239	448	705	*	287	538	846	*	399	749	1,177	*
12'-0"	Total Load					272	454	623	785	327	545	748	942	456	868	1,098	1,098
	Live Load					186	352	556	*	223	422	667	*	311	587	928	*
13'-0"	Total Load					215	385	529	684	258	462	635	821	360	690	1,012	1,012
	Live Load					148	280	445	643	177	336	535	772	247	468	744	*
14'-0"	Total Load					172	331	455	589	206	397	546	706	288	556	876	938
	Live Load					119	227	362	525	143	272	435	630	199	379	605	877
15'-0"	Total Load					139	271	395	511	167	325	474	613	234	454	732	875
	Live Load					97	186	298	434	117	223	358	521	163	311	498	724
16'-0"	Total Load					114	223	346	448	137	268	415	537	192	374	606	819
	Live Load					80	154	248	362	97	185	298	435	135	258	414	605

* Indicates Total Load value controls.

See *How to Use This Table and General Notes* on page 6.

MULTIPLE-MEMBER CONNECTIONS FOR 2-PLY RIM BOARD

Fastener Installation Requirements⁽¹⁾⁽²⁾

Loading Condition	Ply Width	Fastener Requirements			On-Center Spacing	Maximum Uniform Load Applied to Either Outside Member (plf)
		Nail Type ⁽³⁾	Placement	# Rows		
Top	1½", 1¼", 1½"	8d or 10d	One face	3 ⁽⁴⁾	12"	—
	1¾"	10d		3 ⁽⁴⁾		—
Side	1½", 1¼", 1½"	8d	One face	2	12"	290
	1½", 1¼", 1½", 1¾"	10d		3		430
				3		370
				3		560

(1) For connection of two 3½"-wide plies, see Weyerhaeuser's *Trus Joist® Beam, Header and Column Specifier's Guide*, TJ-9000 (or TJ-9020 for the Pacific Coast and Northwest).

(2) Clinch nails when possible.

(3) 8d nails are 0.113" diameter by 2½" long; 10d nails are 0.128"-0.131" diameter by 3" long.

(4) An additional row of nails is required with depths of 14" or greater.

WE CAN HELP YOU BUILD SMARTER

You want to build solid and durable structures—we want to help. Weyerhaeuser provides high-quality building products and unparalleled technical and field assistance to support you and your project from start to finish.

Floors and Roofs: Start with the best framing components in the industry: our Trus Joist® TJI® joists; TimberStrand® LSL rim board; and TimberStrand® LSL, Microllam® LVL, and Parallam® PSL headers and beams. Pull them all together with our self-gapping and self-draining Weyerhaeuser Edge Gold™ floor panels and durable Weyerhaeuser roof sheathing.

Walls: Get the best value out of your framing package—use TimberStrand® LSL studs for tall walls, kitchens, and bathrooms, and our traditional, solid-sawn lumber everywhere else. Cut down installation time by using TimberStrand® LSL headers for doors and windows, and Weyerhaeuser wall sheathing with its handy two-way nail lines.

Software Solutions: Whether you are a design professional or lumber dealer, Weyerhaeuser offers an array of software packages to help you specify individual framing members, create cut lists, manage inventories—even help you design a complete structural frame. Contact your Weyerhaeuser representative to find out how to get the software you need.

Technical Support: Need technical help? Weyerhaeuser has one of the largest networks of engineers and sales representatives in the business. Call us for help, and a skilled member from our team of experts will answer your questions and work with you to develop solutions that meet all your structural framing needs.

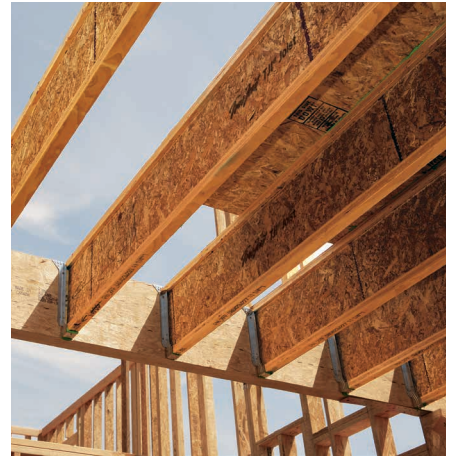

LIMITED LIFETIME PRODUCT WARRANTY

Weyerhaeuser provides limited lifetime warranties for all Trus Joist® branded products. Product information, installation instructions, and the full text of each product's limited warranty (including limitations and exclusions) are available on the Weyerhaeuser website, from your Weyerhaeuser representative, or by calling toll free: 888-453-8358.

Additionally, Weyerhaeuser offers limited warranties on a broad variety of its other products. To see complete details of all Weyerhaeuser product warranties, visit weyerhaeuser.com/woodproducts/warranty.

1.888.453.8358
WEYERHAEUSER.COM/WOODPRODUCTS

Header 11/2022 December 2024. ▲ Weyerhaeuser and Trus Joist are registered trademarks of Weyerhaeuser NR. © 2025 Weyerhaeuser NR Company. All rights reserved. Complete details for product and general information available only for wood products. Please visit weyerhaeuser.com/woodproducts.

CONTACT US

1.888.453.8358 • weyerhaeuser.com/woodproducts/contact

Contact your local representative or dealer at:

Visit weyerhaeuser.com/woodproducts/warranty for copies of this and other Trus Joist® Engineered Wood Product warranties.

March 2025 • Reorder TJ-8000

This document supersedes all previous versions. If this is more than one year old, contact your dealer or Weyerhaeuser rep.

▲ Weyerhaeuser, Microllam, Parallam, TimberStrand, TJ, TJI, and Trus Joist are registered trademarks and Edge Gold is a trademark of Weyerhaeuser NR. © 2025 Weyerhaeuser NR Company. All rights reserved. Printed in the USA.