

FIRE-RATED ASSEMBLIES AND SPRINKLER SYSTEMS

Featuring Fire Assembly Details and Sprinkler Installation Guidelines

- For Use with Trus Joist® Products Only
- Floor/Ceiling, Roof/Ceiling, and Wall Assemblies
- Fire Facts Q&A
- CPVC and Steel Sprinkler Pipe Details

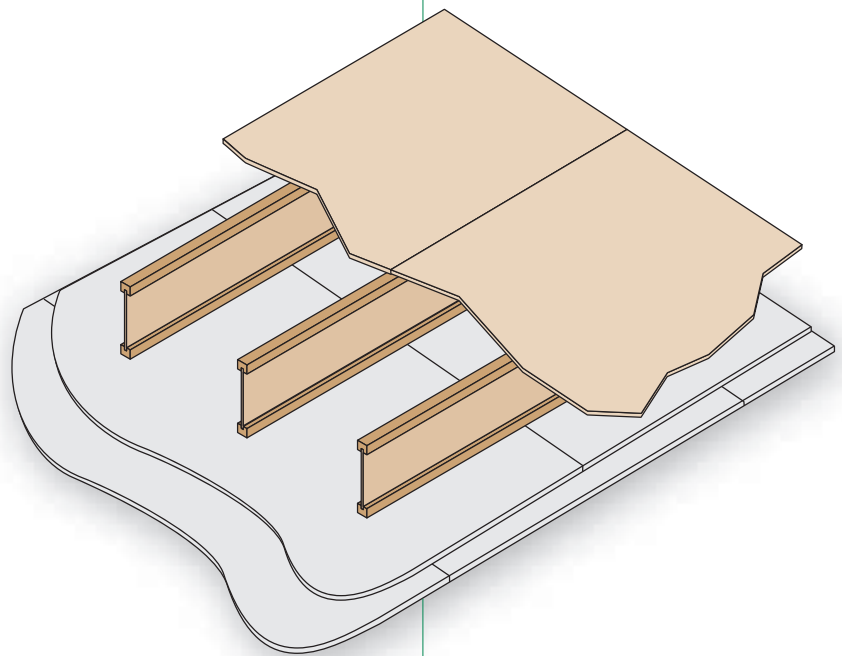



This guide contains information to help you specify and install Trus Joist® products in fire-safe assemblies in floors, roofs, and walls; and provides technical information and details for installing sprinkler systems. The information provided is intended for use with Trus Joist® products only. For applications beyond the scope of this publication, contact your Weyerhaeuser representative.

TABLE OF CONTENTS

Fire-Safe Construction	
Fire-Resistance Categories	2-3
Fire Suppression and Protection	3
Char Rates and Flame Spread	4
Floor/Ceiling, Roof/Ceiling Assemblies	5-6
45-Minute Floor/Ceiling Assemblies for Canada	7
Fire-Resistance-Rated Assemblies	
Center-Wall	8-10
End-Wall	11-12
Two-Hour Fire-Resistance-Rated End-Wall Assemblies, Type III Construction	12-14
1-Hour Wall Assembly with TimberStrand® LSL Studs	14
Fire Facts Q&A	15-16
Sprinkler Systems	
General Assumptions and Guidelines	17
TJI® Joist Descriptions	17
Fasteners	17
Allowable Holes	18
TJI® Joist Sprinkler Details	
CPVC	19-20
Steel Pipe	21-23
Seismic	24-25



Certified Sourcing

www.forests.org
SFI-00008

Fire-Safe Construction

Fire-safe construction and life safety are major concerns for everyone in the building materials and construction industry. The 2015 U.S. Fire Administration statistics⁽¹⁾ on residential and commercial fires in the U.S. alone include 3,280 fire fatalities and an estimated \$14.3 billion in property damage. These numbers underscore the seriousness of the issue and the need for fire-safe construction.

For over 40 years, prefabricated wood I-joists and other Weyerhaeuser building products have established a record of safe and reliable performance in millions of structures. Many of these structures, such as one- or two-family residential dwellings, do not require specific fire-resistance ratings per building codes but may require unrated membrane protection. The information provided in this guide is intended to help you make an informed decision on fire-safe design and specify Trus Joist® products with fire safety in mind.

Additional information on fire-resistance testing and fire-safe construction can also be found online; see the websites referenced on page 15.

Note: Some TJI® joist sizes and series may not be available in your region. Contact your Weyerhaeuser representative for more information.

FIRE-RESISTANCE CATEGORIES

There are two categories of construction: fire-resistance-rated and unrated.

Fire-resistance-rated construction requirements govern the following:

- Materials and assemblies used for structural fire resistance
- Fire-resistance-rated construction practices
- Requirements for the separation of adjacent spaces that safeguard against the spread of fire and smoke within a building and between buildings.

Unrated construction does not require a fire-resistance rating because it relies on other forms of protection, such as:

- Smaller areas of habitable space
- Multiple paths of exit, such as doors and windows
- Spacing between houses

Fire-Resistance-Rated Construction

Multi-family and commercial buildings usually require fire-resistance-rated construction and sprinklers because of the structure's square footage and height. Because single-family dwellings usually have less habitable space and a lower height, they can be built using unrated construction. However, in both cases, building codes require that the building provide occupants with sufficient means to exit the structure during a fire. The building's construction must resist the spread of a fire while also maintaining sufficient structural integrity.

In fire-resistance-rated construction, building codes specify that floor/ceiling, roof/ceiling, and wall assemblies be rated using a standard fire-resistance test. ASTM E119 or CAN/ULC-S101 standard tests were used to rate the assemblies listed in this guide. In order to maintain an assembly's fire rating, penetrations such as those for lights and vents must follow specified installation methods and meet code requirements.

(1) Per USFA's website at [usfa.fema.gov/data/statistics/](https://www.usfa.fema.gov/data/statistics/)

FIRE-RESISTANCE CATEGORIES (CONTINUED)

Unrated Construction

In unrated construction, the structural elements of one-and two-family dwellings can be made of any material permitted by the building code. Fire protection requirements for dwellings usually require a physical separation (typically Type X gypsum board) between building sections such as the garage and habitable space, and a fire-resistance rated assembly between attached dwelling units. However, construction within a dwelling unit is typically unrated.

Traditionally, exposed floor or ceiling framing (such as in an unfinished basement) has been allowed in unrated construction. But starting with the 2012 International Residential Code (IRC), an unfinished floor or ceiling framing system may require protection. The IRC requires that a ½" gypsum wall board or ⅝" wood structural panel membrane (or equivalent) must be added to the underside of any floor or ceiling system that does not meet the exceptions listed in R501.3 of the 2012 IRC or R302.13 of the 2015 and later IRC.

In unrated construction, floors, roofs, and walls can be assembled in three ways:

- 1. Unrated, unprotected assemblies:** Structural members that meet the exceptions listed in R501.3 of the 2012 IRC or R302.13 of the 2015 and later IRC are left exposed (no gypsum board attached) to the occupied space. Neither the structural members nor the assembly have a required fire-resistance rating.
- 2. Unrated, membrane-protected assemblies:** A membrane that is not rated for fire resistance (e.g., standard gypsum wallboard as required by Section R501.3 of the 2012 IRC or R302.13 of the 2015 and later IRC), encloses the structural members. Neither the structural members nor the assembly have a fire-resistance rating. Penetrations in the membrane, such as those for lighting, are not regulated.
- 3. Unrated assemblies with sprinklers:** Fires are actively suppressed through code-approved sprinkler systems. Sprinklers can be added to either unprotected or membrane-protected systems.

FIRE SUPPRESSION AND PROTECTION

The *NFPA 550 Guide to the Fire Safety Concepts Tree* states that fires can be managed by suppressing the fire (with sprinklers) or controlling the fire by construction (with membrane protection). Fire safety goals such as life safety, property protection, and continuity of building operations help determine the strategy to manage fire.

Active Fire Suppression

Automatic fire sprinkler systems are commonly required by building codes in schools, office buildings, factories, and other commercial buildings. Buildings designed with sprinkler systems are allowed larger areas and a greater height than buildings designed without sprinkler systems.

Fire service agencies such as the U.S. Fire Administration promote the use of residential sprinkler systems, citing benefits such as lower overall cost of construction for the home builder, plus a safer environment and lower insurance rates for the homeowner. Using automatic fire sprinkler systems provides the following benefits:

- Early and unsupervised suppression
- Reduced fire and smoke development
- Potentially enhanced life safety for the occupant(s)

Passive Fire Protection

Independent tests show that, when compared to protected systems, unprotected framing systems (whether combustible or non-combustible) suffer increased structural degradation when exposed to fire. All floor framing materials—sawn lumber, wood I-joists, trusses, and light-gauge steel—succumb quickly to fire if not protected. Applying a protective membrane, such as gypsum ceiling board, to all types of floor framing within the structure will provide uniform protection to the structural framing members. Passive fire protection can do the following:

- Delay fire growth involving structural elements
- Reduce the potential for damage to structural elements

Concealed Space Protection

In addition to protecting occupied space, building codes require construction techniques and materials that restrict the movement of air or flames to other areas of the building through concealed spaces. Fire-blocking and draft-stopping in strategic locations retard the advancement of a concealed-space fire while occupants safely exit the structure.

Examples of concealed-space protection include the following:

- Blocking between floor joists
- Blocking between wall studs
- Plates at top and bottom of walls
- Framing around stairwell openings
- Sealing around penetrations for wiring or ventilation

Smoke Detectors

Smoke detectors are universally recognized as the most cost-effective life-saving devices. Although smoke detectors do not provide protection to the structure or to the contents in a home, they do alert occupants to potential fire hazards and allow them time to escape. Similarly, carbon monoxide detectors can also alert occupants to faulty heating appliances or air contamination in the early stages of a fire.

Fire-Resistance-Rated Assemblies

This guide includes fire-resistance-rated assemblies using Trus Joist® engineered wood products for both horizontal and vertical separations within a structure and between adjacent structures. These assemblies address requirements for multi-story and townhouse structures, which require a continuous fire separation between dwelling units and/or between buildings. Assemblies shown include:

- Fire-resistance-rated assemblies using TJI® joists for roof/ceiling and floor/ceiling applications;
- A tested wall assembly that uses TimberStrand® LSL framing;
- Details that address the intersection of horizontal and vertical assemblies using Trus Joist® rim board products, including TimberStrand® LSL and TJI® Rim Board.

The required fire resistance at the intersection of horizontal and vertical assemblies is typically achieved by a combination of ceiling membrane protection, direct-applied protection, and the inherent resistance of the rim board or blocking—assuming that the fire originates in the occupied space. The center-wall designs shown provide the indicated fire-resistance-rating for fires originating on either side of the wall. The end-wall designs shown provide the indicated fire-resistance-rating for fires originating on the occupancy side of exterior walls and do not contain specific details for cladding on the exterior side of the studs. Some end-wall assemblies, such as those installed close to a property line or at the location of an interior stairwell, also require a fire-resistance rating from the exterior side. In those cases, protection applied to the exterior side must protect the rim board equally as well as the combination of ceiling membrane and direct-applied gypsum does on the occupancy side.

This guide does not address code requirements for firewalls that provide a complete separation and structural independence between buildings. For those applications, see NFPA 221: *Standard for High Challenge Fire Walls, Fire Walls, and Fire Barrier Walls* or an official commentary to the building code.

CHAR RATES AND FLAME SPREAD

Char Rates

Research conducted at the Forest Products Laboratory demonstrates that TimberStrand® laminated strand lumber (LSL), Parallam® parallel strand lumber (PSL), and Microllam® laminated veneer lumber (LVL) char similarly to sawn lumber. In a report dated February 2000, researcher Robert H. White concluded, “One-dimensional charring tests of structural composite lumber products, including LVLs, PSLs, and LSLs, confirmed that charring of these products in the standard fire-endurance test may be considered comparable with solid wood. Such results support the use of the fire-resistance calculation procedures for solid wood to estimate the ratings of composite lumber products.” (*Charring Rate of Composite Timber Products*, Proceedings of the 4th International Wood and Fire Safety Conference, 2000.)

In addition, Technical Report 10 (TR10) from American Wood Council (AWC) summarizes the results of fire-resistance tests of exposed structural composite lumber (SCL) beams, columns, tension members, and rim boards, which demonstrate that a nominal char rate of 1½” per hour is appropriate for the design of exposed SCL members for fire-resistance calculations. PSL, LVL, and LSL are recognized in the National Design Specification (NDS) for Wood Construction and ICC Evaluation Service Evaluation Report 1387 for fire-resistance calculations using this nominal char rate.

Flame Spread

A flame spread test is used to evaluate the surface flammability of a material or product. Test standards are defined by ASTM E84 in the United States and CAN/ULC-S102 in Canada. The Flame Spread Index is used by the model building codes to classify building content and surface finishes. A low rating means slow flame spread.

Flame Spread Comparison

Product or Wood Species	Flame Spread Index	Flame Spread Class
TimberStrand® LSL ⁽¹⁾	140	C
Parallam® PSL ⁽²⁾	50	B
Microllam® LVL ⁽³⁾	50	B
OSB ⁽⁴⁾	75–175	C
Aspen ⁽⁴⁾	105	C
Douglas Fir ⁽⁴⁾	70	B
Southern Pine ⁽⁴⁾	70	B
Hemlock (Western) ⁽⁴⁾	40	B
Ponderosa Pine ⁽⁴⁾	55	B

(1) PFS Corporation, Report No. WR-94105; aspen TimberStrand® LSL.

(2) Warnock Hersey, Fire Laboratory Division, Report No. 3521; Douglas fir Parallam® PSL.

(3) Warnock Hersey, Fire Laboratory Division, Report No. 3815; Douglas fir Microllam® LVL.

(4) Design for Code Acceptance 1, American Wood Council.

Standards for Determining Fire Resistance of Construction and Building Materials

In the United States and Canada, the model building codes rely on test standards to establish the relative fire resistance of different wall and floor or roof/ceiling assemblies. These standards include the test methods ASTM E119, ANSI/UL 263, CAN/ULC-S101, and NFPA 251. All of these tests are based on the standardized fire time-temperature curve shown below.

This time-temperature curve provides a standardized exposure for evaluating structural components and systems. This standard has been used for many decades by agencies such as ASTM, UL, and ULC, and for building codes that address fire resistance. While a tested one-hour assembly may or may not contain a real-world fire for a full hour, it does provide a relative measure of fire resistance.

With this in mind, the floor/ceiling, roof/ceiling, and wall assemblies shown on the following pages have been evaluated using this standard, and therefore can be specified for the resistance ratings stated.

Time-Temperature Curve (Used by ASTM, UL, ULC, and NFPA)

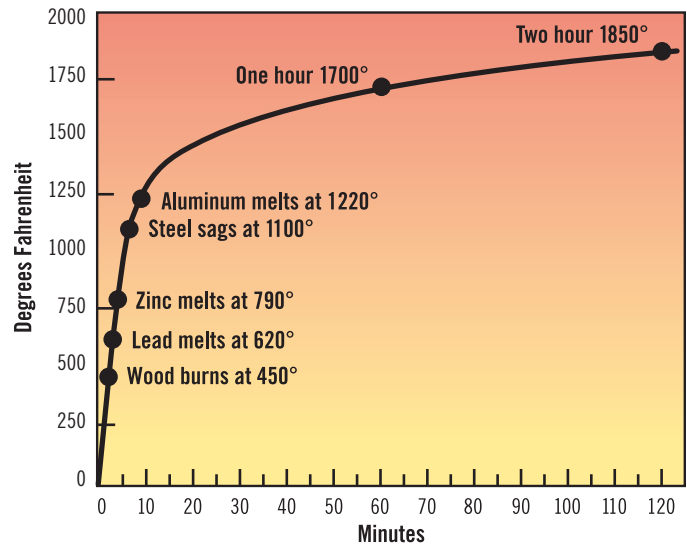

ONE-HOUR FLOOR/CEILING, ROOF/CEILING ASSEMBLIES

Lightweight concrete or approved gypsum concrete topping with appropriate sheathing can be substituted for the decking material shown in any of these assemblies.

ICC-ES
ESR-1153 Assembly A
Intertek
WNR/FCA 60-11

1. Double wood floor
2. TJI® joist with minimum 1½" flange depth (see TJI® Joist Specifications table on page 17 for flange sizes)
3. Fixture protection
4. 24" x 48" recessed light fixture
5. Cold-rolled channels
6. 12" air diffuser
7. Minimum 1"-thick (4 pcf minimum) mineral wool blankets
8. ⅝" acoustical panels, 24" x 24" or 24" x 48", supported by an approved exposed fire-rated suspension system

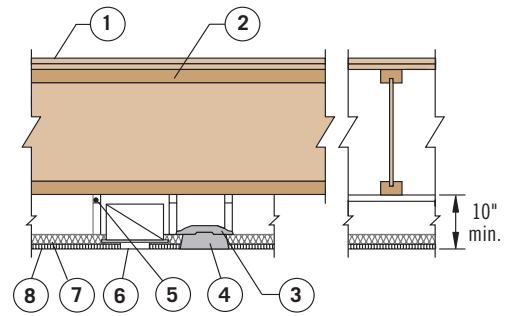

ICC-ES
ESR-1153 Assembly B
Intertek
WNR/FCA 60-01
WNR/FCA 60-03
WNR/WI 60-12

1. 48/24 tongue-and-groove, span-rated sheathing (Exposure 1), glued with a subfloor adhesive and nailed.
2. Two layers ⅝" Type X gypsum board complying with ASTM C1396 or two layers of ½" Type C gypsum board.
3. TJI® joist
4. 3½"-thick glass fiber insulation* (optional)
5. Resilient channels (required if insulation is used, optional if insulation is omitted)

*See ESR-1153 or Intertek listing for other insulation options.

Note: For information on IIC and STC ratings for Assembly B, see *Sound Performance of Trus Joist® TJI® Joist Fire Rated Floor Assemblies*, TJ-4035.

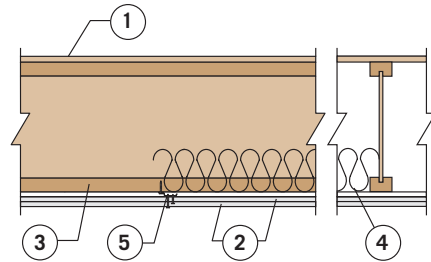

ICC-ES
ESR-1153 Assembly C

1. 48/24 tongue-and-groove, span-rated sheathing (Exposure 1), glued with a subfloor adhesive and nailed.
2. TJI® joist
3. ⅝" ceiling panels, 24" x 24"
4. Fixture protection
5. ½" Type C gypsum board or ⅝" Type X gypsum board
6. 24" x 48" recessed light fixture
7. 6" x 12" opening for return air
8. 12" diameter diffuser opening
9. Steel suspension grid

Note: Additional restrictions apply to Intertek's version of this listing. Refer to WNR/FCA 60-08 for additional information.

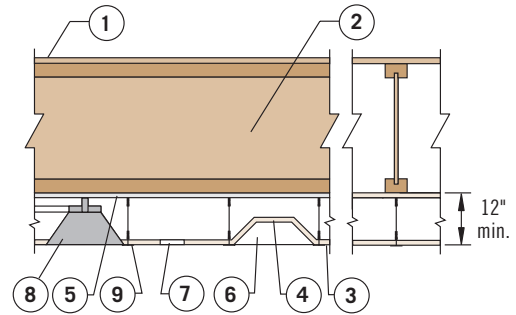

ICC-ES
ESR-1153 Assembly D
Intertek
WNR/FCA 60-05

1. 48/24 tongue-and-groove, span-rated sheathing (Exposure 1)
2. TJI® joist with minimum 1⅜" flange thickness (see TJI® Joist Specifications table on page 17 for flange sizes)
3. No. 26 gauge galvanized steel furring channel installed perpendicular to joists spaced 24" on-center. Furring channels spaced 1½" from and on each side of wallboard end joints and 24" on-center away from end joints. Channel secured to joists with support clips (item 4) at each joist location. At channel splices, adjacent pieces overlapped 6" and tied with double strand of No. 18 SWG galvanized steel wire at each end of overlap.
4. Simpson Strong-Tie Co. Type CSC support clips to be used to support furring channels at the intersection with each joist. Support clips nailed to side of joist bottom flange with 1½" long No. 11 gauge nails.
5. Stabilizer strap (not shown). ¾" x 6" No. 24 gauge galvanized-steel strap used to prevent rotation of the support clips at wallboard end joints and along walls.
6. Minimum 1"-thick (6 pcf minimum) mineral wool blankets
7. ½" Type C gypsum board for Assembly D (⅝" Type X gypsum for FCA 60-05)

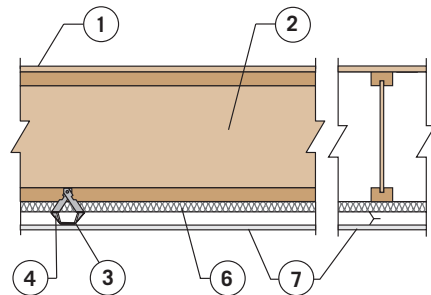

For additional construction information on these assemblies, see ICC-ES reports for the U.S. and Intertek listings for the U.S. and Canada.

ONE-HOUR FLOOR/CEILING, ROOF/CEILING ASSEMBLIES

Lightweight concrete or approved gypsum concrete topping with appropriate sheathing can be substituted for the decking material shown in any of these assemblies.

ICC-ES ESR-1153 Assembly E

1. Double wood floor or single layer of 48/24 tongue-and-groove span-rated sheathing (Exposure 1)
2. TJI® joist
3. An approved ceiling system that will provide a 40-minute finish rating

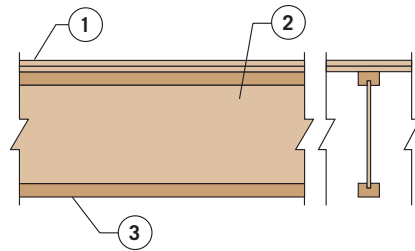

ICC-ES ESR-1153 Assembly F

Intertek WNR/WI 60-07

1. 48/24 tongue-and-groove, span-rated sheathing (Exposure 1), glued with a subfloor adhesive and nailed
2. 5/8" Type C gypsum board
3. 11 7/8" deep TJI® 560D joist minimum (minimum flange size for this assembly is 1 1/2" thick x 3 1/2" wide). Joists spaced at 24" on-center, maximum.
4. Resilient channel at 16" on-center
5. Minimum 1 1/2"-thick (2.5 pcf minimum) mineral wool batts

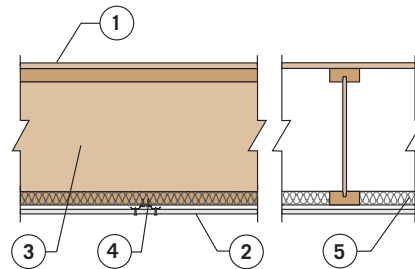

Typical detail for butt joints perpendicular to framing members

TWO-HOUR FLOOR/CEILING, ROOF/CEILING ASSEMBLY

Lightweight concrete or approved gypsum concrete topping with appropriate sheathing can be substituted for the decking material shown in any of these assemblies.

ICC-ES ESR-1153 Assembly G

Intertek WNR/WI 120-3

1. 48/24 tongue-and-groove, span-rated sheathing (Exposure 1)
2. TJI® joist, 24" on-center maximum
3. Optional glass fiber insulation, unfaced batts, 3 1/2" thick in plenum, supported by stay wires 12" on-center and centered on joist bottom flanges
4. Three layers of 5/8" Type C gypsum board
5. Resilient channels at 16" on-center located between first and second layers of gypsum board

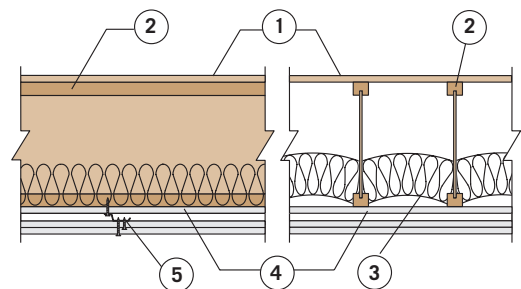

Typical resilient channel and gypsum board attachment

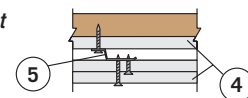

For additional construction information on these assemblies, see ICC-ES reports for the U.S. and Intertek listings for the U.S. and Canada.



45-MINUTE FLOOR/CEILING ASSEMBLIES FOR CANADA

Lightweight concrete or approved gypsum concrete topping with appropriate sheathing can be substituted for the decking material shown in any of these assemblies.

Intertek WNR/FCA 45-01

1. 48/24 tongue-and-groove, span-rated sheathing (Exposure 1)
2. TJI® joist
3. Single layer 5/8" Type X gypsum board
4. Optional resilient channels at 16" on-centre
5. If resilient channels are used, optional 3 1/2"-thick (minimum) glass fibre insulation or non-combustible insulation, rated R-30 or less, may be added.

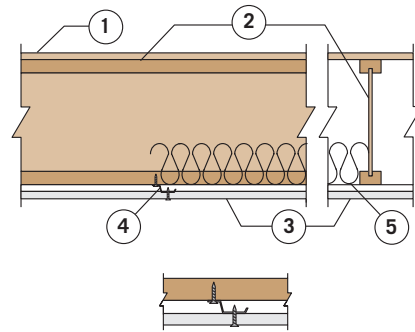

Currently, a 45-minute floor/ceiling system is only used in Canada. For additional construction information, see Intertek listings.

Note: For concrete topping applications, a single layer of 40/20 span-rated sheathing (Exposure 1) over joists at 24" on-centre with 1 1/2" lightweight concrete or 1" of gypsum concrete is an allowed deck alternative. If the joists are spaced no more than 20" on-centre, 3/4" gypsum concrete topping is permitted.

Intertek WNR/FCA 45-06

1. 48/24 tongue-and-groove, span-rated sheathing (Exposure 1). 40/20 tongue-and-groove, span-rated sheathing (Exposure 1) is permitted with proprietary gypsum as listed in WNR/FCA 45-06.
2. TJI® joist
3. Proprietary 5/8" Type C gypsum board
4. Resilient channels at 16" on-centre, maximum
5. Optional (not required): Minimum 3 1/2"-thick glass fibre insulation or non-combustible insulation, rated R-30 or less

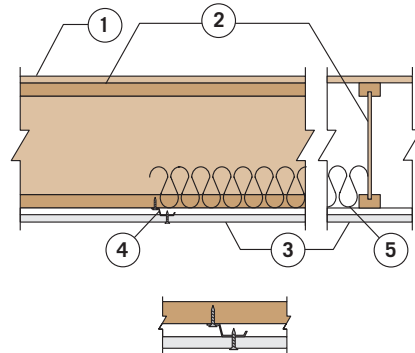

Currently, a 45-minute floor/ceiling system is only used in Canada. For additional construction information, see Intertek listings.



FIRE-RESISTANCE-RATED CENTER-WALL ASSEMBLIES

Roof Level Application Only: TJI® roof joists with non-load-bearing rim board only supporting limited roof load.

Intertek

WNR/RB 60-01

Fire-Resistance-Rating: 1 hour

1. Min. 1½"-thick TJI® Rim Board or TimberStrand® LSL.
2. Rated or unrated roof/ceiling assembly with TJI® joists running parallel or perpendicular to the wall. Ceiling membrane not required.
3. Fire-resistance-rated wall construction. Thickness of supporting wall must provide adequate bearing for TJI® joists.
4. Blocking (if required).

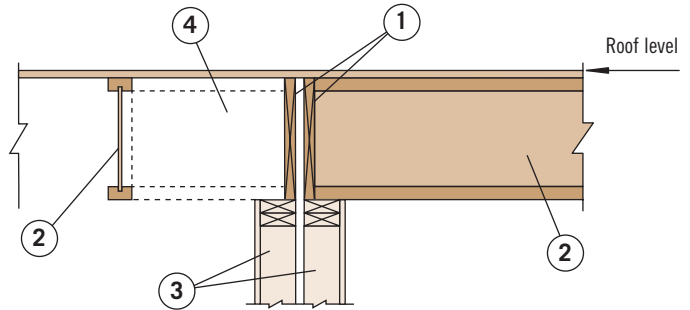

Top Floor Application: Double wall with non-load-bearing rim board only supporting limited dead load from wall above.

Intertek

WNR/RB 60-02

Fire-Resistance-Rating: 1 hour

1. Roof truss or joist, running parallel to wall.
2. Fire-resistance-rated wall construction. Thickness of supporting wall must provide adequate bearing for TJI® joists.
3. Rated or unrated floor/ceiling assembly with TJI® joists running parallel or perpendicular to the wall. Ceiling membrane not required.
4. Min. 1½"-thick TJI® Rim Board or TimberStrand® LSL.
5. Blocking (if required).

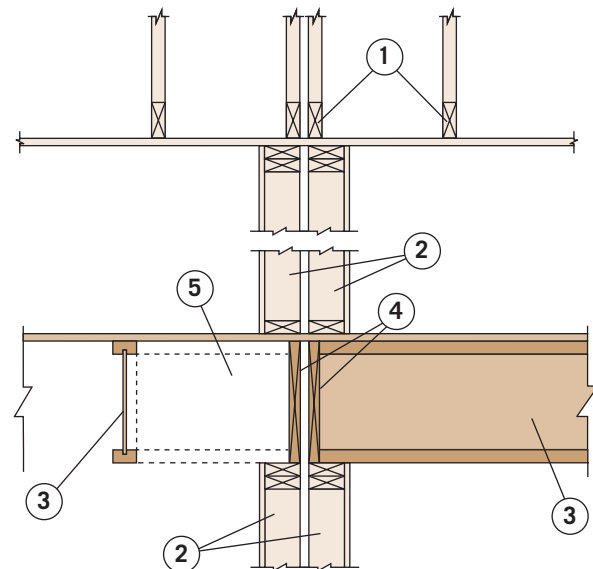

Designs above as evaluated by Intertek Testing Services. Refer to Intertek SPEC ID: 39709 at <https://bpdirectory.intertek.com>. For specific information on rim board applications, see ICC-ES ESR-1387 in the U.S. and Intertek CCRR-0222C in Canada.

FIRE-RESISTANCE-RATED CENTER-WALL ASSEMBLIES

Multi-Story Application: Double bearing wall with load-bearing rim board supporting full design load. Load applied individually to each side of the wall assembly.

Intertek

WNR/RB 60-03

Fire-Resistance-Rating: 1 hour or 45 minutes (per table)

1. Roof/ceiling or floor/ceiling assembly.
2. Fire-resistance-rated wall construction. Thickness of supporting wall must provide adequate bearing for TJI® joists.
3. Rated or unrated floor/ceiling assembly with TJI® joists running parallel or perpendicular to the wall. Ceiling membrane as required for #5 rim board protection.
4. Min. 1½"-thick TJI® Rim Board or TimberStrand® LSL.
5. Rim board protection provided by combination of ceiling membrane and direct-applied protection as detailed in table below.

Rim Board Protection

Attach rim board protection to occupancy side of rim board. Direct-applied protection may be continuous or discontinuous. Discontinuous protection must be notched at the four corners to fit tight to joist flanges and web, or the space between the I-joist web and direct-applied protection must be filled with a web stiffener (¼" gap between top flange and stiffener).

Attach first layer of gypsum with a min. of four 1½" Type W screws at a max. spacing of 12" o.c., and second layer of gypsum with a min. of four 2" Type W screws at a max. spacing of 12" o.c. Where Type X gypsum is required, Type C may be substituted.

6. Blocking (if required).

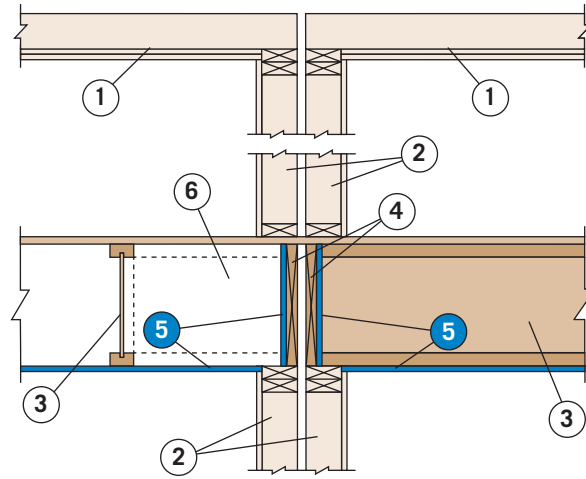

Item	Rim Board Protection (In Addition to Rim Board)		Required Ceiling Membrane		Rating (min.)
	Min. Layers	Material	Min. Layers	Material	
A	2	Min. ½" Type X gypsum	–	–	60
B	1	Min. ⅝" Type X gypsum	–	–	45, 60 ⁽¹⁾
C	1	Min. 1½" material from #4	–	–	60
D	1	Min. 1½" material from #4	1	Min. ½" Type X gypsum	60
E	1	Min. ⅝" Type X gypsum	1	Unrated ½" gypsum	60
F	1	Min. ½" Type X gypsum	1	Unrated ½" gypsum	45
G	1	Min. ½" Type X gypsum	1	Min. ½" Type X gypsum	60
H	1	Min. ½" unrated gypsum or 1½" mineral wool batt insulation friction fit in place	1	Min. ⅝" Type X gypsum	60
I	–	–	1	Min. ⅝" Type X gypsum	45
J	–	–	1-hour rated ceiling of (1) ⅝" Type C, (1) ½" Type C, or (2) ½" Type X gypsum		60

(1) 60 minutes applies only to rim board with vertical load restricted to 55% of design capacity, with the exception of 1½ in. x 16 in. TJI Rim Board which is load restricted to 50% of design capacity.

Intertek

WNR/RB 60-08

Fire-Resistance-Rating: 1 hour

1. Roof/ceiling or floor/ceiling assembly.
2. One-hour fire-resistance-rated wall construction. Thickness of supporting wall must provide adequate bearing for TJI® joists.
3. Rated or unrated floor/ceiling assembly with TJI® joists (maximum 16" depth) running parallel or perpendicular to the wall. Minimum ½" regular gypsum ceiling membrane.
4. 1¾"-thick 1.5E (minimum) TimberStrand® LSL with maximum vertical load of 2,000 plf ASD (unfactored) per rim board member.
5. For rim board exceeding 11½" depth, TJI® joist blocking placed at 4' o.c. is required at walls running parallel to floor joists.

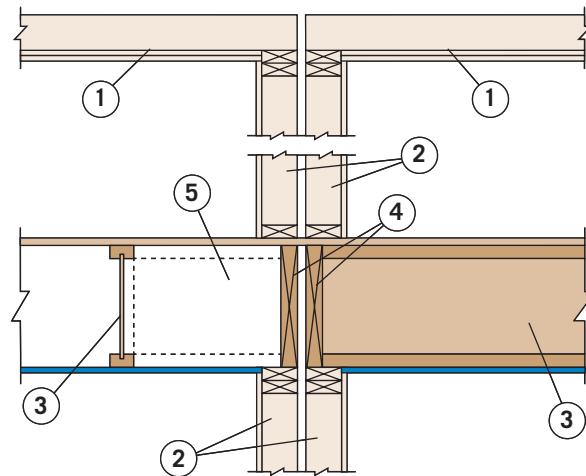

Designs above as evaluated by Intertek Testing Services. Refer to Intertek SPEC ID: 39709 at <https://bpdirectory.intertek.com>. For specific information on rim board applications, see ICC-ES ESR-1387 in the U.S. and Intertek CCRR-0222C in Canada.

Critical gypsum board placement shown in blue

FIRE-RESISTANCE-RATED CENTER-WALL ASSEMBLIES

Multi-Story Application: Single bearing wall with load bearing rim board supporting full design load.

Intertek

WNR/RB 60-04

Fire-Resistance-Rating: 1 hour or 45 minutes (per table)

1. Fire-resistance-rated wall construction. Thickness of supporting wall must provide adequate bearing for TJI® joists.
2. Rated or unrated floor/ceiling assembly with non-continuous TJI® joists running parallel or perpendicular to the wall, abutting to continuous rim board. Ceiling membrane as required for #4 rim board protection.
3. Min. 1½"-thick TJI® Rim Board or TimberStrand® LSL.
4. Rim board protection provided by combination of ceiling membrane and direct-applied protection as detailed in table below.

Rim Board Protection

Attach rim board protection to occupancy side of rim board. Direct-applied protection may be continuous or discontinuous. Discontinuous protection must be notched at the four corners to fit tight to joist flanges and web, or the space between the I-joist web and direct-applied protection must be filled with a web stiffener (1/16" gap between top flange and stiffener).

Attach gypsum with a min. of four 1½" Type W screws at a max. spacing of 12" o.c. Where Type X gypsum is required, Type C may be substituted.

5. Blocking (if required).
6. Sawn lumber joist.

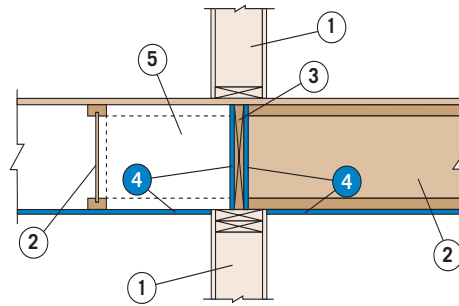

Alternate Detail

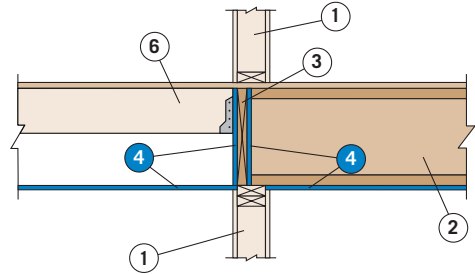

Item	Rim Board Protection (In Addition to Rim Board)		Required Ceiling Membrane		Rating (min.)
	Min. Layers	Material	Min. Layers	Material	
A	–	–	1	Min. 5/8" Type X gypsum	60
B	1	Unrated 1/2" gypsum (each side)	1	Min. 1/2" Type X gypsum	60
C	1	Min. 1 1/8" material from #3	1	Min. 1/2" Type X gypsum	60
D	–	–	1	Min. 1/2" Type X gypsum	45

Intertek

WNR/RB 60-05

Fire-Resistance-Rating: 1 hour or 45 minutes (per table)

1. Fire-resistance-rated wall construction. Thickness of supporting wall must provide adequate bearing for TJI® joists.
2. Rated or unrated floor/ceiling assembly. Continuous TJI® joists across the wall with discontinuous rim board. Ceiling membrane as required for #4 rim board protection.
3. Min. 1½"-thick TJI® Rim Board or TimberStrand® LSL.
4. Rim board protection provided by combination of ceiling membrane and direct-applied protection as detailed in table below.

Rim Board Protection

Attach rim board protection to occupancy side of rim board. Direct-applied protection may be continuous or discontinuous. Discontinuous protection must be notched at the four corners to fit tight to joist flanges and web, or the space between the I-joist web and direct-applied protection must be filled with a web stiffener (1/16" gap between top flange and stiffener).

Attach first layer of gypsum with a min. of four 1½" Type W screws at a max. spacing of 12" o.c., and second layer of gypsum with a min. of four 2" Type W screws at a max. spacing of 12" o.c. Where Type X gypsum is required, Type C may be substituted.

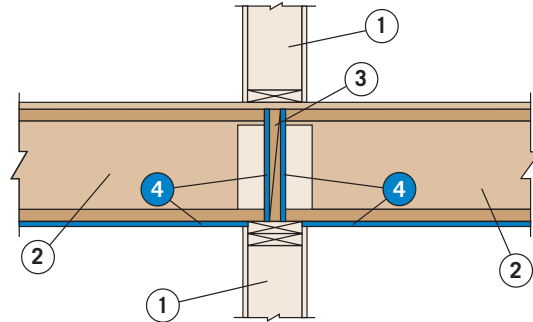

Item	Rim Board Protection (In Addition to Rim Board)		Required Ceiling Membrane		Rating (min.)
	Min. Layers	Material	Min. Layers	Material	
A	–	–	1	Min. 5/8" Type X gypsum	45
B	1	Unrated 1/2" gypsum (each side)	1	Min. 5/8" Type X gypsum	60
C	1	Min. 1 1/8" material from #3	1	Min. 1/2" Type X gypsum	60
D	1	Min. 5/8" Type X gypsum (each side)	1	Min. 1/2" Type X gypsum	60
E	2	Unrated 1/2" gypsum (each side)	1	Min. 1/2" Type X gypsum	60
F	1	Unrated 1/2" gypsum (each side)	1	Min. 1/2" Type X gypsum	45
G	–	–	1-hour-rated ceiling of (1) 5/8" Type C, (1) 1/2" Type C, or (2) 1/2" Type X gypsum		60

Designs above as evaluated by Intertek Testing Services. Refer to Intertek SPEC ID: 39709 at <https://bpdirectory.intertek.com>. For specific information on rim board applications, see ICC-ES ESR-1387 in the U.S. and Intertek CCCR-0222C in Canada.

Critical gypsum board placement shown in blue

ONE-HOUR FIRE-RESISTANCE-RATED END-WALL ASSEMBLIES

Multi-Story Application: Single bearing wall with load bearing rim board supporting full design load. *This design can also be used for interior walls or for exterior walls rated from the outside, provided that equivalent rim board protection is installed on the opposite side (not shown).*

Intertek

WNR/RB 60-06

Fire-Resistance-Rating: 1 hour or 45 minutes (occupancy side) per table

- One-hour fire-resistance-rated wall construction. Thickness of supporting wall must provide adequate bearing for TJI® joists.
- Rated or unrated floor/ceiling assembly with TJI® joists running parallel or perpendicular to the wall. Ceiling membrane as required for #4 rim board protection.
- Min. 1½" thick TJI® Rim Board or TimberStrand® LSL.
- Rim board protection provided by combination of ceiling membrane and direct-applied protection as detailed in table below.

Rim Board Protection

Attach rim board protection to occupancy side of rim board. Direct-applied protection may be continuous or discontinuous. Discontinuous protection must be notched at the four corners to fit tight to joist flanges and web, or the space between the I-joist web and direct-applied protection must be filled with a web stiffener (½" gap between top flange and stiffener).

Attach first layer of gypsum with a min. of four 1½" Type W screws at a max. spacing of 12" o.c., and second layer of gypsum with a min. of four 2" Type W screws at a max. spacing of 12" o.c. Where Type X gypsum is required, Type C may be substituted.

- Blocking (if required)

Multi-Story Application: Single bearing wall with load bearing TJI® rim joist or blocking supporting full design load. *This design can also be used for interior walls or for exterior walls rated from the outside, provided that equivalent rim board protection is installed on the opposite side (not shown).*

Joists Perpendicular to Wall

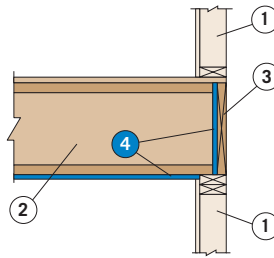

Joists Parallel to Wall

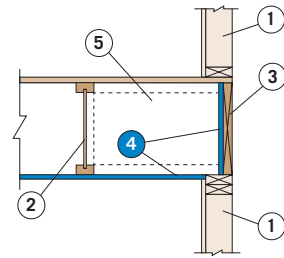

Item	Rim Board Protection (In Addition to Rim Board)		Required Ceiling Membrane		Rating (min.)
	Min. Layers	Material	Min. Layers	Material	
A	2	Min. ½" Type X gypsum	–	–	60
B	2	Min. 1½" material from #3	–	–	60
C	1	Min. 1¾" material from #3	–	–	60
D	1	Min. ½" Type X gypsum	1	Unrated ½" gypsum	60
E	2	Min. 1½" material from #3	1	Unrated ½" gypsum	60
F	1	Min. 1¾" material from #3	1	Unrated ½" gypsum	60 ⁽¹⁾
G	1	Min. ½" Type X gypsum	1	Min. ½" Type X gypsum	60
H	1	Min. 1½" material from #3	1	Min. ½" Type X gypsum	60
I	–	–	–	1-hour rated ceiling of (1) ½" Type C, (1) ½" Type C, or (2) ½" Type X gypsum	60
J ⁽²⁾	–	–	1	Unrated ½" gypsum	45
K	1	Min. 1½" material from #3	1	Unrated ½" gypsum	45
L	1	Min. ½" Type X gypsum	–	–	45
M	1	Min. 1½" material from #3	–	–	45 ⁽³⁾

- Vertical load restricted to 75% for 16" deep 1½" TJI Rim Board and 95% for 1¾" thick TimberStrand LSL.
- Vertical load restricted to 2000 plf (ASD) for 1¾" thick TimberStrand LSL up to 18" deep.
- Vertical load restricted to 45% for 1½" TJI Rim Board, 60% for 1¾" TimberStrand LSL and 80% for 1½" thick and greater TimberStrand LSL.

Intertek

WNR/RB 60-07

Fire-Resistance-Rating: 1 hour (from occupancy side)

- One-hour fire-resistance-rated wall construction. Thickness of supporting wall must provide adequate bearing for TJI® joists.
- Rated or unrated floor/ceiling assembly with TJI® joists running parallel or perpendicular to the wall. Ceiling membrane not required.

For TJI® Rim Joist:

- Continuous TJI® rim joist
- First layer:** Continuous ½" Type X gypsum board fastened to the web of the TJI® rim joist with a min. of four 1½" Type W screws at a max. spacing of 12" o.c.
Second layer: Continuous ½" Type X gypsum board, fastened to the flanges of the TJI® rim joist with a min. of four 1½" Type W screws at a max. spacing of 12" o.c.
- Blocking (if required)

For TJI® Blocking on Wall:

- TJI® blocking between joists
- First layer:** ½" Type X gypsum board extended to the web of adjacent joists fastened to the web of the TJI® blocking with a min. of four 1½" Type W screws at a max. spacing of 12" o.c.
Second layer: ½" Type X gypsum board, notched to fit at the corners and fastened to the flanges of the TJI® blocking with a min. of four 1½" Type W screws at a max. spacing of 12" o.c.

TJI® Rim Joist

Joists Perpendicular to Wall

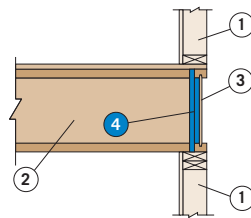

Joists Parallel to Wall

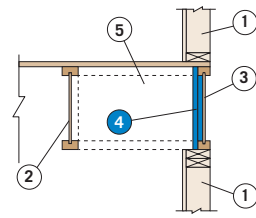

TJI® Blocking on Wall

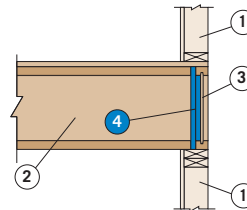

Designs above as evaluated by Intertek Testing Services. Refer to Intertek SPEC ID: 39709 at <https://bpdirectory.intertek.com>. For specific information on rim board applications, see ICC-ES ESR-1387 in the U.S. and Intertek CCCR-0222C in Canada.

Critical gypsum board placement shown in blue

TWO-HOUR FIRE-RESISTANCE-RATED END-WALL ASSEMBLIES

Multi-Story Application: Single bearing wall with load bearing rim board supporting full design load. *This design can also be used for interior walls or for exterior walls rated from the outside, provided that equivalent rim board protection is installed on the opposite side (not shown).*

Intertek

WNR/RB 120-01

Fire-Resistance-Rating: 2 hour (from occupancy side)

- Two-hour fire-resistance-rated wall construction. Thickness of supporting wall must provide adequate bearing for TJI® joists.
- Rated or unrated floor/ceiling assembly with TJI® joists running parallel or perpendicular to the wall. Ceiling membrane as required for #4 rim board protection.
- Min. 1½"-thick TJI® Rim Board or TimberStrand® LSL.
- Rim board protection provided by combination of ceiling membrane and direct-applied protection as detailed in table below.

Rim Board Protection

Attach rim board protection to occupancy side of rim board.

Direct-applied protection may be continuous or discontinuous. Discontinuous protection must be notched at the four corners to fit tight to joist flanges and web, or the space between the I-joist web and direct-applied protection must be filled with a web stiffener (¼" gap between top flange and stiffener).

Attach first layer of gypsum with a min. of four 1½" Type W screws at a max. spacing of 12" o.c., and second layer of gypsum with a min. of four 2" Type W screws at a max. spacing of 12" o.c. Where Type X gypsum is required, Type C may be substituted.

- Blocking (if required)

Joists Perpendicular to Wall

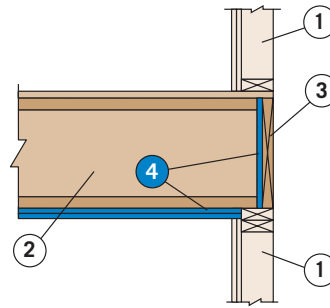

Joists Parallel to Wall

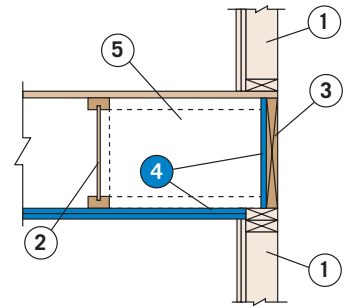

Item	Rim Board Protection (In Addition to Rim Board)		Required Ceiling Membrane	
	Min. Layers	Material	Min. Layers	Material
A	2	Min. ½" Type X gypsum	1-hour rated ceiling of (1) ⅝" Type C, (1) ½" Type C, or (2) ½" Type X gypsum	
B	2	Min. 1⅛" material from #3		
C	1	Min. 1¾" material from #3		
D	3	Min. ⅝" Type X gypsum	–	–
E	1	Min. 3" material from #3	–	–

Designs above as evaluated by Intertek Testing Services. Refer to Intertek SPEC ID: 39709 at <https://hpdirectory.intertek.com>. For specific information on rim board applications, see ICC-ES ESR-1387 in the U.S. and Intertek CCRR-0222C in Canada.

Critical gypsum board placement shown in blue

TWO-HOUR FIRE-RESISTANCE-RATED END-WALL ASSEMBLIES, TYPE III CONSTRUCTION

Multi-Story Application Type III-A Construction: Single bearing wall with load-bearing rim board. Rim board has sacrificial thickness of 1¾" to protect the remaining structural thickness in the event of fire.

Intertek

WNR/RB 120-01

AWC

DCA 3, Figure 1C

- Two-hour fire-resistance-rated exterior wall construction. Thickness of supporting wall must provide adequate bearing for TJI® joists.
- One-hour fire-resistance-rated floor/ceiling assembly with TJI® joists running parallel or perpendicular to the wall.
- 1 layer, 3½" thick TimberStrand® LSL (untreated) rim board. **Vertical load capacity is equal to the capacity of a single piece of 1¾" TimberStrand® LSL rim board in accordance with TJ-8000.**
- Fire-retardant-treated wood wall framing (studs, plates, blocking, etc.) and sheathing.
- Blocking (untreated) (as required).
- OSB or plywood (untreated).
- Exterior fire protection (as required to achieve fire-resistance rating per IBC 705.5).

Joists Perpendicular to Wall

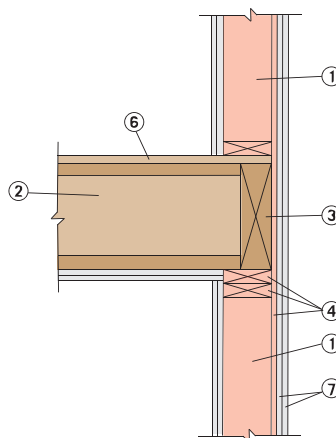

Joists Parallel to Wall

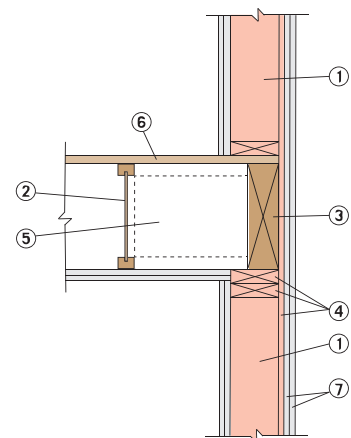

TWO-HOUR FIRE-RESISTANCE-RATED END-WALL ASSEMBLIES, TYPE III CONSTRUCTION

Multi-Story Application Type III-A Construction: Single bearing wall with load-bearing rim board and blocking. One sacrificial layer of rim board or blocking provides protection to the remaining structural layer in the event of fire.

Intertek

WNR/RB 120-01

AWC

DCA 3, Figures 1A & 1B

1. Two-hour fire-resistance-rated exterior wall construction. Thickness of supporting wall must provide adequate bearing for TJI® joists.
2. One-hour fire-resistance-rated floor/ceiling assembly with TJI® joists running parallel or perpendicular to the wall.
3. 2 layers, min. 1¾" thick TimberStrand® LSL (untreated) rim board and blocking (2 layers, min. 1¾" thick if ceiling has 2 layers of ½" Type X gypsum). **Vertical load capacity is equal to the capacity of a single piece of TimberStrand® LSL rim board or blocking in accordance with TJ-8000.**
4. Fire-retardant-treated wood wall framing (studs, plates, blocking, etc.) and sheathing.
5. Blocking (untreated) (as required).
6. OSB or plywood (untreated).
7. Exterior fire protection (as required to achieve fire-resistance rating per IBC 705.5).
8. Wood (untreated) web stiffener (maximum ¼" gap at top) or mineral wool to fill space between blocking and joist web.

Joists Perpendicular to Wall

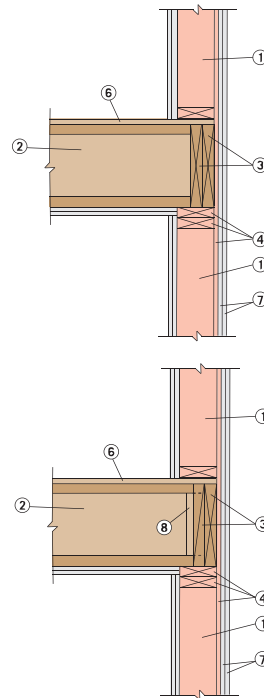

Joists Parallel to Wall

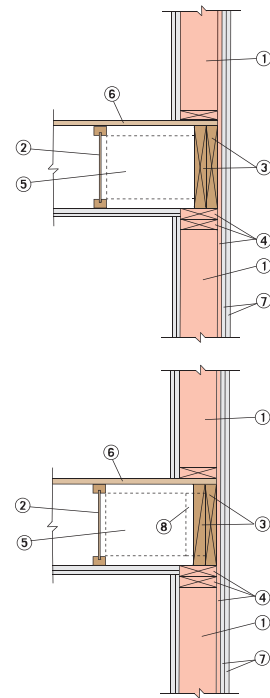

Multi-Story Application Type III-A Construction: Single bearing wall with load-bearing rim board and blocking. One sacrificial layer of rim board or blocking provides protection to the remaining structural layers in the event of fire.

Intertek

WNR/RB 120-01

AWC

DCA 3, Figures 1A & 1B

1. Two-hour fire-resistance-rated exterior wall construction. Thickness of supporting wall must provide adequate bearing for TJI® joists.
2. One-hour fire-resistance-rated floor/ceiling assembly with TJI® joists running parallel or perpendicular to the wall.
3. 3 layers, min. 1¾" thick TimberStrand® LSL (untreated) rim board and blocking (3 layers, min. 1¾" thick if ceiling has 2 layers of ½" Type X gypsum). **Vertical load capacity is equal to the capacity of two pieces of TimberStrand® LSL rim board or blocking in accordance with TJ-8000.**
4. Fire-retardant-treated wood wall framing (studs, plates, blocking, etc.) and sheathing.
5. Blocking (untreated) (as required).
6. OSB or plywood (untreated).
7. Exterior fire protection (as required to achieve fire-resistance rating per IBC 705.5).
8. Wood (untreated) web stiffener (maximum ¼" gap at top) or mineral wool to fill space between blocking and joist web.

Joists Perpendicular to Wall

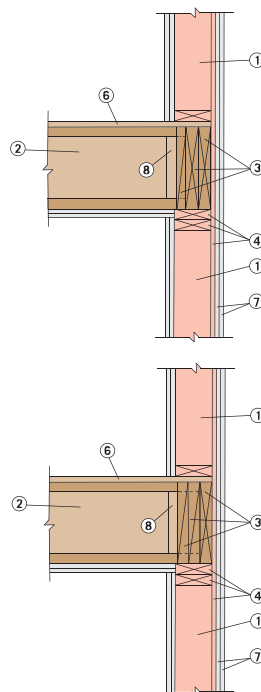

Joists Parallel to Wall

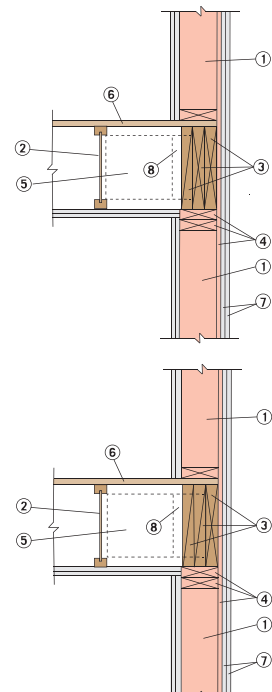

TWO-HOUR FIRE-RESISTANCE-RATED END-WALL ASSEMBLIES, TYPE III CONSTRUCTION

Multi-Story Application Type III-B Construction: Single bearing wall with load-bearing rim board and blocking. Two sacrificial layers of rim board or blocking provide protection to the remaining structural layer in the event of fire.

Intertek

WNR/RB 120-01

AWC

DCA 3, Figure 2

- Two-hour fire-resistance-rated exterior wall construction. Thickness of supporting wall must provide adequate bearing for TJI® joists.
- Unrated floor/ceiling assembly with TJI® joists running parallel or perpendicular to the wall.
- 3 layers, min. 1½" thick TimberStrand® LSL (untreated) rim board and blocking. **Vertical load capacity is equal to the capacity of a single piece of TimberStrand® LSL rim board or blocking in accordance with TJ-8000.**
- Fire-retardant-treated wood wall framing (studs, plates, blocking, etc.) and sheathing.
- Blocking (untreated) (as required).
- OSB or plywood (untreated).
- Exterior fire protection (as required to achieve fire-resistance rating per IBC 705.5).
- Wood (untreated) web stiffener (maximum ¼" gap at top) or mineral wool to fill space between blocking and joist web.

Joists Perpendicular to Wall

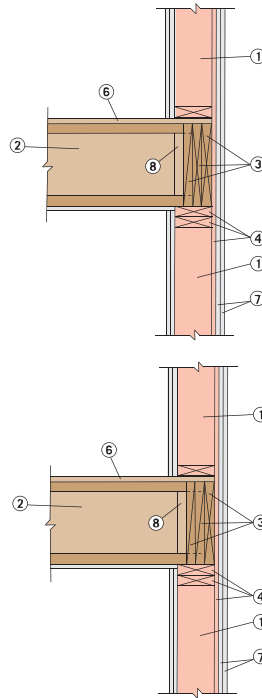

Joists Parallel to Wall

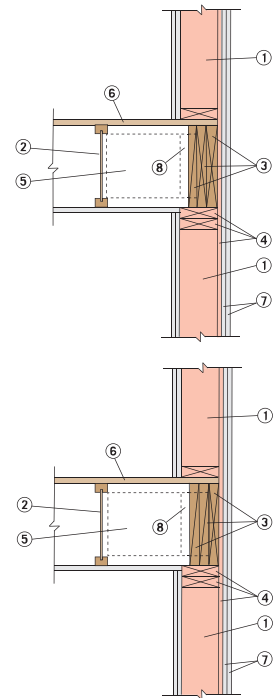

ONE-HOUR WALL ASSEMBLY WITH TIMBERSTRAND® LSL STUDS

For IBC and IRC Applications: TimberStrand® LSL of equivalent size may be substituted for sawn lumber in fire-rated assemblies, as specified in Tables 721.1(2) and 721.1(3) of the IBC. The fire resistance of protected TimberStrand® LSL assemblies may also be calculated in accordance with Chapter 3 of the ANSI/AWC *Fire Design Specification® for Wood Construction (FDS)*.

Typical TimberStrand® Wall Assemblies from the IBC

2x6 Wall - 100% Design Load

IBC Assembly 15-1.13, AWC DCA 3 Detail WS6-1.4

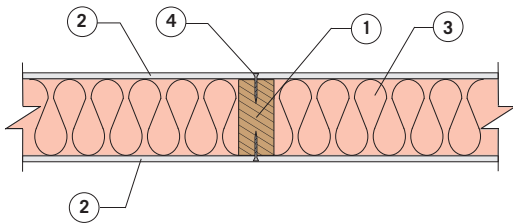

- 2x6 TimberStrand® LSL studs @ 16" on-center
- ½" Type X gypsum, 4' wide applied vertically. All panel edges backed by framing or blocking.
- R-19 fiberglass insulation
- 2¼" #6 Type S drywall screws spaced at 12" on-center

IBC Assembly 16-1.3, AWC DCA 3 Detail WS6-1.5
(Rated from gypsum wallboard side)

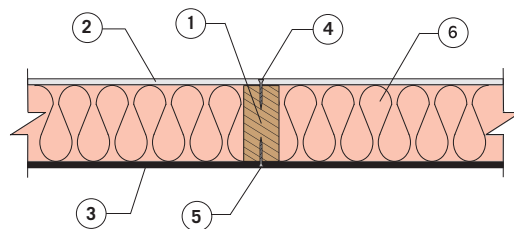

- 2x6 TimberStrand® LSL studs @ 16" on-center
- ½" Type X gypsum, 4' wide applied vertically. All panel edges backed by framing or blocking.
- ¾" OSB panel, applied vertically, horizontal joints blocked
- 2¼" #6 Type S drywall screws spaced at 7" on-center
- 6d common nails - 12" on-center field, 6" on-center panel edges
- R-19 fiberglass insulation

Wall board joists covered with tape and joint compound; fastener heads covered with joist compound.

Variations in fuel load, ventilation, and ignition source make every fire different.

FIRE-RESISTANCE RATINGS

If a fire-resistance-rated assembly has a one-hour rating, does that mean it will last one hour during a real fire?

Not necessarily. Every fire is different, so it would be virtually impossible to design a test that fits all possible scenarios. The fire-resistance rating is strictly for comparing alternative materials and assemblies against one another. The one-hour rating represents a 60-minute resistance using the standard time-temperature curve.

How realistic is the comparison between the time-temperature curve developed for standard fire-resistance tests and the conditions in a real fire?

Variations in fuel load, ventilation, and ignition source make every fire different. These disparities make it difficult to produce a time-temperature curve that reflects general fire conditions modeled for fires of similar duration and intensity.

Tests of simulated room fires conducted by the National Bureau of Standards⁽¹⁾ and the Forest Products Laboratory have produced time-temperature curves that differ noticeably from the standard curve shown on page 4. Although the standard time-temperature curve may not match any one real-world fire, it provides a widely accepted standard for evaluating the relative performance of different assemblies.

For more information on the time-temperature curve, see *Fire Development and Wall Endurance in Sandwich and Wood-Frame Structures*, by the USDA, FS, Forest Products Laboratory⁽²⁾, or *Fire Development in Residential Basement Rooms*, by the National Bureau of Standards⁽³⁾.

What is the difference between an “assembly rating” and a “finish rating”?

An assembly rating is the fire-resistance rating for an entire assembly (e.g., a one-hour assembly). A finish rating indicates how effective the ceiling or membrane is at protecting the wood structure. It represents the time it takes for the face of the framing closest to the fire to experience one of the following: a 325°F temperature rise at a single location, or an average temperature rise of 250°F over several locations. For a gypsum ceiling, it is the time required for the unexposed surface of the gypsum to reach either of these conditions. A typical finish rating for ½"-thick, fire-rated gypsum wallboard is about 20 minutes.

How does the component additive method apply to TJI® joists?

The component additive method (IBC 722.6) can be used to determine a fire-resistance rating for floor assemblies constructed with TJI® joists by assuming that TJI® joists do not contribute to the fire-resistance rating (0 minutes), and ensuring that the attached ceiling membranes provide 60 minutes of protection. For example, each layer of ½" type X gypsum wallboard is assigned 40 minutes of protection. Two layers meet the minimum required 60 minutes of protection.

Can a roof-ceiling assembly be constructed using TJI® joists without resilient channels and with more insulation than is permitted by the TJI® assemblies listed herein?

Based on the component additive method, a ceiling consisting of two layers of ½" type X gypsum wallboard will provide a one-hour fire-resistance rating, regardless of the amount of insulation and without the use of resilient channels.

Can TJI® joist assemblies in floor and roof applications maintain their fire-endurance rating when holes are cut through the web for plumbing, wiring, or duct work?

Yes. Holes of allowed sizes, drilled or cut through the joist webs to accommodate utilities, are considered when fire-resistance ratings are developed.

What are the requirements for rim board/blocking in wall separations?

Wall and roof assemblies are tested for fire endurance using ASTM E119 and CAN/ULC S101 test protocols and do not consider the role that rim board plays in wall separations. However, rim board/blocking must support its vertical design load and resist the passage of flame for a time equal to the fire-resistance-rating of the wall above. For fire exposure from the inside of the building, this can be accomplished by a combination of ceiling membrane protection, direct-applied protection, and inherent resistance of the rim board/blocking to degradation by fire. For fire exposure from the exterior of the building (where required) the fire-resistance comes from a combination of direct-applied protection and inherent resistance of the rim board/blocking to degradation by fire. Several options are presented herein for rim board/blocking supporting one- and two-hour fire-resistance-rated walls.

Does this guide include all fire-resistant assemblies evaluated for use with Weyerhaeuser products?

No. Only the most common applications are included in this guide. Additional assemblies and more information on fire testing may be found at:

American Wood Council: awc.org
(see *DCA No. 3, Fire Rated Wood Floor and Wall Assemblies*)

Gypsum Association: gypsum.org
(see *Fire Resistance Design Manual, 21st Edition GA-600-2015*)

Intertek SpecDirect: spec-direct.com
(use free access, search for Weyerhaeuser NR Company)

Underwriters Laboratories, Inc.: iq.ulprospector.com
(search for ESR-1153).

WEYERHAEUSER PRODUCTS

Can Parallam® PSL be substituted for sawn lumber or glue-laminated beams in heavy timber construction or fire-rated assemblies?

Yes. In the U.S. and Canada, Parallam® PSL is a suitable alternative in heavy timber construction

TimberStrand® LSL of the same or larger dimension may be used as a substitute for sawn lumber in fire-rated floor assemblies.

if it meets or exceeds the minimum dimensional requirements shown in Table 602.4 of the 2015 IBC (Table 2304.11 of 2018 IBC). Tests conducted at multiple accredited testing laboratories indicate that the fire resistance of Parallam® PSL is equivalent to that of sawn lumber or structural glued laminated timber.

Can TimberStrand® LSL be used as a substitute for sawn lumber in fire-resistance-rated assemblies?

TimberStrand® LSL is permitted as a substitute for sawn lumber of equal size in any fire-resistance-rated floor assembly in both the U.S. and Canada.

For fire-resistance rated wall assemblies in the U.S., TimberStrand® LSL is permitted as a substitute for sawn lumber of equal size in accordance with ICC-ES ESR1387. In Canada, work with your fire protection professional and/or the building official to determine how TimberStrand® LSL can be used on your project.

Can 1½" TJ® Rim Board and 1¼" TimberStrand® LSL be used as fire blocking?

Yes. In the U.S. and Canada, engineered lumber rim board with a minimum net thickness of 1½" may be used in lieu of 2x_ nominal lumber for fire blocking.

FLAMMABILITY

Are the flame spread ratings for Trus Joist engineered wood products similar to that of sawn lumber?

Yes. Trus Joist engineered wood products—including TJI® joists, TimberStrand® LSL, Parallam® PSL, Microllam® LVL, and TJ® Rim Board—demonstrate similar flame spread indices to sawn lumber of the same species.

What are flame spread indices and how are they used?

Flame spread indices are approximate ratings of surface flammability, which affects fire propagation rate and available escape time. Model building codes require a low flame-spread index in critical safety zones such as exit locations. Low index numbers signify slower flame spread; high numbers indicate quicker flame spread. The Flame Spread Index (FSI) ranges from 0–25 for Class A, 26–75 for Class B, and 76–200 for Class C materials.

Flame spread indices apply primarily to interior wall finishes. Because sawn lumber joists and Trus Joist® engineered wood products are used as structural supports and are typically covered with other materials, this rating is typically not an issue.

Can Weyerhaeuser engineered lumber products be treated with a fire retardant?

Weyerhaeuser does not recommend the application of fire retardants to engineered lumber products using pressure treatment or dipping. Reductions to the structural properties and impacts on dimensional stability may occur, and those reductions have not been evaluated. The application of any fire-retardant

treatment by pressure treatment or dipping voids Weyerhaeuser's product warranty. Topical, non-pressure treatments suitable for wood products can be applied subject to limitations stated in Weyerhaeuser's Technical Bulletin TB-310. However, Weyerhaeuser does not evaluate their compatibility or durability, or make any claims as to their effectiveness. Consult with the manufacturer of the fire-retardant treatment for data on the compatibility, durability and effectiveness of topical treatments.

SAFETY IN A REAL FIRE

Do the adhesives used in Weyerhaeuser engineered lumber products increase smoke toxicity compared to ordinary wood?

No. The leading cause of death in fires is smoke inhalation. Testing shows that there is no significant difference between the smoke toxicity of ordinary wood and that of engineered lumber products of the same species.

Do adhesives contribute to early structural collapse compared to the performance of ordinary wood?

No. The adhesives used in Weyerhaeuser engineered lumber products do not trigger an early structural collapse. The wood material—not the adhesive—controls fire resistance. See page 4 for flame spread and char rate information. Additional information can also be found at the American Wood Council's site: woodaware.com.

Do adhesives promote the spread of fire?

No. For strand products, such as OSB, TimberStrand® LSL, and Parallam® PSL, standardized flame spread tests show that the progression of flame along the product surface does not change within the current classification due to the presence of the adhesive. The adhesive is a small percentage of the overall product and the impact on fire spread is negligible. The adhesive used to assemble other products (such as TJI® joist flanges or Microllam® LVL) is located inside the product, away from the surface, and does not impact flame spread.

Also see the first two questions in the *Flammability* section.

Where can I find additional information on fire-resistant testing and fire-safe construction?

See the following websites for more information:

American Wood Council: awc.org

Canadian Wood Council: cwc.ca

International Code Council: iccsafe.org

International Code Council Evaluation Service: icc-es.org

National Fire Protection Association: nfpa.org

- (1) National Bureau of Standards is now known as the National Institute of Standards and Technology.
- (2) USDA, Forest Service, Forest Products Laboratory, Research Paper FPL 364, March 1980.
- (3) National Bureau of Standards, NBSIR, 80-2120, for Division of Energy, Building Technology and Standards, U.S. Department of Housing and Urban Development.

SPRINKLER SYSTEMS

This section provides information for supporting sprinkler systems with Trus Joist® TJI® joists. The technical information and details provided are intended for use with Trus Joist® products only. For options beyond the scope of this guide, contact your Weyerhaeuser representative.

General Assumptions and Guidelines

- The details in this guide are intended for use with Trus Joist® products only.
- The connections shown in the details will support the sprinkler pipes indicated or the loads shown, provided that the required loads have been included in the original design of the Trus Joist® TJI® joist system.
- The steel pipe hangers and installation methods shown in this guide are in accordance with the following design specifications:
 - NFPA 13 requires that hangers be designed to support 5 times the weight of the water-filled pipe plus 250 lbs at each point of piping support. Standard ferrous hardware referred to in NFPA 13 (such as U-hooks, eye rods, and steel trapezes) or accepted proprietary hardware are the responsibility of others.
 - NFPA 13 requires that sprinkler piping be substantially supported from the building structure, which must support the added load of the water-filled pipe plus a minimum of 250 lbs applied at the point of hanging. Fasteners (such as lag screws and machine bolts) and structural wood hanger blocks are designed to support the weight of the water-filled pipe plus a temporary 250 lb load using values from the NDS®.
- Lead holes and size limitations for fasteners are to be in accordance with the fastener information below and the applicable requirements of NFPA 13/13R.
- All wood hanger blocks are to be minimum No. 2 grade or equivalent.
- For allowable holes in the webs of TJI® joists, see tables on page 18. Tables assume uniformly loaded joists; for other loading conditions and hole sizes, contact your Weyerhaeuser representative.
- The seismic bracing shown on sprinkler details S50–S53 (on pages 24 and 25) require that the system designer specify the frequency of the bracing.
- Pipe sizes shown in steel pipe details assume pipes are supported at 15' on-center. Pipe sizes shown on CPVC details assume pipes are supported at the spacing shown in CPVC table below. Refer to NFPA for actual spacing limitations.

Assumed Loads for Water-Filled Steel Pipes at 15' on-center

Pipe Diameter	2"	2½"	3"	3½"	4"	5"	6"
Load (lbs)	77	118	162	202	246	352	475

Assumed Loads for CPVC Water-Filled Pipes

Pipe Diameter	1"	2"	3"
Load (lbs)	5	18	50
Support on-center spacing	6'	8'	10'

TJI® JOIST DESCRIPTIONS

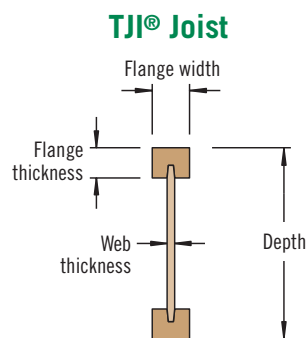

The Trus Joist® TJI® joist product line is manufactured in lengths up to 64' and in numerous depths.

Depths:
9½", 11⅞", 14", 16", 18", 20", 22", and 24"

Flange Material:
Microllam® LVL sizes shown in table at right.

Web Material:
⅜" or ½" Performance Plus® web material

TJI® Joist Specifications

TJI® Joist Series	Flange Width	Flange Thickness	Web Thickness	Depths
110	1¾"	1¼"–1⅜"	⅜"	9½", 11⅞", 14", 16"
210	2¼"	1¼"–1⅜"	⅜"	9½", 11⅞", 14", 16"
230	2⅝"	1¼"–1⅜"	⅜"	9½", 11⅞", 14", 16"
360	2⅝"	1⅜"–1½"	⅜"	9½", 11⅞", 14", 16", 18", 20"
560	3½"	1⅜"–1½"	⅞"	9½", 11⅞", 14", 16", 18", 20"
560D	3½"	1½"	⅞"	11⅞", 14", 16", 18", 20", 22", 24"

- For load capacities, bearing details, and other information, contact your Weyerhaeuser representative.

Code Evaluation: See ICC-ES ESR-1153

FASTENERS

General Guidelines for Lead Holes

Fastener Type	Approximate Lead Hole Size	Fastener Size
Nails	75% of nail diameter	0.162" diameter and larger
Wood Screws	70% of root diameter (⅛" for 18 gauge)	Larger than No. 8
Machine Bolts	Bolt diameter + ⅓₂" to ⅓₁₆" max.	All
Lag Screws	⅓₈" (1) ⅓₄" (1) ⅓₂" (1) ⅓₁₆" (1) ⅓₄" (1)	¼" diameter ⅓₁₆" diameter ⅓₈" diameter ½" diameter

(1) Lead-hole size applies to the threaded part of the lag screw. For the unthreaded length of the screw, the lead hole is equal to the shank diameter.

General Notes

- Drive screws (those driven in with a hammer) are not allowed in TJI® joists.
- Lag screws shall be installed in prebored lead holes using a wrench or a drill/driver. Do not drive lag screws with a hammer.
- Follow the tables on this page for proper choice and installation of fasteners.
- For holes in TJI® joist webs, refer to **Allowable Holes** on page 18.

Cutting or drilling oversized holes in the webs or flanges of TJI® joists can weaken the structural integrity of the member to the point where it will need to be repaired or replaced, sometimes at great expense. Proper installation of the allowed fasteners is equally important to the structural integrity of the TJI® joists.

The table below shows the largest lead-hole and fastener sizes allowed in TJI® joist flanges. All holes and attachments made to the underside of a flange shall be located per details S21 and S22 on page 21.

Maximum Lead-Hole and Fastener Sizes for TJI® Joist Flanges

Flange Location	Maximum Lead Hole Size ⁽¹⁾	Maximum Fastener Size
Side	Not allowed	10d (0.148" x 3") nail
Top or Bottom	⅓₁₆"	¼" lag ⁽²⁾⁽³⁾

- Only one hole may be drilled in any cross section of any flange.
- Requires prebored lead hole—see **General Guidelines for Lead Holes** at left.
- ⅓₈" lag allowed when joist flange width is greater than 1¾".

ALLOWABLE HOLES

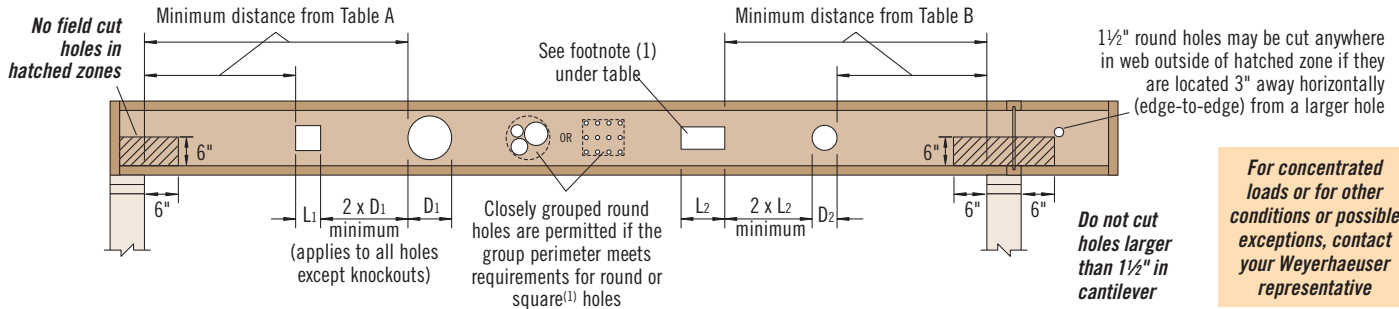
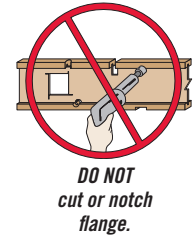

Table A—End Support

Depth	TJI®	Minimum distance from edge of hole to inside face of nearest end support					
		● Round Hole Sizes Only ⁽¹⁾					
		2"	3"	4"	5"	6"	7"
9 1/2"	110	1'-0"	1'-6"	2'-0"	3'-0"	4'-0"	
	210	1'-0"	1'-6"	2'-6"	3'-0"	4'-6"	
	230	1'-6"	2'-0"	2'-6"	3'-6"	5'-0"	
	360	1'-6"	2'-0"	3'-0"	4'-0"	5'-0"	
	560	1'-6"	2'-6"	3'-6"	5'-0"	6'-0"	
11 1/8"	110	1'-0"	1'-0"	1'-6"	2'-0"	2'-6"	3'-0"
	210	1'-0"	1'-6"	2'-0"	2'-6"	3'-0"	3'-6"
	230	1'-0"	1'-6"	2'-0"	2'-6"	3'-0"	3'-6"
	360	1'-6"	2'-0"	3'-0"	3'-6"	4'-0"	5'-0"
	560	1'-6"	2'-6"	3'-0"	4'-0"	5'-0"	6'-0"
14"	110	1'-0"	1'-0"	1'-0"	1'-0"	1'-6"	2'-0"
	210	1'-0"	1'-0"	1'-0"	1'-6"	2'-0"	2'-6"
	230	1'-0"	1'-0"	1'-0"	1'-6"	2'-0"	2'-6"
	360	1'-0"	1'-0"	1'-6"	2'-6"	3'-0"	4'-0"
	560	1'-0"	1'-0"	2'-0"	3'-0"	4'-0"	5'-0"
16"	110	1'-0"	1'-0"	1'-0"	1'-0"	1'-0"	1'-0"
	210	1'-0"	1'-0"	1'-0"	1'-0"	1'-0"	1'-6"
	230	1'-0"	1'-0"	1'-0"	1'-0"	1'-0"	1'-6"
	360	1'-0"	1'-0"	1'-0"	1'-0"	2'-0"	2'-6"
	560	1'-0"	1'-0"	1'-0"	1'-0"	2'-0"	3'-0"
18"	360	1'-0"	1'-0"	1'-0"	1'-0"	1'-0"	1'-0"
	560	1'-0"	1'-0"	1'-0"	1'-0"	1'-0"	1'-0"
	560D	1'-0"	1'-0"	1'-0"	1'-0"	1'-6"	2'-6"
20"	360	1'-0"	1'-0"	1'-0"	1'-0"	1'-0"	1'-0"
	560	1'-0"	1'-0"	1'-0"	1'-0"	1'-0"	1'-0"
	560D	1'-0"	1'-0"	1'-0"	1'-0"	1'-0"	1'-6"
22"	560D	1'-0"	1'-0"	1'-0"	1'-0"	1'-0"	1'-0"
	560D	1'-0"	1'-0"	1'-0"	1'-0"	1'-0"	1'-6"
24"	560D	1'-0"	1'-0"	1'-0"	1'-0"	1'-0"	1'-6"
	560D	1'-0"	1'-0"	1'-0"	1'-0"	1'-0"	1'-6"

Table B—Intermediate or Cantilever Support

Depth	TJI®	Minimum distance from edge of hole to inside face of nearest intermediate or cantilever support					
		● Round Hole Sizes Only ⁽¹⁾					
		2"	3"	4"	5"	6"	7"
9 1/2"	110	2'-0"	2'-6"	3'-6"	4'-6"	6'-6"	
	210	2'-0"	2'-6"	3'-6"	5'-0"	7'-0"	
	230	2'-6"	3'-0"	4'-0"	5'-6"	7'-6"	
	360	3'-0"	4'-0"	5'-6"	6'-6"	8'-0"	
	560	3'-6"	5'-0"	6'-0"	7'-6"	9'-0"	
11 1/8"	110	1'-0"	1'-0"	1'-6"	2'-6"	3'-6"	4'-6"
	210	1'-0"	1'-0"	2'-0"	3'-0"	4'-0"	5'-0"
	230	1'-0"	2'-0"	2'-6"	3'-6"	4'-6"	5'-6"
	360	2'-0"	3'-0"	4'-0"	5'-6"	6'-6"	7'-6"
	560	1'-6"	3'-0"	4'-6"	5'-6"	7'-0"	8'-6"
14"	110	1'-0"	1'-0"	1'-0"	1'-0"	1'-6"	2'-6"
	210	1'-0"	1'-0"	1'-0"	1'-0"	2'-0"	3'-0"
	230	1'-0"	1'-0"	1'-0"	2'-0"	3'-0"	4'-0"
	360	1'-0"	1'-0"	2'-0"	3'-6"	5'-0"	6'-0"
	560	1'-0"	1'-0"	1'-6"	3'-6"	5'-0"	6'-6"
16"	110	1'-0"	1'-0"	1'-0"	1'-0"	1'-0"	1'-0"
	210	1'-0"	1'-0"	1'-0"	1'-0"	1'-0"	1'-0"
	230	1'-0"	1'-0"	1'-0"	1'-0"	1'-0"	2'-0"
	360	1'-0"	1'-0"	1'-0"	1'-0"	2'-6"	4'-0"
	560	1'-0"	1'-0"	1'-0"	1'-0"	2'-0"	3'-6"
18"	360	1'-0"	1'-0"	1'-0"	1'-0"	1'-0"	1'-6"
	560	1'-0"	1'-0"	1'-0"	1'-0"	1'-0"	1'-0"
	560D	1'-0"	1'-0"	1'-0"	1'-0"	1'-0"	2'-6"
20"	360	1'-0"	1'-0"	1'-0"	1'-0"	1'-0"	1'-0"
	560	1'-0"	1'-0"	1'-0"	1'-0"	1'-0"	1'-0"
	560D	1'-0"	1'-0"	1'-0"	1'-0"	1'-0"	1'-0"
22"	560D	1'-0"	1'-0"	1'-0"	1'-6"	2'-6"	3'-6"
	560D	1'-0"	1'-0"	1'-0"	1'-6"	3'-0"	4'-0"
24"	560D	1'-0"	1'-6"	2'-6"	3'-0"	4'-0"	5'-0"
	560D	1'-0"	1'-6"	2'-6"	3'-0"	4'-0"	5'-0"



WARNING: This product can expose you to chemicals including wood dust which are known to the State of California to cause cancer, and methanol, which are known to the State of California to cause birth defects or other reproductive harm. Drilling, sawing, sanding or machining wood products can expose you to wood dust. Avoid inhaling wood dust or use a dust mask or other safeguards for personal protection. For more information go to www.P65Warnings.ca.gov and www.P65Warnings.ca.gov/wood.

Safety data sheets for all Weyerhaeuser wood products can be found on our website at: weyerhaeuser.com/woodproducts/building-green-with-wood/product-stewardship-safety-data-sheets/.

(1) Table applies to round holes only. For information on square or rectangular hole sizes, refer to the Weyerhaeuser specifier's guides listed below.

General Notes

- For simple span (5' minimum) uniformly loaded joists that meet the requirements of the Weyerhaeuser TJI® Joist specifier's guides listed at right, one maximum size round hole may be located at the center of the joist span **provided that no other holes occur in the joist**.
- Distances are based on the maximum uniform loads shown in Weyerhaeuser's TJI® Joist specifier's guides listed at right. For other loading conditions, use ForteWEB® software or contact your Weyerhaeuser representative.
- Holes may be located vertically anywhere within the web. Leave 1/8" of web (minimum) at top and bottom of hole.
- Knockouts are located in web at approximately 12" on-center; they do not affect hole placement.
- For additional hole sizes, including those for square holes, see Weyerhaeuser's TJI® Joist specifier's guides (TJ-4000 and TJ-4500).

TJI® JOIST SPRINKLER DETAILS (CPVC PIPE)

S1 Surface Mount Hanger with Double Fastener

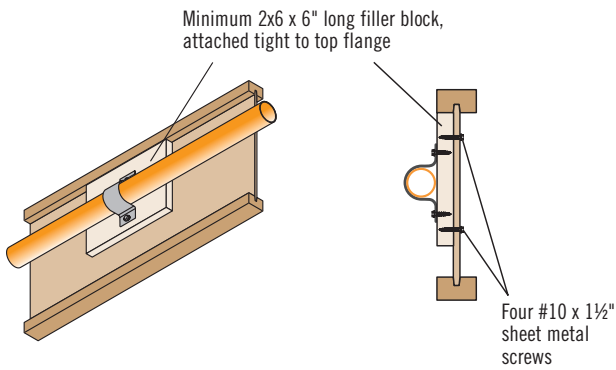

Filler Block Material	Maximum Pipe Diameter
DF or SPF	2"

Install per NFPA 13 and manufacturer's instructions.

S1A Surface Mount Hanger with Proprietary Backer Nuts

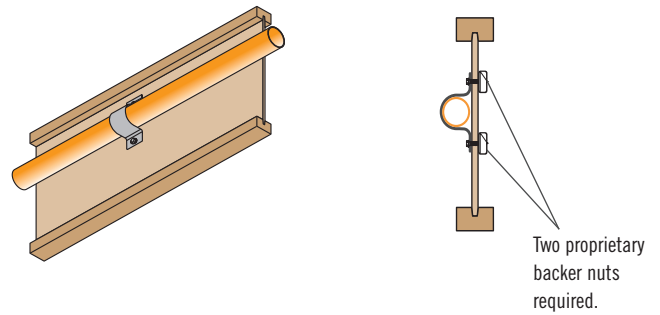

Maximum pipe diameter is 3". Install per NFPA 13 and manufacturer's instructions.

S2 Surface Mount Hanger with Single Fastener

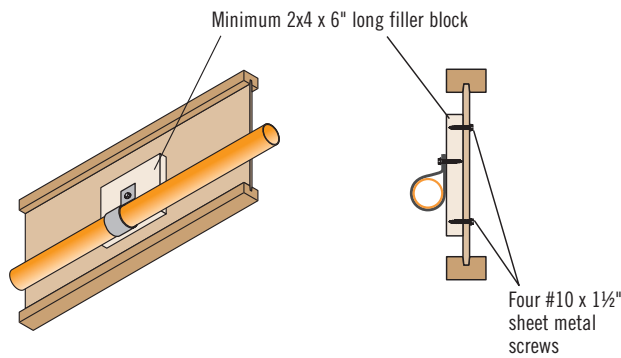

Filler Block Material	Maximum Pipe Diameter
DF or SPF	2"

Install per NFPA 13 and manufacturer's instructions.

S3 Offset Hanger

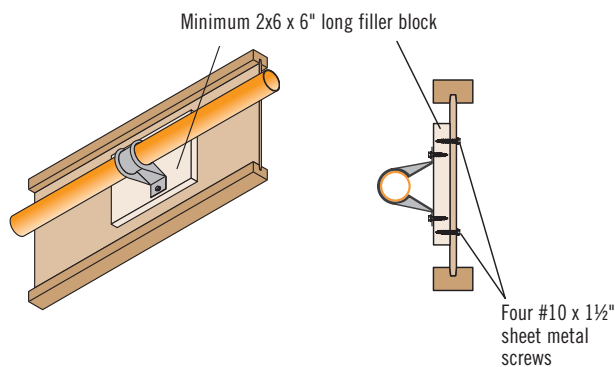

Filler Block Material	Maximum Pipe Diameter
DF or SPF	1¼"

Install per NFPA 13 and manufacturer's instructions.

S3A Offset Hanger with Proprietary Backer Nuts

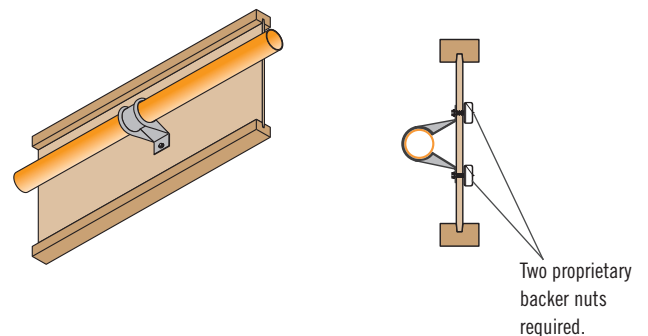

Maximum pipe diameter is 3". Install per NFPA 13 and manufacturer's instructions.

TJI® JOIST SPRINKLER DETAILS (CPVC PIPE)

S4 Double Offset Hanger

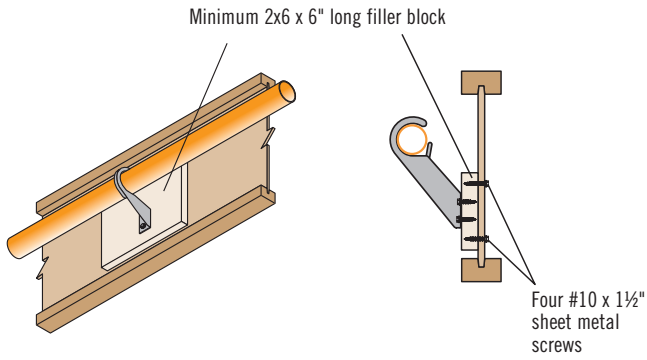

Filler Block Material	Maximum Pipe Diameter
DF or SPF	1"

Install per NFPA 13 and manufacturer's instructions.

S5 Face Mount Hanger

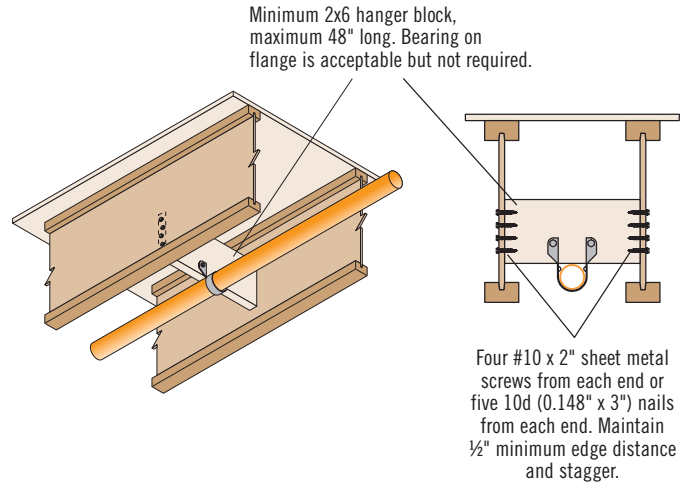

Filler Block Material	Maximum Pipe Diameter
DF or SPF	2"

Install per NFPA 13 and manufacturer's instructions.

S6 Hanger at Web Hole

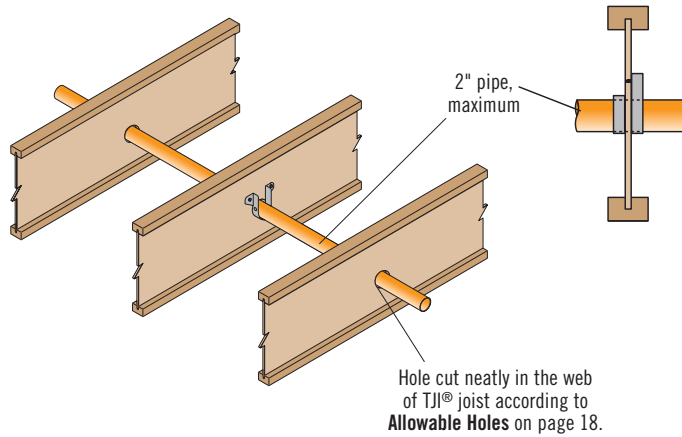

Maximum pipe diameter is 2". Install per NFPA 13 and manufacturer's instructions.

TJI® JOIST SPRINKLER DETAILS (STEEL PIPE)

S20 Beam Clamp

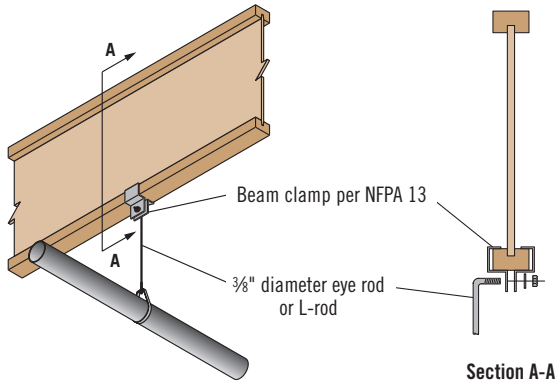

At maximum hanger spacing, maximum pipe diameter is 4". Check flange and clamp dimensions for compatibility.

S21 Ceiling Flange

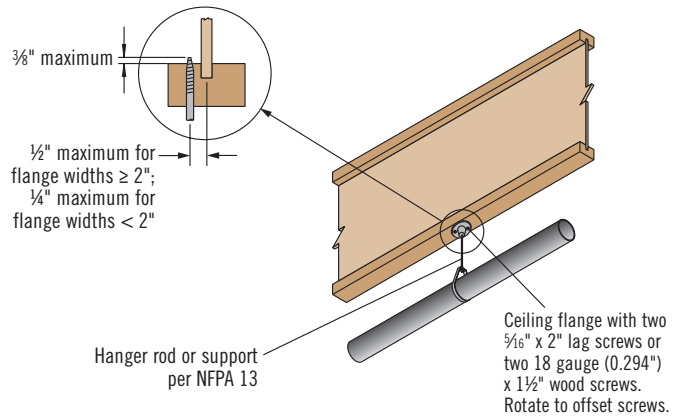

At maximum hanger spacing, maximum pipe diameter is 2". Penetration of screws into web is allowed.

S22 S22A Coach Screw into Joist Flange

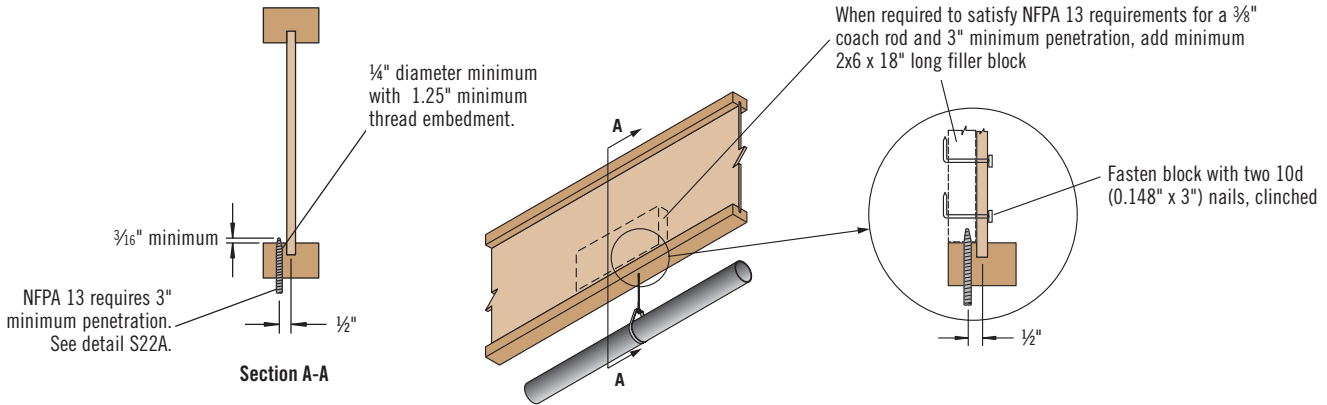

At maximum hanger spacing, maximum pipe diameter is 2". See joist flange width limitations and lead holes for fastener size on page 17.

S23 Rod Bolted to Filler Block

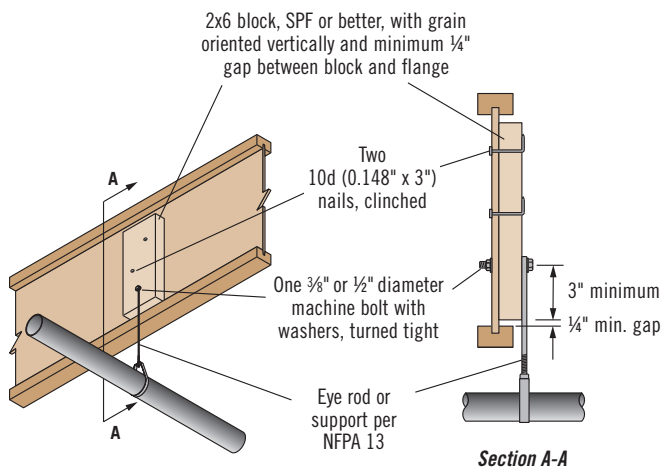

At maximum hanger spacing, maximum pipe diameter is 2" for 3/8 inch bolts, 4" for 1/2 inch bolts.

S24 Rod with Support Member

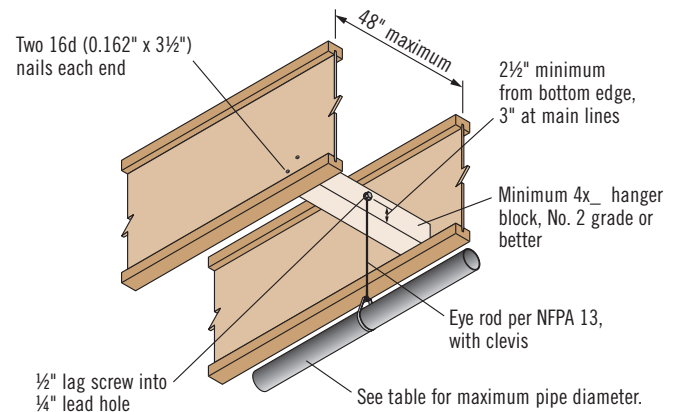

Block Material	Lag Screw Size	Maximum Pipe Diameter
DF or SP	1/2" x 3"	3 1/2"
SPF or HF	1/2" x 3"	2 1/2"

Center pipe support (parallel or perpendicular) between joists.

TJI® JOIST SPRINKLER DETAILS (STEEL PIPE)

S25 Rod with Support Member and Filler Block

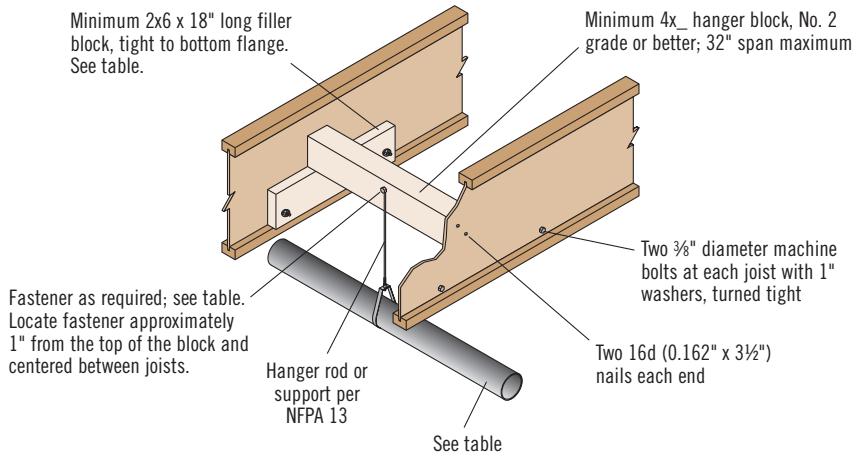

Filler Block Material	Fastener Type	Maximum Pipe Diameter
DF or SP	1/2" x 3" lag screw	3 1/2"
	3/8" machine bolt	2"
	1/2" machine bolt	6"
SPF or HF	1/2" x 3" lag screw	2 1/2"
	3/8" machine bolt	2"
	1/2" machine bolt	5"

Center pipe support (parallel or perpendicular) between joists.

S26 Rod with Side-Beam Bracket

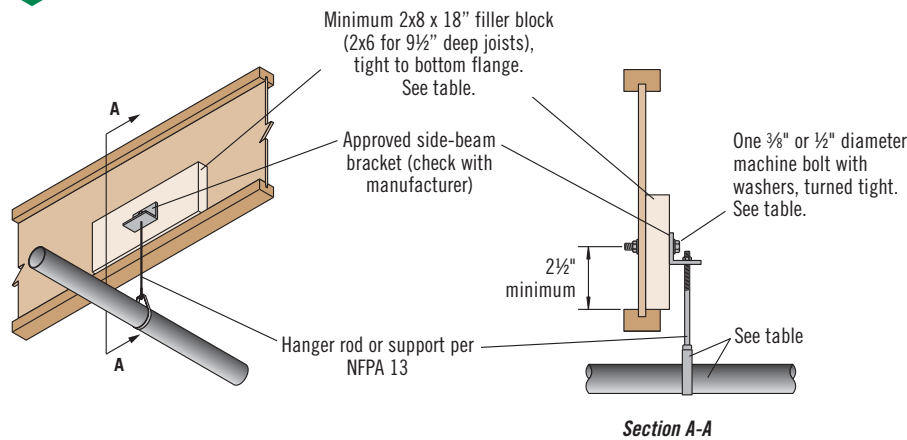

Block Material	Bolt Size	Hanger Thickness	Maximum Pipe Diameter
DF or SP	1/2"	3/8"	3 1/2"
	3/8"	3/16"	2"
SPF or HF	1/2"	3/8"	2 1/2"

S27 Rod with Steel Angle Trapeze

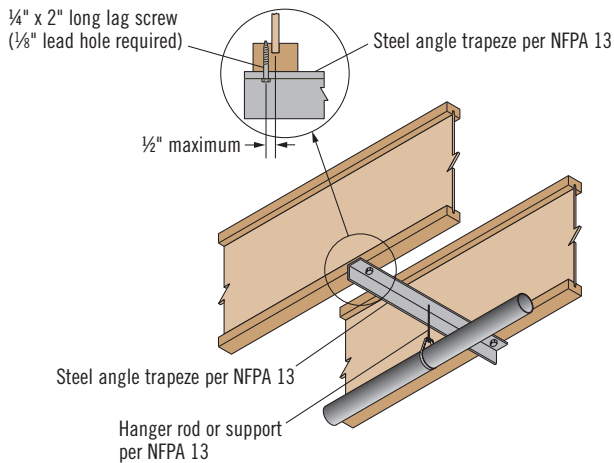

At maximum hanger spacing, maximum pipe diameter is 4". Center pipe support (parallel or perpendicular) between joists.

S28 U-Hook with Filler Block

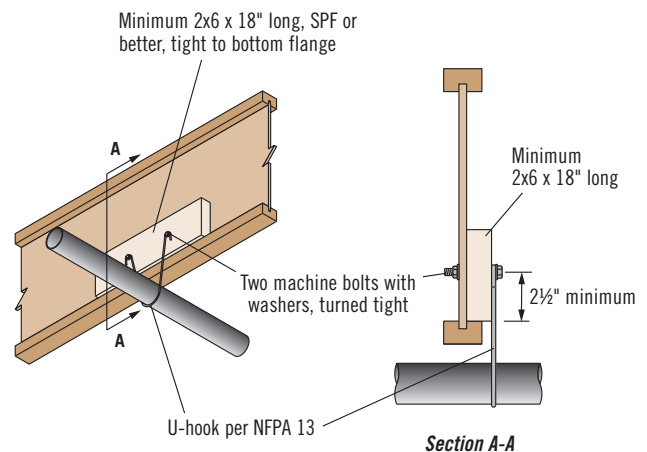

At maximum hanger spacing, maximum pipe diameter is 3 1/2" for 3/8" bolts, 4" for 1/2" bolts.

TJI® JOIST SPRINKLER DETAILS (STEEL PIPE)

S29 U-Hook with Support Member

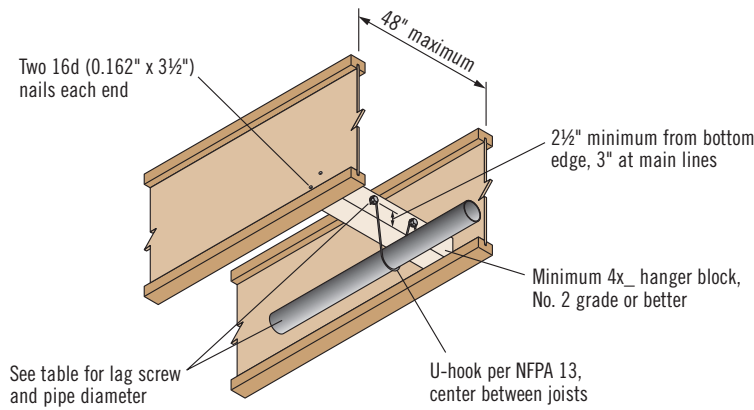

Block Material	Lag Screw Size	Maximum Pipe Diameter
DF or SP	3/8" x 2 1/2"	3 1/2"
	1/2" x 3"	4"
SPF or HF	3/8" x 2 1/2"	3 1/2"
	1/2" x 3"	4"

Center pipe support (parallel or perpendicular) between joists.

S30 Pipe on Support Member

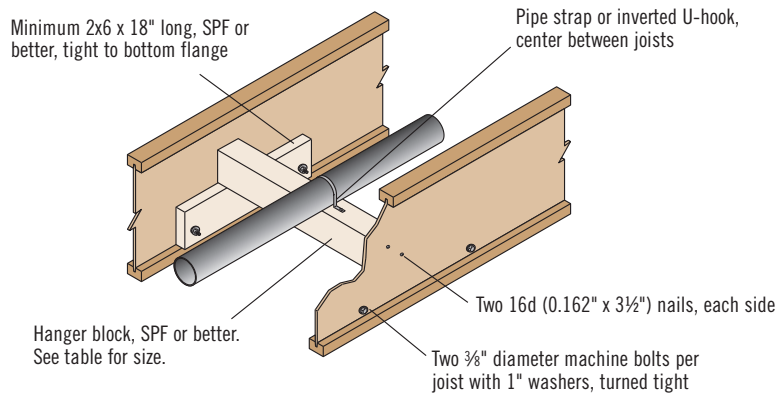

TJI® Joist On-Center Spacing	Wood Hanger Block Size
32" or less	4x4
48"	4x6

At maximum hanger spacing, maximum pipe diameter is 6".

S31 Inverted U-Hook with Pipe Through TJI® Joist (4" Pipe Diameter, Maximum)

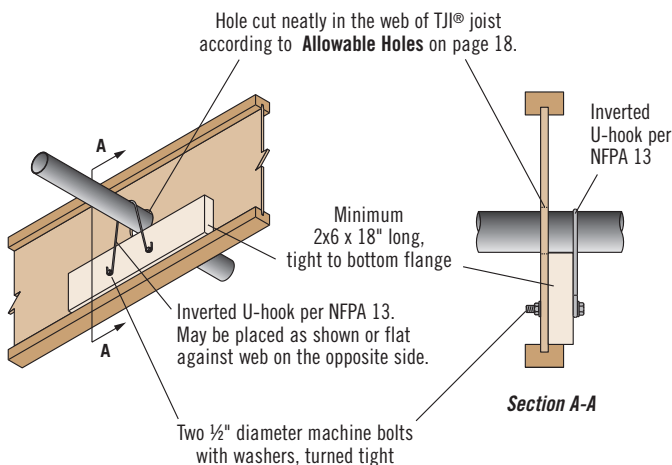

S32 Inverted U-Hook with Pipe Through TJI® Joist (6" Pipe Diameter, Maximum)

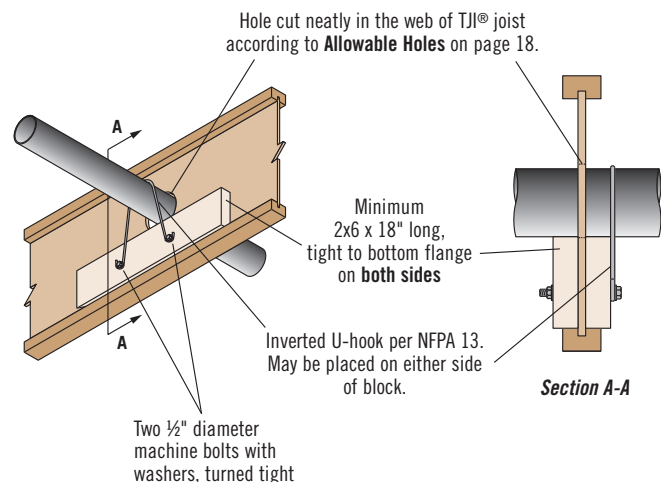

TJI® JOIST SPRINKLER DETAILS (SEISMIC)

S50 Swivel Sway Brace on TJI® Joist Web (Loads Parallel or Perpendicular to TJI® Joists)

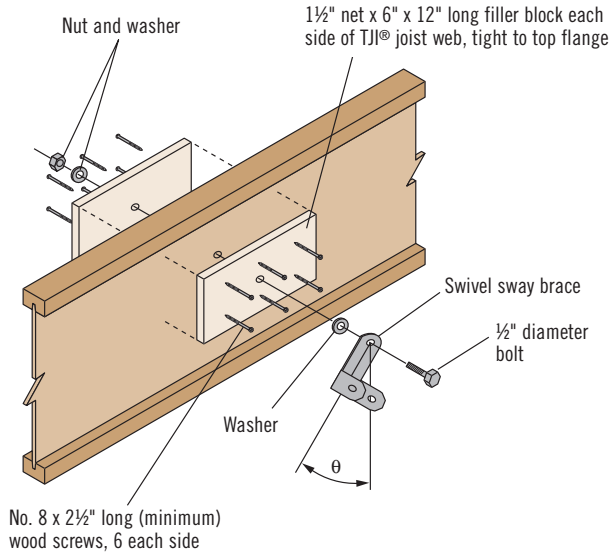

Allowable Horizontal Seismic Loads (lbs)

Species	Angle to Vertical (θ)		
	30°	45°	60°
DF	430	690	695
SPF	365	590	695

- Loads are based on the controlling connection to the joist.
- Loads include a 1.60 duration of load factor adjustment.

S51 Extended Swivel Sway Brace on TJI® Joist Web (Loads Parallel to TJI® Joists)

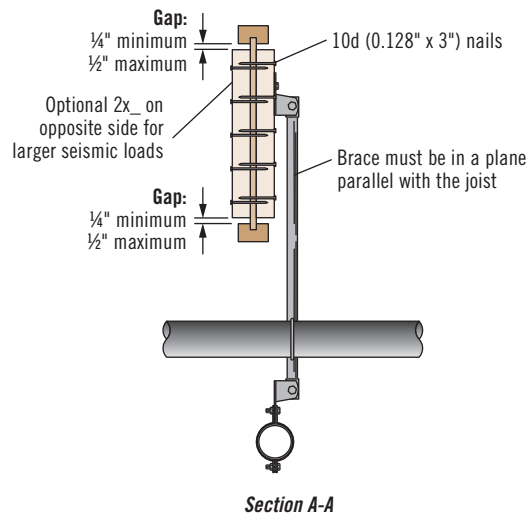
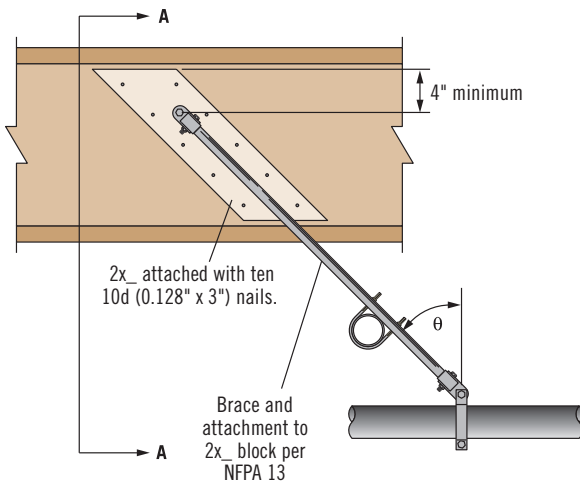

General Notes

- Do not use this detail for loads perpendicular to the joist.
- Make connection in top half of block, centered at least 4" from the end of the block.
- The direction of the wood grain in the block is approximately parallel with the brace.

Allowable Horizontal Seismic Loads (lbs)

Species	Blocking Condition	Angle to Vertical (θ)		
		30°	45°	60°
DF	2x_ on one side	465	660	810
	2x_ on both sides	660	935	1,145
SPF	2x_ on one side	410	580	710
	2x_ on both sides	615	865	1,060

- Loads are based on the controlling connection to the joist.
- Loads include a 1.60 duration of load factor adjustment.

TJI® JOIST SPRINKLER DETAILS (SEISMIC)

S52 Brace with Nailed Blocking (Loads Parallel or Perpendicular to TJI® Joists)

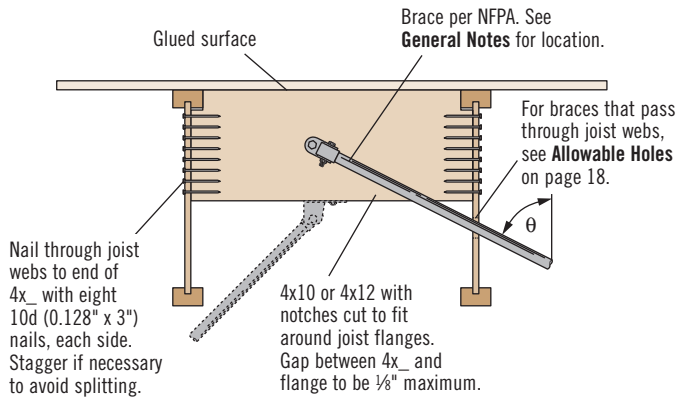

General Notes

- Notch top corners of 4x blocking so it fits around joist flanges and tight to sheathing.
- Before installing, glue top edge of 4x blocking with a subfloor adhesive that meets the requirements of ASTM D 3498. Follow manufacturer's recommendations. Glued surfaces must be clean and dust free.
- For loads perpendicular to joists, the brace must be located a distance of at least 7 x the hole diameter used for brace attachment, measured from the end of the block. Maintain a 4-hole-diameter distance from all other edges.
- For loads parallel to joists (not shown), the brace must be attached to the upper half of the 4x blocking. The same end and edge distances as those noted above for loads perpendicular to joist must also be maintained.

Allowable Horizontal Seismic Loads (lbs)

Species	Angle to Vertical (θ)		
	30°	45°	60°
DF	370 ⁽¹⁾	600	600
SPF	340 ⁽¹⁾	590 ⁽²⁾	600

- (1) If connection is centered within the length of the 4x block, loads may be increased to 400 lbs.
 (2) If connection is centered within the length of the 4x block, loads may be increased to 600 lbs.
- Loads are based on the controlling connection to the joist.
 - The capacity of the brace fastener to the wood block may limit the capacity of the detail (see NFPA 13).
 - Loads include a 1.60 duration of load factor adjustment.

S53 Brace with Blocking in Hangers (Loads Parallel or Perpendicular to TJI® Joists)

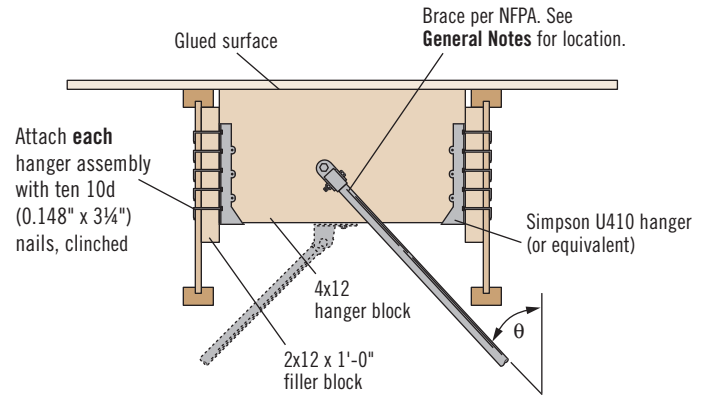

General Notes

- Before installing, glue top edge of 4x blocking with a subfloor adhesive that meets the requirements of ASTM D 3498. Follow manufacturer's recommendations. Glued surfaces must be clean and dust free.
- Attach 4x hanger block by nailing through each hanger, filler block, and TJI® joist web with ten 10d (0.148" x 3") nails and clinch.
- For loads perpendicular to joists, the brace must be located a distance of at least 7 x the hole diameter used for brace attachment, measured from the end of the block. Maintain a 4-hole-diameter distance from all other edges.
- For loads parallel to joists (not shown), the brace must be attached to the upper half of the 4x blocking. The same end and edge distances as those noted above for loads perpendicular to joist must also be maintained.

Allowable Horizontal Seismic Loads (lbs)

Species	Angle to Vertical (θ)		
	30°	45°	60°
DF	465	720	980
SPF	400	650	895

- Loads are based on the controlling connection to the joist.
- The capacity of the brace fastener to the wood block may limit the capacity of the detail (see NFPA 13).
- Loads include a 1.60 duration of load factor adjustment.

WE CAN HELP YOU BUILD SMARTER

You want to build solid and durable structures—we want to help. Weyerhaeuser provides high-quality building products and unparalleled technical and field assistance to support you and your project from start to finish.

Floors and Roofs: Start with the best framing components in the industry: our Trus Joist® TJI® joists; TimberStrand® LSL rim board; and TimberStrand® LSL, Microllam® LVL, and Parallam® PSL headers and beams. Pull them all together with our self-gapping and self-draining Weyerhaeuser Edge Gold™ floor panels and durable Weyerhaeuser roof sheathing.

Walls: Get the best value out of your framing package—use TimberStrand® LSL studs for tall walls, kitchens, and bathrooms, and our traditional, solid-sawn lumber everywhere else. Cut down installation time by using TimberStrand® LSL headers for doors and windows, and Weyerhaeuser wall sheathing with its handy two-way nail lines.

Software Solutions: Whether you are a design professional or lumber dealer, Weyerhaeuser offers an array of software packages to help you specify individual framing members, create cut lists, manage inventories—even help you design a complete structural frame. Contact your Weyerhaeuser representative to find out how to get the software you need.

Technical Support: Need technical help? Weyerhaeuser has one of the largest networks of engineers and sales representatives in the business. Call us for help, and a skilled member from our team of experts will answer your questions and work with you to develop solutions that meet all your structural framing needs.

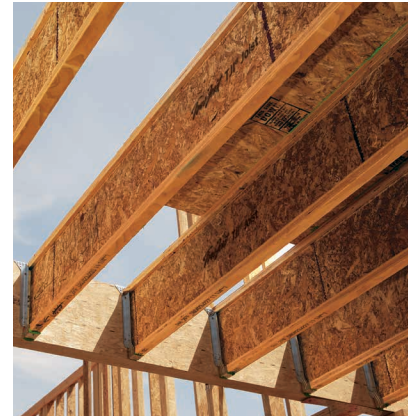

Have a damaged joist or beam?

File a damage report online for prompt service from your regional technical office. Scan the QR code with your smartphone or go to weyerhaeuser.com/woodproducts/support.

LIMITED LIFETIME PRODUCT WARRANTY

Weyerhaeuser provides limited lifetime warranties for all Trus Joist® branded products. Product information, installation instructions, and the full text of each product's limited warranty (including limitations and exclusions) are available on the Weyerhaeuser website, from your Weyerhaeuser representative, or by calling toll free: 888-453-8358.

Additionally, Weyerhaeuser offers limited warranties on a broad variety of its other products. To see complete details of all Weyerhaeuser product warranties, visit weyerhaeuser.com/woodproducts/warranty.

1.888.453.8358
[WEYERHAEUSER.COM/WOODPRODUCTS](http://weyerhaeuser.com/woodproducts)

Weyerhaeuser and Trus Joist are registered trademarks of Weyerhaeuser NR Company. All rights reserved. © 2025 Weyerhaeuser NR Company. All rights reserved. Printed in the USA.

CONTACT US

1.888.453.8358 • weyerhaeuser.com/woodproducts/contact

Contact your local representative or dealer at:

Visit weyerhaeuser.com/woodproducts/warranty for copies of this and other Trus Joist® Engineered Wood Product warranties.

February 2025 • Reorder TJ-1500

This document supersedes all previous versions. If this is more than one year old, contact your dealer or Weyerhaeuser rep.

▲ Weyerhaeuser, Forte, Javelin, Microllam, Parallam, TimberStrand, TJ, TJI, and Trus Joist are registered trademarks and Edge Gold, and TJ-Pro are trademarks of Weyerhaeuser NR. © 2025 Weyerhaeuser NR Company. All rights reserved. Printed in the USA.