

Self-Tapping Screws Head Dimensions

Truss & Wafer

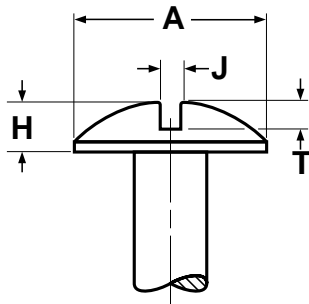

Slotted

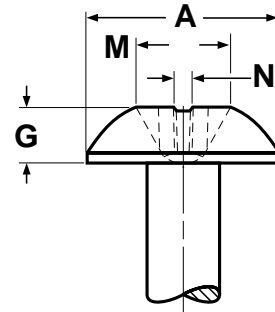

Phillips

TRUSS HEADS FOR SELF-TAPPING SCREWS

ASME B18.6.4

Nominal Size	A		H		J		T		M		G	N	Phillips Driver Size
	Head Diameter		Height of Head		Slot Width		Slot Depth		Dimensions of Recess				
									Diameter	Depth	Width		
	Max	Min	Max	Min	Max	Min	Max	Min	Max	Min	Max		
2	.194	.180	.053	.044	.031	.023	.031	.022	.104	.091	.050	.018	1
4	.257	.241	.069	.059	.039	.031	.040	.030	.112	.099	.069	.018	1
5	.289	.272	.078	.066	.043	.035	.045	.034	.128	.115	.076	.019	1
6	.321	.303	.086	.074	.048	.039	.050	.037	.158	.145	.084	.027	2
7	.352	.333	.094	.081	.048	.039	.054	.041	.165	.152	.078	.028	2
8	.384	.364	.102	.088	.054	.045	.058	.045	.173	.160	.099	.029	2
10	.448	.425	.118	.103	.060	.050	.068	.053	.188	.175	.115	.030	2
12	.511	.487	.134	.118	.067	.056	.077	.061	.248	.235	.128	.032	3
1/4	.573	.546	.150	.133	.075	.064	.087	.070	.263	.250	.143	.033	3
5/16	.698	.666	.183	.162	.084	.072	.106	.085	.352	.339	.193	.059	4
3/8	.823	.787	.215	.191	.094	.081	.124	.100	.383	.370	.226	.063	4

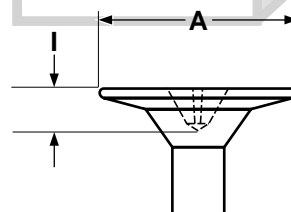
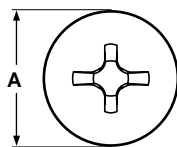

WAFER HEADS FOR SELF-DRILLING SCREWS

Nominal Size	A		I	
	Head Diameter		Recess Depth	
	Max.	Min.	Max.	Min.
10	.516	.441	.134	.094

NOTE: There is no single standard for Wafer head dimensions. These values are offered as a guide; deviations from these specifications may occur.