



RED HEAD®

G5+

SUBMITTAL PACKAGE

**VERSATILE ADHESIVE ANCHORS FOR
CONCRETE AND MASONRY APPLICATIONS**

Adhesive Anchoring Selection Guide



Doweling into Concrete with Rebar



Fastening to Concrete with Threaded Rod

Solid Concrete Applications

PRODUCT SYSTEMS	KEY FEATURES	PROPERTIES	STRENGTH DESIGN PERFORMANCE ¹																					
<p>A7+ The Most Versatile Quick Cure</p> <p>Works in more applications than the competition</p> <p>5 fluid oz. (150 ml) kit, 9.5 fluid oz. (280 ml) and 28 fluid oz. (825 ml) cartridges</p> 	<ul style="list-style-type: none"> The only quick-cure ICC-ES listed for use in all wet conditions Qualified for use in concrete, block, brick, and clay tile. Solid or hollow base materials Cures in only 45 minutes (at substrate temperature of 70°F/21°C) ICC-ES listing for cracked concrete and seismic applications (ICC-ES ESR 3903) ICC-ES listing for masonry applications (ICC-ES ESR 3951) No drip formula that allows direct-injection overhead installation 18 month shelf life NSF/ANSI 61 	<table border="1"> <thead> <tr> <th>BASE MATERIAL (F°/C°)</th> <th>GEL/WORKING TIME</th> <th>FULL CURE TIME</th> </tr> </thead> <tbody> <tr> <td>110°/ 43°</td> <td>1.5 minutes</td> <td>45 minutes</td> </tr> <tr> <td>90°/ 32°</td> <td>3 minutes</td> <td>45 minutes</td> </tr> <tr> <td>70°/ 21°</td> <td>5 minutes</td> <td>45 minutes</td> </tr> <tr> <td>50°/ 10°</td> <td>15 minutes</td> <td>90 minutes</td> </tr> <tr> <td>30°/ -1°</td> <td>35 minutes</td> <td>4 hours</td> </tr> <tr> <td>14°/ -10°</td> <td>35 minutes</td> <td>24 hours</td> </tr> </tbody> </table>	BASE MATERIAL (F°/C°)	GEL/WORKING TIME	FULL CURE TIME	110°/ 43°	1.5 minutes	45 minutes	90°/ 32°	3 minutes	45 minutes	70°/ 21°	5 minutes	45 minutes	50°/ 10°	15 minutes	90 minutes	30°/ -1°	35 minutes	4 hours	14°/ -10°	35 minutes	24 hours	<p>NSF[®] Certified to ANS/NSF 61</p>
BASE MATERIAL (F°/C°)	GEL/WORKING TIME	FULL CURE TIME																						
110°/ 43°	1.5 minutes	45 minutes																						
90°/ 32°	3 minutes	45 minutes																						
70°/ 21°	5 minutes	45 minutes																						
50°/ 10°	15 minutes	90 minutes																						
30°/ -1°	35 minutes	4 hours																						
14°/ -10°	35 minutes	24 hours																						
<p>C6+ For the Most Demanding Jobs</p> <p>Red Head's highest strength adhesive</p> <p>MADE IN USA WITH U.S. AND GLOBAL MATERIALS</p> <p>15.2 fluid oz. (450 ml) cartridges and 30.4 fluid oz. (900 ml) cartridges</p> 	<ul style="list-style-type: none"> At least 25% stronger than the old C6+ formulation for threaded rod in cracked concrete and with seismic conditions Fastest Cure time in its class, curing in just 2.75 hours at 90°F and in only 2 hours at 110°F! ICC-ES listing for concrete (uncracked and cracked concrete, and seismic conditions) and masonry ICC-ES listing for use in core-drill holes, even in cracked concrete Can be used in oversized holes Can be used in all wet conditions (saturated, water-filled, and submerged) European fire approval 24 month shelf life NSF/ANSI 61 	<table border="1"> <thead> <tr> <th>BASE MATERIAL (F°/C°)</th> <th>GEL/WORKING TIME</th> <th>FULL CURE TIME</th> </tr> </thead> <tbody> <tr> <td>110°/ 43°</td> <td>10 minutes</td> <td>2 hours</td> </tr> <tr> <td>90°/ 32°</td> <td>14 minutes</td> <td>2.75 hours</td> </tr> <tr> <td>70°/ 21°</td> <td>16 minutes</td> <td>6.5 hours</td> </tr> <tr> <td>50°/ 13°</td> <td>30 minutes</td> <td>24 hours</td> </tr> <tr> <td>40°/ 7°</td> <td>46 minutes</td> <td>48 hours</td> </tr> </tbody> </table>	BASE MATERIAL (F°/C°)	GEL/WORKING TIME	FULL CURE TIME	110°/ 43°	10 minutes	2 hours	90°/ 32°	14 minutes	2.75 hours	70°/ 21°	16 minutes	6.5 hours	50°/ 13°	30 minutes	24 hours	40°/ 7°	46 minutes	48 hours	<p>NSF[®] Certified to ANS/NSF 61</p>			
BASE MATERIAL (F°/C°)	GEL/WORKING TIME	FULL CURE TIME																						
110°/ 43°	10 minutes	2 hours																						
90°/ 32°	14 minutes	2.75 hours																						
70°/ 21°	16 minutes	6.5 hours																						
50°/ 13°	30 minutes	24 hours																						
40°/ 7°	46 minutes	48 hours																						
<p>G5+ Everyday Epoxy</p> <p>Economical general-purpose adhesive</p> <p>MADE IN USA WITH U.S. AND GLOBAL MATERIALS</p> <p>15.2 fluid oz. (450 ml) cartridges and 30.4 fluid oz. (900 ml) cartridges</p> 	<ul style="list-style-type: none"> At least 50% stronger than the old G5 formulation for threaded rod in cracked concrete and with seismic conditions Cures 3x faster than the old G5 formula Now works down to 40°F ICC-ES listing for concrete (uncracked and cracked concrete, and seismic conditions) Formulated for warm weather with at least 10 minutes of nozzle life Can be used in oversized holes Can be used in all wet conditions (saturated, water-filled, and submerged) 24 month shelf life NSF/ANSI 61 	<table border="1"> <thead> <tr> <th>BASE MATERIAL (F°/C°)</th> <th>GEL/WORKING TIME</th> <th>FULL CURE TIME</th> </tr> </thead> <tbody> <tr> <td>110°/ 43°</td> <td>10 minutes</td> <td>4 hours</td> </tr> <tr> <td>90°/ 32°</td> <td>14 minutes</td> <td>6 hours</td> </tr> <tr> <td>70°/ 21°</td> <td>16 minutes</td> <td>8 hours</td> </tr> <tr> <td>50°/ 13°</td> <td>30 minutes</td> <td>30 hours</td> </tr> <tr> <td>40°/ 7°</td> <td>46 minutes</td> <td>48 hours</td> </tr> </tbody> </table>	BASE MATERIAL (F°/C°)	GEL/WORKING TIME	FULL CURE TIME	110°/ 43°	10 minutes	4 hours	90°/ 32°	14 minutes	6 hours	70°/ 21°	16 minutes	8 hours	50°/ 13°	30 minutes	30 hours	40°/ 7°	46 minutes	48 hours	<p>NSF[®] Certified to ANS/NSF 61</p>			
BASE MATERIAL (F°/C°)	GEL/WORKING TIME	FULL CURE TIME																						
110°/ 43°	10 minutes	4 hours																						
90°/ 32°	14 minutes	6 hours																						
70°/ 21°	16 minutes	8 hours																						
50°/ 13°	30 minutes	30 hours																						
40°/ 7°	46 minutes	48 hours																						

¹Diameter x Embedment in 4000 psi concrete. All loads given in pounds. Calculated using the ICC-ES threaded rod data in uncracked, dry concrete with periodic inspection. Temperature range A.
*Red head A7+ replaced Epcon A7 and S7. Red Head C6+ replaced Epcon C6+, and Red Head G5+ replaced Epcon G5. For more information on the retired adhesives (Epcon A7, S7, C6+ and G5), please visit www.itwredhead.com

Hollow Base Material Applications

Use the following accessories with the A7+ adhesive anchoring system for all of your hollow base material applications.

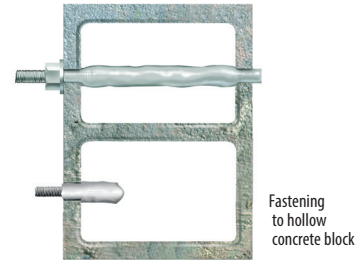
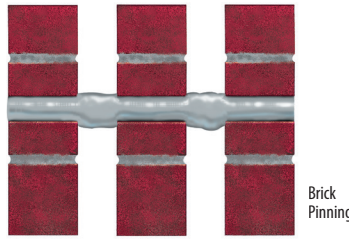

SYSTEM ACCESSORIES	KEY FEATURES	ULTIMATE TENSILE ^{1,2} PERFORMANCE (LBS.)						
<h2>Umbrella Anchor</h2>  <p>Umbrella Anchor</p> <p>Makes it possible to use adhesive for fastening to the face of hollow block or tile (see page 53)</p>	<ul style="list-style-type: none"> Highest hold in hollow block 1/4", 3/8", or 1/2" rods Fasten to front face of blocks Creates large bearing surface inside block to achieve high loads 	<p>A7+</p>  <table border="1"> <tr> <th>Diameter</th> <th>Tensile (LBS.)</th> </tr> <tr> <td>3/8"</td> <td>3,558</td> </tr> <tr> <td>1/2"</td> <td>3,558</td> </tr> </table>	Diameter	Tensile (LBS.)	3/8"	3,558	1/2"	3,558
Diameter	Tensile (LBS.)							
3/8"	3,558							
1/2"	3,558							
<h2>Nylon Screens</h2>  <p>Makes it possible to use adhesive for fastening to hollow block or brick walls (see page 56)</p>	<ul style="list-style-type: none"> 3/8" to 3/4" diameter sizes 30%-50% lower cost than stainless screens Special design makes screens easier to insert through block or brick Does not get bent or crushed Corrosion resistant 	<p>A7+</p>  <table border="1"> <tr> <th>Size</th> <th>Tensile (LBS.)</th> </tr> <tr> <td>3/8" x 8"</td> <td>2,360</td> </tr> <tr> <td>3/4" x 8"</td> <td>2,647</td> </tr> </table>	Size	Tensile (LBS.)	3/8" x 8"	2,360	3/4" x 8"	2,647
Size	Tensile (LBS.)							
3/8" x 8"	2,360							
3/4" x 8"	2,647							
<h2>Stainless Steel Screens</h2>  <p>Makes it possible to use adhesive for fastening to hollow block or brick walls (see page 56)</p>	<ul style="list-style-type: none"> 1/4" & 3/4" diameter sizes Corrosion resistant Available in 1/4" thicknesses 	<p>A7+</p>  <table border="1"> <tr> <th>Size</th> <th>Tensile (LBS.)</th> </tr> <tr> <td>3/8" x 8"</td> <td>2,360</td> </tr> <tr> <td>3/4" x 8"</td> <td>2,647</td> </tr> </table>	Size	Tensile (LBS.)	3/8" x 8"	2,360	3/4" x 8"	2,647
Size	Tensile (LBS.)							
3/8" x 8"	2,360							
3/4" x 8"	2,647							
<h2>Stubby Screens</h2>  <p>Makes it possible to use adhesive for fastening to the face of hollow block or tile (see page 53)</p>	<ul style="list-style-type: none"> 1/4", 3/8", 1/2", 5/8" diameter sizes Fasten to front face of block Anchor remains perpendicular in wall 	<p>A7+</p>  <table border="1"> <tr> <th>Diameter</th> <th>Tensile (LBS.)</th> </tr> <tr> <td>1/2"</td> <td>2,458</td> </tr> <tr> <td>5/8"</td> <td>2,543</td> </tr> </table>	Diameter	Tensile (LBS.)	1/2"	2,458	5/8"	2,543
Diameter	Tensile (LBS.)							
1/2"	2,458							
5/8"	2,543							

¹ Testing performed in hollow concrete block.

² Diameter x Embedment.

G5+

Everyday Epoxy



G5P-15

G5P-30



**MADE IN USA
WITH U.S. AND
GLOBAL MATERIALS**

DESCRIPTION/SUGGESTED SPECIFICATIONS*

Economical, general-purpose adhesive for warm-weather anchoring applications

Red Head G5+ is a reliable general-purpose adhesive that is backed by many DOT approvals and ICC-ES listings for cracked, uncracked concrete, and seismic conditions. The new G5+ is also Buy American compliant and helps to support jobs here in the U.S.

- At least 50% stronger than the old Epcon G5 for threaded rod in cracked concrete and with seismic conditions
- Cures 3x faster than the old Epcon G5 formula
- Now works down to 40F, and all the way up to 110F
- ICC-ES approved for concrete (uncracked and cracked concrete, and all seismic conditions)
- At least 10 minutes of nozzle life (10 mins. at 110°F)
- Made In USA with U.S. and Global Components
- Can be used in oversized holes
- 24-month shelf life
- NSF/ANSI 61
- Store between 50°F and 95°F in a cool, dry place

ADVANTAGES

- Get more pull out strength with Red Head G5+ vs. other general-purpose adhesives (per ICC-ES reports)
- Continue to work on chilly mornings, with curing abilities now down to 40°F
- ICC-ES approved for all wet conditions (including underwater)
- More time to set anchors in warm weather with at least 10 minutes of nozzle life
- More safe and durable on job sites than sausage packs
- Help support US jobs with G5+

Cure and Gel Times

BASE MATERIAL (F°/C°)	GEL TIME ²	FULL CURE TIME
110°/ 43°	10 minutes	4 hours
90°/ 32°	14 minutes	6 hours
70°/ 21°	16 minutes	8 hours
50°/ 10°	30 minutes	30 hours
40°/ 4.4°	46 minutes	48 hours

APPROVALS/LISTINGS

- ICC-ES ESR 4138 (Concrete Report)
- 2015, 2012, 2009, 2006 International Building Code (IBC) Compliant
- Florida Building Code (FBC)
- City of Los Angeles (COLA)
- Extensive Department of Transportation (DOT) Listings
- NSF/ANSI 61 Approval for use in Drinking Water System Components
- ASTM C881, Types I, II, IV, and V, Grade 3, Classes B & C

For the most current approvals/listings visit:
www.ITW-RedHead.com

INSTALLATION STEPS for Carbide-Tipped Bits*

DRILL

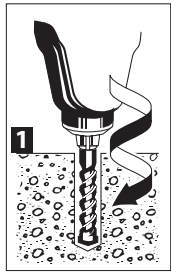

BLOW**

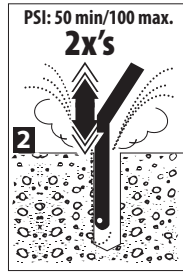

BRUSH

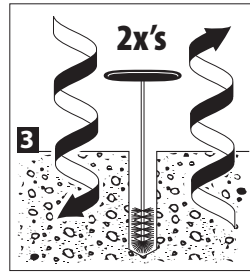

BLOW**

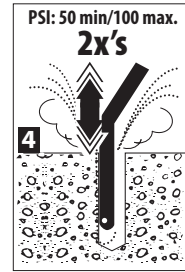

DISPENSE***

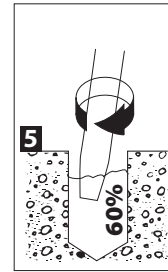

INSTALL

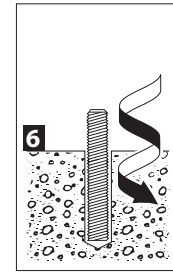

* Damp, submerged and underwater applications require 4x's air, 4x's brushing and 4x's air







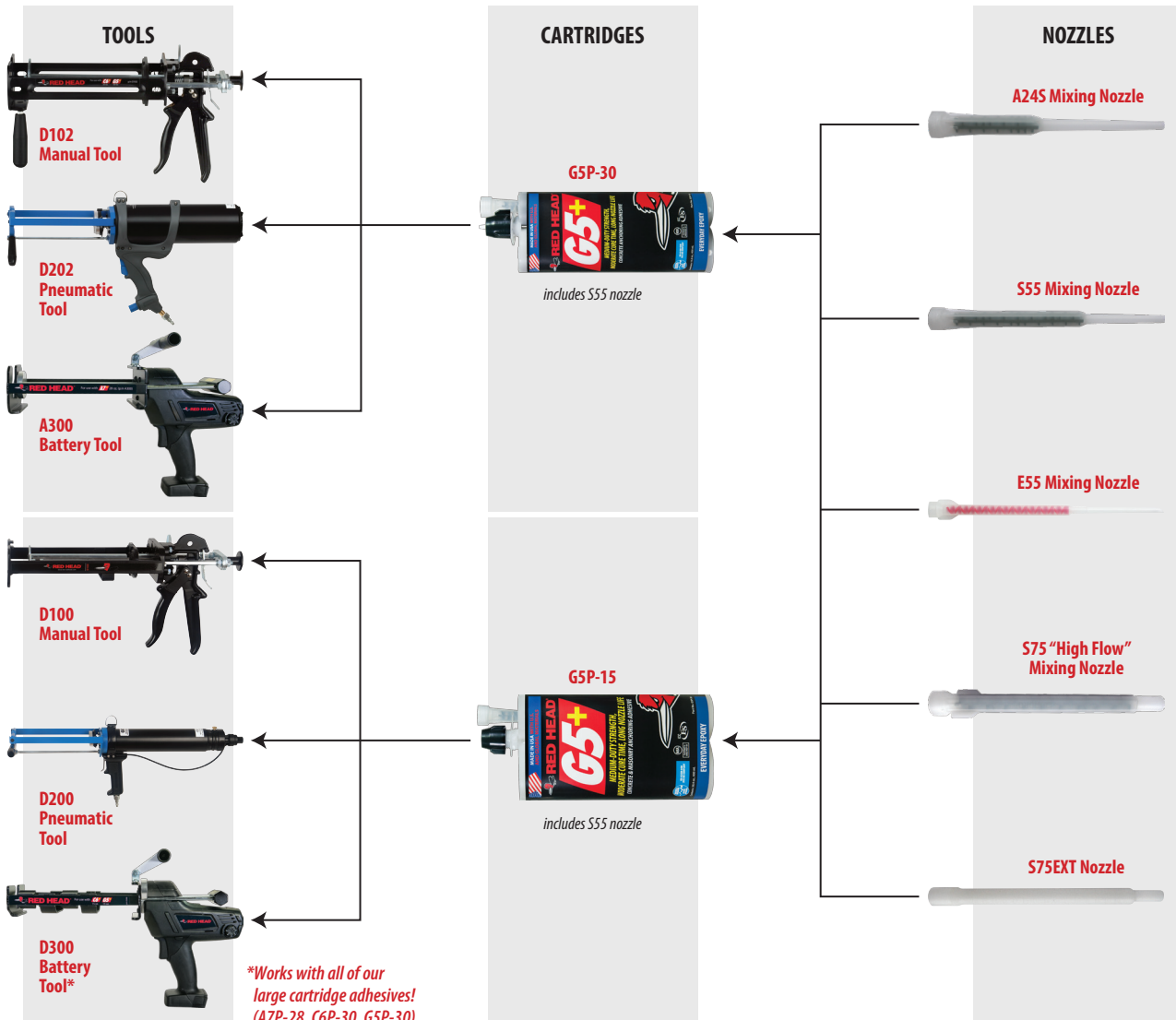

** Dust is shown for diagram purposes only. To help mitigate airborne dust and comply with OSHA requirements, we recommend that you either wet the concrete before blowing out the hole, or use a drill dust extractor with your pneumatic air nozzle. We recommend vacuum assisted dust extractors like Milwaukee part numbers 5261-DE or 5317-DE. Call our technical services at (800) 848-5611 for more information.

*** Dispense mixed adhesive outside of hole until uniform color is achieved.

Selection Guide



G5P-30.4 fl. oz. Ordering Information

PART NUMBER	DESCRIPTION	BOX QTY	PART NUMBER	DESCRIPTION	BOX QTY
 G5P-30	30.4 Fluid Ounce Red Head C6+ Cartridge with S55 Nozzle	4	 D202	Pneumatic Dispenser for C6P-30 and G5P-30 cartridges	1
 D102	Heavy-Duty 34:1 thrust ratio hand dispenser for C6P-30 and G5P-30 cartridges	1	 A300	Cordless Battery Dispenser for A7P-28, C6P-30 and G5P-30 Cartridge. Includes one battery and charger. Works with all Milwaukee® M18™ batteries	1
 S55	Standard Mixing Nozzle, fits holes for 3/8" diameter anchors and larger. 3-1/2" inch usable length for 3/8" and 1/2" anchors, 8-1/4" usable length for 5/8" anchors and above	24	 S75	High Flow Mixing Nozzle, fits holes for 3/4" diameter anchors and larger. 7-3/8" usable length	24
 E55	Long Mixing Nozzle, fits holes for 3/8" diameter anchors and larger. 5-3/4" inch usable length for 3/8" and 1/2" anchors, 12-5/8" usable length for 5/8" anchors and above	24	 S75EXT	Extension for High Flow Mixing Nozzle for 3/4" diameter anchors and larger. 15-5/8" usable length when attached to S75	24

*See page 65 for nozzle extension tubes and other accessories









ESTIMATING TABLES

G5P-30 Number of Anchoring Installations Per Cartridge* Using 30.4 Fluid Ounce Cartridge **Threaded Rod or Rebar with G5+ Adhesive in Solid Concrete**

ANCHOR DIA. in.	# rebar	DRILL HOLE DIA. (in.)	NUMBER OF ANCHORING INSTALLATIONS PER CARTRIDGE* USING THREADED ROD OR REBAR WITH C6+ ADHESIVE IN SOLID CONCRETE														
			1	2	3	4	5	6	7	8	9	10	11	12	13	14	15
3/8	#3	7/16	608.9	304.5	203.0	152.2	121.8	101.5	87.0	76.1	67.7	60.9	55.4	50.7	46.8	43.5	40.6
1/2		9/16	368.3	184.2	122.8	92.1	73.7	61.4	52.6	46.0	40.9	36.8	33.5	30.7	28.3	26.3	24.6
	#4	5/8	298.4	149.2	99.5	74.6	59.7	49.7	42.6	37.3	33.2	29.8	27.1	24.9	23.0	21.3	19.9
5/8	#5	3/4	207.2	103.6	69.1	51.8	41.4	34.5	29.6	25.9	23.0	20.7	18.8	17.3	15.9	14.8	13.8
3/4	#6	7/8	152.2	76.1	50.7	38.1	30.4	25.4	21.7	19.0	16.9	15.2	13.8	12.7	11.7	10.9	10.1
7/8	#7	1	116.5	58.3	38.8	29.1	23.3	19.4	16.6	14.6	12.9	11.7	10.6	9.7	9.0	8.3	7.8
1	#8	1-1/8	92.1	46.0	30.7	23.0	18.4	15.3	13.2	11.5	10.2	9.2	8.4	7.7	7.1	6.6	6.1
	#9	1-1/4	74.6	37.3	24.9	18.6	14.9	12.4	10.7	9.3	8.3	7.5	6.8	6.2	5.7	5.3	5.0
1-1/4		1-3/8	61.6	30.8	20.5	15.4	12.3	10.3	8.8	7.7	6.8	6.2	5.6	5.1	4.7	4.4	4.1
	#10	1-1/2	51.8	25.9	17.3	12.9	10.4	8.6	7.4	6.5	5.8	5.2	4.7	4.3	4.0	3.7	3.5
1-1/2"		1-5/8"	44.1	22.1	14.7	11.0	8.8	7.4	6.3	5.5	4.9	4.4	4.0	3.7	3.4	3.2	2.9
	#11	1-3/4	38.1	19.0	12.7	9.5	7.6	6.3	5.4	4.8	4.2	3.8	3.5	3.2	2.9	2.7	2.5

*The estimated number of anchoring installations per cartridge is based upon calculations of filling the hole 60% full of adhesive per the recommendation in our installation instructions. Hole volumes are calculated using ANSI tolerance carbide tipped drill bits. These estimates do not account for any waste.

G5P-15 fl. oz. Ordering Information

PART NUMBER	DESCRIPTION	BOX QTY	PART NUMBER	DESCRIPTION	BOX QTY
 G5P-15	15.2 Fluid Ounce Red Head C6+ Cartridge with S55 Nozzle	4	 D200	Ergonomic Pneumatic Dispenser for C6P-15 and G5P-15 cartridges	1
 D100	Heavy-Duty 34:1 thrust ratio hand dispenser for C6P-15 and G5P-15 cartridges	1	 D300	Cordless Battery Dispenser for C6P-15 and G5P-15 Cartridge. Includes one battery and charger. Works with all Milwaukee® M18™ batteries	1
 S55	Standard Mixing Nozzle, fits holes for 3/8" diameter anchors and larger. 3-1/2" inch usable length for 3/8" and 1/2" anchors, 8-1/4" usable length for 5/8" anchors and above	24	 S75	High Flow Mixing Nozzle, fits holes for 3/4" diameter anchors and larger. 7-3/8" usable length	24
 E55	Long Mixing Nozzle, fits holes for 3/8" diameter anchors and larger. 5-3/4" inch usable length for 3/8" and 1/2" anchors, 12-5/8" usable length for 5/8" anchors and above	24	 S75EXT	Extension for High Flow Mixing Nozzle for 3/4" diameter anchors and larger. 15-5/8" usable length when attached to S75	24

*See page 65 for nozzle extension tubes and other accessories

ESTIMATING TABLES

G5P-15 Number of Anchoring Installations Per Cartridge* Using **15.2 Fluid Ounce Cartridge** Threaded Rod or Rebar with G5+ Adhesive in Solid Concrete

ANCHOR DIA. in.	# rebar	DRILL HOLE DIA. (in.)	EMBEDMENT DEPTH IN INCHES														
			1	2	3	4	5	6	7	8	9	10	11	12	13	14	15
3/8	#3	7/16	304.5	152.2	101.5	76.1	60.9	50.7	43.5	38.1	33.8	30.4	27.7	25.4	23.4	21.7	20.3
1/2		9/16	184.2	92.1	61.4	46.0	36.8	30.7	26.3	23.0	20.5	18.4	16.7	15.3	14.2	13.2	12.3
	#4	5/8	149.2	74.6	49.7	37.3	29.8	24.9	21.3	18.6	16.6	14.9	13.6	12.4	11.5	10.7	9.9
5/8	#5	3/4	103.6	51.8	34.5	25.9	20.7	17.3	14.8	12.9	11.5	10.4	9.4	8.6	8.0	7.4	6.9
3/4	#6	7/8	76.1	38.1	25.4	19.0	15.2	12.7	10.9	9.5	8.5	7.6	6.9	6.3	5.9	5.4	5.1
7/8	#7	1	58.3	29.1	19.4	14.6	11.7	9.7	8.3	7.3	6.5	5.8	5.3	4.9	4.5	4.2	3.9
1	#8	1-1/8	46.0	23.0	15.3	11.5	9.2	7.7	6.6	5.8	5.1	4.6	4.2	3.8	3.5	3.3	3.1
	#9	1-1/4	37.3	18.6	12.4	9.3	7.5	6.2	5.3	4.7	4.1	3.7	3.4	3.1	2.9	2.7	2.5
1-1/4		1-3/8	30.8	15.4	10.3	7.7	6.2	5.1	4.4	3.9	3.4	3.1	2.8	2.6	2.4	2.2	2.1
	#10	1-1/2	25.9	12.9	8.6	6.5	5.2	4.3	3.7	3.2	2.9	2.6	2.4	2.2	2.0	1.8	1.7
1-1/2"		1-5/8"	22.1	11.0	7.4	5.5	4.4	3.7	3.2	2.8	2.5	2.2	2.0	1.8	1.7	1.6	1.5
	#11	1-3/4	19.0	9.5	6.3	4.8	3.8	3.2	2.7	2.4	2.1	1.9	1.7	1.6	1.5	1.4	1.3

*The estimated number of anchoring installations per cartridge is based upon calculations of filling the hole 60% full of adhesive per the recommendation in our installation instructions. Hole volumes are calculated using ANSI tolerance carbide tipped drill bits. These estimates do not account for any waste.



Call our toll free number 800-848-5611 or visit our web site for the most current product and technical information at www.itwredhead.com



ALLOWABLE STRESS DESIGN

G5+ *Average Ultimate Tension and Shear Loads^{1,2,3}* **Everyday Epoxy** *for Threaded Rod Installed in Solid Concrete*

THREADED ROD DIAM. (in.)	EMBEDMENT IN CONCRETE (in.)	MAX. CLAMPING FORCE AFTER PROPER CURE ft./lbs.	ULTIMATE TENSION (lbs.)			ULTIMATE SHEAR (lbs.) 3,000 PSI CONCRETE & HIGHER
			3,000 PSI CONCRETE	5,000 PSI CONCRETE	7,000 PSI CONCRETE	
3/8	1-1/2	9	2,685	2,980	3,275	N/A
	3-3/8		9,890	10,385	10,800	4,420
1/2	2	16	5,160	5,835	6,535	N/A
	4-1/2		17,600	20,245	23,075	9,705
5/8	2-1/2	47	7,280	8,450	9,630	N/A
	5-5/8		22,910	26,575	30,295	16,470
3/4	3	70	10,225	11,450	12,710	N/A
	6-3/4		32,980	37,925	42,855	23,145
7/8	3-1/2	90	12,750	14,665	16,570	N/A
	7-7/8		48,350	58,020	70,200	27,300
1	4	110	15,070	17,335	19,585	N/A
	9		54,780	65,185	75,615	34,665
1-1/4	5	370	31,225	33,095	34,750	N/A
	11-1/4		73,920	86,490	98,600	58,570
1-1/2	13	450	85,920	100,095	114,275	N/A

1. Allowable working loads for the single installations under static loading should not exceed 25% capacity of the ultimate load (to get the allowable load of the anchor rod, divide the ultimate load by 4).

2. Performance values are based on the use of high strength threaded rod (ASTM A193 Gr. B7). The use of lower strength rods will result in lower ultimate tension and shear loads.

3. Linear interpolation may be used for intermediate spacing and edge distances.

ALLOWABLE STRESS DESIGN

G5+ *Allowable Tension Loads¹ for Threaded Rod* **Everyday Epoxy** *Installed In Solid Concrete*

THREADED ROD DIA (in.)	EMBEDMENT IN CONCRETE (in.)	ALLOWABLE TENSION LOAD BASED ON CONCRETE STRENGTH (lbs.)			ALLOWABLE TENSION LOAD BASED ON STEEL STRENGTH (lbs.)		
		3,000 psi concrete	5,000 psi concrete	7,000 psi concrete	ASTM A307	ASTM A193 GRADE B7	ASTM F593 AISI 304 SS
3/8	1-1/2	670	745	815	2,080	4,340	3,995
	3-3/8	2,470	2,595	2,700	2,080	4,340	3,995
1/2	2	1,290	1,455	1,630	3,730	7,780	7,155
	4-1/2	4,400	5,060	5,765	3,730	7,780	7,155
5/8	2-1/2	1,820	2,110	2,405	5,870	12,230	11,250
	5-5/8	5,725	6,640	7,570	5,870	12,230	11,250
3/4	3	2,555	2,860	3,175	8,490	17,690	14,860
	6-3/4	8,245	9,480	10,710	8,490	17,690	14,860
7/8	3-1/2	3,185	3,665	4,140	11,600	25,510	20,835
	7-7/8	12,085	14,505	17,550	11,600	25,510	20,835
1	4	3,765	4,330	4,895	15,180	31,620	26,560
	9	13,695	16,295	18,900	15,180	31,620	26,560
1-1/4	5	7,805	8,270	8,685	23,800	49,580	34,670
	11-1/4	18,480	21,620	24,650	23,800	49,580	34,670
1-1/2	13	21,480	25,025	28,570	33,720	70,250	47,770

1. Use lower value of either bond or steel strength for allowable tension load.

ALLOWABLE STRENGTH DESIGN

G5+ *Allowable Shear Loads¹ for Threaded Rod Installed in Solid Concrete* Everyday Epoxy

THREADED ROD DIA. (in.)	EMBEDMENT IN CONCRETE (in.)	ALLOWABLE SHEAR LOAD BASED ON CONCRETE STRENGTH (lbs.)		ALLOWABLE SHEAR LOAD BASED ON STEEL STRENGTH (lbs.)		
		3,000 psi concrete & higher		ASTM A307	ASTM A193 GRADE B7	ASTM F593 AISI 304 SS
3/8	1-1/2	N/A		1,040	2,170	1,995
	3-3/8	1,105		1,040	2,170	1,995
1/2	2	N/A		1,870	3,895	3,585
	4-1/2	2,455		1,870	3,895	3,585
5/8	2-1/2	N/A		2,940	6,125	5,635
	5-5/8	4,115		2,940	6,125	5,635
3/4	3	N/A		4,250	8,855	7,440
	6-3/4	5,915		4,250	8,855	7,440
7/8	3-1/2	N/A		5,800	12,760	10,730
	7-7/8	7,065		5,800	12,760	10,730
1	4	N/A		7,590	15,810	13,285
	9	8,570		7,590	15,810	13,285
1-1/4	5	N/A		11,900	24,790	18,840
	11-1/4	14,805		11,900	24,790	18,840

1. Use lower value of either concrete or steel strength for allowable shear load.

ALLOWABLE STRENGTH DESIGN

G5+ *Average Ultimate Tension Loads^{1,2,3} for Reinforcing Bar Installed In Solid Concrete* Everyday Epoxy

REINFORCING BAR	EMBEDMENT IN CONCRETE (in.)	ULTIMATE TENSION (lbs.)			ULTIMATE YIELD STRENGTH GRADE 60 REBAR (lbs.)	ULTIMATE TENSILE STRENGTH GRADE 60 REBAR (lbs.)
		3,000 psi concrete	5,000 psi concrete	7,000 psi concrete		
#3	1-1/2	2,685	3,165	3,640	6,600	9,900
	3-3/8	9,960	10,460	10,950		
#4	2	5,465	4,770	5,365	12,000	18,000
	4-1/2	17,600	20,420	23,075		
#5	2-1/2	7,710	9,020	10,240	18,600	27,900
	5-5/8	20,295	23,745	27,070		
#6	3	10,825	12,230	13,455	26,400	39,600
	6-3/4	32,980	38,405	43,855		
#7	3-1/2	13,800	15,875	18,015	36,000	54,000
	7-7/8	51,125	63,090	76,140		
#8	4	17,535	20,170	22,830	47,400	71,100
	9	61,565	73,100	85,015		
#10	5	29,835	31,295	33,205	79,200	114,300
	11-1/4	67,695	79,340	89,655		
#11	13	85,920	100,095	114,275	93,600	140,400

1. Allowable working loads for the single installations under static loading should not exceed 25% capacity of the ultimate load (to get the allowable load of the anchor rod, divide the ultimate load by 4).

2. Performance values are based on the use of ASTM A615 Grade 60 reinforcing bar. The use of lower strength rebar will result in lower ultimate tension loads.

3. SHEAR DATA: Provided the distance from the rebar to the edge of the concrete member exceeds 1.25 times the embedment depth of the rebar, calculate the ultimate shear load for the rebar anchorage as 60% of the ultimate tensile strength of the rebar.

ALLOWABLE STRENGTH DESIGN

G5+ *Adhesive Edge/Spacing Distance Load Factor Summary for Installation of Threaded Rod and Reinforcing Bar^{1,2}* Everyday Epoxy

LOAD FACTOR	DISTANCE FROM EDGE OF CONCRETE	LOAD FACTOR	DISTANCE FROM ANOTHER ANCHOR
Critical Edge Distance—Tension		Critical Spacing—Tension	
100% Tension Load	→ 1.25 x Anchor Embedment (or greater)	100% Tension Load	→ 1.50 x Anchor Embedment (or greater)
Minimum Edge Distance—Tension		Minimum Spacing—Tension	
70% Tension Load	→ 0.50 x Anchor Embedment	75% Tension Load	→ 0.75 x Anchor Embedment
Critical Edge Distance—Shear		Critical Spacing—Shear	
100% Shear Load	→ 1.25 x Anchor Embedment (or greater)	100% Shear Load	→ 1.50 x Anchor Embedment (or greater)
Minimum Edge Distance—Shear		Minimum Spacing—Shear	
30% Shear Load	→ 0.30 x Anchor Embedment	30% Shear Load	→ 0.50 x Anchor Embedment

1. Use linear interpolation for load factors at edge distances or spacing distances between critical and minimum.

2. Anchors are affected by multiple combination of spacing and/or edge distance loading and direction of the loading. Use the product of tension and shear loading factors in design.



Call our toll free number 800-848-5611 or visit our web site for the most current product and technical information at www.itwredhead.com



STRENGTH DESIGN

G5+
Everyday Epoxy

**Tension (lbf) and Shear (lbf) in Uncracked Concrete with
ASTM A193 B7 Threaded Rod^{1,2,3,4}**

ANCHOR DIAMETER (in.)	EMBEDMENT DEPTH (in.)	TENSION (lbf)						SHEAR (lbf) 2500-8000 psi
		2500 psi	3000 psi	4000 psi	5000 psi	6000 psi	7000-8000 psi	
3/8	3 3/8	3,910	3,910	3,910	3,910	3,910	3,910	3,775
	4 1/2	5,215	5,215	5,215	5,215	5,215	5,215	3,775
	7 1/2	7,265	7,265	7,265	7,265	7,265	7,265	3,775
1/2	4 1/2	6,705	6,705	6,705	6,705	6,705	6,705	6,915
	6	8,940	8,940	8,940	8,940	8,940	8,940	6,915
	10	13,305	13,305	13,305	13,305	13,305	13,305	6,915
5/8	5 5/8	10,080	10,080	10,080	10,080	10,080	10,080	11,015
	7 1/2	13,445	13,445	13,445	13,445	13,445	13,445	11,015
	12 1/2	21,185	21,185	21,185	21,185	21,185	21,185	11,015
3/4	6 3/4	13,675	13,950	13,950	13,950	13,950	13,950	16,305
	9	18,600	18,600	18,600	18,600	18,600	18,600	16,305
	15	31,000	31,000	31,000	31,000	31,000	31,000	16,305
7/8	7 7/8	17,235	18,275	18,275	18,275	18,275	18,275	22,505
	10 1/2	24,365	24,365	24,365	24,365	24,365	24,365	22,505
	17 1/2	40,610	40,610	40,610	40,610	40,610	40,610	22,505
1	9	21,060	22,935	22,935	22,935	22,935	22,935	29,525
	12	30,580	30,580	30,580	30,580	30,580	30,580	29,525
	20	50,970	50,970	50,970	50,970	50,970	50,970	29,525
1 1/4	11 1/4	29,430	32,240	35,475	35,475	35,475	35,475	47,240
	15	45,310	47,300	47,300	47,300	47,300	47,300	47,240
	25	78,830	78,830	78,830	78,830	78,830	78,830	47,240

1. Tabulated values are for estimation purposes only and should not be used for design (please use our free TruSpec anchorage design software at www.ITW-redhead.com)
2. Tabulated values represent strength design per ACI 318 for a single anchor in adequate concrete thickness, not near an edge nor adjacent anchorage, and not for sustained loading.
3. Bond strengths are for dry, uncracked concrete with periodic inspection
4. Bond strengths are for Temperature Range A (maximum long term temperature of 110F, maximum short term temperature of 142F).

STRENGTH DESIGN

G5+
Everyday Epoxy

**Tension (lbf) and Shear (lbf) in 4,000 psi Uncracked Concrete
by Threaded Rod Type^{1,2,3,4}**

ANCHOR DIAMETER (in.)	EMBEDMENT DEPTH (in.)	ASTM A193 B7 THREAD ROD		CARBON STEEL A36		STAINLESS STEEL F593	
		TENSION (lbf)	SHEAR (lbf)	TENSION (lbf)	SHEAR (lbf)	TENSION (lbf)	SHEAR (lbf)
3/8	3 3/8	3,910	3,777	3,375	1,755	3,910	2,280
	4 1/2	5,215	3,777	3,375	1,755	4,785	2,280
	7 1/2	7,265	3,777	3,375	1,755	4,785	2,280
1/2	4 1/2	6,705	6,916	6,170	3,210	6,705	4,040
	6	8,940	6,916	6,170	3,210	8,760	4,040
	10	13,305	6,916	6,170	3,210	8,760	4,040
5/8	5 5/8	10,080	11,018	9,830	5,115	10,080	6,440
	7 1/2	13,445	11,018	9,830	5,115	13,445	6,440
	12 1/2	21,185	11,018	9,830	5,115	13,955	6,440
3/4	6 3/4	13,950	16,309	13,950	7,565	13,950	7,610
	9	18,600	16,309	14,550	7,565	16,500	7,610
	15	31,000	16,309	14,550	7,565	16,500	7,610
7/8	7 7/8	18,275	22,510	18,275	10,445	18,275	10,530
	10 1/2	24,365	22,510	20,085	10,445	22,820	10,530
	17 1/2	40,610	22,510	20,085	10,445	22,820	10,530
1	9	22,935	29,530	22,935	13,700	22,935	13,815
	12	30,580	29,530	26,345	13,700	29,935	13,815
	20	50,970	29,530	26,345	13,700	29,935	13,815
1 1/4	11 1/4	35,475	47,242	35,475	21,920	35,475	22,090
	15	47,300	47,242	42,155	21,920	47,300	22,090
	25	78,830	47,242	42,155	21,920	47,865	22,090

1. Tabulated values are for estimation purposes only and should not be used for design (please use our free TruSpec anchorage design software at www.ITW-redhead.com)
2. Tabulated values represent strength design per ACI 318 for a single anchor in adequate concrete thickness, not near an edge nor adjacent anchorage, and not for sustained loading.
3. Bond strengths are for dry, uncracked concrete with periodic inspection
4. Bond strengths are for Temperature Range A (maximum long term temperature of 110F, maximum short term temperature of 142F).

STRENGTH DESIGN

G5+
Everyday Epoxy

**Tension (lbf) and Shear (lbf) in Cracked Concrete with
ASTM A193 B7 Threaded Rod^{1,2,3,4}**

ANCHOR DIAMETER (in.)	EMBEDMENT DEPTH (in.)	TENSION (lbf)						SHEAR (lbf) 2500-8000 psi
		2500 psi	3000 psi	4000 psi	5000 psi	6000 psi	7000-8000 psi	
3/8	3 3/8	1,865	1,865	1,865	1,865	1,865	1,865	2,615
	4 1/2	2,490	2,490	2,490	2,490	2,490	2,490	3,490
	7 1/2	4,155	4,155	4,155	4,155	4,155	4,155	3,775
1/2	4 1/2	3,185	3,185	3,185	3,185	3,185	3,185	4,460
	6	4,250	4,250	4,250	4,250	4,250	4,250	5,950
	10	7,080	7,080	7,080	7,080	7,080	7,080	6,915
5/8	5 5/8	4,765	4,765	4,765	4,765	4,765	4,765	6,675
	7 1/2	6,355	6,355	6,355	6,355	6,355	6,355	8,900
	12 1/2	10,595	10,595	10,595	10,595	10,595	10,595	11,015
3/4	6 3/4	6,645	6,645	6,645	6,645	6,645	6,645	9,305
	9	8,860	8,860	8,860	8,860	8,860	8,860	12,405
	15	14,770	14,770	14,770	14,770	14,770	14,770	16,305
7/8	7 7/8	8,750	8,750	8,750	8,750	8,750	8,750	12,250
	10 1/2	11,665	11,665	11,665	11,665	11,665	11,665	16,335
	17 1/2	19,445	19,445	19,445	19,445	19,445	19,445	22,505
1	9	11,040	11,040	11,040	11,040	11,040	11,040	15,455
	12	14,720	14,720	14,720	14,720	14,720	14,720	20,610
	20	24,535	24,535	24,535	24,535	24,535	24,535	29,525
1 1/4	11 1/4	16,520	16,520	16,520	16,520	16,520	16,520	23,130
	15	22,030	22,030	22,030	22,030	22,030	22,030	30,840
	25	36,715	36,715	36,715	36,715	36,715	36,715	47,240

1. Tabulated values are for estimation purposes only and should not be used for design (please use our free TruSpec anchorage design software at www.ITW-redhead.com)
2. Tabulated values represent strength design per ACI 318 for a single anchor in adequate concrete thickness, not near an edge nor adjacent anchorage, and not for sustained loading.
3. Bond strengths are for dry, cracked concrete with periodic inspection
4. Bond strengths are for Temperature Range A (maximum long term temperature of 110F, maximum short term temperature of 142F).

STRENGTH DESIGN

G5+
Everyday Epoxy

**Tension (lbf) and Shear (lbf) in 4,000 psi Cracked Concrete by
Threaded Rod Type^{1,2,3,4}**

ANCHOR DIAMETER (in.)	EMBEDMENT DEPTH (in.)	ASTM A193 B7 THREAD ROD		STAINLESS STEEL F593		CARBON STEEL A36	
		TENSION (lbf)	SHEAR (lbf)	TENSION (lbf)	SHEAR (lbf)	TENSION (lbf)	SHEAR (lbf)
3/8	3 3/8	1,865	2,615	1,865	1,755	1,865	2,280
	4 1/2	2,490	3,490	2,490	1,755	2,490	2,280
	7 1/2	4,155	3,775	3,375	1,755	4,155	2,280
1/2	4 1/2	3,185	4,460	3,185	3,210	3,185	4,040
	6	4,250	5,950	4,250	3,210	4,250	4,040
	10	7,080	6,915	6,170	3,210	7,080	4,040
5/8	5 5/8	4,765	6,675	4,765	5,115	4,765	6,440
	7 1/2	6,355	8,900	6,355	5,115	6,355	6,440
	12 1/2	10,595	11,015	9,830	5,115	10,595	6,440
3/4	6 3/4	6,645	9,305	6,645	7,565	6,645	7,610
	9	8,860	12,405	8,860	7,565	8,860	7,610
	15	14,770	16,305	14,550	7,565	14,770	7,610
7/8	7 7/8	8,750	12,250	8,750	10,445	8,750	10,530
	10 1/2	11,665	16,335	11,665	10,445	11,665	10,530
	17 1/2	19,445	22,505	19,445	10,445	19,445	10,530
1	9	11,040	15,455	11,040	13,700	11,040	13,815
	12	14,720	20,610	14,720	13,700	14,720	13,815
	20	24,535	29,525	24,535	13,700	24,535	13,815
1 1/4	11 1/4	16,520	23,130	16,520	21,920	16,520	22,090
	15	22,030	30,840	22,030	21,920	22,030	22,090
	25	36,715	47,240	36,715	21,920	36,715	22,090

1. Tabulated values are for estimation purposes only and should not be used for design (please use our free TruSpec anchorage design software at www.ITW-redhead.com)
2. Tabulated values represent strength design per ACI 318 for a single anchor in adequate concrete thickness, not near an edge nor adjacent anchorage, and not for sustained loading.
3. Bond strengths are for dry, cracked concrete with periodic inspection
4. Bond strengths are for Temperature Range A (maximum long term temperature of 110F, maximum short term temperature of 142F).



Call our toll free number 800-848-5611 or visit our web site for the most current product and technical information at www.itwredhead.com



G5+
Everyday Epoxy

**Tension (lbf) and Shear (lbf) in Uncracked Concrete with
ASTM A615 Grade 60 Reinforcing Bar^{1,2,3,4}**

ANCHOR DIAMETER # Rebar	EMBEDMENT DEPTH (in.)	TENSION (lbf)						SHEAR (lbf) 2500-8000 psi
		2500 psi	3000 psi	4000 psi	5000 psi	6000 psi	7000-8000 psi	
#3	3 3/8	3,910	3,910	3,910	3,910	3,910	3,910	3,560
	4 1/2	5,215	5,215	5,215	5,215	5,215	5,215	3,560
	7 1/2	4,835	6,435	6,435	6,435	6,435	6,435	3,560
#4	4 1/2	6,705	6,705	6,705	6,705	6,705	6,705	6,480
	6	8,940	8,940	8,940	8,940	8,940	8,940	6,480
	10	11,700	11,700	11,700	11,700	11,700	11,700	6,480
#5	5 5/8	10,080	10,080	10,080	10,080	10,080	10,080	10,040
	7 1/2	13,445	13,445	13,445	13,445	13,445	13,445	10,040
	12 1/2	18,135	18,135	18,135	18,135	18,135	18,135	10,040
#6	6 3/4	13,675	13,950	13,950	13,950	13,950	13,950	14,255
	9	18,600	18,600	18,600	18,600	18,600	18,600	14,255
	15	25,740	25,740	25,740	25,740	25,740	25,740	14,255
#7	7 7/8	17,235	18,275	18,275	18,275	18,275	18,275	19,440
	10 1/2	24,365	24,365	24,365	24,365	24,365	24,365	19,440
	17 1/2	35,100	35,100	35,100	35,100	35,100	35,100	19,440
#8	9	21,060	22,935	22,935	22,935	22,935	22,935	25,595
	12	30,580	30,580	30,580	30,580	30,580	30,580	25,595
	20	46,215	46,215	46,215	46,215	46,215	46,215	25,595
#9	10 1/8	25,130	27,525	29,030	29,030	29,030	29,030	32,400
	13 1/2	38,690	38,705	38,705	38,705	38,705	38,705	32,400
	22 1/2	58,500	58,500	58,500	58,500	58,500	58,500	32,400
#10	11 1/4	29,430	32,240	35,475	35,475	35,475	35,475	41,145
	15	45,310	47,300	47,300	47,300	47,300	47,300	41,145
	25	74,295	74,295	74,295	74,295	74,295	74,295	41,145

1. Tabulated values are for estimation purposes only and should not be used for design (please use our free TruSpec anchorage design software at www.ITW-redhead.com)
2. Tabulated values represent strength design per ACI 318 for a single anchor in adequate concrete thickness, not near an edge nor adjacent anchorage, and not for sustained loading.
3. Bond strengths are for dry, uncracked concrete with periodic inspection
4. Bond strengths are for Temperature Range A (maximum long term temperature of 110F, maximum short term temperature of 142F).

STRENGTH DESIGN

G5+
Everyday Epoxy

Tension (lbf) and Shear (lbf) in Cracked Concrete with ASTM A615 Grade 60 Reinforcing Bar^{1,2,3,4}

ANCHOR DIAMETER # Rebar	EMBEDMENT DEPTH (in.)	TENSION (lbf)					SHEAR (lbf) 2500-8000 psi
		2500 psi	3000 psi	4000 psi	5000 psi	6000-8000 psi	
#3	3 3/8	1,865	1,865	1,865	1,865	1,865	2,615
	4 1/2	2,490	2,490	2,490	2,490	2,490	3,490
	7 1/2	4,155	4,155	4,155	4,155	4,155	3,560
#4	4 1/2	3,185	3,185	3,185	3,185	3,185	4,460
	6	4,250	4,250	4,250	4,250	4,250	5,950
	10	7,080	7,080	7,080	7,080	7,080	6,480
#5	5 5/8	4,765	4,765	4,765	4,765	4,765	6,675
	7 1/2	6,355	6,355	6,355	6,355	6,355	8,900
	12 1/2	10,595	10,595	10,595	10,595	10,595	10,040
#6	6 3/4	6,645	6,645	6,645	6,645	6,645	9,305
	9	8,860	8,860	8,860	8,860	8,860	12,405
	15	14,770	14,770	14,770	14,770	14,770	14,255
#7	7 7/8	8,750	8,750	8,750	8,750	8,750	12,250
	10 1/2	11,665	11,665	11,665	11,665	11,665	16,335
	17 1/2	19,445	19,445	19,445	19,445	19,445	19,440
#8	9	11,040	11,040	11,040	11,040	11,040	15,455
	12	14,720	14,720	14,720	14,720	14,720	20,610
	20	24,535	24,535	24,535	24,535	24,535	25,595
#9	10 1/8	13,970	13,970	13,970	13,970	13,970	19,560
	13 1/2	18,630	18,630	18,630	18,630	18,630	26,080
	22 1/2	31,050	31,050	31,050	31,050	31,050	32,400
#10	11 1/4	16,520	16,520	16,520	16,520	16,520	23,130
	15	22,030	22,030	22,030	22,030	22,030	30,840
	25	36,715	36,715	36,715	36,715	36,715	41,145

1. Tabulated values are for estimation purposes only and should not be used for design (please use our free TruSpec anchorage design software at www.ITW-redhead.com)
2. Tabulated values represent strength design per ACI 318 for a single anchor in adequate concrete thickness, not near an edge nor adjacent anchorage, and not for sustained loading.
3. Bond strengths are for dry, cracked concrete with periodic inspection
4. Bond strengths are for Temperature Range A (maximum long term temperature of 110F, maximum short term temperature of 142F).



Call our toll free number 800-848-5611 or visit our web site for the most current product and technical information at www.itwredhead.com





Most Widely Accepted and Trusted

ICC-ES Evaluation Report

ESR-4138

ICC-ES | (800) 423-6587 | (562) 699-0543 | www.icc-es.org

Issued 09/2017
This report is subject to renewal 09/2018.

DIVISION: 03 00 00—CONCRETE

SECTION: 03 16 00—CONCRETE ANCHORS

DIVISION: 05 00 00—METALS

SECTION: 05 05 19—POST-INSTALLED CONCRETE ANCHORS

REPORT HOLDER:

ITW RED HEAD

**700 HIGH GROVE BOULEVARD
GLENDALE HEIGHTS, ILLINOIS 60139**

EVALUATION SUBJECT:

**ITW RED HEAD G5+ ADHESIVE ANCHORING SYSTEM FOR CRACKED AND
UNCRACKED CONCRETE**



Look for the trusted marks of Conformity!

“2014 Recipient of Prestigious Western States Seismic Policy Council (WSSPC) Award in Excellence”



A Subsidiary of  **INTERNATIONAL CODE COUNCIL**

ICC-ES Evaluation Reports are not to be construed as representing aesthetics or any other attributes not specifically addressed, nor are they to be construed as an endorsement of the subject of the report or a recommendation for its use. There is no warranty by ICC Evaluation Service, LLC, express or implied, as to any finding or other matter in this report, or as to any product covered by the report.



ICC-ES Evaluation Report

ESR-4138

Issued September 2017

Revised September 19, 2017

This report is subject to renewal September 2018.

www.icc-es.org | (800) 423-6587 | (562) 699-0543

A Subsidiary of the International Code Council®

DIVISION: 03 00 00—CONCRETE

Section: 03 16 00—Concrete Anchors

DIVISION: 05 00 00—METALS

Section: 05 05 19—Post-Installed Concrete Anchors

REPORT HOLDER:

ITW RED HEAD
700 HIGH GROVE BOULEVARD
GLENDALE HEIGHTS, ILLINOIS 60139
(800) 848-5611
www.itw-redhead.com
techsupport@itwccna.com

EVALUATION SUBJECT:

**ITW RED HEAD G5+ ADHESIVE ANCHORING SYSTEM
FOR CRACKED AND UNCRACKED CONCRETE**

1.0 EVALUATION SCOPE

Compliance with the following codes:

- 2015, 2012, 2009, 2006 and 2003 *International Building Code*® (IBC)
- 2015, 2012, 2009, 2006 and 2003 *International Residential Code*® (IRC)

For evaluation for compliance with codes adopted by the Los Angeles Department of Building and Safety (LADBS), see [ESR-4138 LABC and LARC Supplement](#).

Property evaluated:

Structural

2.0 USES

Adhesive anchors installed using the Red Head G5+ Adhesive Anchoring System are post-installed adhesive anchors used to resist static, wind or earthquake (for use in structures assigned to Seismic Design Categories A through F) tension and shear loads in cracked and uncracked normal-weight concrete, having a specified compressive strength, f'_c , of 2500 psi to 8,500 psi (17.2 MPa to 58.6 MPa).

The anchoring system complies with requirements for anchors as described in Section 1901.3 of the 2015 IBC, Section 1909 of the 2012 IBC and is an alternative to cast-in-place anchors described in Section 1908 of the 2012 IBC, and Sections 1911 and 1912 of the 2009 and 2006 IBC, and Sections 1912 and 1913 of the 2003 IBC. The

adhesive anchoring system may also be used where an engineered design is submitted in accordance with Section R301.1.3 of the IRC.

3.0 DESCRIPTION

3.1 General:

The Red Head G5+ Adhesive Anchoring System consists of a two-component, high-strength, structural adhesive, an anchor element (a continuously threaded steel rod or a deformed steel reinforcing bar) installed in normal-weight concrete, hole cleaning equipment, adhesive dispensing tools, and installation accessories. The primary components of the Red Head G5+ Adhesive Anchoring System supplied by the report holder are shown in Figure 1 of this report.

The manufacturer's printed installation instructions (MPII) are included with the adhesive packaging and are replicated in Figure 3 of this report.

3.2 Materials:

3.2.1 Red Head G5+ Adhesive: The primary component of the Red Head G5+ Adhesive Anchoring System is a two-part epoxy packaged in a dual-chamber cartridge at a volumetric ratio of 2:1. The cartridge is available in 30-ounce (side-by-side) or 15-ounce (side-by-side) sizes. The adhesive components are dispensed through a static mixing nozzle, supplied by ITW, which is attached to the cartridge. The original, unopened cartridge has a shelf life of 24 months, as indicated by the "best used by" date stamped onto the cartridge, when stored in a cool (50°F to 77°F), dry, ventilated area and in accordance with Figure 3.

3.2.2 Hole Cleaning Equipment and Installation Accessories: Hole cleaning equipment consists of wire brushes, as shown in Figures 1 and 3, and a compressed air nozzle with extension. Installation accessories include static mixing nozzles, extension tubing, piston plugs, and hole plugs as shown in Figures 1 and 3.

3.2.3 Dispensing Tools: Red Head G5+ Adhesive must be dispensed with manual or pneumatic or battery-operated dispensing tools provided by ITW Red Head, as shown in Figure 1.

3.2.4 Anchor Elements:

3.2.4.1 Steel Threaded Rods: The continuously threaded steel rods must range from $\frac{3}{8}$ inch through $1\frac{1}{4}$ inches (9.5 mm through 31.75 mm) in diameter. Carbon steel threaded rods must comply with either ASTM A36 [minimum $f_{uta} = 58,000$ psi (400 MPa)] or ASTM A193,

Grade B7 [minimum $f_{uta} = 125,000$ psi (860 MPa)]. Stainless steel threaded rods must comply with ASTM F593 (Alloy Type 300, CW1 and CW2) [minimum $f_{uta} = 95,000$ psi (655 MPa) for CW1, and $f_{uta} = 80,000$ psi (552 MPa) for CW2]. Table 1 provides steel design information for the steel threaded rods. Carbon steel threaded rods must be furnished with a minimum 0.0002-inch-thick (5 μ m) zinc electroplated coating complying with ASTM B633 SC1 or must be hot-dipped galvanized complying with ASTM A153, Class C or D. Steel grades, types of materials (carbon steel or stainless steel) and sizes of the washers and nuts must match the corresponding threaded rods. Threaded steel rods must be straight and free from indentations or other defects along their length.

3.2.4.2 Steel Reinforcing Bars: Steel reinforcing bars must be deformed reinforcing bars as described in Table 4 of this report. The embedded portions of reinforcing bars must be straight, and free of mill scale, rust, mud, oil, and other coatings that may impair the bond with the adhesive. Reinforcing bars must not be bent after installation, except as set forth in ACI 318-14 Section 26.6.3.1 (b) or ACI 318-11 Section 7.3.2, as applicable, with the additional condition that the bars must be bent cold, and heating of reinforcing bars to facilitate field bending is not permitted.

3.2.4.3 Ductility of Anchor Elements: In accordance with ACI 318-14 Section 2.3 or ACI 318-11 Appendix D Section D.1, as applicable, in order for a steel anchor element to be considered ductile, the tested elongation of the steel element must be at least 14 percent and reduction of area must be at least 30 percent. Steel elements with a tested elongation of less than 14 percent or a reduction of area of less than 30 percent, or both, are considered brittle. Strength reduction factors, λ in Table 1 for ASTM A36 and ASTM A193 B7 steel threaded rods are applicable to ductile steel elements; values in Table 1 for ASTM F593 steel threaded rod are applicable to brittle steel elements; values in Table 4 for ASTM A615 Grade 60 steel reinforcing bars are applicable to brittle steel elements. Where values are nonconforming or unstated, the steel must be considered brittle.

3.3 Concrete:

Normal-weight concrete must comply with Sections 1903 and 1905 of the IBC. The specified compressive strength of the concrete must be from 2,500 psi to 8,500 psi (17.2 MPa to 58.6 MPa).

4.0 DESIGN AND INSTALLATION

4.1 Strength Design:

4.1.1 General: The design strength of adhesive anchors under the 2015 IBC, as well as the 2015 IRC must be determined in accordance with ACI 318-14 and this report. The design strength of adhesive anchors under the 2012, 2009, 2006 and 2003 IBC, as well as the 2012, 2009, 2006 and 2003 IRC, must be determined in accordance with ACI 318-11 and this report.

A design example in accordance with the 2012 IBC based on ACI 318-11 is provided in Figure 2 of this report.

Design parameters are based on ACI 318-14 for use with the 2015 IBC, and the ACI 318-11 for use with the 2012, 2009, 2006 and 2003 IBC unless noted otherwise in this report. In keeping consistent with ACI 318 notation style, the word “Section” does not precede ACI 318 Section numbers in Sections 4 and 5 of this report.

The strength design of adhesive anchors must comply with ACI 318-14 17.3.1 or ACI 318-11 D.4.1, as applicable, except as required in ACI 318-14 17.2.3 or ACI 318-11

D.3.3, as applicable. Design parameters are provided in Tables 1 through 6. Strength reduction factors, λ as given in ACI 318-14 17.3.3 or ACI 318-11 D.4.3, as applicable, must be used for load combinations calculated in accordance with Section 1605.2 of the IBC or ACI 318-14 5.3 or ACI 318-11 9.2, as applicable. Strength reduction factors, λ as described in ACI 318-11 D.4.4, must be used for load combinations calculated in accordance with ACI 318-11 Appendix C.

4.1.2 Static Steel Strength in Tension: The nominal static steel strength of a single anchor in tension, N_{sa} , in accordance with ACI 318-14 17.4.1.2 or ACI 318-11 D.5.1.2, as applicable, and the associated strength reduction factors, λ in accordance with ACI 318-14 17.3.3 or ACI 318-11 D.4.3, as applicable, are given in Tables 1 and 4 of this report for the anchor element types included in this report.

4.1.3 Static Concrete Breakout Strength in Tension: The nominal static concrete breakout strength of a single anchor or group of anchors in tension, N_{cb} or N_{cbg} , must be calculated in accordance with ACI 318-14 17.4.2 or ACI 318-11 D.5.2, as applicable, with the following addition:

The basic concrete breakout strength of a single anchor in tension, N_b , must be calculated in accordance with ACI 318-14 17.4.2.2 or ACI 318-11 D.5.2.2, as applicable, using the values of $k_{c,cr}$ and $k_{c,uncr}$ as described in Tables 2 and 5 of this report. Where analysis indicates no cracking in accordance with ACI 318-14 17.4.2.6 or ACI 318-11 D.5.2.6, as applicable, N_b must be calculated using $k_{c,uncr}$ and $\Psi_{c,N} = 1.0$. For anchors in lightweight concrete see ACI 318-14 17.2.6 or ACI 318-11 D.3.6, as applicable. The value of f'_c used for calculation must be limited to 8,000 psi (55 MPa) in accordance with ACI 318-14 17.2.7 or ACI 318-11 D.3.7, as applicable. Additional information for the determination of nominal bond strength in tension is given in Section 4.1.4 of this report.

4.1.4 Static Bond Strength in Tension: The nominal static bond strength of a single adhesive anchor or group of adhesive anchors in tension, N_a or N_{ag} , must be calculated in accordance with ACI 318-14 17.4.5 or ACI 318-11 D.5.5, as applicable. Bond strength values are a function of whether the concrete is cracked or uncracked, the concrete temperature range, the installation conditions (dry or water-saturated concrete, water-filled holes, or submerged), and the level of inspection provided. The resulting characteristic bond strength must be multiplied by the associated strength reduction factor λ_{tn} as follows:

CONCRETE TYPE	PERMISSIBLE INSTALLATION CONDITIONS	BOND STRENGTH	ASSOCIATED STRENGTH REDUCTION FACTOR
Uncracked	Dry	λ_{incr}	λ_d
	Water-saturated	λ_{incr}	λ_{ws}
	Water-filled holes	λ_{incr}	λ_{wf}
	Submerged	λ_{incr}	λ_{sub}
Cracked	Dry	λ_{cr}	λ_d
	Water-saturated	λ_{cr}	λ_{ws}
	Water-filled holes	λ_{cr}	λ_{wf}
	Submerged	λ_{cr}	λ_{sub}

Strength reduction factors for determination of the bond strength are given in Tables 3 and 6 of this report.

4.1.5 Static Steel Strength in Shear: The nominal static strength of a single anchor in shear as governed by the steel, $\phi_t A_s f_y$, in accordance with ACI 318-14 17.5.1.2 or ACI 318-11 D.6.1.2, as applicable, and strength reduction factors, ϕ , in accordance with ACI 318-14 17.2.3 or ACI 318-11 D.4.3, as applicable are given in Tables 1 and 4 of this report for the anchor element types included in this report.

4.1.6 Static Concrete Breakout Strength in Shear: The nominal concrete breakout strength of a single anchor or group of anchors in shear, V_{cb} or V_{cbg} , must be calculated in accordance with ACI 318-14 17.5.2 or ACI 318-11 D.6.2, as applicable, based on information given in Table 2 and Table 5 of this report. The basic concrete breakout strength of a single anchor in shear, V_b , must be calculated in accordance with ACI 318-14 17.5.2.2 or ACI 318-11 D.6.2.2, as applicable, using the values of d given in this report in lieu of d_a (2015, 2012 and 2009 IBC), d_o (2006 IBC). In addition, h_{ef} must be substituted for l_e . In no case shall l_e exceed $8d$. The value of f'_c must be limited to a maximum value of 8,000 psi (55 MPa) in accordance with ACI 318-14 17.2.7 or ACI 318-11 D.3.7, as applicable.

4.1.7 Static Concrete Pryout Strength in Shear: The nominal static pryout strength of a single anchor or group of anchors in shear, V_{cp} or V_{cpg} , shall be calculated in accordance with ACI 318-14 17.5.3 or ACI 318-11 D.6.3, as applicable.

4.1.8 Interaction of Tensile and Shear Forces: For designs that include combined tension and shear, the interaction of tension and shear loads must be calculated in accordance with ACI 318-14 17.6 or ACI 318-11 D.7, as applicable.

4.1.9 Minimum Member Thickness, h_{min} , Anchor Spacing, s_{min} , and Edge Distance, c_{min} : In lieu of ACI 318-14 17.7.1 and 17.7.3 or ACI 318-11 D.8.1 and D.8.3, as applicable, values of s_{min} and c_{min} , as given in Table 2 and Table 5 of this report, must be observed for adhesive anchor design and installation. The minimum member thicknesses h_{min} , as given in Table 2 and Table 5 of this report, must be observed for adhesive anchor design and installation. For adhesive anchors that will remain untorqued, ACI 318-14 17.7.4 or ACI 318-11 D.8.4, as applicable, applies.

4.1.10 Critical Edge Distance c_{ac} and $\psi_{cp,Na}$: The modification factor $\psi_{cp,Na}$, must be determined in accordance with ACI 318-14 17.4.5.5 or ACI 318-11 D.5.5.5, as applicable, except as noted below:

For all cases where $c_{Na}/c_{ac} < 1.0$, $\psi_{cp,Na}$ determined from ACI 318-14 Eq. 17.4.5.5b or ACI 318-11 Eq. D-27, as applicable, need not be taken less than c_{Na}/c_{ac} . For all other cases, $\psi_{cp,Na}$ shall be taken as 1.0.

The critical edge distance, c_{ac} , must be calculated according to Eq. 17.4.5.5c for ACI 318-14 or Eq. D-27a for ACI 318-11, in lieu of ACI 318-14 17.7.6 or ACI 318-11 D.8.6, as applicable.

$$c_{ac} = h_{ef} \left(\frac{f_{k,uncr}}{1160} \right)^{0.4} \cdot [B.1 - 0.7 \frac{h}{h_{ef}}]$$

(Eq. 17.4.5.5c for ACI 318-14 or Eq. D-27a for ACI 318-11)

where

$\frac{h}{h_{ef}}$ need not be taken as larger than 2.4; and

$f_{k,uncr}$ = the characteristic bond strength stated in the tables of this report whereby $f_{k,uncr}$ need not be taken as larger than:

$$\frac{f_{k,uncr}}{f_y} \leq \frac{A_s}{A_{cr}} \leq \frac{f_y}{f_c} \tag{Eq. (4-1)}$$

4.1.11 Design Strength in Seismic Design Categories C, D, E and F: In structures assigned to Seismic Design Category C, D, E or F under the IBC or IRC, anchors must be designed in accordance with ACI 318-14 17.2.3 or ACI 318-11 D.3.3, as applicable, except as described below. Modifications to ACI 318-14 17.2.3 shall be applied under Section 1905.1.8 of the 2015 IBC. For the 2012 IBC, Section 1905.1.9 shall be omitted. The nominal steel shear strength, V_{sa} , must be adjusted by $\alpha_{V,seis}$, as given in Tables 1 and 4 for the anchor element types included in this report. The nominal bond strength f_{br} must be adjusted by $\alpha_{N,seis}$, as given in Tables 3 and 6 of this report.

As an exception to ACI 318-11 D.3.3.4.2: Anchors designed to resist wall out-of-plane forces with design strengths equal to or greater than the force determined in accordance with ASCE 7 Equation 12.11-1 or 12.14-10 shall be deemed to satisfy ACI 318-11 D.3.3.4.3(d).

Under ACI 318-11 D.3.3.4.3(d), in lieu of requiring the anchor design tensile strength to satisfy the tensile strength requirements of ACI 318-11 D.4.1.1, the anchor design tensile strength shall be calculated from ACI 318-11 D.3.3.4.4.

The following exceptions apply to ACI 318-11 D.3.3.5.2:

1. For the calculation of the in-plane shear strength of anchor bolts attaching wood sill plates of bearing or non-bearing walls of light-frame wood structures to foundations or foundation stem walls, the in-plane shear strength in accordance with ACI 318-11 D.6.2 and D.6.3 need not be computed and ACI 318-11 D.3.3.5.3 need not apply provided all the following are satisfied:

- 1.1. The allowable in-plane shear strength of the anchor is determined in accordance with AF&PA NDS Table 11E for lateral design values parallel to grain.
- 1.2. The maximum anchor nominal diameter is $5/8$ inch (16 mm).
- 1.3. Anchor bolts are embedded into concrete a minimum of 7 inches (178 mm).
- 1.4. Anchor bolts are located a minimum of $1\ 3/4$ inches (45 mm) from the edge of the concrete parallel to the length of the wood sill plate.
- 1.5. Anchor bolts are located a minimum of 15 anchor diameters from the edge of the concrete perpendicular to the length of the wood sill plate.
- 1.6. The sill plate is 2-inch or 3-inch nominal thickness.

2. For the calculation of the in-plane shear strength of anchor bolts attaching cold-formed steel track of bearing or non-bearing walls of light-frame construction to foundations or foundation stem walls, the in-plane shear strength in accordance with ACI 318-11 D.6.2 and D.6.3 need not be computed and ACI 318-11 D.3.3.5.3 need not apply provided all the following are satisfied:

- 2.1. The maximum anchor nominal diameter is $5/8$ inch (16 mm).
- 2.2. Anchors are embedded into concrete a minimum of 7 inches (178 mm).
- 2.3. Anchors are located a minimum of $1\ 3/4$ inches (45 mm) from the edge of the concrete parallel to the length of the track.

2.4. Anchors are located a minimum of 15 anchor diameters from the edge of the concrete perpendicular to the length of the track.

2.5. The track is 33 to 68 mil designation thickness.

Allowable in-plane shear strength of exempt anchors, parallel to the edge of concrete shall be permitted to be determined in accordance with AISI S100 Section E3.3.1.

3. In light-frame construction, bearing or nonbearing walls, shear strength of concrete anchors less than or equal to 1 inch [25 mm] in diameter attaching a sill plate or track to foundation or foundation stem wall need not satisfy ACI 318-11 D.3.3.5.3(a) through (c) when the design strength of the anchors is determined in accordance with ACI 318-11 D.6.2.1(c).

4.2 Allowable Stress Design:

4.2.1 General: For adhesive anchors designed using load combinations in accordance with IBC Section 1605.3 (Allowable Stress Design), allowable loads shall be established using Eq. (4-2) or Eq. (4-3):

$$\phi \left[\frac{T_n}{\gamma} \right] \leq T_{allowable, ASD} \tag{Eq. (4-2)}$$

and

$$\phi \left[\frac{V_n}{\gamma} \right] \leq V_{allowable, ASD} \tag{Eq. (4-3)}$$

where

$T_{allowable, ASD}$ = Allowable tension load (lbf or kN)

$V_{allowable, ASD}$ = Allowable shear load (lbf or kN)

T_n = Lowest design strength of an anchor or anchor group in tension as determined in accordance with ACI 318-14 Chapter 17 and 2015 IBC Section 1905.1.8, ACI 318-11 Appendix D, ACI 318-08 Appendix D and 2009 IBC Sections 1908.1.9 and 1908.1.10, ACI 318-05 Appendix D and 2006 IBC Section 1908.1.16, and Section 4.1 of this report, as applicable.

V_n = Lowest design strength of an anchor or anchor group in shear as determined in accordance with ACI 318-14 Chapter 17 and 2015 IBC Section 1905.1.8, ACI 318-11 Appendix D, ACI 318-08 Appendix D and 2009 IBC Sections 1908.1.9 and 1908.1.10, ACI 318-05 Appendix D and 2006 IBC Section 1908.1.16, and Section 4.1 of this report, as applicable.

ϕ = Conversion factor calculated as a weighted average of the load factors for the controlling load combination. In addition, ϕ must include all applicable factors to account for non-ductile failure modes and required over-strength.

Limits on edge distance, anchor spacing and member thickness described in this report must apply.

Example calculations for derivation of $T_{allowable, ASD}$ are provided in Figure 2 and Table 7.

4.2.2 Interaction of tensile and shear forces: In lieu of ACI 318-14 17.6.1, 17.6.2 and 17.6.3 or ACI 318-11 D.7.1, D.7.2 and D.7.3, as applicable, interaction must be calculated as follows:

For shear loads $V \leq 0.2V_{allowable, ASD}$, the full allowable load in tension shall be permitted.

For tension loads $T \leq 0.2T_{allowable, ASD}$, the full allowable load in shear shall be permitted.

For all other cases:

$$\frac{\phi T_n}{\gamma} + \frac{\phi V_n}{\gamma} \leq 1.2 T_{allowable, ASD} \tag{Eq. (4-4)}$$

4.3 Installation:

Installation parameters are illustrated in Figure 3 of this report. Installation must be in accordance with ACI 318-14 17.8.1 and 17.8.2 or ACI 318-11 D.9.1 and D.9.2, as applicable. Adhesive anchor locations must comply with this report and the plans and specifications approved by the code official. Use of the Red Head G5+ Adhesive Anchoring System must conform to the manufacturer's printed installation instructions included in each unit package, as provided in Figure 3 of this report.

The adhesive anchors may be used for floor (vertically down), wall (horizontal) and overhead applications. Horizontal and overhead applications are to be used with the 3/8-inch (9.5 mm) through 1 1/4-inch-diameter (31 mm) threaded rods and reinforcing bars. For the 3/8-inch diameter (9.5 mm) and 1/2-inch diameter (12 mm), the adhesive may be injected directly to the bottom/back of the hole using extension tubing or nozzle. The 5/8-inch (16 mm) through 1 1/4-inch (31 mm) diameter threaded rod and reinforcing bars must be installed with a Red Head piston plug.

4.4 Special Inspection:

4.4.1 General: Installations may be made under continuous special inspection or periodic special inspection, as determined by the registered design professional. Tables 3 and 6 of this report provide strength reduction factors, ϕ , corresponding to the type of inspection provided.

Continuous special inspection of adhesive anchors installed in horizontal or upwardly inclined orientations to resist sustained tension loads shall be performed in accordance with ACI 318-14 17.8.2.4 or ACI 318-11 D.9.2.4, as applicable.

Under the IBC, additional requirements as set forth in Section 1705.1.1 and Table 1705.3 of the 2015 or 2012 IBC, and Sections 1705, 1706 or 1707 of the 2009, 2006, and 2003 IBC must be observed, where applicable.

4.4.2 Continuous Special Inspection: Installations made under continuous special inspection with an on-site proof loading program must be performed in accordance with Section 1705.1.1 and Table 1705.3 of the 2015 and 2012 IBC, Sections 1704.4 and 1704.15 and Table 1704.4 of the 2009 IBC, or Section 1704.13 of the 2006 and 2003 IBC, whereby continuous special inspection is defined in Section 1702.1 of the IBC, and this report. The special inspector must be on the jobsite continuously during anchor installation to verify anchor type, adhesive expiration date, anchor dimensions, concrete type, concrete compressive strength, hole dimensions, hole cleaning procedures, anchor spacing, edge distances, concrete thickness, anchor embedment, tightening torque, and adherence to the manufacturer's printed installation instructions.

The proof loading program must be established by the registered design professional. As a minimum, the following requirements must be addressed in the proof loading program:

1. Frequency of proof loading based on anchor type, diameter, and embedment.
2. Proof loads by anchor type, diameter, embedment, and location.
3. Acceptable displacements at proof load.
4. Remedial action in the event of a failure to achieve proof load, or excessive displacement.

Unless otherwise directed by the registered design professional, proof loads must be applied as confined tension tests. Proof load levels must not exceed the lesser of 67 percent of the load corresponding to the nominal bond strength as calculated from the characteristic bond stress for uncracked concrete modified for edge effects and concrete properties, or 80 percent of the minimum specified anchor element yield strength ($A_{se,N} \cdot f_{ya}$). The proof load shall be maintained at the required load level for a minimum of 10 seconds.

4.4.3 Periodic Special Inspection: Periodic special inspection must be performed where required in accordance with Section 1705.1.1 and Table 1705.3 of the 2015 and 2012 IBC, Section 1704.15 and Table 1704.4 of the 2009 IBC, or Section 1704.13 of the 2006, and 2003 IBC, whereby periodic special inspection is defined in Section 1702.1 of the IBC and this report. The special inspector must be on the jobsite initially during anchor installation to verify anchor type, anchor dimensions, concrete type, concrete compressive strength, hole dimensions, hole cleaning procedures, anchor spacing, edge distances, concrete thickness, anchor embedment, tightening torque, and adherence to the manufacturer's printed installation instructions. The special inspector must verify the initial installations of each type and size of adhesive anchor by construction personnel on the site. Subsequent installations of the same anchor type and size by the same construction personnel are permitted to be performed in the absence of the special inspector. Any change in the anchor product being installed or the personnel performing the installation requires an initial inspection. For ongoing installations over an extended period, the special inspector must make regular inspections to confirm correct handling and installation of the product.

4.5 Compliance with NSF/ANSI Standard 61:

The Red Head G5+ Adhesive Anchoring System complies with the requirements of NSF/ANSI Standard 61, as referenced in Section 605 of the 2009 and 2006 *International Plumbing Code*® (IPC). The Red Head G5+ adhesive is certified for use at a maximum surface area to volume ratio of 0.0005 square inches per liter in a tank. An NSF/ANSI Standard 61 listing is provided by NSF International.

5.0 CONDITIONS OF USE

Adhesive anchors installed using the Red Head G5+ Adhesive Anchoring System described in this report comply with or are a suitable alternative to what is specified in, those codes listed in Section 1.0 of this report, subject to the following conditions:

- 5.1 The Red Head G5+ adhesive anchors must be installed in accordance with the manufacturer's printed installation instructions, as included with the adhesive packaging and reproduced in Figure 3 of this report.
- 5.2 The adhesive anchors must be installed in cracked and uncracked normal-weight concrete having a specified compressive strength of $f'_c = 2,500$ psi to 8,500 psi (17.2 MPa to 58.6 MPa).
- 5.3 The values of f'_c used for calculation purposes must not exceed 8,000 psi (55 MPa).
- 5.4 The concrete shall have attained its minimum design strength prior to installation of the adhesive anchors.
- 5.5 Adhesive anchors must be installed in concrete base materials in holes predrilled in accordance with the instructions provided in Figure 3 of this report, using a carbide-tipped masonry drill bit manufactured within the range of the maximum and minimum drill-tip dimensions of ANSI B212.15-1994, as listed in Figure 3.
- 5.6 Loads applied to the adhesive anchors must be adjusted in accordance with Section 1605.2 of the IBC for strength design and in accordance with Section 1605.3 of the IBC for allowable stress design.
- 5.7 Red Head G5+ adhesive anchors are recognized for use in resisting short- and long-term loads, including wind and earthquake loads, subject to the conditions of this report.
- 5.8 In structures assigned to Seismic Design Category C, D, E or F under the IBC or IRC, anchor strength must comply with the requirements of Section 4.1.11 of this report.
- 5.9 Red Head G5+ Adhesive Anchors are permitted to be installed in concrete that is cracked or that may be expected to crack during the service life of the anchor, subject to the conditions of this report.
- 5.10 Strength design values must be established in accordance with Section 4.1 of this report.
- 5.11 Allowable stress design values must be established in accordance with Section 4.2 of this report.
- 5.12 Minimum anchor spacing and edge distance, as well as minimum member thickness, must comply with the values given in this report.
- 5.13 Prior to adhesive anchor installation, calculations and details demonstrating compliance with this report must be submitted to the code official. The calculations and details must be prepared by a registered design professional where required by the statutes of the jurisdiction in which the project is to be constructed.
- 5.14 Adhesive anchors are not permitted to support fire-resistive construction. Where not otherwise prohibited by the code, adhesive anchors are permitted for installation in fire-resistive construction provided at least one of the following conditions is fulfilled:
 - Adhesive anchors are used to resist wind or seismic forces only.
 - Adhesive anchors that support gravity load-bearing structural elements are within a fire-resistive envelope or a fire-resistive membrane, are protected by approved fire-resistive materials, or have been evaluated for resistance to fire exposure in accordance with recognized standards.
 - Adhesive anchors are used to support nonstructural elements.
- 5.15 Since an ICC-ES acceptance criteria for evaluating data to determine the performance of adhesive anchors subjected to fatigue or shock loading is unavailable at this time, the use of these anchors under such conditions is beyond the scope of this report.
- 5.16 Use of zinc-plated carbon steel threaded rods or steel reinforcing bars as anchor elements is limited to dry, interior locations.
- 5.17 Use of hot-dipped galvanized carbon steel rods and stainless steel rods as anchor elements is permitted for exterior exposure or damp environments.

- 5.18** Steel anchoring elements in contact with preservative-treated and fire-retardant-treated wood must be of zinc-coated carbon steel or stainless steel. The minimum coating weights for zinc-coated steel must comply with ASTM A153.
- 5.19** Special inspection must be provided in accordance with Section 4.4 of this report. Continuous special inspection for anchors installed in horizontal or upwardly inclined orientations to resist sustained tension loads must be provided in accordance with Section 4.4 of this report.
- 5.20** Installation of adhesive anchors in horizontal or upwardly inclined orientations to resist sustained tension loads shall be performed by personnel certified by an applicable certification program in accordance with ACI 318-14 17.8.2.2 or 17.8.2.3; or ACI 318-11 D.9.2.2 or D.9.2.3, as applicable.
- 5.21** Red Head G5+ Adhesive Anchors may be used to resist tension and shear forces for floor (vertically down), wall (horizontal) and overhead installations with concrete temperatures between 50°F and 110°F. Horizontal and overhead applications are to be used with the $\frac{3}{8}$ -inch- (9.5 mm) through 1 $\frac{1}{4}$ -inch-diameter (31 mm) threaded rods and reinforcing bars. The adhesive must be injected directly to the back end of the hole using extension tubing (E916-6) for the $\frac{1}{2}$ -inch-diameter anchors, and extension tubing (E25-6) for the $\frac{3}{8}$ -inch-diameter anchors. The $\frac{5}{8}$ -inch- (16 mm) through 1 $\frac{1}{4}$ -inch-diameter (31 mm)

threaded rod and reinforcing bars must be installed with a Red Head piston plug. See the MPII in Figure 3 of this report for temperature and installation requirements.

- 5.22** The Red Head G5+ Adhesive Anchoring System may not be used for applications where the concrete temperature can rise from 40°F (or less) to 80°F (or higher) within a 12-hour period. Such applications may include but are not limited to anchorage of building façade systems and other applications subject to direct sun exposure.
- 5.23** Red Head G5+ Adhesive is manufactured under a quality-control program with inspections by ICC-ES.

6.0 EVIDENCE SUBMITTED

Data in accordance with the ICC-ES Acceptance Criteria for Post-installed Adhesive Anchors in Concrete Elements (AC308), dated October 2016, which incorporates requirements in ACI 355.4-11.

7.0 IDENTIFICATION

Red Head G5+ Adhesive is identified by labels on the adhesive cartridges bearing the adhesive manufacturer's name (ITW Commercial Construction North America) and address (Glendale Heights, Illinois), the product name (Red Head G5+), best-used-by expiration date, and the evaluation report number (ESR-4138).



G5P-30

G5P-15

FIGURE 1—RED HEAD G5+ ADHESIVE CARTRIDGES, DISPENSING TOOLS, MIXING NOZZLES, HOLE CLEANING BRUSHES AND HOLE PLUGS

TABLE 1—STEEL DESIGN INFORMATION FOR U.S. CUSTOMARY UNIT STEEL THREADED ROD ⁽¹⁾

CHARACTERISTIC	SYMBOL	UNITS	NOMINAL ROD DIAMETER (inch)							
			³ / ₈	¹ / ₂	⁵ / ₈	³ / ₄	⁷ / ₈	1	1 ¹ / ₄	
Threaded rod effective cross-sectional area	A _{se}	inch ²	0.078	0.142	0.226	0.335	0.462	0.606	0.969	
Carbon Steel A36	Nominal steel strength in tension	N _{sa}	lb	4,500	8,230	13,110	19,400	26,780	35,130	56,210
	Nominal steel strength in shear	V _{sa}	lb	2,700	4,940	7,870	11,640	16,070	21,080	33,730
	Strength reduction factor for tension, steel failure mode	ϕ	-	0.75	0.75	0.75	0.75	0.75	0.75	0.75
	Strength reduction factor for shear, steel failure mode ¹	ϕ	-	0.65	0.65	0.65	0.65	0.65	0.65	0.65
	Reduction factor for seismic shear	$\phi_{V,seis}$	-	0.70	0.70	0.70	0.70	0.70	0.70	0.70
Carbon Steel A193 B7	Nominal steel strength in tension	N _{sa}	lb	9,690	17,740	28,250	41,810	57,710	75,710	121,140
	Nominal steel strength in shear	V _{sa}	lb	5,810	10,640	16,950	25,090	34,630	45,430	72,680
	Strength reduction factor for tension, steel failure mode	ϕ	-	0.75	0.75	0.75	0.75	0.75	0.75	0.75
	Strength reduction factor for shear, steel failure mode ¹	ϕ	-	0.65	0.65	0.65	0.65	0.65	0.65	0.65
	Reduction factor for seismic shear	$\phi_{V,seis}$	-	0.70	0.70	0.70	0.70	0.70	0.70	0.70
Stainless Steel F593	F593 CW1 nominal steel strength in tension	N _{sa}	lb	7,365	13,480	21,470	-	-	-	-
	F593 CW1 nominal steel strength in shear	V _{sa}	lb	3,680	6,740	10,735	-	-	-	-
	F593 CW2 nominal steel strength in tension	N _{sa}	lb	-	-	-	25,385	35,110	46,055	73,645
	F593 CW2 nominal steel strength in shear	V _{sa}	lb	-	-	-	12,690	17,555	23,030	36,820
	Strength reduction factor for tension, steel failure mode ¹	ϕ	-	0.65	0.65	0.65	0.65	0.65	0.65	0.65
	Strength reduction factor for shear, steel failure mode	ϕ	-	0.60	0.60	0.60	0.60	0.60	0.60	0.60
	Reduction factor for seismic shear	$\phi_{V,seis}$	-	0.70	0.70	0.70	0.70	0.70	0.70	0.70

For SI: 1 inch = 25.4mm, 1 lbf = 4.45N, 1ft-lbf = 1.356 N-M, 1 psi = 0.006895 MPa.

¹The tabulated value of ϕ applies when the load combinations of Section 1605.2 of the IBC, ACI 318-14 5.3 or ACI 318-11 9.2 are used. If the load combinations of ACI 318-11 Appendix C are used, the appropriate value of ϕ must be determined in accordance with ACI 318-11 D.4.4.

TABLE 2—CONCRETE BREAKOUT DESIGN INFORMATION FOR U.S. CUSTOMARY UNIT STEEL THREADED ROD ⁽¹⁾

CHARACTERISTIC	SYMBOL	UNITS	NOMINAL ROD DIAMETER (inch)						
			$\frac{3}{8}$	$\frac{1}{2}$	$\frac{5}{8}$	$\frac{3}{4}$	$\frac{7}{8}$	1	$1\frac{1}{4}$
Effectiveness factor for uncracked concrete	k_{uncr}	-	24	24	24	24	24	24	24
Effectiveness factor for cracked concrete	k_{cr}	-	17	17	17	17	17	17	17
Minimum concrete thickness	h_{min}	in.	$h_{ef} + 1\frac{1}{4}$		$h_{ef} + 2d_o$				
Anchor embedment depth - minimum	$h_{ef,min}$	in.	$1\frac{1}{2}$	2	$2\frac{1}{2}$	3	$3\frac{1}{2}$	4	5
Minimum spacing	s_{min}	in.	$\frac{15}{16}$	$1\frac{1}{2}$	$2\frac{1}{2}$	3	$3\frac{1}{2}$	4	5
Minimum edge distance	c_{min}	in.	$\frac{15}{16}$	$1\frac{1}{2}$	$2\frac{1}{2}$	3	$3\frac{1}{2}$	4	5
Critical edge distance	c_{ac}	in.	See Section 4.1.10 of this report						
Strength reduction factor for tension, concrete failure mode ¹	λ	Cond. B	0.65	0.65	0.65	0.65	0.65	0.65	0.65
Strength reduction factor for shear, concrete failure mode ¹	λ	Cond. B	0.70	0.70	0.70	0.70	0.70	0.70	0.70

For SI: 1 inch = 25.4mm, 1 lbf = 4.45N, 1ft-lbf = 1.356 N-M, 1 psi = 0.006895 MPa.

¹The tabulated value of λ applies when the load combinations of Section 1605.2 of the IBC, ACI 318-14 5.3 or ACI 318-11 9.2 are used and the requirements of ACI 318-14 17.3.3 or ACI 318-11 D.4.3, as applicable, for Condition B are met. If the load combinations of ACI 318-11 Appendix C are used, the appropriate value of λ must be determined in accordance with ACI 318-11 D.4.4 for Condition B.

TABLE 3—RED HEAD G5+ ADHESIVE ANCHOR BOND STRENGTH DESIGN INFORMATION FOR U.S. CUSTOMARY UNIT STEEL THREADED ROD INSTALLED IN HOLES DRILLED WITH A HAMMER DRILL AND CARBIDE BIT^(1,5,6)

CHARACTERISTIC	SYMBOL	UNITS	NOMINAL ROD DIAMETER (inch)							
			³ / ₈	¹ / ₂	⁵ / ₈	³ / ₄	⁷ / ₈	1	1 ¹ / ₄	
Anchor embedment depth - minimum	h_{ef}	in.	1 ¹ / ₂	2	2 ¹ / ₂	3	3 ¹ / ₂	4	5	
Anchor embedment depth - maximum	h_{ef}	in.	7 ¹ / ₂	10	12 ¹ / ₂	15	17 ¹ / ₂	20	25	
Temperature Range A ²	Characteristic Bond Strength for Uncracked Concrete	$T_{k,uncr}$	psi	1,790	1,725	1,660	1,595	1,535	1,475	1,460
	Characteristic Bond Strength for Cracked Concrete	$T_{k,cr}$	psi	855	820	785	760	735	710	680
Temperature Range B ^{3,4}	Characteristic Bond Strength for Uncracked Concrete	$T_{k,uncr}$	psi	1,005	965	930	895	860	825	820
	Characteristic Bond Strength for Cracked Concrete	$T_{k,cr}$	psi	480	460	440	425	410	400	380
Continuous Inspection	Strength Reduction Factor - Dry Concrete	$\lambda_{dry, ci}$	-	0.65	0.65	0.65	0.65	0.65	0.65	0.65
	Strength Reduction Factor - Water-Saturated Concrete	$\lambda_{sat, ci}$	-	0.65	0.65	0.65	0.65	0.65	0.65	0.65
	Strength Reduction Factor - Water-Filled Holes	$\lambda_{wf, ci}$	-	0.65	0.65	0.65	0.65	0.65	0.65	0.65
	Strength Reduction Factor - Submerged Concrete	$\lambda_{sub, ci}$	-	0.55	0.55	0.55	0.55	0.55	0.55	0.55
Periodic Inspection	Strength Reduction Factor - Dry Concrete	$\lambda_{dry, pi}$	-	0.55	0.55	0.55	0.55	0.55	0.55	0.55
	Strength Reduction Factor - Water-Saturated Concrete	$\lambda_{sat, pi}$	-	0.55	0.55	0.55	0.55	0.55	0.55	0.55
	Strength Reduction Factor - Water-Filled Holes	$\lambda_{wf, pi}$	-	0.55	0.55	0.55	0.55	0.55	0.55	0.55
	Strength Reduction Factor - Submerged Concrete	$\lambda_{sub, pi}$	-	0.45	0.45	0.45	0.45	0.45	0.45	0.45
Submerged Installation Reduction Factor	$\lambda_{N,sub}$	-	1.00	1.00	1.00	1.00	1.00	0.81	1.00	
Reduction factor for seismic tension	$\lambda_{N,seis}$	-	0.90	0.90	0.90	0.90	0.90	0.90	0.90	

For SI: 1 inch = 25.4mm, 1 lbf = 4.45N, 1ft-lbf = 1.356 N-M, 1 psi = 0.006895 MPa.

¹Bond strength values correspond to concrete compressive strengths ranging from 2,500 psi to 8,000.

²Temperature range A: Maximum short term temperature of 142°F and maximum long term temperature of 110°F.

³Temperature range B: Maximum short term temperature of 176°F and maximum long term temperature of 110°F.

⁴For load combinations consisting of only short-term loads, such as wind or seismic loads, bond strengths may be increased by 4 percent for Temperature Range B.

⁵For structures assigned to IBC or IRC Seismic Design Category C, D, E, or F, bond strength values must be multiplied by $\lambda_{N,seis}$.

⁶Characteristic bond strengths are for sustained loads, including dead and live loads.

TABLE 4—STEEL DESIGN INFORMATION FOR U.S. CUSTOMARY UNIT STEEL REINFORCING BARS ⁽¹⁾

CHARACTERISTIC	SYMBOL	UNITS	NOMINAL ROD DIAMETER (inch)								
			No. 3	No. 4	No. 5	No. 6	No. 7	No. 8	No. 9	No. 10	
Nominal bar diameter	d	in.	3/8	1/2	5/8	3/4	7/8	1	1 1/8	1 1/4	
Reinforcing bar effective cross-sectional area	A _{se}	inch ²	0.11	0.2	0.31	0.44	0.6	0.79	1.00	1.27	
ASTM 615 Grade 60	Nominal steel strength in tension	N _{sa}	lb	9,900	18,000	27,900	39,600	54,000	71,100	90,000	114,300
	Nominal steel strength in shear	V _{sa}	lb	5,940	10,800	16,740	23,760	32,400	42,660	54,000	68,580
	Strength reduction factor for tension, steel failure mode	ϕ	-	0.65	0.65	0.65	0.65	0.65	0.65	0.65	0.65
	Strength reduction factor for shear, steel failure mode ¹	ϕ	-	0.60	0.60	0.60	0.60	0.60	0.60	0.60	0.60
	Reduction factor for seismic shear	ϕ _{V,seis}	-	0.91	0.91	0.91	0.90	0.90	0.71	0.71	0.71

For SI: 1 inch = 25.4mm, 1 lbf = 4.45N, 1ft-lbf = 1.356 N-M, 1 psi = 0.006895 MPa.

¹The tabulated value of ϕ applies when the load combinations of Section 1605.2 of the IBC, ACI 318-14 5.3 or ACI 318-11 9.2 are used. If the load combinations of ACI 318-11 Appendix C are used, the appropriate value of ϕ must be determined in accordance with ACI 318-11 D.4.4.

TABLE 5—CONCRETE BREAKOUT DESIGN INFORMATION FOR U.S. CUSTOMARY UNIT STEEL REINFORCING BARS ^(1,2)

CHARACTERISTIC	SYMBOL	UNITS	NOMINAL ROD DIAMETER (inch)							
			No. 3	No. 4	No. 5	No. 6	No. 7	No. 8	No. 9	No. 10
Effectiveness factor for uncracked concrete	k _{uncr}	-	24	24	24	24	24	24	24	24
Effectiveness factor for cracked concrete	k _{cr}	-	17	17	17	17	17	17	17	17
Minimum concrete thickness	h _{min}	in.	h _{ef} + 1 1/4			h _{ef} + 2d _o				
Anchor embedment depth - minimum	h _{ef,min}	in.	1 1/2	2	2 1/2	3	3 1/2	4	4 1/2	5
Minimum spacing	s _{min}	in.	15/16	1 1/2	2 1/2	3	3 1/2	4	4 1/2	5
Minimum edge distance	c _{min}	in.	15/16	1 1/2	2 1/2	3	3 1/2	4	4 1/2	5
Critical edge distance	c _{ac}	in.	See Section 4.1.10 of this report							
Strength reduction factor for tension, concrete failure mode ¹	ϕ	Cond. B	0.65	0.65	0.65	0.65	0.65	0.65	0.65	0.65
Strength reduction factor for shear, concrete failure mode ¹	ϕ	Cond. B	0.70	0.70	0.70	0.70	0.70	0.70	0.70	0.70

For SI: 1 inch = 25.4mm, 1 lbf = 4.45N, 1ft-lbf = 1.356 N-M, 1 psi = 0.006895 MPa.

¹The tabulated value of ϕ applies when the load combinations of Section 1605.2 of the IBC, ACI 318-14 5.3 or ACI 318-11 9.2 are used and the requirements of ACI 318-14 17.3.3 or ACI 318-11 D.4.3, as applicable, for Condition B are met. If the load combinations of ACI 318-11 Appendix C are used, the appropriate value of ϕ must be determined in accordance with ACI 318-11 D.4.4 for Condition B.

²The value of f_c used for calculation must be limited to maximum 8,000 psi (55 MPa) in accordance with ACI 318-14 17.2.7 or ACI 318-11 D.3.7, as applicable.

TABLE 6—RED HEAD G5+ ADHESIVE ANCHOR BOND STRENGTH DESIGN INFORMATION FOR U.S. CUSTOMARY UNIT STEEL REINFORCING BARS INSTALLED IN HOLES PREPARED WITH A HAMMER DRILL AND CARBIDE BIT^(1,5,6)

CHARACTERISTIC	SYMBOL	UNITS	NOMINAL ROD DIAMETER (inch)								
			No. 3	No. 4	No. 5	No. 6	No. 7	No. 8	No. 9	No. 10	
Anchor embedment depth - minimum	h_{ef}	in.	1 ¹ / ₂	2	2 ¹ / ₂	3	3 ¹ / ₂	4	4 ¹ / ₂	5	
Anchor embedment depth - maximum	h_{ef}	in.	7 ¹ / ₂	10	12 ¹ / ₂	15	17 ¹ / ₂	20	22 ¹ / ₂	25	
Temperature Range A ²	Characteristic Bond Strength for Uncracked Concrete	$T_{k,uncr}$	psi	1,790	1,725	1,660	1,595	1,535	1,475	1,475	1,460
	Characteristic Bond Strength for Cracked Concrete	$T_{k,cr}$	psi	855	820	785	760	735	710	710	680
Temperature Range B ^{3,4}	Characteristic Bond Strength for Uncracked Concrete	$T_{k,uncr}$	psi	1,005	965	930	895	860	825	825	820
	Characteristic Bond Strength for Cracked Concrete	$T_{k,cr}$	psi	480	460	440	425	410	400	400	380
Continuous Inspection	Strength Reduction Factor - Dry Concrete	$\lambda_{dry, ci}$	-	0.65	0.65	0.65	0.65	0.65	0.65	0.65	0.65
	Strength Reduction Factor - Water-Saturated Concrete	$\lambda_{sat, ci}$	-	0.65	0.65	0.65	0.65	0.65	0.65	0.65	0.65
	Strength Reduction Factor - Water-Filled Holes	$\lambda_{wf, ci}$	-	0.65	0.65	0.65	0.65	0.65	0.65	0.65	0.65
	Strength Reduction Factor - Submerged Concrete	$\lambda_{sub, aci}$	-	0.55	0.55	0.55	0.55	0.55	0.55	0.55	0.55
Periodic Inspection	Strength Reduction Factor - Dry Concrete	$\lambda_{dry, pi}$	-	0.55	0.55	0.55	0.55	0.55	0.55	0.55	0.55
	Strength Reduction Factor - Water-Saturated Concrete	$\lambda_{sat, pi}$	-	0.55	0.55	0.55	0.55	0.55	0.55	0.55	0.55
	Strength Reduction Factor - Water-Filled Holes	$\lambda_{wf, pi}$	-	0.55	0.55	0.55	0.55	0.55	0.55	0.55	0.55
	Strength Reduction Factor - Submerged Concrete	$\lambda_{sub, pi}$	-	0.45	0.45	0.45	0.45	0.45	0.45	0.45	0.45
Submerged Installation Reduction Factor	$\lambda_{N,sub}$	-	1.00	1.00	1.00	1.00	1.00	0.81	0.81	1.00	
Reduction factor for seismic tension	$\lambda_{N,seis}$	-	0.84	0.84	0.84	0.84	0.84	0.84	0.84	0.84	

For SI: 1 inch = 25.4mm, 1 lbf = 4.45N, 1ft-lbf = 1.356 N-M, 1 psi = 0.006895 MPa.

¹Bond strength values correspond to concrete compressive strengths ranging from 2,500 psi to 8,000 psi.

²Temperature range A: Maximum short term temperature of 142°F and maximum long term temperature of 110°F.

³Temperature range B: Maximum short term temperature of 176°F and maximum long term temperature of 110°F.

⁴For load combinations consisting of only short-term loads, such as wind or seismic loads, bond strengths may be increased by 4 percent for Temperature Range B.

⁵For structures assigned to IBC or IRC Seismic Design Category C, D, E, or F, bond strength values must be multiplied by $\lambda_{N,seis}$.

⁶Characteristic bond strengths are for sustained loads, including dead and live loads

TABLE 7—EXAMPLE RED HEAD G5+ ADHESIVE ANCHOR ALLOWABLE STRESS DESIGN VALUES (ASD) FOR ILLUSTRATIVE PURPOSES

Anchor Diameter (d)	Min/Max Embedment Depth, h _{ef} (in)	Char. Bond Strength τ _{k,uncr} (psi)	Allowable Tension Load (lb) 2500psi- 8000psi	Controlling Failure Mode
3/8	2 3/8	1,790	1,930	Concrete
	7 1/2		2,280	Steel
1/2	2 3/4	1,725	2,405	Concrete
	10		4,170	Steel
5/8	3 1/8	1,660	2,910	Concrete
	12 1/2		6,645	Steel
3/4	3 1/2	1,595	3,450	Concrete
	15		9,830	Steel
7/8	3 1/2	1,535	3,450	Concrete
	17 1/2		13,570	Steel
1	4	1,475	4,215	Concrete
	20		17,800	Steel
1 1/4	5	1,460	5,890	Concrete
	25		28,485	Steel

For SI: 1 inch = 25.4mm, 1 lbf = 4.45N, 1ft-lbf = 1.356 N-M, 1 psi = 0.006895 MPa.

This table was developed based on the following conditions:

- ¹Single anchor with static tension only, A36 threaded rod
- ²Vertical downward installation direction
- ³Inspection regimen = Periodic
- ⁴Installation temperature = 50°F to 110°F
- ⁵Long term temperature = 110°F
- ⁶Short term temperature = 142°F
- ⁷Dry hole condition (carbide drilled hole)
- ⁸Embedment = h_{ef} (min/max for each diameter)
- ⁹Concrete determined to remain uncracked for the life of the anchorage
- ¹⁰Load combinations from ACI 318-11 Section 9.2 (no seismic loading)
- ¹¹30% dead load and 70% live load, controlling load combination 1.2D + 1.6L
- ¹²Calculation of weighted average for α = 0.3*1.2 + 0.7*1.6 = 1.48
- ¹³f_c = 2,500 psi (normal-weight concrete)
- ¹⁴C_{a1} = C_{a2} ≥ C_{ac}
- ¹⁵h ≥ h_{min}

Illustrative Procedure to Calculate Allowable Stress Design Tension Value:

Red Head G5+ Adhesive Anchor 1/2-inch diameter, using an embedment of 4 1/2 inches, assuming the conditions given in Table 7 (for use with the 2012 IBC, based on ACI 318-11 Appendix D). Applied tension load, N_{ua} = 4,000 lbs.

	PROCEDURE	CALCULATION
Step 1	Calculate steel strength of a single anchor in tension per ACI 318-11 D.5.1.2 and Table 1 of this report.	$N_{sa} = 0.75 * 8,230 = 6,173$ lbs steel strength
Step 2	Calculate concrete breakout strength of a single anchor in tension per ACI 318-11 D.5.2 and Table 2 of this report.	$N_b = k_{c,uncr} * \sqrt{f_c} * h_{ef}^{1.5} = 24 * \sqrt{2,500} * 4.5^{1.5}$ $N_b = 11,455$ lbs $N_{cb} = A_{NC} / A_{NC0} * \psi_{ed,N} * \psi_{c,N} * \psi_{cp,N} * N_b$ $N_{cb} = 0.65 * 1.0 * 1.0 * 1.0 * 11,455$ $N_{cb} = 7,446$ lbs concrete breakout strength
Step 3	Calculate bond strength of a single anchor in tension per ACI 318-11 D.5.5 and Table 3 of this report.	$N_{ba} = * \sqrt{f_c} * h_{ef} * \psi_{ed,N} * \psi_{c,N} * \psi_{cp,N} * N_{ao}$ $N_{ba} = 1.0 * 1,725 * 3.14 * 0.5 * 4.5$ $N_{ba} = 8,512$ lbs $N_a = A_{Na} / A_{Na0} * \psi_{ed,N} * \psi_{c,N} * \psi_{cp,N} * N_{ao}$ $N_a = 0.65 * 1.0 * 1.0 * 1.0 * 8,512$ $N_a = 5,533$ lbs bond strength
Step 4	Determine compliance with required anchor strength per ACI 318-11 D.4.1.	$N_{sa} = 6,173$ lbs > N _{ua} = 4,000 lbs $N_{cb} = 7,446$ lbs > N _{ua} = 4,000 lbs $N_a = 5,533$ lbs > N _{ua} = 4,000 lbs
Step 5	Calculate allowable stress design conversion factor for loading condition per ACI 318-11 Section 9.2.	$\alpha = 1.2D + 1.6L = 1.2(0.3) + 1.6(0.7) = 1.48$
Step 6	Calculate allowable stress design value per Section 4.2 of this report.	$T_{allowable,ASD} = N_a / \alpha = 5,533$ lbs / 1.48 $T_{allowable,ASD} = 3,738$ lbs allowable stress design

FIGURE 2—EXAMPLE DESIGN CALCULATION

RED HEAD G5+ ADHESIVE ANCHOR INSTALLATION INSTRUCTION

Hammer Drilling Installation

* Water-saturated concrete, water-filled holes and submerged concrete applications require 4x's air, 4x's brushing and 4x's air

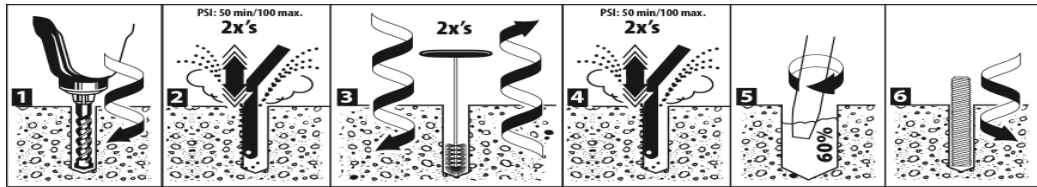

- 1)
 - Use a rotary hammer drill with a carbide drill bit complying to ANSI B212.15-1994 tolerance requirements. Drill hole to the required embedment depth. See attached table for drill bit specifications and min/maximum embedment depths.
 - Installations may be used with maximum 1-1/4" diameter rods/rebar for floor, wall and overhead applications.
 - Per construction specification, adhere to minimum spacing, minimum edge distance, and minimum member thickness.
 - 2)
 - For dry holes, oscillate a clean air nozzle in and out of the dry hole two times, for a total of two seconds, starting at the bottom of the hole with contaminant-free compressed air, exhausting hole until visually clean (i.e., no dust, debris, etc.)
 - For water-saturated concrete and water-filled hole applications, oscillate a clean air nozzle in and out of the damp, water-filled or submerged hole four times, for a total of four seconds, starting at the bottom of the hole with contaminant-free compressed air, exhausting hole until visually clean (i.e., no dust, debris, etc.)
 - If required, use an extension on the end of the air nozzle to reach the bottom of the hole.
 - 3)
 - Select an appropriately sized Red Head brush for the anchor diameter. Brush must be checked for wear before use. See attached table for brush specifications, including minimum diameter.
 - Insert the brush into the hole with a clockwise motion. For every 1/2" forward advancement, complete one full turn until bottom of hole is reached. For faster and more suitable cleaning, attach the brush to a drill.
 - Using a clockwise motion, for every full turn of the brush, pull the brush 1/2" out of the hole.
 - For dry holes, twist/spin the brush two times in/out of the hole.
 - For water-saturated concrete and water-filled hole applications, twist/spin the brush four times in/out of the hole.
 - If required, use a wire brush extension (part nos. ESDS-38 or EHAN-38) to reach the bottom of the hole.
 - Air clean the dust off the brush to prevent clogging of the brush.
 - 4)
 - For dry holes, oscillate a clean air nozzle in and out of the dry hole two times, for a total of two seconds, starting at the bottom of the hole with contaminant-free compressed air, exhausting hole until visually clean (i.e., no dust, debris, etc.)
 - For water-saturated concrete and water-filled hole applications, oscillate a clean air nozzle in and out of the damp, water-filled or submerged hole four times, for a total of four seconds, starting at the bottom of the hole with contaminant-free compressed air, exhausting hole until visually clean (i.e., no dust, debris, etc.)
 - 5)
 - Review the Safety Data Sheet (SDS) before use.
 - Check the "Use By" date on the cartridge and that the cartridge has been stored out of direct sunlight.
 - Review the gel time/cure time chart, based on the temperature at time of installation, to determine tool, cartridge and nozzle requirements.
 - Assemble the Red Head supplied cartridge and nozzle. Do not modify or remove mixing elements in nozzle.
- If nozzle does not reach the bottom of the hole, use Red Head E25-6 extension tubing (0.44" O.D.) positioned on the end of nozzle or use the S75EXT (nozzle extension) on the end of the S75 nozzle.
 - Place the assembly into a hand injection tool or a pneumatic injection tool.
 - Dispense mixed adhesive outside of hole until uniform color is achieved.
 - During installations, concrete must be between 50 and 110 degrees F, or artificially maintained.
 - Insert the nozzle to the bottom of the hole and inject the adhesive at an angle, leaving the nozzle tip always slightly below the fill level.
 - In a slow circular direction, work the adhesive into the sides of the hole, filling slowly to ensure proper adhesive distribution, until the hole is approximately 60% filled.
 - For holes that contain water, keep injecting the adhesive below the water to displace the water upward.
- HORIZONTAL AND OVERHEAD INJECTION OF ADHESIVE:**
- For 3/8" and 1/2" diameter anchors installed horizontal and overhead, the adhesive may be injected directly to the back end of the hole using required Red Head E916-6 extension tubing (0.56" O.D.) for the 1/2" diameter anchors and Red Head E25-6 extension tubing (0.44" O.D.) for the 3/8" diameter anchors.
 - For 5/8" diameter rod (#5 rebar) and larger anchors installed horizontal and overhead, assemble Red Head E916-6 extension tubing (0.56" O.D.) and appropriate sized piston plug on end of tubing:
 - PL-5834 for 5/8" & 3/4" diameter rod (No. 5 and No. 6 rebar)
 - PL-7810 for 7/8" & 1" diameter rod (No. 7 and No. 8 rebar)
 - PL-1250 for 1-1/4" diameter rod (No. 9 and No. 10 rebar)
 - The use of the Red Head pneumatic tool may be required for larger diameter anchor and/or deeper embedment installations at temperatures up to 110 degrees F.
- 6)
 - Immediately insert the oil, rust and scale free rod/rebar assembly to the required embedment depth, using a counterclockwise motion to ensure proper adhesive distribution.
 - The anchor rod/rebar must be marked with the required embedment depth.
 - For wall (horizontal) and overhead installations with concrete or adhesive over 70 degrees F, the anchor rod/rebar must be marked with the required embedment depth and assembled with a Red Head hole plug positioned on the rod/rebar at the required embedment depth.
 - After installing the anchor, the gap between the rod and the concrete must be completely filled with adhesive. The adhesive must fill voids, crevices and uniformly coat the rod and concrete.
 - After installation, do not disturb the anchor until the full cure time has elapsed. Overhead installations must be supported until full cure time has elapsed.
 - Adhesive must be fully cured before applying any load or torque. Do not over torque the anchor as this could adversely affect its performance.

FIGURE 3—RED HEAD G5+ ADHESIVE INSTALLATION INSTRUCTIONS

SPECIFICATIONS FOR INSTALLATION OF RED HEAD G5+ ADHESIVE ANCHORS IN CONCRETE

FOR INSTALLATION USING U.S. CUSTOMARY UNIT STEEL THREADED ROD

CHARACTERISTIC	SYMBOL	UNITS	NOMINAL ROD DIAMETER (inch)						
			3/8	1/2	5/8	3/4	7/8	1	1 1/4
Nominal carbide bit diameter	-	in.	7/16	9/16	3/4	7/8	1	1 1/8	1 3/8
Anchor embedment depth - minimum	$h_{ef, min}$	in.	1 1/2	2	2 1/2	3	3 1/2	4	5
Anchor embedment depth - maximum	$h_{ef, max}$	in.	7 1/2	10	12 1/2	15	17 1/2	20	25
Minimum spacing	s_{min}	in.	15/16	1 1/2	2 1/2	3	3 1/2	4	5
Minimum edge distance	c_{min}	in.	15/16	1 1/2	2 1/2	3	3 1/2	4	5
Minimum concrete thickness	h_{min}	in.	$h_{ef} + 1 1/4$			$h_{ef} + 2d_o$			
Maximum tightening torque for pretension clamping	T_{inst}	ft lb	9	16	47	70	90	110	370

FOR INSTALLATION USING U.S. CUSTOMARY UNIT STEEL REINFORCING BARS

CHARACTERISTIC	SYMBOL	UNITS	NOMINAL REBAR DIAMETER (inch)							
			No. 3	No. 4	No. 5	No. 6	No. 7	No. 8	No. 9	No. 10
Nominal carbide bit diameter	-	in.	7/16	5/8	3/4	7/8	1	1 1/8	1 1/4	1 3/8
Anchor embedment depth - minimum	$h_{ef, min}$	in.	1 1/2	2	2 1/2	3	3 1/2	4	4 1/2	5
Anchor embedment depth - maximum	$h_{ef, max}$	in.	7 1/2	10	12 1/2	15	17 1/2	20	22 1/2	25
Minimum spacing	s_{min}	in.	15/16	1 1/2	2 1/2	3	3 1/2	4	4 1/2	5
Minimum edge distance	c_{min}	in.	15/16	1 1/2	2 1/2	3	3 1/2	4	4 1/2	5
Minimum concrete thickness	h_{min}	in.	$h_{ef} + 1 1/4$			$h_{ef} + 2d_o$				

For SI: 1 inch = 25.4mm, 1 lbf = 4.45N, 1ft-lbf = 1.356N-m, 1psi = 0.006895MPa.

ANCHOR INSTALLATION

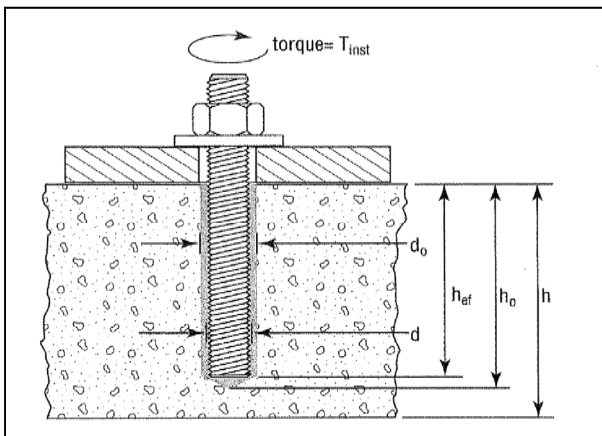

BRUSH, NOZZLE, EXTENSION TUBING AND PISTON PLUG SPECIFICATIONS

Anchor diameter (in) (d)	Brush Part No.	Minimum brush diameter (in)	Mixing nozzle	USE of extension tubing ONLY Part No	USE of Piston Plug with extension tubing Part Nos.
3/8	WB038	0.563	A24S or S55	E25-6	-
1/2	WB012	0.675	A24S or S55	E25-6	-
5/8	WB058	0.900	A24S or S55	-	PL-5834 E916-6
3/4	WB034	1.125	S55 or S75/S75EXT	-	PL-5834 E916-6
7/8	WB078	1.350	S55 or S75/S75EXT	-	PL-7810 E916-6
1 & 1/8	WB100	1.463	S55 or S75/S75EXT	-	PL-7810 E916-6
1 1/4	WB125	1.575	S55 or S75/S75EXT	-	PL-1250 E916-6

FIGURE 3—RED HEAD G5+ ADHESIVE INSTALLATION INSTRUCTIONS (Continued)

CURE TIMES AND GEL TIMES FOR RED HEAD G5+ ADHESIVE

Concrete Temperature (°F) ¹	Gel Time ²	Cure Time ³
110	10 minutes	4 hours
90	14 minutes	6 hours
70	16 minutes	8 hours
50	30 minutes	30 hours

For **SI**: $t^{\circ} (\text{°F}-32) \times .555 = \text{°C}$.

¹Adhesive must be installed in concrete temperatures within the noted range or artificially maintained at the noted temperature.

²Gel time is the maximum time from the end of mixing to when the insertion of the anchor into the adhesive must be completed and is based upon the adhesive and concrete temperatures noted.

³Cure time is the minimum time from the end of gel time to when the anchor maybe torque or loaded. Anchors are to be undisturbed during the cure time.

FIGURE 3—RED HEAD G5+ ADHESIVE INSTALLATION INSTRUCTIONS (Continued)

ICC-ES Evaluation Report

ESR-4138 LABC and LARC Supplement

Issued September 2017

This report is subject to renewal September 2018.

www.icc-es.org | (800) 423-6587 | (562) 699-0543

A Subsidiary of the International Code Council®

DIVISION: 03 00 00—CONCRETE
Section: 03 16 00—Concrete Anchors

DIVISION: 05 00 00—METALS
Section: 05 05 19—Post-Installed Concrete Anchors

REPORT HOLDER:

ITW RED HEAD
700 HIGH GROVE BOULEVARD
GLENDALE HEIGHTS, ILLINOIS 60139
(800) 848-5611
www.itw-redhead.com
techsupport@itwccna.com

EVALUATION SUBJECT:

ITW RED HEAD G5+ ADHESIVE ANCHORING SYSTEM FOR CRACKED AND UNCRACKED CONCRETE

1.0 REPORT PURPOSE AND SCOPE

Purpose:

The purpose of this evaluation report supplement is to indicate that the ITW Red Head G5+ Adhesive Anchoring System for cracked and uncracked concrete, described in ICC-ES master evaluation report [ESR-4138](#), has also been evaluated for compliance with the codes noted below as adopted by the Los Angeles Department of Building and Safety (LADBS).

Applicable code editions:

- ☐ 2017 City of Los Angeles Building Code (LABC)
- ☐ 2017 City of Los Angeles Residential Code (LARC)

2.0 CONCLUSIONS

The ITW Red Head G5+ Adhesive Anchoring System for cracked and uncracked concrete, described in Sections 2.0 through 7.0 of the master evaluation report [ESR-4138](#), complies with LABC Chapter 19, and LARC, and is subjected to the conditions of use described in this supplement.

3.0 CONDITIONS OF USE

The ITW Red Head G5+ Adhesive Anchoring System described in this evaluation report must comply with all of the following conditions:

- ☐ All applicable sections in the master evaluation report [ESR-4138](#).
- ☐ The design, installation, conditions of use and identification of the anchoring system are in accordance with the 2015 International Building Code® (2015 IBC) provisions noted in the master evaluation report [ESR-4138](#).
- ☐ The design, installation and inspection are in accordance with additional requirements of LABC Chapters 16 and 17, as applicable.
- ☐ Under the LARC, an engineered design in accordance with LARC Section R301.1.3 must be submitted.
- ☐ The allowable and strength design values listed in the master evaluation report and tables are for the connection of the adhesive anchors to the concrete. The connection between the adhesive anchors and the connected members shall be checked for capacity (which may govern).

This supplement expires concurrently with the master report, issued September 2017.

ICC-ES Evaluation Report

ESR-4138 FBC Supplement

Issued September 2017

This report is subject to renewal September 2018.

www.icc-es.org | (800) 423-6587 | (562) 699-0543

A Subsidiary of the International Code Council®

DIVISION: 03 00 00—CONCRETE
Section: 03 16 00—Concrete Anchors

DIVISION: 05 00 00—METALS
Section: 05 05 19—Post-Installed Concrete Anchors

ITW RED HEAD
700 HIGH GROVE BOULEVARD
GLENDALE HEIGHTS, ILLINOIS 60139
(800) 848-5611

www.itw-redhead.com
techsupport@itwccna.com

EVALUATION SUBJECT:

ITW RED HEAD G5+ ADHESIVE ANCHORING SYSTEM FOR CRACKED AND UNCRACKED CONCRETE

1.0 REPORT PURPOSE AND SCOPE

Purpose:

The purpose of this evaluation report supplement is to indicate that the Red Head G5+ Adhesive Anchoring System for Cracked and Uncracked Concrete, recognized in ICC-ES master evaluation report ESR-4138, has also been evaluated for compliance with the codes noted below.

Compliance with the following codes:

- ☐ 2014 Florida Building Code—Building
- ☐ 2014 Florida Building Code—Residential

2.0 PURPOSE OF THIS SUPPLEMENT

This supplement is issued to indicate that the Red Head G5+ Adhesive Anchoring System for Cracked and Uncracked Concrete described in Sections 2.0 through 7.0 of the master report, ESR-4138, complies with the Florida Building Code—Building and the Florida Building Code—Residential, when designed and installed in accordance with the 2012 International Building Code® (IBC) provisions noted in the master evaluation report under the following conditions:

- ☐ Design wind loads must be based on Section 1609 of the Florida Building Code—Building or Section 301.2.1.1 of the Florida Building Code—Residential, as applicable.
- ☐ Load combinations must be in accordance with Section 1605.2 or Section 1605.3 of the Florida Building Code—Building, as applicable.

Use of the Red Head G5+ Adhesive Anchoring System with stainless steel threaded rod materials has also been found to be in compliance with the High-Velocity Hurricane Zone provisions of the Florida Building Code—Building and the Florida Building Code—Residential when the following condition is met:

The design wind loads for use of the anchors in a High-Velocity Hurricane Zone are based on Section 1620 of the Florida Building Code—Building.

Use of the the Red Head G5+ Adhesive Anchoring System with carbon steel threaded rod materials and reinforcing bars for compliance with the High-velocity Hurricane Zone provisions of the Florida Building Code—Building and the Florida Building Code—Residential has not been evaluated, and is outside the scope of this supplemental report.

For products falling under Florida Rule 9N-3, verification that the report holder's quality-assurance program is audited by a quality-assurance entity approved by the Florida Building Commission for the type of inspections being conducted is the responsibility of an approved validation entity (or the code official, when the report holder does not possess an approval by the Commission).

This supplement expires concurrently with the master report issued, September 2017.