

CCMC 12678-R

CCMC Canadian code compliance evaluation

CCMC number:	12678-R
Status:	Active
Issue date:	1995-04-28
Modified date:	2022-11-22
Evaluation holder:	<p>James Hardie Building Products, Inc. 26300 La Alameda, Suite 400 Mission Viejo CA 92691 United States Website: www.jameshardie.com Telephone: 909-356-6366 Email: info@jameshardie.com</p>
Product names:	<ul style="list-style-type: none"> • Artisan[®] Lap Siding • Artisan[®] Siding with Lock Joint System • HardiePanel[®] HZ5[™] Vertical Siding • HardiePlank[®] HZ5[™] Lap Siding • HardieShingle[®] HZ5[™] Individual Shingle • HardieShingle[®] HZ5[™] Notched Panels
Code compliance:	NBC 2015, OBC
Evaluation requirements:	CCMC-TG-074645.01-15 "CCMC Technical Guide for Cellulose Reinforced Fibre Cement Cladding"

In most jurisdictions this document is sufficient evidence for approval by Canadian authorities.

[Learn more about CCMC recognition](#) [Look for the trusted CCMC mark on products to verify compliance.](#)

Code compliance opinion

It is the opinion of the Canadian Construction Materials Centre that the [evaluated products](#), when used as exterior cladding in accordance with the [conditions and limitations](#) stated in this evaluation, comply with the following code:

National Building Code of Canada 2015

Code provision	Solution type
9.27.2. Required Protection from Precipitation	<u>Acceptable</u>
9.27.5. Attachment of Cladding	<u>Alternative</u>
9.27.9. Hardboard	<u>Alternative</u>

Ontario Building Code

Ruling No. 95-17-36 (12678-R) authorizing the use of this product in Ontario, subject to the terms and conditions contained in the Ruling, was made by the Minister of Municipal Affairs and Housing on 1995-11-29 (revised 2012-06-13) pursuant to s.29 of the Building Code Act, 1992 (see Ruling for terms and conditions). This Ruling is subject to periodic revisions and updates.

The above opinion is based on the evaluation by the CCMC of technical evidence provided by the evaluation holder, and is bound by the stated [conditions and limitations](#). For the benefit of the user, a summary of the [technical information](#) that forms the basis of this evaluation has been included.

Product information

Product names

- Artisan[®] Lap Siding
- Artisan[®] Siding with Lock Joint System
- HardiePanel[®] HZ5[™] Vertical Siding
- HardiePlank[®] HZ5[™] Lap Siding
- HardieShingle[®] HZ5[™] Individual Shingle
- HardieShingle[®] HZ5[™] Notched Panels

Product description

The products are fibre cement boards made primarily of hydraulic cement, silica, and other additives and reinforced integrally with cellulose fibres. The products are manufactured using the Hatschek process and steam autoclaved. They are intended for use as an exterior cladding applied to vertical masonry or concrete walls, as well as cementitious and wood sheathing that are attached to wood or steel framing, subject to the conditions and limitations stated in the [conditions and limitations](#) section of this Report. See also the manufacturer's installation instructions, dated March 2020, for details and restrictions.

In addition to the sizes for each of the products listed below, additional lengths and widths may be available from the manufacturer by special order.

HardiePanel[®] HZ5[™] Vertical Siding

HardiePanel[®] HZ5[™] Vertical Siding is available in panels that are 2 440 mm to 3 050 mm long, 1 220 mm wide and 7.5 mm thick. The panels are available in a smooth, stucco pattern or a wood grain face texture.

The panels are installed with a drained and vented air space not less than 10 mm deep behind the cladding. The vertical joints of the panels must butt over the framing members (studs).



Figure 1. HardiePanel® HZ5™ Vertical Siding

HardiePlank® HZ5™ Lap Siding

HardiePlank® HZ5™ Lap Siding is available in planks that are 3 660 mm long, 133 mm to 305 mm high and 7.5 mm thick. The planks are available in a smooth or wood grain face texture.

The planks are installed starting at the bottom of the wall with a minimum overlap of 32 mm. The vertical joints of the planks must butt over the framing members (studs). The lap siding is fastened either through the overlapping planks (face nailed) with corrosion-resistant nails or screws, or through the top edge of the planks (blind nailed).

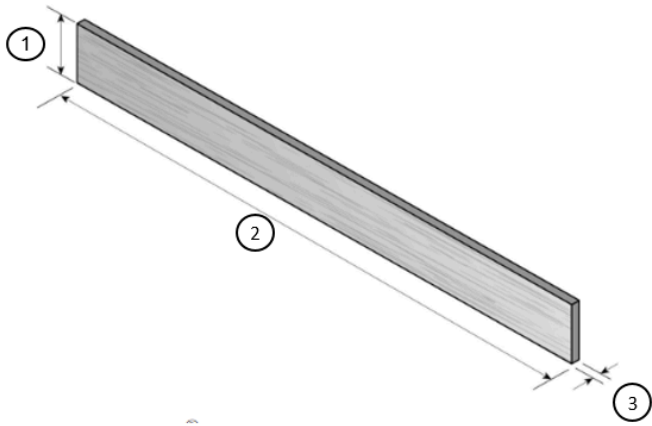

Figure 2. HardiePlank® HZ5™ Lap Siding

1. 133 to 305 mm
2. 3660 mm
3. 7.5 mm

HardieShingle® HZ5™ Notched Panels

HardieShingle® HZ5™ Notched Panels are available in three variations: a straight edge panel, a staggered edge panel and a half round panel. The panels are 404 mm high, 1 220 mm long and 6 mm thick. The panels are available in a wood grain texture.



Figure 3. HardieShingle® HZ5™ Notched Panels - straight edge



Figure 4. HardieShingle® HZ5™ Notched Panels – staggered edge

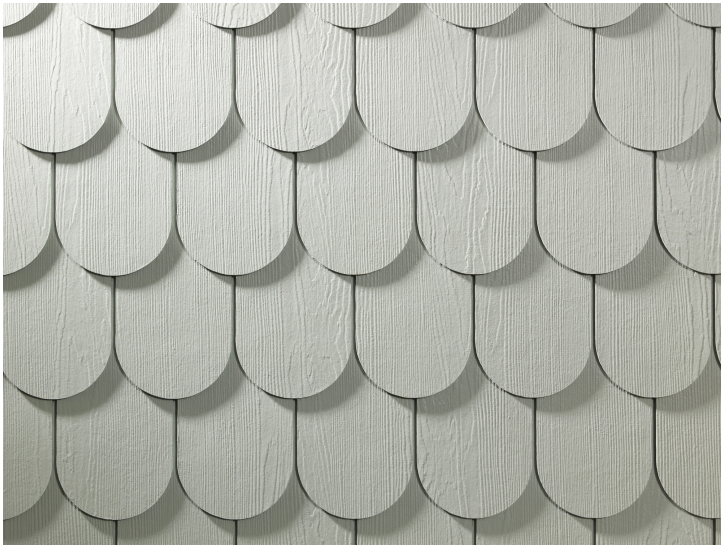

Figure 5. HardieShingle® HZ5 Notched Panels – half round

HardieShingle® HZ5™ Individual Shingle

HardieShingle® HZ5™ Individual Shingle is available in cladding shingles that are 381 mm high, 105 mm to 250 mm wide and 6 mm thick. The shingles are available in a wood grain texture.

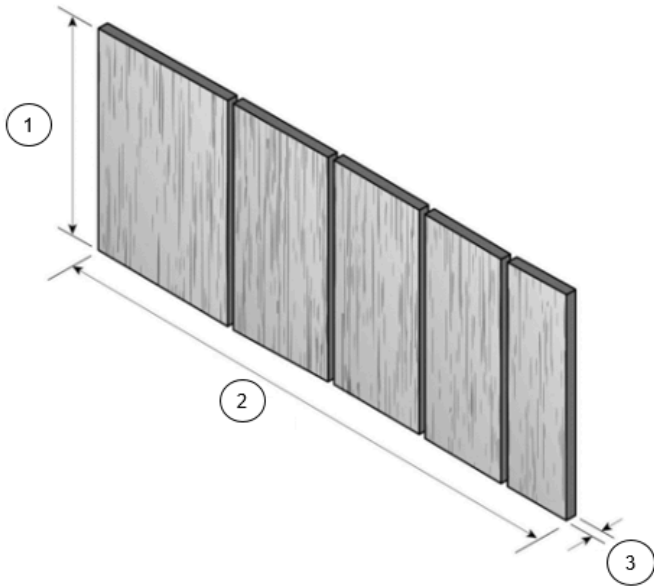

Figure 6. HardieShingle® HZ5™ Individual Shingle

1. 381 mm
2. 105 to 250 mm
3. 6 mm

Artisan® Lap Siding

Artisan® Lap Siding is available in planks that are 3 660 mm long, 133 mm to 209 mm high and 16 mm thick. The planks are available in a smooth and wood grain face texture and have tongue-and-groove vertical joints.

The planks are installed starting at the bottom of the wall with a minimum overlap of 32 mm. The lap siding is fastened either through the overlapping planks (face nailed) with corrosion-resistant nails or screws, or through the top edge of the planks (blind nailed).

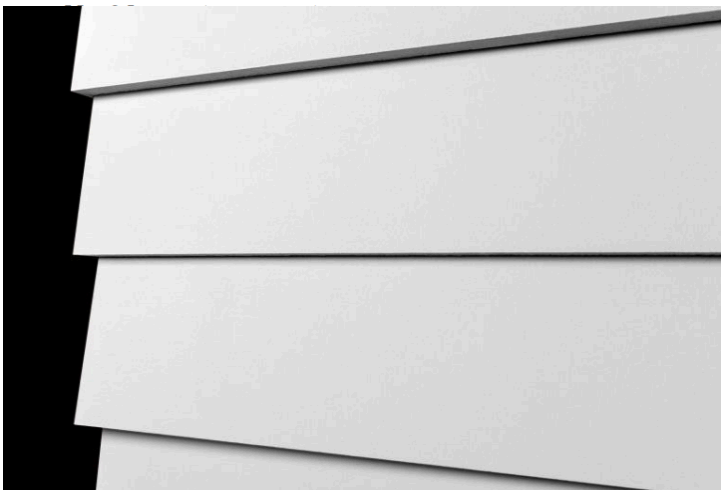

Figure 7. Artisan® Lap Siding

Artisan® Siding with Lock Joint System

Artisan® Siding with Lock Joint System is available in planks that are 3 660 mm long, 209 mm and 260 mm high and 16 mm thick. The planks are available in a smooth and wood grain face texture and have tongue-and-groove longitudinal joints. Artisan® Siding with Lock Joint System is installed both horizontally and vertically. The product has four joint profiles: V Groove, Square Channel, Bevel Channel and Shiplap.

The panels are installed with a drained and vented air space not less than 10 mm deep behind the cladding. The vertical joints of the panels must butt over the framing members (studs).



Figure 8. Artisan® Siding with Lock Joint System

Manufacturing plants

This evaluation is limited to products produced at the following plants:

Product names	Manufacturing plants							
	Cleburne, TX, US	Fontana, CA, US	McCarran, NV, US	Peru, IL, US	Plant City, FL, US	Pulaski, VA, US	Tacoma, WA, US	Waxahachie, TX, US
Artisan® Lap Siding	☑	☑	☑	☑	☑	☑	☑	☑
Artisan® Siding with Lock Joint System	☑	☑	☑	☑	☑	☑	☑	☑
HardiePanel® HZ5™ Vertical Siding	☑	☑	☑	☑	☑	☑	☑	☑
HardiePlank® HZ5™ Lap Siding	☑	☑	☑	☑	☑	☑	☑	☑
HardieShingle® HZ5™ Individual Shingle	☑	☑	☑	☑	☑	☑	☑	☑
HardieShingle® HZ5™ Notched Panels	☑	☑	☑	☑	☑	☑	☑	☑

☑ Indicates that the product from this manufacturing facility has been evaluated by the CCMC

Conditions and limitations

The CCMC's compliance opinion is bound by this product being used in accordance with the conditions and limitations set out below.

HardiePlank® HZ5™ Lap Siding, HardieShingle® HZ5™ Notched Panels, HardieShingle® HZ5™ Individual Shingle and Artisan® Lap Siding

All areas:

- The products are intended for use as an exterior cladding applied over exterior walls of buildings falling within the scope of Part 9, Housing and Small Buildings, of Division B of the National Building Code (NBC) of Canada 2015.
- The products are applied to vertical walls of masonry or concrete, as well as cementitious and wood sheathing that are attached to wood or steel framing.
- When used in existing buildings, the applicable elements of the existing buildings must comply with the requirements of the NBC 2015.
- This Report covers the installation of the products limited to the geographical areas with the hourly wind pressures (HWP) shown in the Results of testing the wind load resistance of the products for non-post-disaster buildings table and the respective fastening schedule to a wood or steel frame.
- The performance level shown in the Results of testing the wind load resistance of the products for non-post-disaster buildings table is for installations limited to non-post-disaster buildings with the maximum building height of 12 m or 20 m, depending on the geographical areas with HWP. The performance level in the Results of testing the wind load resistance of the products for non-post-disaster buildings table for the building height of 20 m is shown for information purposes only for use in the engineering design by a professional engineer.
- Buildings up to three storeys high (12 m) fall under the scope of Part 9 of Division B of the NBC 2015.
- Buildings higher than 12 m fall under the scope of Part 4 of Division B of the NBC 2015. In accordance with the NBC 2015, the engineering design must be prepared by a professional engineer licensed to practise in Canada who has expertise in a relevant area.
- A clearance of not less than 200 mm shall be provided between finished ground and the product.
- At least one layer of wall sheathing membrane conforming to Article 9.27.3.2., Sheathing Membrane Material Standard, of Division B of the NBC 2015, must be applied beneath the cladding products.
- Where no sheathing is used, at least two layers of sheathing membrane must be applied beneath the cladding products in accordance with Article 9.27.3.5., Sheathing Membrane in lieu of Sheathing, of Division B of the NBC 2015.
- If sheathing is required as part of the structure of the wood-frame construction (e.g., braced walls), a proper second plane of protection shall be provided in accordance with Subsection 9.27.3., Second Plane of Protection, of Division B of the NBC 2015.

Areas defined in Sentence 9.27.2.2.(5) of Division B of the NBC 2015:

- Sentence 9.27.2.2.(5) of Division B of the NBC 2015 defines the area where the number of degree-days is less than 3 400 and the moisture index is greater than 0.90, or the number of degree-days is 3 400 or more, and the moisture index is greater than 1.00.
- For applications in the areas as defined by Sentence 9.27.2.2.(5) of Division B of the NBC 2015, all listed products must be installed over wood strapping creating a drained and vented air space not less than 10 mm deep behind the cladding in conformance with Clause 9.27.2.2.(1)(a), Sentences 9.27.2.2.(2), and 9.27.5.7.(2),

Penetration of Fasteners, and Articles 9.27.5.3., Furring, and 9.27.5.4., Size and Spacing of Fasteners, of Division B of the NBC 2015.

- The drained and vented air space described in Clause 9.27.2.2.(1)(a) of Division B of the NBC 2015 must remain unobstructed.

Areas not defined in Sentence 9.27.2.2.(5) of Division B of the NBC 2015:

- For direct application in these areas, ⁽¹⁾ ⁽²⁾ the air space between the substrate and the products that is created as a result of the overlap of the cladding boards must remain unobstructed.

HardiePlank® HZ5™ Lap Siding

- For direct application of HardiePlank® HZ5™ Lap Siding in these areas, the butt joint must consist of factory-finished ends in conjunction with a joint flashing behind the joint, which consists of a 150-mm-wide Code-prescribed sheathing membrane ⁽²⁾ that overlaps the course below by 25 mm. The butt joint must be lined up and be supported by a stud.

HardiePanel® HZ5™ Vertical Siding and Artisan® Siding with Lock Joint System

- In all areas, HardiePanel® HZ5™ Vertical Siding must be installed over wood strapping, creating a drained and vented air space not less than 10 mm deep behind the cladding in conformance with Clause 9.27.2.2.(1)(a), Sentences 9.27.2.2.(2) and 9.27.5.7.(2), and Articles 9.27.5.3. and 9.27.5.4., of Division B of the NBC 2015.

Cladding system installation details

- Installation of the products must meet the requirements of Article 9.27.3.8., Flashing Installation, and Subsections 9.27.4., Sealants, and 9.27.5., Attachment of Cladding, of Division B of the NBC 2015.
- Fasteners for the attachment of products shall be corrosion-resistant and shall be compatible with the products in compliance with the requirements of Article 9.27.5.5., Fastener Materials, of Division B of the NBC 2015.
- The attachment of the cladding conforms to the Results of testing the wind load resistance of the products for non-post-disaster buildings table of this Report.
- The products must be installed in conjunction with materials conforming to Articles 9.27.3.2., Sheathing Membrane Material Standard, and 9.27.3.7., Flashing Materials, and Subsections 9.27.4. and 9.27.5. of Division B of the NBC 2015.
- The requirements of Article 9.10.16.1., Required Fire Blocks in Concealed Spaces, of Division B of the NBC 2015 must be met.
- The product must be installed in accordance with the manufacturer's current installation instructions:
 - HS1235 2/14 for HardiePanel® HZ5™ Vertical Siding,
 - HS11118 2/14 for HardiePlank® HZ5™ Lap Siding,
 - HS11120 2/14 for HardieShingle® HZ5™ Notched Panels” and HardieShingle® HZ5™ Individual Shingle,
 - ASP1841 P1/8 03/20 for Artisan® Lap Siding and
 - ASP1836 P1/9 04/19 for Artisan® Siding with Lock Joint System.
- In case of any discrepancies between the installation instructions and the conditions and limitations of this evaluation report, conditions and limitations of this evaluation report shall govern.
- If the fastening schedules in the manufacturer's installation instructions differ from those tested and reported in the Results of testing the wind load resistance of the products for non-post-disaster buildings table of this Report,

the ones in the [Results of testing the wind load resistance of the products for non-post-disaster buildings](#) table supersede.

- The technical opinion in this Report is limited to uncoated products. The manufacturer may provide primed or prepainted products. Low water vapour permeance coatings may affect the drying potential of the product as well as the substrate on which it is installed. Such a situation could lead to premature deterioration of the substrate and other elements in the wall assembly. The manufacturer's recommendations for type and characteristics of coatings to be used in conjunction with the cladding must be followed.
- The possibility of moisture accumulation within the wall construction is mainly a function of the level of workmanship related to the elements constituting the second plane of protection as defined in Article 9.27.2.3. of Division B of the NBC 2015, such as wall sheathing membrane, flashing, caulking and attachment of siding. A high level of quality control at all stages of the exterior wall construction is imperative for obtaining an acceptable performance.
- The products shall be applied in geographical areas where the spectral response acceleration $S_a(0.2)$ is 1.2 or less and the building is on a Class C site or better, as defined in Article 4.1.8.4., Site Properties, of Division B of the NBC 2015.
- This Evaluation Report is applicable only to products identified with "CCMC 12678-R."

Notes:

- 1 A moisture management study performed on HardiePlank® HZ5™ Lap Siding, HardieShingle® HZ5™ Notched Panels and HardieShingle® HZ5™ Individual Shingle indicated that these products can be installed with direct application in areas other than those defined in Sentence 9.27.2.2.(5) of Division B of the NBC 2015.
- 2 These direct-applied cementitious claddings were not evaluated when in contact with polymer-based sheathing membranes (see limitations in CCMC Reports of polymer-based sheathing membranes). The NBC-prescribed, asphalt-impregnated, paper-based sheathing membranes shall be used.

Technical information

This evaluation is based on demonstrated conformance with the following criteria:

Criteria number	Criteria name
CCMC-TG-074645.01-15	CCMC Technical Guide for Cellulose Reinforced Fibre Cement Cladding

The evaluation holder has submitted technical documentation for the CCMC evaluation. Testing was conducted at laboratories recognized by CCMC. The corresponding technical evidence for this product is summarized below.

General

Dimensional tolerances

Table 1. Results of testing the dimensional measurements of HardiePanel® HZ5™ Vertical Siding

Property	Unit	Requirement	Result
Length	mm	±3.0	2
Width	mm	±3.0	2
Thickness	mm	±1.6	0.51
Squareness	mm/m	±4.0	1.33
Edge straightness	mm/m	±2.6	0.73

Table 2. Results of testing the dimensional measurements of Artisan® Lap Siding

Property	Unit	Requirement	Result
Length	mm	±3.0	2.2
Width	mm	±3.0	-1.3
Thickness	mm	±1.6	0.3
Squareness	mm/m	±4.0	0.0
Edge straightness	mm/m	±2.6	0.0

Table 3. Results of testing the dimensional measurements of Artisan® Siding with Lock Joint System

Property	Unit	Requirement	Result
Length	mm	±3.0	-2.8
Width	mm	±3.0	0.3
Thickness	mm	±1.6	0.1
Squareness	mm/m	±4.0	0.0
Edge straightness	mm/m	±2.6	0.0

Prescriptive requirements

Table 4. Results of testing the prescriptive requirements of HardiePanel® HZ5™ Vertical Siding

Property		Unit	Requirement	Result	
Water absorption		%	≤ 40	29.8	
Density		kg/m ³	≥ 950	1 388	
Dimensional change		%	< 0.20	0.1	
Flexural strength	MD ⁽¹⁾	MPa	> 7.0	21.0	
	XD ⁽¹⁾		> 7.0	13.7	
Fastener pull-through resistance		N	≥ 28 × thickness	1 144	
Water vapour transmission (water method)		ng/m ² -s-Pa	> 60	1 056	
Freeze-thaw resistance	loss of mass		%	≤ 3	1.42
	loss of flexural strength	MD	%	≤ 15	4.1
		XD	%	≤ 15	12.9
	deleterious effects		-	None	None
Watertightness		-	No drop of water	None	
Warm water resistance	loss of flexural strength	MD	%	≤ 15	-9.4 ⁽²⁾
		XD	%	≤ 15	-12.0 ⁽²⁾
	deleterious effects		-	No visible cracks	None

Notes:

- 1 “MD” refers to machine direction; “XD” refers to cross-machine direction
- 2 The negative values indicate that they gained strength after the warm water resistance test.

Table 5. Results of testing the prescriptive requirements of Artisan® Lap Siding

Property		Unit	Requirement	Result
Water absorption		%	≤ 40	29.0
Density		kg/m ³	≥ 950	1 205
Flexural strength	MD ⁽¹⁾	MPa	> 7.0	17.5
	XD ⁽¹⁾		> 7.0	11.0
Water vapour transmission	water method	ng/m ² ·s·Pa	> 60	668
	desiccant method		Report value	320

Note:

¹ “MD” refers to machine direction; “XD” refers to cross-machine direction.

Table 6. Results of testing the prescriptive requirements of Artisan® Siding with Lock Joint System

Property		Unit	Requirement	Result
Water absorption		%	≤ 40	30.0
Density		kg/m ³	≥ 950	1 221
Flexural strength	MD ⁽¹⁾	MPa	> 7.0	15.0
	XD ⁽¹⁾		> 7.0	8.6
Water vapour transmission	water method	ng/m ² ·s·Pa	> 60	602
	desiccant method		Report value	315
Freeze-thaw resistance	loss of mass	%	≤ 3	2.00
	loss of flexural strength	%	≤ 15	3.0
	deleterious effects	-	None	None

Note:

¹ “MD” refers to machine direction; “XD” refers to cross-machine direction.

Performance requirements

Wind load resistance

This PDF is an alternative version. This document was published on 2022-11-22 and may not be the latest version of this evaluation. Users should consult the latest [published assessment](#) on the [CCMC Registry of Product Assessments](#), which contains the most up to date information. This PDF is intended for use as a record, not the latest information available.

Table 7. Results of testing the wind load resistance of the products for non-post-disaster buildings

Assembly ID ⁽¹⁾	Product	Cladding dimension, mm	Frame	Sheathing	Stud spacing ⁽²⁾ , mm	Fastener spacing, mm	Fasteners	Maximum building height ⁽³⁾ , m	Hourly wind pressure, Q ₅₀ , kPa
1	HardiePanel® HZ5™ Vertical Siding	1 220 × 2 440 × 7.5	2 × 4 spruce-pine-fir (S-P-F) wood	None	610	305 (vertical)	6d common nail	12	Q ₅₀ < 0.55
								20	Q ₅₀ < 0.45
2		1 220 × 2 440 × 7.5	2 × 4 S-P-F wood	None	610	203 (vertical)	50-mm siding nail; 2.3-mm shank; 5.7-mm head	12	Q ₅₀ < 0.55
								20	Q ₅₀ < 0.45
3		1 220 × 2 440 × 7.5	2 × 4 S-P-F wood	None	610	150 (vertical)	6d common nail	12	Q ₅₀ < 0.75
								20	Q ₅₀ < 0.65
4		1 220 × 2 440 × 7.5	2 × 4 S-P-F wood	None	610	150 (vertical)	38-mm ring shank nail; 2.5-mm shank; 5.7-mm head	12	Q ₅₀ < 0.55
								20	Q ₅₀ < 0.45
5		1 220 × 2 440 × 7.5	20-ga steel	None	610	305 (vertical)	#8 bugle head screw; 32-mm long; 8.2-mm head	12	Q ₅₀ < 0.45

This PDF is an alternative version. This document was published on 2022-11-22 and may not be the latest version of this evaluation. Users should consult the latest [published assessment](#) on the [CCMC Registry of Product Assessments](#), which contains the most up to date information. This PDF is intended for use as a record, not the latest information available.

Assembly ID ⁽¹⁾	Product	Cladding dimension, mm	Frame	Sheathing	Stud spacing ⁽²⁾ , mm	Fastener spacing, mm	Fasteners	Maximum building height ⁽³⁾ , m	Hourly wind pressure, Q ₅₀ , kPa
6		1 220 × 2 440 × 7.5	20-ga steel	None	610	305 (vertical)	38-mm ET&F pin; 2.5-mm shank; 6.2-mm head	-	Fail ⁽⁴⁾
7		1 220 × 2 440 × 7.5	20-ga steel	None	610	203 (vertical)	38-mm ET&F pin; 2.5-mm shank; 6.2-mm head	12 20	Q ₅₀ < 0.55 Q ₅₀ < 0.45
8	HardiePanel® HZ5™ Vertical Siding	1 220 × 2 440 × 7.5	18-ga steel	None	406	150 (vertical)	38-mm ET&F pin; 2.5-mm shank; 6.2-mm head	12 20	Q ₅₀ < 0.75 Q ₅₀ < 0.65
9		HardiePlank® HZ5™ Lap Siding	235 × 305 × 7.5	2 × 4 S-P-F wood	None	406	-	(blind nailing) ⁽⁵⁾ 6d common nail	12 20
10	235 × 305 × 7.5		2 × 4 S-P-F wood	None	610	-	(blind nailing) 6d common nail	12 20	Q ₅₀ < 0.55 Q ₅₀ < 0.45

This PDF is an alternative version. This document was published on 2022-11-22 and may not be the latest version of this evaluation. Users should consult the latest [published assessment](#) on the [CCMC Registry of Product Assessments](#), which contains the most up to date information. This PDF is intended for use as a record, not the latest information available.

Assembly ID ⁽¹⁾	Product	Cladding dimension, mm	Frame	Sheathing	Stud spacing ⁽²⁾ , mm	Fastener spacing, mm	Fasteners	Maximum building height ⁽³⁾ , m	Hourly wind pressure, Q ₅₀ , kPa
11		235 × 305 × 7.5	2 × 4 S-P-F wood	None	406	-	(blind nailing)	12	Q ₅₀ < 0.75
							32-mm roofing nail; 3-mm shank; 9.5-mm head	20	Q ₅₀ < 0.65
12		235 × 305 × 7.5	2 × 4 S-P-F wood	None	610	-	(blind nailing) 50-mm siding nail; 2.3-mm shank; 5.6-mm head	12	Q ₅₀ < 0.55
13	HardiePlank® HZ5™ Lap Siding	305 × 305 × 7.5	2 × 4 S-P-F wood	None	406	-	(face nailing) ⁽⁶⁾	12	Q ₅₀ < 0.65
							63.5-mm siding nail; 2.4-mm shank; 6.0-mm head	20	Q ₅₀ < 0.55
14		235 × 305 × 7.5	2 × 4 S-P-F wood	None	610	-	(face nailing) 6d common nail	12	Q ₅₀ < 0.75
								20	Q ₅₀ < 0.65

This PDF is an alternative version. This document was published on 2022-11-22 and may not be the latest version of this evaluation. Users should consult the latest [published assessment](#) on the [CCMC Registry of Product Assessments](#), which contains the most up to date information. This PDF is intended for use as a record, not the latest information available.

Assembly ID ⁽¹⁾	Product	Cladding dimension, mm	Frame	Sheathing	Stud spacing ⁽²⁾ , mm	Fastener spacing, mm	Fasteners	Maximum building height ⁽³⁾ , m	Hourly wind pressure, Q ₅₀ , kPa
15		235 × 305 × 7.5	2 × 4 S-P-F wood	11.1-mm oriented strandboard (OSB)	610	203 (horizontal)	(blind nailing)	12	Q ₅₀ < 0.55
							32-mm ring shank nail; 2.4-mm shank; 5.6-mm head	20	Q ₅₀ < 0.45
16		184 × 305 × 7.5	2 × 4 S-P-F wood	None	406	-	(blind nailing)	12	Q ₅₀ < 0.75
							6d common nail	20	Q ₅₀ < 0.65
17		235 × 305 × 7.5	2 × 4 S-P-F wood	None	406	-	(blind nailing)	12	Q ₅₀ < 0.55
							32-mm ring shank nail; 2.4-mm. shank; 5.6-mm head	20	Q ₅₀ < 0.45
18		235 × 305 × 7.5	2 × 4 S-P-F wood	None	610	-	(blind nailing) 32-mm ring shank nail; 2.4-mm. shank; 5.6-mm head	12	Q ₅₀ < 0.45

This PDF is an alternative version. This document was published on 2022-11-22 and may not be the latest version of this evaluation. Users should consult the latest [published assessment](#) on the [CCMC Registry of Product Assessments](#), which contains the most up to date information. This PDF is intended for use as a record, not the latest information available.

Assembly ID ⁽¹⁾	Product	Cladding dimension, mm	Frame	Sheathing	Stud spacing ⁽²⁾ , mm	Fastener spacing, mm	Fasteners	Maximum building height ⁽³⁾ , m	Hourly wind pressure, Q ₅₀ , kPa
19		210 × 305 × 7.5	20-ga steel	None	406	-	(blind nailing)	12	Q ₅₀ < 0.55
							38-mm ET&F pin; 2.5-mm shank; 6.2-mm head	20	Q ₅₀ < 0.45
20	HardieShingle® HZ5™ Notched Panels	406 × 1 220 × 6.2	2 × 4 S-P-F wood	None	610	-	(blind nailing)	12	Q ₅₀ < 0.55
							32-mm ring shank nail; 2.4-mm shank; 5.6-mm head	20	Q ₅₀ < 0.45
21		406 × 1 220 × 6.2	2 × 4 S-P-F wood	None	406	-	(blind nailing)	12	Q ₅₀ < 0.75
							32-mm ring shank nail; 2.4-mm shank; 5.6-mm head	20	Q ₅₀ < 0.65

This PDF is an alternative version. This document was published on 2022-11-22 and may not be the latest version of this evaluation. Users should consult the latest [published assessment](#) on the [CCMC Registry of Product Assessments](#), which contains the most up to date information. This PDF is intended for use as a record, not the latest information available.

Assembly ID ⁽¹⁾	Product	Cladding dimension, mm	Frame	Sheathing	Stud spacing ⁽²⁾ , mm	Fastener spacing, mm	Fasteners	Maximum building height ⁽³⁾ , m	Hourly wind pressure, Q ₅₀ , kPa
22		406 × 1 220 × 6.2	2 × 4 S-P-F wood	11.1-mm OSB	610	356 (horizontal)	(blind nailing)	12	Q ₅₀ < 0.55
							32-mm ring shank nail; 2.4-mm shank; 5.6-mm head	20	Q ₅₀ < 0.45
23	HardieShingle® HZ5™ Notched Panels	406 × 1 220 × 6.2	20-ga steel	None	610	-	(blind nailing)	12	Q ₅₀ < 0.55
							38-mm ET&F pin; 2.5-mm shank; 6.2-mm head	20	Q ₅₀ < 0.45
24		406 × 1 220 × 6.2	2 × 4 S-P-F wood	None	406	-	(blind nailing)	12	Q ₅₀ < 0.75
							32-mm roofing nail; 3.0-mm shank; 9.5-mm head	20	Q ₅₀ < 0.65

This PDF is an alternative version. This document was published on 2022-11-22 and may not be the latest version of this evaluation. Users should consult the latest [published assessment](#) on the [CCMC Registry of Product Assessments](#), which contains the most up to date information. This PDF is intended for use as a record, not the latest information available.

Assembly ID ⁽¹⁾	Product	Cladding dimension, mm	Frame	Sheathing	Stud spacing ⁽²⁾ , mm	Fastener spacing, mm	Fasteners	Maximum building height ⁽³⁾ , m	Hourly wind pressure, Q ₅₀ , kPa
25	HardieShingle® HZ5™ Individual Shingle	150, 203, 305 × 457 × 6.2	2 × 4 S-P-F wood	11.1-mm OSB	610	Two end nails per shingle ⁽⁷⁾	(blind nailing)	12	Q ₅₀ < 0.75
							32-mm roofing nail; 3.0-mm shank; 9.5-mm head	20	Q ₅₀ < 0.65
26		150, 203, 305 × 457 × 6.2	2 × 4 S-P-F wood	11.1-mm OSB	610	Two end nails per shingle	(blind nailing)	12	Q ₅₀ < 0.75
							32-mm ring shank nail; 2.4-mm shank; 5.6-mm head	20	Q ₅₀ < 0.65
27 ⁽⁸⁾	Artisan® Siding with Lock Joint System	260 × 3 660 × 16	2 × 4 S-P-F wood	None	406	-	(blind nailing)	12	Q ₅₀ < 0.85
							6d siding nail; 50.4-mm long; 2.4-mm shank; 5.6-mm head	20	Q ₅₀ < 0.75

This PDF is an alternative version. This document was published on 2022-11-22 and may not be the latest version of this evaluation. Users should consult the latest [published assessment](#) on the [CCMC Registry of Product Assessments](#), which contains the most up to date information. This PDF is intended for use as a record, not the latest information available.

Assembly ID ⁽¹⁾	Product	Cladding dimension, mm	Frame	Sheathing	Stud spacing ⁽²⁾ , mm	Fastener spacing, mm	Fasteners	Maximum building height ⁽³⁾ , m	Hourly wind pressure, Q ₅₀ , kPa
28		260 × 3 660 × 16	2 × 4 S-P-F wood + 1 × 4 S-P-F furring	None	406	-	(blind nailing) #8 screw; 9.5-mm head-diameter; 32-mm long	12	Q ₅₀ < 1.00
								20	Q ₅₀ < 1.00
29	Artisan® Siding with Lock Joint System	260 × 3 660 × 16	2 × 4 S-P-F wood + 1 × 4 S-P-F furring	None	610	-	(blind nailing) #8 screw; 9.5-mm head-diameter; 32-mm long	12	Q ₅₀ < 0.85
								20	Q ₅₀ < 0.75
30 ⁽⁸⁾		260 × 3 660 × 16	20-ga steel	None	406	-	(blind nailing) #8 screw; 9.5-mm head-diameter; 32-mm long	12	Q ₅₀ < 1.00
								20	Q ₅₀ < 1.00

This PDF is an alternative version. This document was published on 2022-11-22 and may not be the latest version of this evaluation. Users should consult the latest [published assessment](#) on the [CCMC Registry of Product Assessments](#), which contains the most up to date information. This PDF is intended for use as a record, not the latest information available.

Assembly ID ⁽¹⁾	Product	Cladding dimension, mm	Frame	Sheathing	Stud spacing ⁽²⁾ , mm	Fastener spacing, mm	Fasteners	Maximum building height ⁽³⁾ , m	Hourly wind pressure, Q ₅₀ , kPa
31 ⁽⁸⁾	Artisan® Siding with Lock Joint System	260 × 3 660 × 16	2 × 4 Douglas Fir Larch wood	None	610	-	(face nailing)	12	Q ₅₀ < 1.00
							8d ring shank siding nail; 50.4-mm long; 2.4-mm shank; 5.6-mm head	20	Q ₅₀ < 1.00
32	Artisan® Lap Siding	209 × 3 660 × 16	2 × 4 S-P-F wood	None	406	-	(blind nailing)	12	Q ₅₀ < 0.85
							6d siding nail; 50.4-mm long; 2.4-mm shank; 5.6-mm head	20	Q ₅₀ < 0.75
33		209 × 3 660 × 16	20-ga steel	None	406	-	(blind nailing)	12	Q ₅₀ < 1.00
							#8 screw; 7.9-mm head-diameter; 41-mm long	20	Q ₅₀ < 1.00

Notes:

This PDF is an alternative version. This document was published on 2022-11-22 and may not be the latest version of this evaluation. Users should consult the latest [published assessment](#) on the [CCMC Registry of Product Assessments](#), which contains the most up to date information. This PDF is intended for use as a record, not the latest information available.

-
- 1 Some of the assemblies and fastening schedules listed in the table are not covered by the manufacturer's installation instructions.
 - 2 Stud spacing indicates the horizontal fastener spacing when no sheathing was used. When sheathing was used, the horizontal fastener spacing is shown in the table.
 - 3 Buildings up to three storeys high (12 m) fall under the scope of Part 9 of Division B of the NBC 2015. Buildings higher than 12 m fall under the scope of Part 4 of Division B of the NBC 2015. In accordance with the NBC 2015, the engineering design must be prepared by a professional engineer licensed to practise in Canada who has expertise in the relevant area.
 - 4 The testing lab indicated that the test failed due to the poor installation of the panel on the structure.
 - 5 Blind nailing is a technique in which siding is fastened only at the top by penetrating through one sheet, and fasteners are hidden by the course above.
 - 6 Face nailing is a technique in which siding is fastened at the top and the bottom by penetrating through two sheets of overlapped siding, and fastener heads are exposed to the elements.
 - 7 A fastener was nailed at the side ends of the siding on the sheathing.
 - 8 Under this Evaluation Report, the performance of Artisan[®] Siding with Lock Joint System has only been validated when it is installed with drained and vented air space not less than 10 mm deep behind the cladding. Therefore, the data provided in this table for Assembly IDs 27, 30 and 31 are presented for information only. Please refer to Intertek test report# 103764372COQ-008 dated 2019-12-20 for further information.
-

Table 8. Deflection measurements from the wind load resistance test

Assembly ID	Maximum wind pressure for deflection measurements, Pa	Deflection measurements, mm			
		Assembly ⁽¹⁾		Component ⁽²⁾	
		Negative pressure	Positive pressure	Negative pressure	Positive pressure
1	980	-5.37	5.00	-2.39	2.23
2	1 200	-4.93	4.41	-2.20	1.97
3	1 630	-4.90	4.77	-2.19	2.12
4	980	-3.27	3.18	-1.46	1.35
5	1 200	-4.12	4.04	-2.14	2.05
6	1 200	N/A ⁽³⁾	N/A ⁽³⁾	N/A ⁽³⁾	N/A ⁽³⁾
7	1 200	-4.89	4.79	-2.54	2.40
8	1 200	-2.13	2.05	0.57	0.50
9	1 630	-5.02	4.99	-0.72	0.65
10	1 200	-6.19	5.85	-2.30	2.17
11	1 200	-5.49	5.47	-0.78	0.71
12	1 200	-5.99	5.87	-2.22	2.09
13	1 200	-4.05	3.89	-2.96	2.84
14	1 630	-7.17	6.30	-3.47	3.05
15	1 200	-4.76	4.05	-1.55	0.42
16	1 630	-5.61	5.35	-0.80	0.76
17	1 200	-3.99	3.71	-0.57	0.53
18	980	-5.17	4.73	-1.92	1.73
19	1 200	-3.76	3.44	-0.63	0.59
20	1 200	-2.70	2.64	-1.09	1.02
21	1 630	-2.31	2.27	-0.36	0.28
22	1 200	-2.31	2.19	-0.82	0.75
23	1 200	-3.20	2.95	-1.51	1.39
24	1 630	-2.31	2.24	-0.36	0.31
25	1 630	-6.21	6.09	0.31	0.26
26	1 630	-6.66	5.98	-0.33	0.30

This PDF is an alternative version. This document was published on 2022-11-22 and may not be the latest version of this evaluation. Users should consult the latest [published assessment](#) on the [CCMC Registry of Product Assessments](#), which contains the most up to date information. This PDF is intended for use as a record, not the latest information available.

Assembly ID	Maximum wind pressure for deflection measurements, Pa	Deflection measurements, mm			
		Assembly ⁽¹⁾		Component ⁽²⁾	
		Negative pressure	Positive pressure	Negative pressure	Positive pressure
27 ⁽⁴⁾	1 850	-38.69	39.41	-39.02	37.11
28	2 660	-44.42	49.86	-38.48	49.00
29	1 850	-41.56	46.48	-47.98	46.32
30 ⁽⁴⁾	2 410	-37.78	36.55	-38.40	37.00
31 ⁽⁴⁾	2 660	-63.72	51.92	-65.55	52.20
32	1 850	-29.98	-37.08	-30.95	37.42
33	2 410	-14.53	-19.13	-14.71	19.25

Notes:

- 1 The deflection was measured at the mid-height of a 3 000-mm stud and determined with the averaged deflections at the bottom and the top of the stud as a baseline.
- 2 The deflection was measured at the centre point between two studs and determined with the averaged deflections at those studs as a baseline.
- 3 "N/A" = not applicable. The deflection was not measured due to the failure of the specimen.
- 4 Under this Evaluation Report, the performance of Artisan[®] Siding with Lock Joint System has only been validated when it is installed with drained and vented air space not less than 10 mm deep behind the cladding. Therefore, the data provided in this table for Assembly IDs 27, 30 and 31 are presented for information only. Please refer to Intertek test report# 103764372COQ-008 dated 2019-12-20 for further information.

Table 9. Results of testing the impact resistance ⁽¹⁾ of the products

Assembly ID	Safety impact		Retention of performance				
	Large soft 100 N·m	Small hard 10 N·m	Large soft 34 N·m	Smaller soft 60 N·m	Smaller soft 6 N·m	Small hard 10 N·m	Small hard 1 N·m
1	Pass	Pass	Pass	Pass	Pass	Pass	Pass
2	Pass	Pass	Pass	Pass	Pass	Pass	Pass
3	Pass	Pass	Pass	Fail ⁽²⁾	Pass	Pass	Pass
4	Pass	Pass	Pass	Fail ⁽²⁾	Pass	Pass	Pass
5	Pass	Pass	Pass	Pass	Pass	Pass	Pass
6	N/A ⁽³⁾	N/A ⁽³⁾	N/A ⁽³⁾	N/A ⁽³⁾	N/A ⁽³⁾	N/A ⁽³⁾	N/A ⁽³⁾
7	Pass	Pass	Pass	Fail ⁽²⁾	Pass	Pass	Pass
8	Pass	Pass	Pass	Fail ⁽²⁾	Pass	Pass	Pass
9	Pass	Pass	Pass	Fail ⁽²⁾	Pass	Pass	Pass
10	Pass	Pass	Pass	Fail ⁽²⁾	Pass	Pass	Pass
11	Pass	Pass	Pass	Fail ⁽²⁾	Pass	Pass	Pass
12	Pass	Pass	Pass	Fail ⁽²⁾	Pass	Pass	Pass
13	Pass	Pass	Pass	Fail ⁽²⁾	Pass	Pass	Pass
14	Pass	Pass	Pass	Fail ⁽²⁾	Pass	Pass	Pass
15	Pass	Pass	Pass	Pass	Pass	Pass	Pass
16	Pass	Pass	Pass	Fail ⁽²⁾	Pass	Pass	Pass
17	Pass	Pass	Pass	Fail ⁽²⁾	Pass	Pass	Pass
18	Pass	Pass	Pass	Fail ⁽²⁾	Pass	Pass	Pass
19	Pass	Pass	Pass	Fail ⁽²⁾	Pass	Pass	Pass
20	Pass	Pass	Pass	Fail ⁽²⁾	Pass	Pass	Pass
21	Pass	Pass	Pass	Fail ⁽²⁾	Pass	Pass	Pass
22	Pass	Pass	Pass	Fail ⁽²⁾	Pass	Pass	Pass
23	Pass	Pass	Pass	Fail ⁽²⁾	Pass	Pass	Pass
24	Pass	Pass	Pass	Fail ⁽²⁾	Pass	Pass	Pass
25	Pass	Pass	Pass	Fail ⁽²⁾	Pass	Fail ⁽²⁾	Pass
26	Pass	Pass	Pass	Fail ⁽²⁾	Pass	Fail ⁽²⁾	Pass
27 ⁽⁴⁾	Pass	Fail ⁽²⁾	Pass	Fail ⁽²⁾	-	Fail ⁽²⁾	-

This PDF is an alternative version. This document was published on 2022-11-22 and may not be the latest version of this evaluation. Users should consult the latest [published assessment](#) on the [CCMC Registry of Product Assessments](#), which contains the most up to date information. This PDF is intended for use as a record, not the latest information available.

Assembly ID	Safety impact		Retention of performance				
	Large soft 100 N·m	Small hard 10 N·m	Large soft 34 N·m	Smaller soft 60 N·m	Smaller soft 6 N·m	Small hard 10 N·m	Small hard 1 N·m
28	Pass	Fail ⁽²⁾	Pass	Fail ⁽²⁾	-	Pass	-
29	Pass	Pass	Pass	Fail ⁽²⁾	-	Pass	-
30 ⁽⁴⁾	Pass	Fail ⁽²⁾	Pass	Fail ⁽²⁾	-	Fail ⁽²⁾	-
31 ⁽⁴⁾	Pass	Pass	Pass	Pass	-	Pass	-
32	Pass	Pass	Pass	Pass	-	Pass	-
33	Pass	Pass	Pass	Pass	-	Pass	-

Notes:

- 1 Large soft bodies are designed to transfer a significant amount of energy to the cladding and to the wall assembly. Small hard bodies are capable of causing localized impact damage without any appreciable transmission of energy to the wall assembly. Smaller soft bodies are smaller and harder than the large soft bodies, and larger and softer than small hard bodies. They are designed to induce localized damage, as well as transmit energy to the rest of the assembly.
- 2 The product did not demonstrate capacity to retain the performance of the cladding under impact loads that induce localized damage as well as transmit energy to the rest of the assembly. The product will be limited to applications where such performance is not required or where the cladding system can be repaired or replaced easily. The CCMC Technical Guide specifies that for cladding systems that can be repaired or replaced easily, lower impact resistance values may be accepted down to 6 N·m for small soft impact and 1 N·m for small hard impact.
- 3 N/A = not applicable. Assembly 6 was not tested for impact resistance because it previously failed the wind resistance test.
- 4 Under this evaluation report, the performance of Artisan® Siding with Lock Joint System has only been validated when it is installed with drained and vented air space not less than 10 mm deep behind the cladding. Therefore, the data provided in this table for Assembly# 27, 30 and 31 is presented for information only. Please refer to Intertek test report# 103764372COQ-008 dated 2019-12-20 for further information.

Fire performance

Table 10. Results of testing the fire performance ⁽¹⁾

Property	Requirement	Result
Non-combustibility	CAN/ULC-S114	Non-combustible
Flame-spread rating	CAN/ULC-S102	0
Smoke-developed classification		5

This PDF is an alternative version. This document was published on 2022-11-22 and may not be the latest version of this evaluation. Users should consult the latest [published assessment](#) on the [CCMC Registry of Product Assessments](#), which contains the most up to date information. This PDF is intended for use as a record, not the latest information available.

Note:

¹ Based on the Intertek listing information (SPEC ID: 29928) of HardiePanel® HZ5™ Vertical Siding.

Administrative information

Disclaimer

This evaluation is issued by the Canadian Construction Materials Centre (CCMC), a part of the Construction Research Centre at the National Research Council of Canada (NRC). The evaluation must be read in the context of the entire [CCMC Registry of Product Assessments](#) and the legislated applicable building code in effect.

The CCMC was established in 1988 on behalf of the applicable regulator (i.e., the provinces and territories) to ensure—through assessment—conformity of alternative and acceptable solutions to regional building codes as determined by the local authority having jurisdiction (AHJ) as part of the issuance of a building permit.

It is the responsibility of the local AHJs, design professionals, and specifiers to confirm that the evaluation is current and has not been withdrawn or superseded by a later issue. Please refer to [the website](#) or contact:

Canadian Construction Materials Centre

Construction Research Centre
National Research Council of Canada
1200 Montreal Road
Ottawa, Ontario, K1A 0R6
Telephone: 613-993-6189
Fax: 613-952-0268

The NRC has evaluated the material, product, system or service described herein only for those characteristics stated herein. The information and opinions in this evaluation are directed to those who have the appropriate degree of experience to use and apply its contents (i.e., AHJs, design professionals and specifiers). This evaluation is only valid when the product is installed in strict compliance with the stated conditions and limitations of evaluation and the applicable local building code. In circumstances where no applicable local building permit is issued and that no confirmation of compliance 'for use in the intended field application' is undertaken, this evaluation is null and void in all respects. This evaluation is provided without representation, warranty, or guarantee of any kind, expressed, or implied, and the NRC provides no endorsement for any evaluated material, product, system or service described herein. The NRC accepts no responsibility whatsoever arising in any way from any and all use and reliance on the information contained in this evaluation with respect to its compliance to the referenced code(s) and standard(s). The NRC is not undertaking to render professional or other services on behalf of any person or entity nor to perform any duty owed by any person or entity to another person or entity.

Language

Une version française de ce document est disponible.

In the case of any discrepancy between the English and French version of this document, the English version shall prevail.

Copyright

© His Majesty the King in Right of Canada, as represented by the National Research Council of Canada, 2022

All rights reserved. No part of this publication may be reproduced, stored in a retrieval system, or transmitted in any form or by any means, electronic, mechanical, photocopying, recording or otherwise, without the prior written permission of the CCMC.

This PDF is an alternative version. This document was published on 2022-11-22 and may not be the latest version of this evaluation. Users should consult the latest [published assessment](#) on the [CCMC Registry of Product Assessments](#), which contains the most up to date information. This PDF is intended for use as a record, not the latest information available.

CCMC recognition

The Canadian Construction Materials Centre (CCMC) assesses compliance with Canadian building, energy and safety codes. We are the only construction code compliance service supported and operated by the Government of Canada. Trusted by over 6,000 regulators across Canada.

Most Canadian authorities having jurisdiction (AHJs) consider CCMC product assessments acceptable as evidence for product approval.

CCMC assessments are recognized by construction authorities across Canada:

Alliance of Canadian Building Official Associations (ACBOA)



[\(Alliance of Canadian Building Official Associations \(ACBOA\)\)](#)

First Nations National Building Officers Association (FNNBOA)



[\(First Nations National Building Officers Association \(FNNBOA\)\)](#)

Canadian Home Builders' Association (CHBA)



[\(Canadian Home Builders' Association \(CHBA\)\)](#)

Alberta Building Officials Association (ABOA)



[\(Alberta Building Officials Associations \(ABOA\)\)](#)

Saskatchewan Building Officials Association (SBOA)



[\(Saskatchewan Building Officials Association \(SBOA\)\)](#)

Manitoba Building Officials Association (MBOA)



[\(Manitoba Building Officials Association \(MBOA\)\)](#)

Ontario Building Officials Association (OBOA)



[\(Ontario Building Officials Association \(OBOA\)\)](#)

New Brunswick Building Officials Association (NBBOA)



[\(New Brunswick Building Officials Association \(NBBOA\)\)](#)

Nova Scotia Building Officials Association (NSBOA)



[\(Nova Scotia Building Officials Association \(NSBOA\)\)](#)

The CCMC provides code compliance assessments to Canadian code requirements, consulting nationwide with construction regulators to elicit regional variations in code requirements as well as provincial and local interpretations. Users are advised to review the technical information presented in CCMC assessments when making approval decisions. [Learn more about how the CCMC provides a unique service for Canada.](#)

For more information, contact the CCMC by phone at (613) 993-6189 or by email at ccmc@nrc-cnrc.gc.ca

Code compliance as an acceptable solution

Code Compliance via Acceptable Solutions

If a building design (e.g. material, component, assembly or system) can be shown to meet all provisions of the applicable **acceptable solutions** in Division B (e.g. it complies with the applicable provisions of a referenced standard), it is deemed to have satisfied the objectives and functional statements linked to those provisions and thus to have complied with that part of the Code.

— National Building Code of Canada, Sentence A-1.2.1.1.(1)(a)

The CCMC has determined that compliance with this provision of the Code has been demonstrated as an **Acceptable Solution**. The evaluation report provides a summary of the basis of CCMC's compliance opinion.

CCMC's code compliance opinions

All CCMC evaluation reports are opinions of code compliance established in accordance with the National Building Code of Canada, Subsection 1.2.1. "Compliance with this Code," which requires compliance to be achieved by:

- complying with the applicable acceptable solutions in Division B, or
- using an alternative solution that will achieve at least the minimum level of performance required by Division B in the areas defined by the objective and functional statements attributed to the applicable acceptable solutions.

The CCMC assesses compliance with Canadian building, energy and safety codes, and is trusted by over 6,000 regulators across Canada.

Code compliance as an alternative solution

Code Compliance via Alternative Solutions

Where a design differs from the acceptable solutions in Division B, then it should be treated as an **"alternative solution."** A proponent of an alternative solution must demonstrate that the alternative solution addresses the same issues as the applicable acceptable solutions in Division B and their attributed objectives and functional statements. However, because the objectives and functional statements are entirely qualitative, demonstrating compliance with them in isolation is not possible. Therefore, Clause 1.2.1.1.(1)(b) identifies the principle that Division B establishes the quantitative performance targets that alternative solutions must meet. In many cases, these targets are not defined very precisely by the acceptable solutions [...] Nevertheless, Clause 1.2.1.1.(1)(b) makes it clear that an effort must be made to demonstrate that an alternative solution will perform as well as a design that would satisfy the applicable acceptable solutions in Division B—not “well enough” but “as well as.”

— National Building Code of Canada, Sentence A-1.2.1.1.(1)(b)

The CCMC has determined that compliance with this provision of the Code has been demonstrated as an **Alternative Solution**. The evaluation report provides a summary of the basis of CCMC's compliance opinion.

CCMC's code compliance opinions

All CCMC evaluation reports are opinions of code compliance established in accordance with the National Building Code of Canada, Subsection 1.2.1. "Compliance with this Code," which requires compliance to be achieved by:

- complying with the applicable acceptable solutions in Division B, or
- using an alternative solution that will achieve at least the minimum level of performance required by Division B in the areas defined by the objective and functional statements attributed to the applicable acceptable solutions.

The CCMC assesses compliance with Canadian building, energy and safety codes, and is trusted by over 6,000 regulators across Canada.