



HardiePanel® Vertical Siding

SINGLE FAMILY INSTALLATION REQUIREMENTS

EFFECTIVE SEPTEMBER 2019

IMPORTANT: FAILURE TO FOLLOW JAMES HARDIE WRITTEN INSTALLATION INSTRUCTIONS AND COMPLY WITH APPLICABLE BUILDING CODES MAY VIOLATE LOCAL LAWS, AFFECT BUILDING ENVELOPE PERFORMANCE AND MAY AFFECT WARRANTY COVERAGE. FAILURE TO COMPLY WITH ALL HEALTH AND SAFETY REGULATIONS WHEN CUTTING AND INSTALLING THIS PRODUCT MAY RESULT IN PERSONAL INJURY. BEFORE INSTALLATION, CONFIRM YOU ARE USING THE CORRECT HARDIEZONE® PRODUCT INSTRUCTIONS BY VISITING HARDIEZONE.COM OR CALL 1-866-942-7343 (866-9-HARDIE)

STORAGE & HANDLING:

Store flat and keep dry and covered prior to installation. Installing siding wet or saturated may result in shrinkage at butt joints. Carry planks on edge. Protect edges and corners from breakage. James Hardie is not responsible for damage caused by improper storage and handling of the product.



CUTTING INSTRUCTIONS

OUTDOORS

- Position cutting station so that airflow blows dust away from the user and others near the cutting area.
- Cut using one of the following methods:
 - Best:** Circular saw equipped with a HardieBlade® saw blade and attached vacuum dust collection system. Shears (manual, pneumatic or electric) may also be used, not recommended for products thicker than 7/16 in.
 - Better:** Circular saw equipped with a dust collection feature (e.g. Roan® saw) and a HardieBlade saw blade.
 - Good:** Circular saw equipped with a HardieBlade saw blade.

INDOORS

DO NOT grind or cut with a power saw indoors. Cut using shears (manual, pneumatic or electric) or the score and snap method, not recommended for products thicker than 7/16 in.

- DO NOT dry sweep dust; use wet dust suppression or vacuum to collect dust.
- For maximum dust reduction, James Hardie recommends using the "Best" cutting practices. Always follow the equipment manufacturer's instructions for proper operation.
- For best performance when cutting with a circular saw, James Hardie recommends using HardieBlade® saw blades.
- Go to jameshardiepros.com for additional cutting and dust control recommendations.

IMPORTANT: The Occupational Safety and Health Administration (OSHA) regulates workplace exposure to silica dust. For construction sites, OSHA has deemed that cutting fiber cement with a circular saw having a blade diameter less than 8 inches and connected to a commercially available dust collection system per manufacturer's instructions results in exposures below the OSHA Permissible Exposure Limit (PEL) for respirable crystalline silica, without the need for additional respiratory protection.

If you are unsure about how to comply with OSHA silica dust regulations, consult a qualified industrial hygienist or safety professional, or contact your James Hardie technical sales representative for assistance. James Hardie makes no representation or warranty that adopting a particular cutting practice will assure your compliance with OSHA rules or other applicable laws and safety requirements.

GENERAL REQUIREMENTS:

- These instructions to be used for single family installations only. **For Commercial / Multi-Family installation requirements go to www.JamesHardiePros.com
- References to the 2015 National Building Code (NBC) of Canada are made throughout this document. Local building code requirements may supersede the NBC in some locations.
- Where local building code requires a capillary break (Rainscreens, Furring, etc.), fastener specifications per the CCMC can still be used as long as the required fastener penetration is achieved into an approved nailable substrate.
- HardiePanel® siding can be installed over furring strips (in accordance with local building code requirements).
- HardiePanel vertical siding can be installed over braced wood or steel studs, 20 gauge (0.836 mm) minimum to 16 gauge (1.367 mm) maximum, spaced a maximum of 610mm (24 in) o.c. Irregularities in framing and sheathing can mirror through the finished application. Refer to the table on page 3 of this document and 'Fastener Requirements' for specific arrangement and type of fasteners for your application.
- Information on installing James Hardie products over non-nailable substrates (ex: gypsum, foam, etc.) can be located in JH Tech Bulletin 19 at www.jamehardie.com
- A water-resistive barrier is required in accordance with Part 9.27.3.2 of the NBC. The water-resistive barrier must be appropriately installed with penetration and junction flashings in accordance with Part 9.27.3 of the NBC. James Hardie will assume no responsibility for water infiltration.
- Adjacent finished grade must slope away from the building in accordance with local building codes.
- Do not install James Hardie products, such that they may remain in contact with standing water.
- HardiePanel vertical siding may be installed on vertical wall applications only.
- DO NOT use HardiePanel vertical siding in Fascia or Trim applications.
- For larger projects, including commercial and multi-family projects, where the span of the wall is significant in length, the designer and/or architect should take into consideration the coefficient of thermal expansion and moisture movement of the product in their design. These values can be found in the Technical Bulletin #8 "Expansion Characteristics" at www.JamesHardie.com.
- James Hardie Building Products may be installed on buildings with a maximum mean roof height of 25.9 m (85 feet). For information on installations above 60 feet, please contact JH technical support.
- Minimum standard panel design size is 12" x 16". Note: Panels may be notched and cut to size to fit between windows, doors, corners, etc.

INSTALLATION:

Fastener

Position fasteners 3/8 in from panel edges and no closer than 2 in away from corners. Do not nail into corners.

- HardiePanel vertical siding must be joined on stud.
- Double stud may be required to maintain minimum edge nailing distances.
- When screws are used to attach panels to steel studs/furring, the screws shall have wing tips. If screws do not have wing tips, then pre-drilling is required. (Not applicable when using pins) Follow chart below for pre-drilling:

SCREW	PRE-DRILL	HEAD DIAMETER
No. 8	7/32 in	Min 0.323 in
No. 10	1/4 in	Min 0.323 in

Joint Treatment

- Vertical Joints - Install panels in moderate contact (fig. 1), alternatively joints may also be covered with battens, PVC or metal jointers or caulked (Not applicable to ColorPlus® Finish) (fig. 2).
- Horizontal Joints - Provide Z-flashing at all horizontal joints (fig. 3).

Figure 1

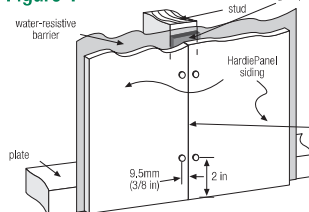

Figure 2

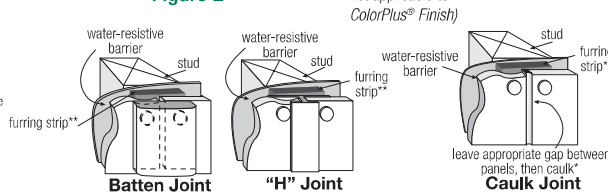

Figure 3

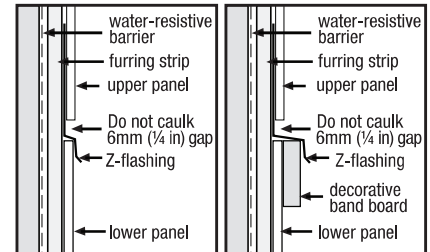
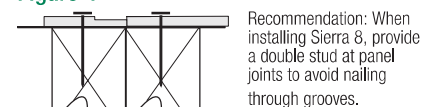

Figure 4



*Apply caulk in accordance with caulk manufacturer's written application instructions.
 **James Hardie recommends installing a rainscreen (an air gap) between the HardiePanel siding and the water-resistive barrier as a best practice.
 James Hardie recommends that you consult your design professional if you have questions regarding the use of rainscreen on your single family project.
 †For additional information on HardieWrap™ Weather Barrier, consult James Hardie at 1-866-4Hardie or www.hardiewrap.com



SMOOTH | CEDARMILL® | STUCCO | SIERRA 8

Visit jameshardiepros.com for the most recent version.

HS1235 P1/4 09/19



CLEARANCE AND FLASHING REQUIREMENTS

Install siding and trim products in compliance of Part 9.27.2.4 of the NBC which requires a minimum 200mm (8 in) for clearance between the bottom edge of the siding and the adjacent finished grade.

Figure 3
Roof to Wall

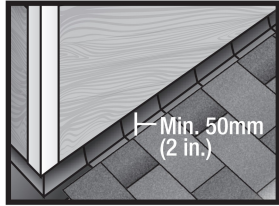

Figure 4
Horizontal Flashing

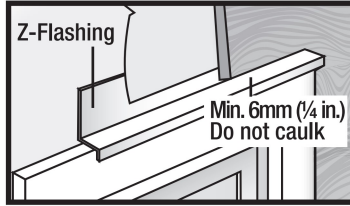

Figure 5
Kickout Flashing

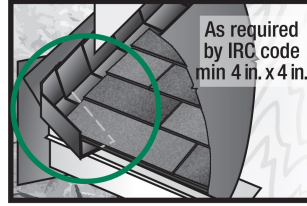
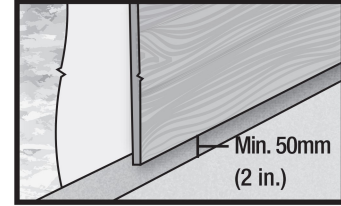

Figure 6
Slabs, Path, Steps to Siding



At the juncture of the roof and vertical surfaces, flashing and counterflashing shall be installed per the roofing manufacturer's instructions. Part 9.27.2.4 requires a minimum 50mm (2 in) clearance between the roofing and the bottom edge of the siding and trim. (fig. 3)

Figure 7
Deck to Wall

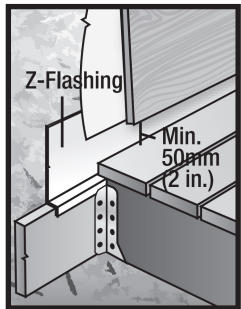

Figure 8
Ground to Siding

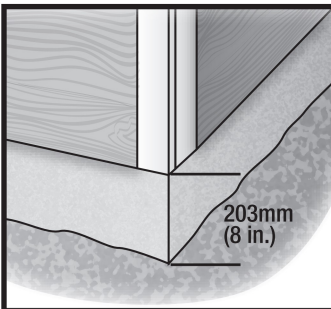

Figure 9
Gutter to Siding

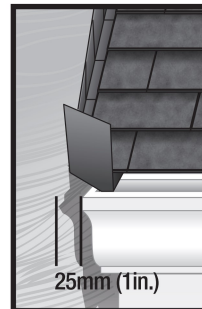

Figure 10
Sheltered Areas

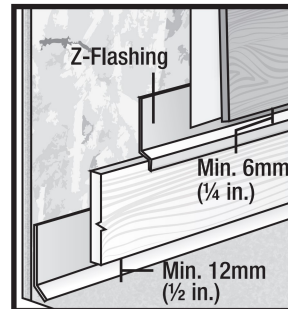

Figure 11
Mortar/Masonry

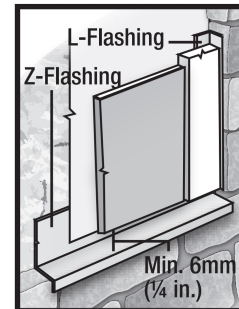

Figure 12
Drip Edge

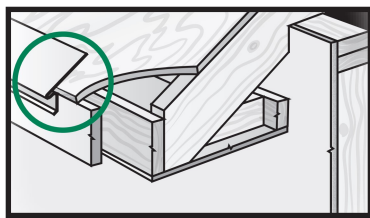

Figure 13
Block Penetration

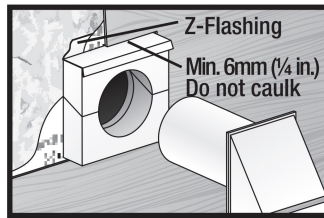
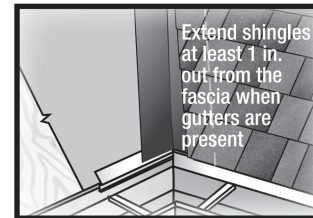
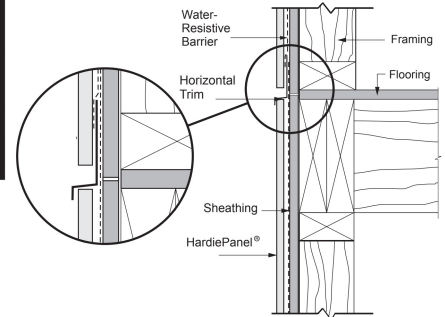

Figure 14
Valley/Shingle Extension



Do not bridge floors with HardiePanel® siding. Horizontal joints should always be created between floors, see below).



GENERAL FASTENING REQUIREMENTS

Fasteners must be corrosion resistant, galvanized, or stainless steel. Electro-galvanized are acceptable but may exhibit premature corrosion. James Hardie recommends the use of quality, hot-dipped galvanized nails. James Hardie is not responsible for the corrosion resistance of fasteners. Stainless steel fasteners are recommended when installing James Hardie® products near the ocean, large bodies of water, or in very humid climates.

Manufacturers of ACQ and CA preservative-treated wood recommend spacer materials or other physical barriers to prevent direct contact of ACQ or CA preservative-treated wood and aluminum products. Fasteners used to attach HardieTrim Tabs to preservative-treated wood shall be of hot dipped zinc-coated galvanized steel or stainless steel and in accordance to 2009 IRC R317.3 or 2009 IBC 2304.9.5

- Consult applicable product evaluation or listing for correct fasteners type and placement to achieve specified design wind loads.
- NOTE: Published wind loads may not be applicable to all areas where Local Building Codes have specific jurisdiction. Consult James Hardie Technical Services if you are unsure of applicable compliance documentation.
- Drive fasteners perpendicular to siding and framing.
- Fastener heads should fit snug against siding (no air space).
- NOTE: Whenever a structural member is present, HardiePanel® should be fastened with even spacing to the structural member. The tables allowing direct to OSB or plywood should only be used when traditional framing is not available.

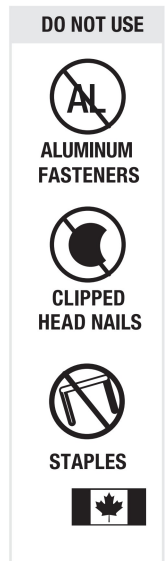
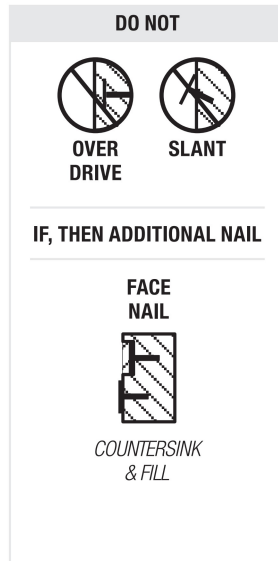
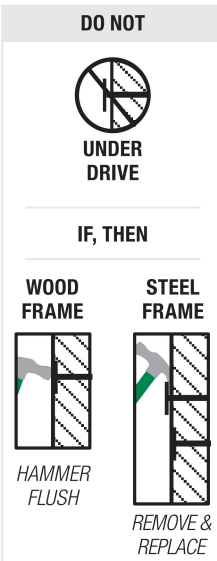
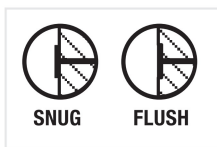



COMPLIANCE:

HardiePanel vertical siding complies with ASTM Specification C1186 (Grade II, Type A) and ISO Standard 8336 (Category A, Class 2, Level I). When tested in accordance with CAN/ULC-S102, the product is recognized to have the following properties: Flame Spread Rating: 0, Smoke Developed Classification: 0. When tested in accordance with CAN/ULC-S114, the product is recognized as noncombustible.

RECOGNITION:

HardiePanel vertical siding is recognized as an exterior wall cladding in CCMC Evaluation Report 12678-R. This document should also be consulted for additional information concerning the suitability of this product for specific applications. For technical assistance, call 1-800-9-HARDIE.

FIRE-RESISTIVE CONSTRUCTION:

HardiePanel vertical siding is recognized as a component in 1-hour & 2-hour fire-related wall construction when tested in accordance with CAN/ULC-S101. Details of the listed assemblies may be found at: <https://bpdirectory.intertek.com>

ALLOWABLE LOADS FOR STRUCTURAL EXTERIOR HARDIEPANEL® VERTICAL SIDING

FRAME TYPES	STUD SPACING	VERTICAL FASTENER SPACING	FASTENERS	RATING (kPa)	
				Non-Post-Disaster Building (Height < 12 m)	Non-Post-Disaster Building (Height < 20 m)
2x4 SPF wood	610 mm (24 in)	305 mm (12 in)	6d common nail (2.87mm x 6.75 mm x 50.8 mm)	Q50<0.55	Q50<0.45
2x4 SPF wood	610 mm (24 in)	203 mm (8 in)	6d siding nail (2.34 mm x 5.64 mm x 50.8 mm)	Q50<0.55	Q50<0.45
2x4 SPF wood	610 mm (24 in)	152 mm (6 in)	6d common nail (2.87mm x 6.75 mm x 50.8 mm)	Q50<0.75	Q50<0.65
2x4 SPF wood	610 mm (24 in)	152 mm (6 in)	4d ring shank siding nail (2.41 mm x 5.56 mm x 38 mm)	Q50<0.55	Q50<0.45
20-ga. steel	610 mm (24 in)	305 mm (12 in)	#8 bugle head screw (8.2 mm x 31.8 mm)	Q50<0.45	N/A
20-ga. steel	610 mm (24 in)	203 mm (8 in)	1.5 in ET&F fastener (2.54 mm x 6.35 mm x 38 mm)	Q50<0.55	Q50<0.45
20-ga. steel	406 mm (16 in)	152 mm (6 in)	1.5 in ET&F fastener (2.54 mm x 6.35 mm x 38 mm)	Q50<0.75	Q50<0.65

METRIC TO IMPERIAL CONVERSION TABLE

The following table provides a conversion of the nominal metric measurements presented in these installation instructions to nominal Imperial fraction measurement values

mm	inches	mm	inches	mm	inches	mm	inches
2.3	3/32	6.7	17/64	25	1	150	6
2.5	3/32	7.5	5/16	38	1-1/2	203	8
2.8	7/64	8.2	21/64	50	2	305	12
5.7	7/32	9	23/64	92	3-5/8	406	16
6.2	1/4	12	15/32	102	4	610	24





CUT EDGE TREATMENT

Caulk, paint or prime all field cut edges. James Hardie touch-up kits are required to touch-up ColorPlus products.

CAULKING

For best results use an Elastomeric Joint Sealant complying with ASTM C920 Grade NS, Class 25 or higher or a Latex Joint Sealant complying with ASTM C834. Caulking/Sealant must be applied in accordance with the caulking/sealant manufacturer's written instructions. **Note: some caulking manufacturers do not allow "tooling".**

PAINTING

DO NOT use stain, oil/alkyd base paint, or powder coating on James Hardie® products. James Hardie products must be painted within 180 days for primed product and 90 days for unprimed. 100% acrylic topcoats are recommended. Do not paint when wet. For application rates refer to paint manufacturers specifications. Back-rolling is recommended if the siding is sprayed.

PAINTING JAMES HARDIE® SIDING AND TRIM PRODUCTS WITH COLORPLUS® TECHNOLOGY

When repainting ColorPlus products, James Hardie recommends the following regarding surface preparation and topcoat application:

- Ensure the surface is clean, dry, and free of any dust, dirt, or mildew
- Repriming is normally not necessary
- 100% acrylic topcoats are recommended
- DO NOT use stain, oil/alkyd base paint, or powder coating on James Hardie® Products.
- Apply finish coat in accordance with paint manufacturers written instructions regarding coverage, application methods, and application temperature
- DO NOT caulk nail heads when using ColorPlus products, refer to the ColorPlus touch-up section

COLORPLUS® TECHNOLOGY CAULKING, TOUCH-UP & LAMINATE

- Care should be taken when handling and cutting James Hardie ColorPlus® products. During installation use a wet soft cloth or soft brush to gently wipe off any residue or construction dust left on the product, then rinse with a garden hose.
- Touch up nicks, scrapes and nail heads using the ColorPlus® Technology touch-up applicator. Touch-up should be used sparingly. If large areas require touch-up, replace the damaged area with a new piece of siding with ColorPlus® Technology.
- Laminate sheet must be removed immediately after installation of each course.
- Terminate non-factory cut edges into trim where possible, and caulk. Color matched caulks are available from your ColorPlus® product dealer.
- Treat all other non-factory cut edges using the ColorPlus Technology edge coat, available from your ColorPlus product dealer.

Note: James Hardie does not warrant the usage of third party touch-up or paints used as touch-up on James Hardie ColorPlus products.

Problems with appearance or performance arising from use of third party touch-up paints or paints used as touch-up that are not James Hardie touch-up will not be covered under the James Hardie ColorPlus Limited Finish Warranty.

SILICA WARNING

DANGER: May cause cancer if dust from product is inhaled. Causes damage to lungs and respiratory system through prolonged or repeated inhalation of dust from product. Refer to the current product Safety Data Sheet before use. The hazard associated with fiber cement arises from crystalline silica present in the dust generated by activities such as cutting, machining, drilling, routing, sawing, crushing, or otherwise abrading fiber cement, and when cleaning up, disposing of or moving the dust. When doing any of these activities in a manner that generates dust you must (1) comply with the OSHA standard for silica dust and/or other applicable law, (2) follow James Hardie cutting instructions to reduce or limit the release of dust; (3) warn others in the area to avoid breathing the dust; (4) when using mechanical saw or high speed cutting tools, work outdoors and use dust collection equipment; and (5) if no other dust controls are available, wear a dust mask or respirator that meets NIOSH requirements (e.g. N-95 dust mask). During clean-up, use a well maintained vacuum and filter appropriate for capturing fine (respirable) dust or use wet clean-up methods - never dry sweep.

WARNING: This product can expose you to chemicals including respirable crystalline silica, which is known to the State of California to cause cancer. For more information go to P65Warnings.ca.gov.

