

## HardieSoffit® Panel Product Description

### HARDIESOFFIT® PANELS

HardieSoffit® panels are 8 ft. and 12 ft. long, ¼ in. thick factory-primed fiber-cement panels designed to be used on the underside of eaves as soffit material. HardieSoffit panels are available as vented or non-vented boards. Vented HardieSoffit panels provide 5 sq. in. of net free ventilation per lineal foot of soffit.

James Hardie offers HardieSoffit panels in a range of time-saving pre-cut widths common to rake and eave applications. HardieSoffit panels come in either a smooth finish or Select Cedarmill® textured finish. Check with your local dealer for product availability. HardieSoffit panels can be combined with HardieTrim® Fascia boards used for fascia rakes and frieze applications to complete the eaves detailing.

HardieSoffit panels are also available with ColorPlus® Technology. The ColorPlus® coating is a factory-applied, oven-baked finish available on a variety of James Hardie® siding and trim products. See your local dealer for details and availability of products, colors and accessories.

### HARDIESOFFIT® BEADED PORCH PANEL

HardieSoffit Beaded Porch Panel is a decorative fiber cement panel to be used as ceiling on the underside of porches or eaves as exterior panel materials. HardieSoffit beaded porch panel is ¼ in. thick, 4 ft. wide, 8 ft. in length, and has 2 in. o.c. beads, and comes with PrimePlus® factory primer and sealer. Must be finished with 100% acrylic paint. See your local dealer for details and availability of products, colors and accessories.



HardieSoffit Vented Smooth



HardieSoffit Vented Cedarmill®

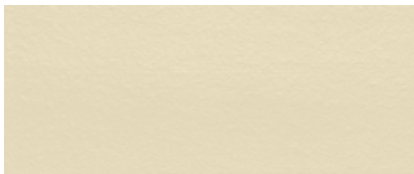

HardieSoffit Non-Vented Smooth



HardieSoffit Non-Vented Cedarmill®



HardieSoffit Beaded Porch Panel



HardieSoffit Beaded Porch Panel

HardieSoffit Non-Vented Smooth

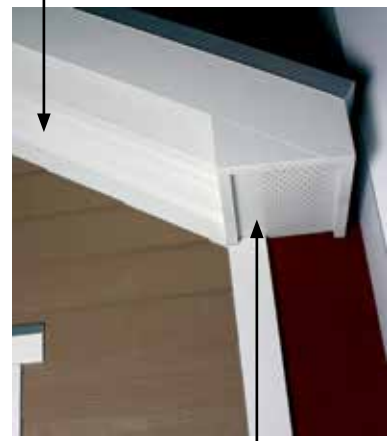

HardieSoffit Vented Smooth

# Installation of HardieSoffit® Panels

## INSTALLATION OF HARDIESOFFIT® PANELS

HardieSoffit® panels must be attached to solid framing such as 2x4 supports spaced no more than 24 in o.c. For eaves install HardieSoffit panels with the long edge of the panel perpendicular to the ends of the rafters or joists. Eaves framing must include a subfascia, blocking, and/or ledger board to provide solid nailing along the long dimension of the soffit. All panel edges must be supported.

For rake overhangs 2x “look outs” spaced a maximum of 24 in o.c. should support a rake subfascia to provide adequate nailing for the rake soffit. Blocking between the lookouts provides support for the rake soffit along the building.

### 9.1 Soffit Framing

All edges of the soffit panels must be supported

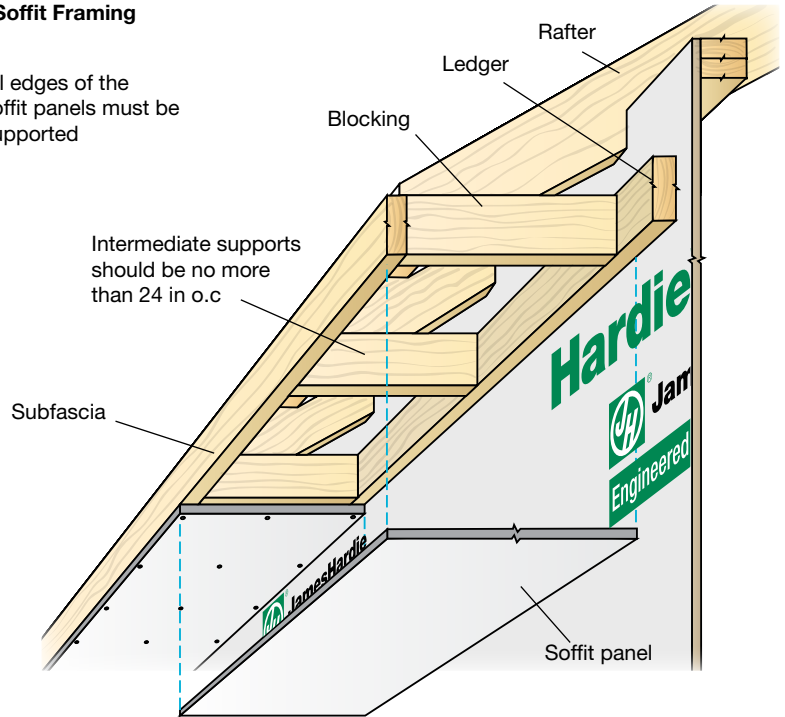

**TIP:** To aid in soffit panel installation, make a “deadman” or “third hand” post to help hold and position the soffit panel. Factory built tools such as those made for drywall installation are available, or they can be fabricated from lumber on the job-site.

## JOINT TREATMENT FOR HARDIESOFFIT PANELS

There are several ways to join the lengths of HardieSoffit panels. Panel ends may be lightly butted in moderate contact, the ends may be gapped 1/8 in. and caulked, joints can be covered with batten strips, or panels may be joined with PVC or metal H molding type connectors.

### 9.2

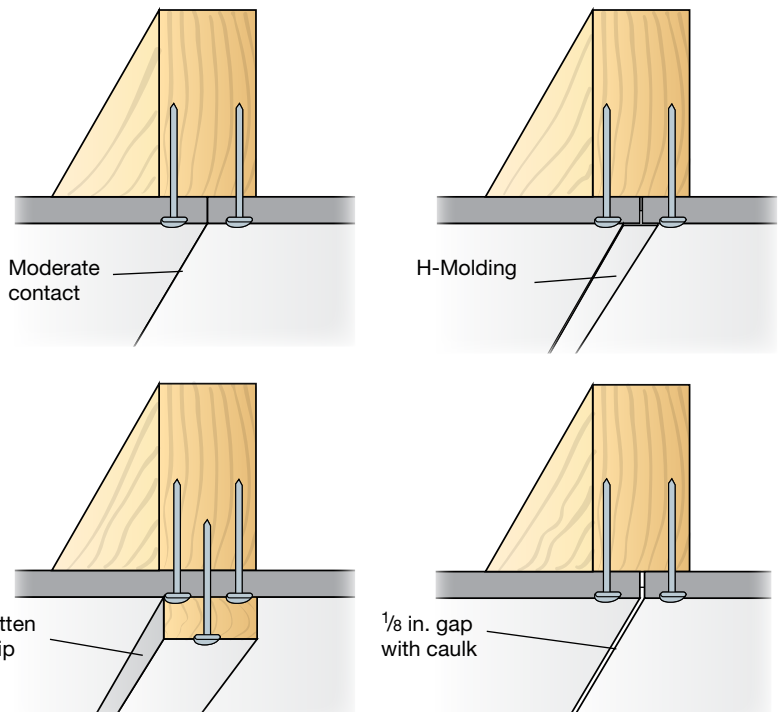

## FRAMING PREP FOR SOFFIT PANELS

9.3

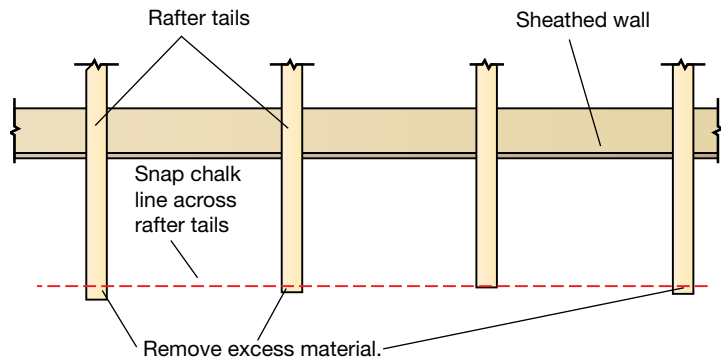

9.4

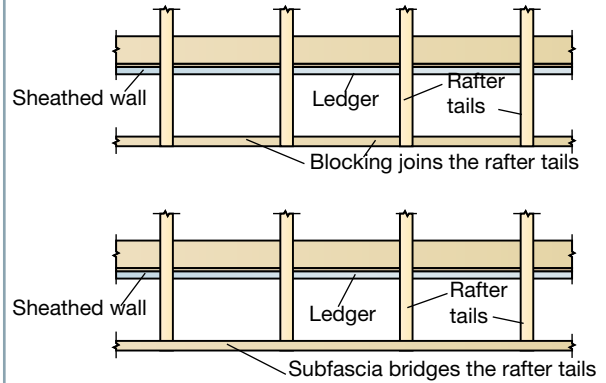

When installing the soffit:

1. Straighten the rafter tails by pulling and snapping a chalk line across the ends of the tails and then trimming them as necessary.
2. Install a solid wood sub-fascia on the ends of the rafter tails or install blocking between the rafter tails as needed.
3. If the soffit is to be installed level across its width, add nailers at every rafter or truss to provide support.
4. If the eaves are longer than 12 ft, measure and trim the first HardieSoffit® panel making sure that the end falls in the middle of a nailer.
5. Using the subfascia as a guide along the edge, carefully position the panel and secure with 4d common galvanized nails spaced no greater than 8 in. o.c. at all panel edges and on all intermediate framing members.
6. Continue with additional pieces until the run is complete.

9.5

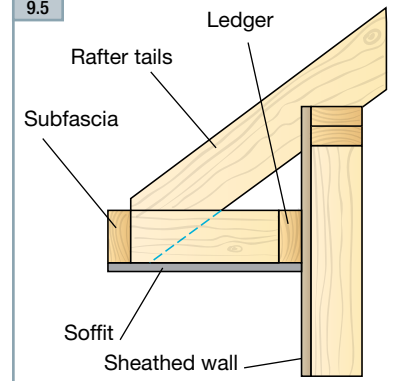

## CUTTING 45° HIP ROOF SOFFITS

Hip roof soffits continue level around the corners of a house. The soffit panels should join at the corner with 45° angle cuts. To create these corners:

1. First measure from the corner to the perpendicular framing member closest to, but not over 12 ft.
2. Using that measurement and pulling from the factory cut end of the soffit panel, mark the outside edge of the soffit panel for the long point of the 45° cut.
3. After cutting the 45° angle, position the panel on the soffit framing and check the fit on both ends before fastening.
4. Begin nailing at the 45° cut end and work toward the factory end.

9.6 Hip roof soffits

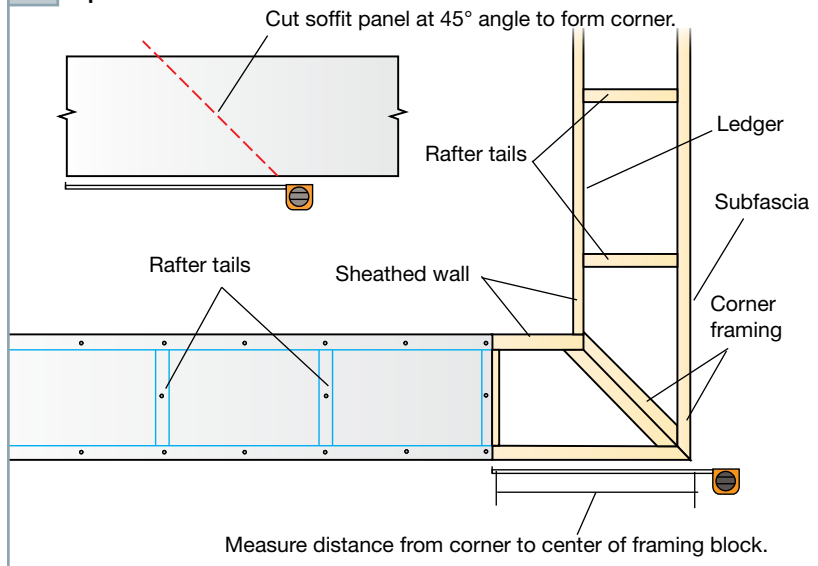

### WARNING

When using vented soffit, place the vented section of the panel toward the outside of the eave for optimum airflow.

General  
Product  
Information

Working  
Safety

Tools for  
Cutting and  
Fastening

General  
Installation  
Requirements

General  
Fastener  
Requirements

Finishing and  
Maintenance

HardieWrap®  
Weather Barrier

HardieTrim®  
Boards/Battens

HardieSoffit®  
Panels

HardiePlank®  
Lap Siding

HardieShingle®  
Siding

HardiePanel®  
Vertical Siding

Appendix/  
Glossary

ESR-1844 &  
2290 Report

# Installation of HardieSoffit® Panels (cont.)

## INSTALLING FRIEZE BOARDS

### FRIEZE MADE FROM HARDIETRIM®

#### 5/4, 4/4 BOARDS

When using lap and shingle sidings, install HardieTrim 5/4, 4/4 boards as a frieze board before putting in the siding. Then run courses of siding up to the frieze board and caulk the junction of the frieze board and siding. In a building sided with HardiePanel siding, the frieze board is commonly over the panel siding. If joints in the HardieTrim boards frieze are necessary for longer runs, join boards with a bevel cut. Nail the frieze board every 16 in using finish or siding nails.

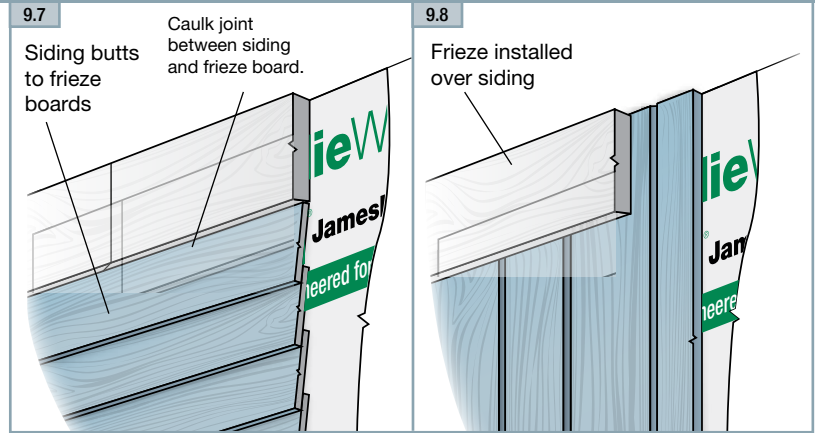

## TREATMENT OPTIONS FOR THE SIDING/SOFFIT JUNCTURE

In addition to the frieze board treatments described above, there are several other options for finishing the juncture where the siding meets the soffit.

### CAULK THE SIDING/SOFFIT JOINT

A fast and economical method of finishing the siding/soffit juncture is simply to run a bead of quality caulk along the top edge of the siding where it meets the soffit. A straight rip cut along the top edge of the siding ensures an aesthetically pleasing fit where it meets the soffit.

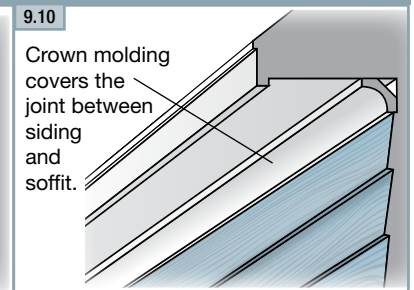
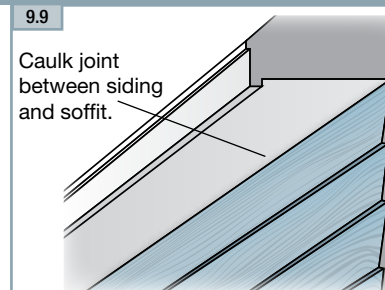

### INSTALL CROWN MOLDING

Crown molding is another way of finishing and sealing the soffit/siding juncture. Install and finish the crown molding according to the manufacturer's specifications.

### OVER THE TOP OF THE SIDING WITH 'J' CHANNEL

Once the soffit is in place, install a vinyl "J" channel upside down with the base of the "J" against the soffit. Then rip the final course of siding so that it fits inside the channel.

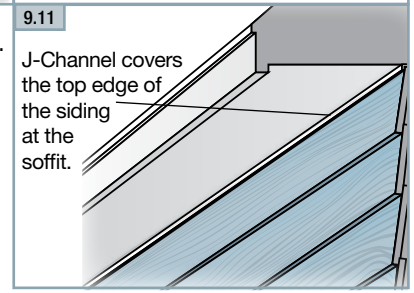

## INSECT SCREEN

In areas where additional insect protection is desired, a screen may be applied to the back side of the panel prior to soffit installation. After the screen type and size is selected, cut the screen to fit so that it covers the vent holes and overlaps the non-vented area of the soffit by 1 in. to 2 in. Secure the screen to the backside of the soffit panel using a bead of construction adhesive.

**TIP:** Stainless steel fasteners are recommended when installing James Hardie® products.

## HARDIESOFFIT® PANEL FASTENER SPECIFICATIONS

The Fastener Specifications table shows fastener options for a variety of different nailing substrates. Please refer to the applicable ESR report online (see back page) to determine which fastener meets your wind load design criteria.

Fastening Substrate	Approved Fastener	Fastening Types
wood studs	16 in o.c.	① ⑥
	22.5 in o.c.	⑥
	24 in o.c.	①
steel studs	16 in o.c.	⑦

①		4d common
	.113 in x .267 in x 1.5 in	
⑥		ring shank siding nail
	.083 in x .187 in x 1.5 in	
⑦		screw
	Ribbed Bugle-Head No. 8	
	.323 in x 1 in	

**WARNING**

Please note that the addition of an insect screen reduces the total amount of vent area of the soffit depending on the size screen used.

# Installation of HardieSoffit® Beaded Porch Panels

General Product Information

Working Safely

Tools for Cutting and Fastening

General Installation Requirements

General Fastener Requirements

Finishing and Maintenance

HardieWrap® Weather Barrier

HardieTrim® Boards/Battens

HardieSoffit® Panels

HardiePlank® Lap Siding

HardieShingle® Siding

HardiePanel® Vertical Siding

Appendix/ Glossary

ESR-1844 & 2290 Report

## BEADED PORCH PANEL FRAMING

HardieSoffit Beaded Porch Panel must be attached to either steel or wood normal 2x4 framing members spaced a maximum 24 in on center. All edges must be supported by framing.

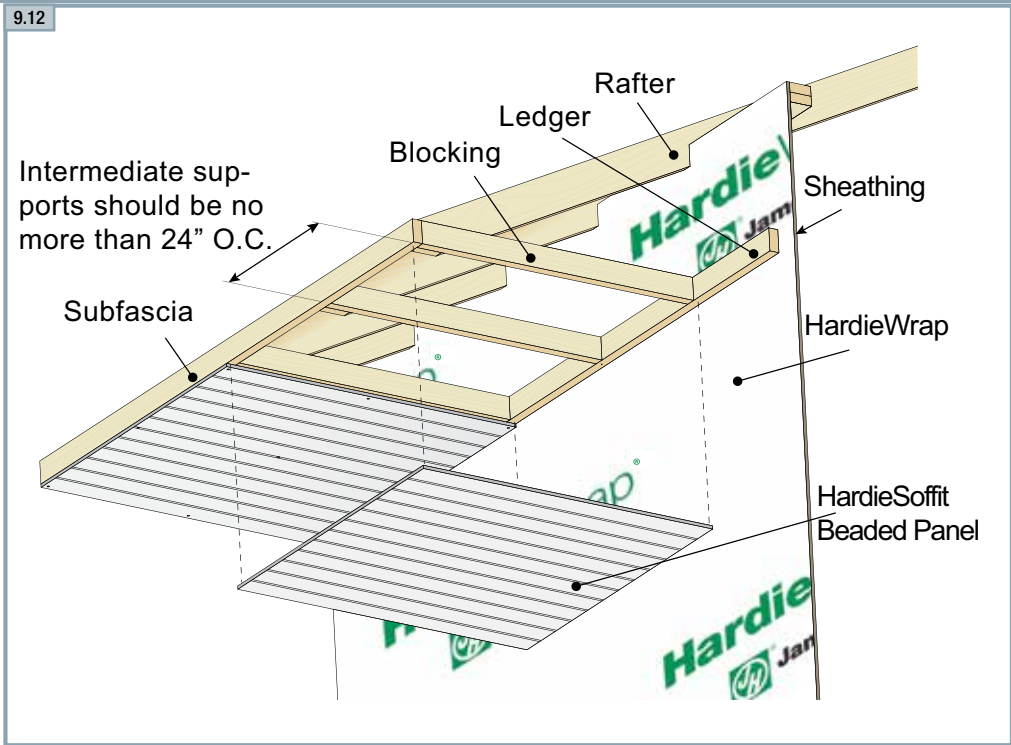

**TIP:** Stainless steel fasteners are recommended when installing James Hardie products near the ocean, large bodies of water, or in very humid climates.

## JOINT TREATMENT FOR BEADED PORCH PANEL

There are several ways to treat the joints of HardieSoffit beaded porch panels. The panel edges can be butted in moderate contact, leave a gap and caulk; or joints can be covered with Hardietrim batten strips.

**TIP:** Do not use finish nails for HardieSoffit beaded porch panel installation.

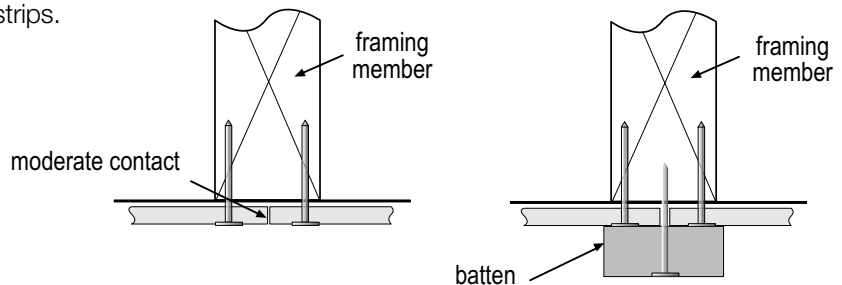



# Installation of HardieSoffit® Beaded Porch Panels (cont.)

## HANDLING DURING INSTALLATION

Special precautions may be needed for carrying the panel during installation because of its larger size. James Hardie recommends the use of a T shape frame to support the panel during installation.



## SIDING/BEADED PORCH PANEL JOINT

A fast and economical method of finishing the siding/porch panel juncture is simply to run a bead of quality caulk along the top edge of the siding where it meets the soffit. A straight rip cut along the top edge of the siding ensures an aesthetically pleasing fit where it meets the beaded porch panel.

9.13

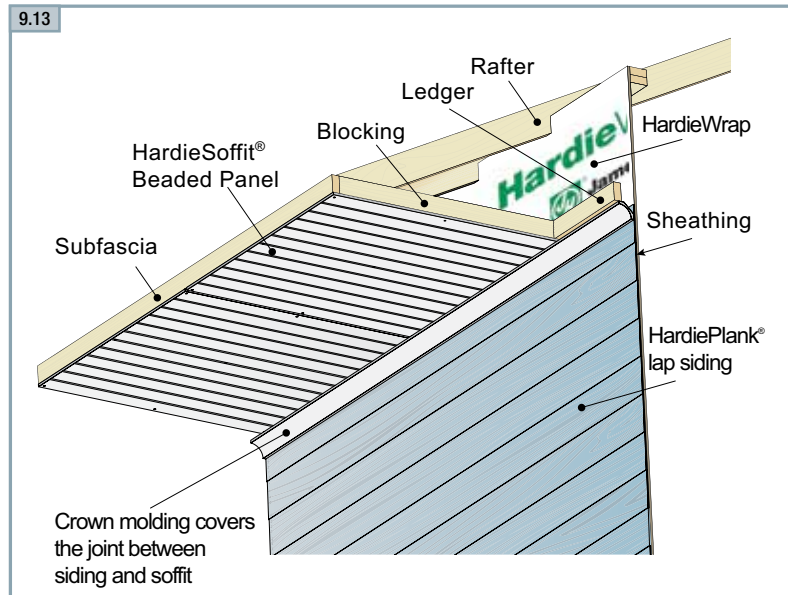

9.14

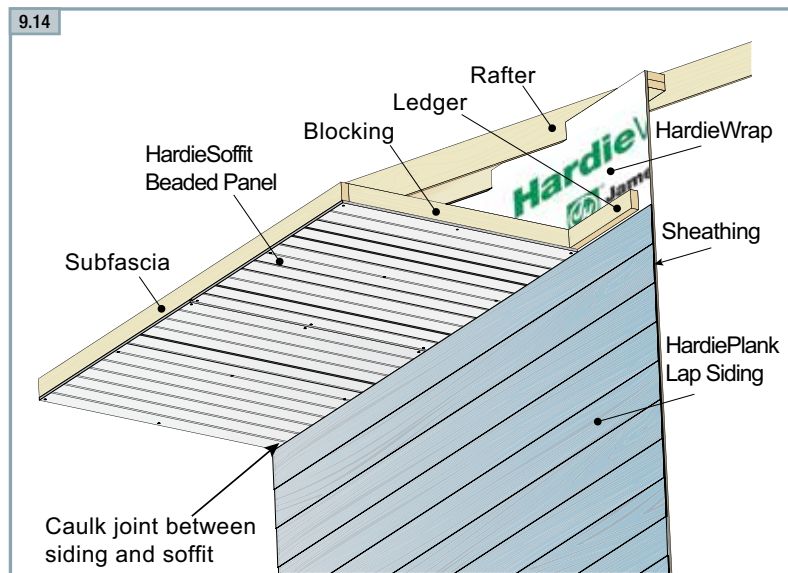



**IMPORTANT: FAILURE TO FOLLOW JAMES HARDIE WRITTEN INSTALLATION INSTRUCTIONS AND COMPLY WITH APPLICABLE BUILDING CODES MAY VIOLATE LOCAL LAWS, AFFECT BUILDING ENVELOPE PERFORMANCE AND MAY AFFECT WARRANTY COVERAGE. FAILURE TO COMPLY WITH ALL HEALTH AND SAFETY REGULATIONS WHEN CUTTING AND INSTALLING THIS PRODUCT MAY RESULT IN PERSONAL INJURY. BEFORE INSTALLATION, CONFIRM YOU ARE USING THE CORRECT HARDIEZONE® PRODUCT INSTRUCTIONS BY VISITING HARDIEZONE.COM OR CALL 1-866-942-7343 (866-9-HARDIE)**

**STORAGE & HANDLING:**

Store flat and keep dry and covered prior to installation. Installing siding wet or saturated may result in shrinkage at butt joints. Carry planks on edge. Protect edges and corners from breakage. James Hardie is not responsible for damage caused by improper storage and handling of the product.



**CUTTING INSTRUCTIONS**

**OUTDOORS**

- Position cutting station so that airflow blows dust away from the user and others near the cutting area.
- Cut using one of the following methods:
  - Best: Circular saw equipped with a HardieBlade® saw blade and attached vacuum dust collection system. Shears (manual, pneumatic or electric) may also be used, not recommended for products thicker than 7/16 in.
  - Better: Circular saw equipped with a dust collection feature (e.g. Roan® saw) and a HardieBlade saw blade.
  - Good: Circular saw equipped with a HardieBlade saw blade.

**INDOORS**

- DO NOT grind or cut with a power saw indoors. Cut using shears (manual, pneumatic or electric) or the score and snap method, not recommended for products thicker than 7/16 in.
- DO NOT dry sweep dust; use wet dust suppression or vacuum to collect dust.
  - For maximum dust reduction, James Hardie recommends using the "Best" cutting practices. Always follow the equipment manufacturer's instructions for proper operation.
  - For best performance when cutting with a circular saw, James Hardie recommends using HardieBlade® saw blades.
  - Go to jameshardiepros.com for additional cutting and dust control recommendations.

**IMPORTANT:** The Occupational Safety and Health Administration (OSHA) regulates workplace exposure to silica dust. For construction sites, OSHA has deemed that cutting fiber cement with a circular saw having a blade diameter less than 8 inches and connected to a commercially available dust collection system per manufacturer's instructions results in exposures below the OSHA Permissible Exposure Limit (PEL) for respirable crystalline silica, without the need for additional respiratory protection.

If you are unsure about how to comply with OSHA silica dust regulations, consult a qualified industrial hygienist or safety professional, or contact your James Hardie technical sales representative for assistance. James Hardie makes no representation or warranty that adopting a particular cutting practice will assure your compliance with OSHA rules or other applicable laws and safety requirements.

**GENERAL REQUIREMENTS:**

- HardieSoffit® panels may be installed as a soffit or ceiling over either wood or steel 20 gauge (33 mils) minimum to 16 gauge (54 mils) framing complying with the local building code. See general fastening requirements. Install soffits to nominal 2 x 4 framing members spaced a maximum of 24 inches on center (fig.1), with the long dimension perpendicular to the rafter or joist framing.
- All edges must be supported by framing. (figs. 3 & 4)
- Install water barriers and air barriers as required by local building codes. James Hardie will assume no responsibility for moisture infiltration.
- Ensure gutters have end caps. Maintain a minimum 1 in gap between end caps and siding & trim (fig.5).
- Install kickout flashing at roof-wall junctions. (fig 6.)
- James Hardie Building Products provides installation /wind load information for buildings with a maximum mean roof height of 85 feet. For information on installations above 60 feet, please contact JH technical support.

**INSTALLATION:**

- HardieSoffit panels must be fastened to a solid, nailable substrate such as a wood 2x subfascia.
- Additional framing may be needed to ensure proper fastening.
- Soffits can be installed as shown in figure 1. Position the vent holes toward the outside of the eave for optimal airflow.
- 12 in to 24 in wide Vented HardieSoffit panels, provide 5.0 square inches of net free ventilation per lineal foot.
- Alternatively vents can be installed into non-vented soffit.
- If necessary, an insect screen can be installed using construction adhesive. Note: net free ventilation will be reduced.

**Fastener Positioning**

- Position fasteners 3/8 in from panel edges and no closer than 2 in away from corners when using soffit greater than 12 in wide (fig. 4) and no closer than 1 in away from corners when using soffit that is less than or equal to 12 in wide (fig. 3).

**Jointing Methods**

- Install panels in moderate contact at ends, provide PVC or metal jointers, battens or leave appropriate gap and caulk (fig 2).

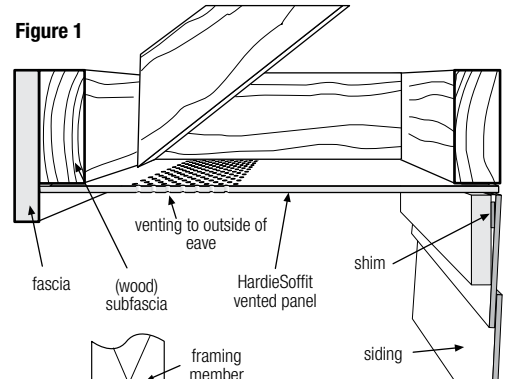
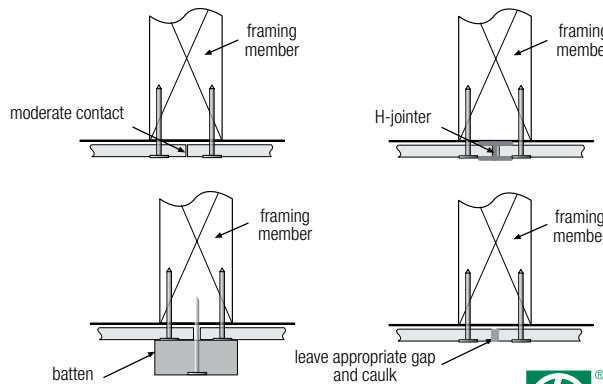

Figure 2



<sup>1</sup>For additional information on HardieWrap® Weather Barrier, consult James Hardie at 1-866-4Hardie or www.hardiewrap.com



**Figure 3**  
less than or equal to 12 in Wide Soffit

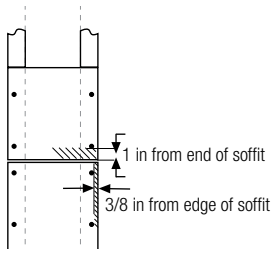

**Figure 4**  
Greater than 12 in Wide Soffit

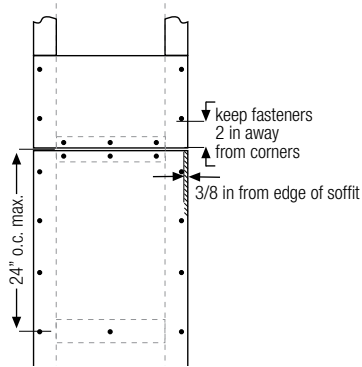

**Figure 5**  
Maintain a minimum 1 in gap between gutter end caps and siding & trim.

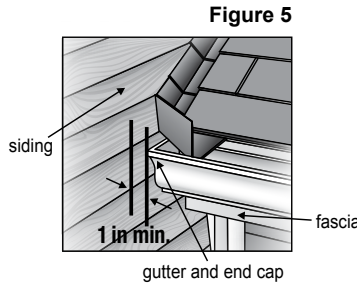

**Figure 6**

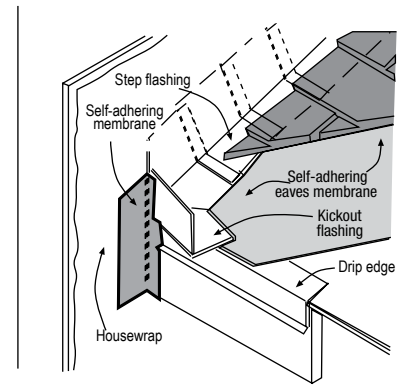

### FASTENER REQUIREMENTS

- For wood frame construction a minimum 4d common nails spaced 8 in o.c. at panel edges and intermediate framing members spaced up to 24 in on center are suitable in most locations\*.
- For conventional 20ga - 16ga steel frame construction a minimum No. 8-18 x 0.323 in HD x 1 in long ribbed bugle screws spaced 6 in o.c. at panel edges and intermediate framing members spaced up to 24 in on center are suitable in most locations\*.

\*Minimum Basic Wind Speed differs by locality. Where specified levels of wind resistance are required, refer to applicable Building Code Compliance Reports.

Manufacturers of ACQ and CA preservative-treated wood recommend spacer materials or other physical barriers to prevent direct contact of ACQ or CA preservative-treated wood and aluminum products. Fasteners used to attach HardieTrim Tabs to preservative-treated wood shall be of hot dipped zinc-coated galvanized steel or stainless steel and in accordance to 2009 IRC R317.3 or 2009 IBC 2304.9.5."

### GENERAL FASTENING REQUIREMENTS

Fasteners must be corrosion resistant, galvanized, or stainless steel. Electro-galvanized are acceptable but may exhibit premature corrosion. James Hardie recommends the use of quality, hot-dipped galvanized nails. James Hardie is not responsible for the corrosion resistance of fasteners. Stainless steel fasteners are recommended when installing James Hardie® products near the ocean, large bodies of water, or in very humid climates.

Manufacturers of ACQ and CA preservative-treated wood recommend spacer materials or other physical barriers to prevent direct contact of ACQ or CA preservative-treated wood and aluminum products. Fasteners used to attach HardieTrim Tabs to preservative-treated wood shall be of hot dipped zinc-coated galvanized steel or stainless steel and in accordance to 2009 IRC R317.3 or 2009 IBC 2304.9.5

- Consult applicable product evaluation or listing for correct fasteners type and placement to achieve specified design wind loads.
- NOTE: Published wind loads may not be applicable to all areas where Local Building Codes have specific jurisdiction. Consult James Hardie Technical Services if you are unsure of applicable compliance documentation.
- Drive fasteners perpendicular to siding and framing.
- Fastener heads should fit snug against siding (no air space).
- NOTE: Whenever a structural member is present, HardiePlank should be fastened with even spacing to the structural member. The tables allowing direct to OSB or plywood should only be used when traditional framing is not available.

### KICKOUT FLASHING

Because of the volume of water that can pour down a sloped roof, one of the most critical flashing details occurs where a roof intersects a sidewall. The roof must be flashed with step flashing. Where the roof terminates, install a kickout to deflect water away from the siding. It is best to install a self-adhering membrane on the wall before the subfascia and trim boards are nailed in place, and then come back to install the kickout.

**Figure 6, Kickout Flashing** To prevent water from dumping behind the siding and the end of the roof intersection, install a "kickout" as required by IRC code R905.2.8.3 : "...flashing shall be a min. of 4" high and 4" wide." James Hardie recommends the kickout be angled between 100° - 110° to maximize water deflection

### PNEUMATIC FASTENING

James Hardie products can be hand nailed or fastened with a pneumatic tool. Pneumatic fastening is highly recommended. Set air pressure so that the fastener is driven snug with the surface of the siding. A flush mount attachment on the pneumatic tool is recommended. This will help control the depth the nail is driven. If setting the nail depth proves difficult, choose a setting that under drives the nail. (Drive under driven nails snug with a smooth faced hammer - Does not apply for installation to steel framing).

<p><b>SNUG</b>      <b>FLUSH</b></p>		<p><b>DO NOT</b></p> <p><b>UNDER DRIVE</b></p>		<p><b>DO NOT</b></p> <p><b>OVER DRIVE</b>      <b>SLANT</b></p>		<p><b>DO NOT USE</b></p> <p><b>ALUMINUM FASTENERS</b></p> <p><b>CLIPPED HEAD NAILS</b></p> <p><b>STAPLES</b></p>	
<p><b>IF, THEN</b></p> <p><b>WOOD FRAME</b></p> <p>HAMMER FLUSH</p>		<p><b>IF, THEN</b></p> <p><b>STEEL FRAME</b></p> <p>REMOVE &amp; REPLACE</p>		<p><b>IF, THEN ADDITIONAL NAIL</b></p> <p><b>FACE NAIL</b></p> <p>COUNTERSINK &amp; FILL</p>			





## CUT EDGE TREATMENT

Caulk, paint or prime all field cut edges. James Hardie touch-up kits are required to touch-up ColorPlus products.

## CAULKING

For best results use an Elastomeric Joint Sealant complying with ASTM C920 Grade NS, Class 25 or higher or a Latex Joint Sealant complying with ASTM C834. Caulking/Sealant must be applied in accordance with the caulking/sealant manufacturer's written instructions.

**Note: some caulking manufacturers do not allow "tooling".**

## PAINTING

DO NOT use stain, oil/alkyd base paint, or powder coating on James Hardie® Products. Factory-primed James Hardie products must be painted within 180 days of installation. 100% acrylic topcoats are recommended. Do not paint when wet. For application rates refer to paint manufacturers specifications. Back-rolling is recommended if the siding is sprayed.

## PAINTING JAMES HARDIE® SIDING AND TRIM PRODUCTS WITH COLORPLUS® TECHNOLOGY

When repainting ColorPlus products, James Hardie recommends the following regarding surface preparation and topcoat application:

- Ensure the surface is clean, dry, and free of any dust, dirt, or mildew
- Repriming is normally not necessary
- 100% acrylic topcoats are recommended
- DO NOT use stain, oil/alkyd base paint, or powder coating on James Hardie® Products.
- Apply finish coat in accordance with paint manufacturers written instructions regarding coverage, application methods, and application temperature
- DO NOT caulk nail heads when using ColorPlus products, refer to the ColorPlus touch-up section

## COLORPLUS® TECHNOLOGY CAULKING, TOUCH-UP & LAMINATE

- Care should be taken when handling and cutting James Hardie® ColorPlus® products. During installation use a wet soft cloth or soft brush to gently wipe off any residue or construction dust left on the product, then rinse with a garden hose.
- Touch up nicks, scrapes and nail heads using the ColorPlus® Technology touch-up applicator. Touch-up should be used sparingly. If large areas require touch-up, replace the damaged area with new HardiePlank® lap siding with ColorPlus® Technology.
- Laminate sheet must be removed immediately after installation of each course.
- Terminate non-factory cut edges into trim where possible, and caulk. Color matched caulks are available from your ColorPlus® product dealer.
- Treat all other non-factory cut edges using the ColorPlus Technology edge coat, available from your ColorPlus product dealer.

**Note:** James Hardie does not warrant the usage of third party touch-up or paints used as touch-up on James Hardie ColorPlus products.

Problems with appearance or performance arising from use of third party touch-up paints or paints used as touch-up that are not James Hardie touch-up will not be covered under the James Hardie ColorPlus Limited Finish Warranty.

SF1204 P3/3 04/18

### SILICA WARNING

**DANGER:** May cause cancer if dust from product is inhaled. Causes damage to lungs and respiratory system through prolonged or repeated inhalation of dust from product. Refer to the current product Safety Data Sheet before use. The hazard associated with fiber cement arises from crystalline silica present in the dust generated by activities such as cutting, machining, drilling, routing, sawing, crushing, or otherwise abrading fiber cement, and when cleaning up, disposing of or moving the dust. When doing any of these activities in a manner that generates dust you must (1) comply with the OSHA standard for silica dust and/or other applicable law, (2) follow James Hardie cutting instructions to reduce or limit the release of dust; (3) warn others in the area to avoid breathing the dust; (4) when using mechanical saw or high speed cutting tools, work outdoors and use dust collection equipment; and (5) if no other dust controls are available, wear a dust mask or respirator that meets NIOSH requirements (e.g. N-95 dust mask). During clean-up, use a well maintained vacuum and filter appropriate for capturing fine (respirable) dust or use wet clean-up methods - never dry sweep.

**WARNING:** This product can expose you to chemicals including respirable crystalline silica, which is known to the State of California to cause cancer. For more information go to [P65Warnings.ca.gov](http://P65Warnings.ca.gov).

**RECOGNITION:** In accordance with ICC-ES Evaluation Report ESR-2290, HardiePlank® lap siding is recognized as a suitable alternate to that specified in: the 2006, 2009, & 2012 International Residential Code for One- and Two-Family Dwellings, and the 2006, 2009, & 2012 International Building Code. HardiePlank lap siding is also recognized for application in the following: City of Los Angeles Research Report No. 24862, State of Florida listing FL#889, Dade County, Florida NOA No. 02-0729.02, U.S. Dept. of HUD Materials Release 1263c, Texas Department of Insurance Product Evaluation EC-23, City of New York MEA 223-93-M, and California DSA PA-019. These documents should also be consulted for additional information concerning the suitability of this product for specific applications.



# HardieSoffit® Beaded Porch Panels

EFFECTIVE APRIL 2018

**IMPORTANT: FAILURE TO FOLLOW JAMES HARDIE WRITTEN INSTALLATION INSTRUCTIONS AND COMPLY WITH APPLICABLE BUILDING CODES MAY VIOLATE LOCAL LAWS, AFFECT BUILDING ENVELOPE PERFORMANCE AND MAY AFFECT WARRANTY COVERAGE. FAILURE TO COMPLY WITH ALL HEALTH AND SAFETY REGULATIONS WHEN CUTTING AND INSTALLING THIS PRODUCT MAY RESULT IN PERSONAL INJURY. BEFORE INSTALLATION, CONFIRM YOU ARE USING THE CORRECT HARDIEZONE® PRODUCT INSTRUCTIONS BY VISITING HARDIEZONE.COM OR CALL 1-866-942-7343 (866-9-HARDIE)**

## STORAGE & HANDLING:

Store flat and keep dry and covered prior to installation. Installing siding wet or saturated may result in shrinkage at butt joints. Carry planks on edge. Protect edges and corners from breakage. James Hardie is not responsible for damage caused by improper storage and handling of the product.

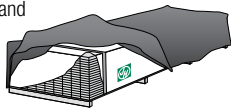

## ⚠ CUTTING INSTRUCTIONS

### OUTDOORS

- Position cutting station so that airflow blows dust away from the user and others near the cutting area.
- Cut using one of the following methods:
  - Best:** Circular saw equipped with a HardieBlade® saw blade and attached vacuum dust collection system. Shears (manual, pneumatic or electric) may also be used, not recommended for products thicker than 7/16 in.
  - Better:** Circular saw equipped with a dust collection feature (e.g. Roan® saw) and a HardieBlade saw blade.
  - Good:** Circular saw equipped with a HardieBlade saw blade.

### INDOORS

- DO NOT grind or cut with a power saw indoors. Cut using shears (manual, pneumatic or electric) or the score and snap method, not recommended for products thicker than 7/16 in.
- DO NOT dry sweep dust; use wet dust suppression or vacuum to collect dust.
  - For maximum dust reduction, James Hardie recommends using the "Best" cutting practices. Always follow the equipment manufacturer's instructions for proper operation.
  - For best performance when cutting with a circular saw, James Hardie recommends using HardieBlade® saw blades.
  - Go to [jameshardiepros.com](http://jameshardiepros.com) for additional cutting and dust control recommendations.

**IMPORTANT:** The Occupational Safety and Health Administration (OSHA) regulates workplace exposure to silica dust. For construction sites, OSHA has deemed that cutting fiber cement with a circular saw having a blade diameter less than 8 inches and connected to a commercially available dust collection system per manufacturer's instructions results in exposures below the OSHA Permissible Exposure Limit (PEL) for respirable crystalline silica, without the need for additional respiratory protection.

If you are unsure about how to comply with OSHA silica dust regulations, consult a qualified industrial hygienist or safety professional, or contact your James Hardie technical sales representative for assistance. James Hardie makes no representation or warranty that adopting a particular cutting practice will assure your compliance with OSHA rules or other applicable laws and safety requirements.

## GENERAL REQUIREMENTS:

- HardieSoffit® beaded porch panels may be installed as a soffit or ceiling over either wood or steel 20 gauge (33 mils) minimum to 16 gauge (54 mils) framing complying with the local building code. See general fastening requirements. Install soffits to nominal 2 x 4 framing members spaced a maximum of 24" on center (fig. 1), with the long dimension perpendicular to the rafter or joist framing.
- All edges must be supported by framing. (fig. 1)
- Install water barriers and air barriers as required by local building codes. James Hardie will assume no responsibility for moisture infiltration.
- Ensure gutters have end caps. Maintain a minimum 1" gap between end caps and siding & trim (fig. 5).
- Install kickout flashing at roof-wall junctions. (fig 6.)
- DO NOT use finish nails.
- James Hardie Building Products provides installation/wind load information for buildings with a maximum mean roof height of 85 feet. For information on installations above 60 feet, please contact JH technical support.

Figure 1

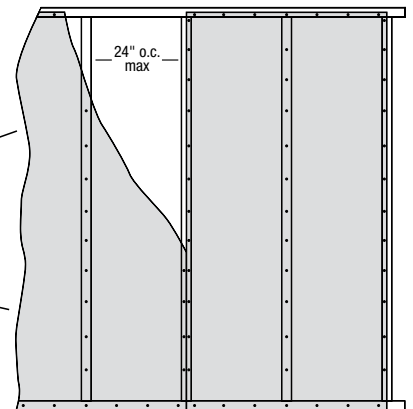
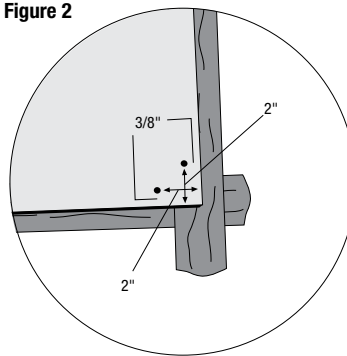

Figure 2



## INSTALLATION:

- HardieSoffit beaded porch panels must be fastened to a solid, nailable substrate such as wood.
- Additional framing may be needed to ensure proper fastening.
- Panels can be installed as shown in figure 1.

### Fastener Positioning

- Position fasteners 3/8" from panel edges and no closer than 2" away from corners (Figure 2).

### Joining Methods

- Panel ends are to be butted together as shown in Figure 3.
- Install panels in moderate contact at ends with or without battens (Figure 4).



Figure 3

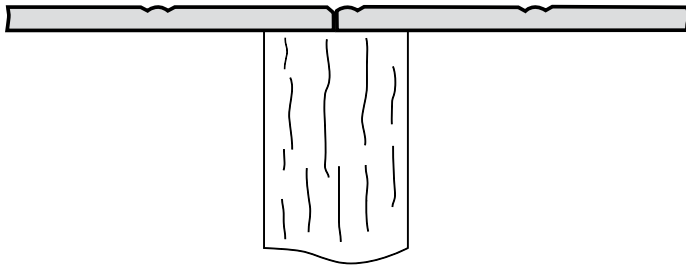

Maintain a minimum 1" gap between gutter end caps and siding & trim.

Figure 5

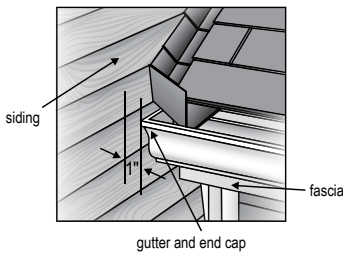

Figure 6

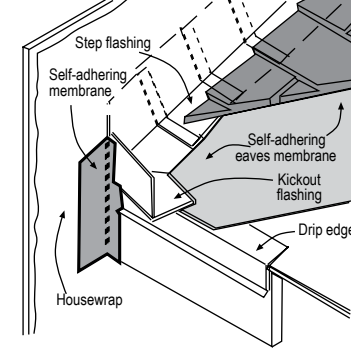
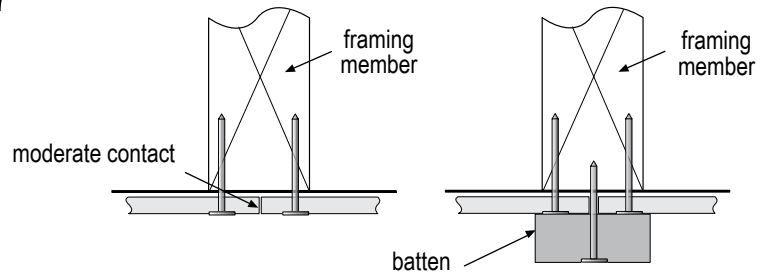

Figure 4



### KICKOUT FLASHING

Because of the volume of water that can pour down a sloped roof, one of the most critical flashing details occurs where a roof intersects a sidewall. The roof must be flashed with step flashing. Where the roof terminates, install a kickout to deflect water away from the siding.

It is best to install a self-adhering membrane on the wall before the subs fascia and trim boards are nailed in place, and then come back to install the kickout.

**Figure 6, Kickout Flashing\*\*** To prevent water from dumping behind the siding and the end of the roof intersection, install a "kickout" as required by IRC code R905.2.8.3 : "...flashing shall be a min. of 4" high and 4" wide." James Hardie recommends the kickout be angled between 100° - 110° to maximize water deflection.

### FASTENER REQUIREMENTS

- For wood frame construction a minimum 4d common nails spaced 8" o.c. at panel edges and intermediate framing members spaced up to 24" on center are suitable in most locations\*.
- For conventional 20-16 ga steel frame construction a minimum No. 8-18 x 0.323" HD x 1" long ribbed bugle screws spaced 6" o.c. at panel edges and intermediate framing members spaced up to 24" on center are suitable in most locations\*.

\*Minimum Basic Wind Speed differs by locality. Where specified levels of wind resistance are required, refer to applicable Building Code Compliance Reports.

### GENERAL FASTENING REQUIREMENTS

Fasteners must be corrosion resistant, galvanized, or stainless steel. Electro-galvanized are acceptable but may exhibit premature corrosion. James Hardie recommends the use of quality, hot-dipped galvanized nails. James Hardie is not responsible for the corrosion resistance of fasteners. Stainless steel fasteners are recommended when installing James Hardie® products near the ocean, large bodies of water, or in very humid climates.

Manufacturers of ACQ and CA preservative-treated wood recommend spacer materials or other physical barriers to prevent direct contact of ACQ or CA preservative-treated wood and aluminum products. Fasteners used to attach HardieTrim Tabs to preservative-treated wood shall be of hot dipped zinc-coated galvanized steel or stainless steel and in accordance to 2009 IRC R317.3 or 2009 IBC 2304.9.5

- Consult applicable product evaluation or listing for correct fasteners type and placement to achieve specified design wind loads.
- NOTE: Published wind loads may not be applicable to all areas where Local Building Codes have specific jurisdiction. Consult James Hardie Technical Services if you are unsure of applicable compliance documentation.
- Drive fasteners perpendicular to siding and framing.
- Fastener heads should fit snug against siding (no air space).
- NOTE: Whenever a structural member is present, HardiePlank should be fastened with even spacing to the structural member. The tables allowing direct to OSB or plywood should only be used when traditional framing is not available.
- **Do not use aluminum fasteners, staples, or clipped head nails.**

### PNEUMATIC FASTENING

James Hardie products can be hand nailed or fastened with a pneumatic tool. Pneumatic fastening is highly recommended. Set air pressure so that the fastener is driven snug with the surface of the siding. A flush mount attachment on the pneumatic tool is recommended. This will help control the depth the nail is driven. If setting the nail depth proves difficult, choose a setting that under drives the nail. (Drive under driven nails snug with a smooth faced hammer - Does not apply for installation to steel framing).

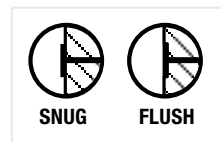

<p><b>DO NOT</b></p> <p><b>UNDER DRIVE</b></p>	<p><b>DO NOT</b></p> <p><b>OVER DRIVE</b></p>	<p><b>DO NOT USE</b></p> <p><b>ALUMINUM FASTENERS</b></p>
<p><b>IF, THEN</b></p> <p><b>WOOD FRAME</b></p> <p>HAMMER FLUSH</p>	<p><b>IF, THEN ADDITIONAL NAIL</b></p> <p><b>STEEL FRAME</b></p> <p>REMOVE &amp; REPLACE</p>	<p><b>DO NOT USE</b></p> <p><b>CLIPPED HEAD NAILS</b></p>
<p><b>FACE NAIL</b></p> <p>COUNTERSINK &amp; FILL</p>		<p><b>DO NOT USE</b></p> <p><b>STAPLES</b></p>

\*\*The illustration (figure 6) was reprinted with permission of THE JOURNAL OF LIGHT CONSTRUCTION. For subscription information, visit www.jlconline.com.

Figure 3

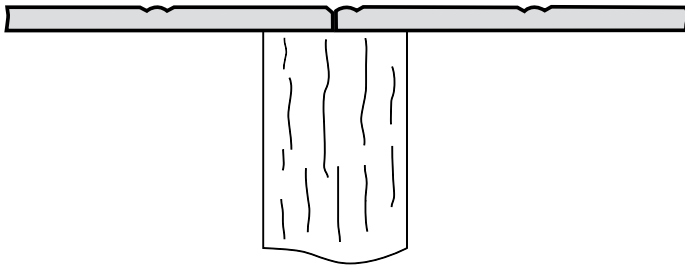

Maintain a minimum 1" gap between gutter end caps and siding & trim.

Figure 5

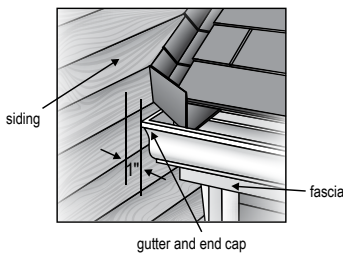

Figure 6

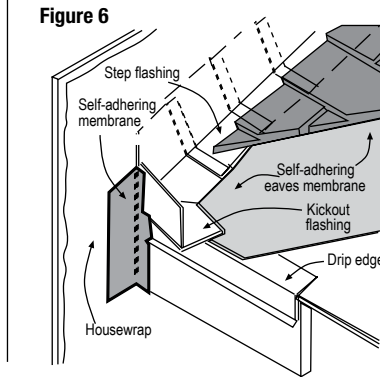
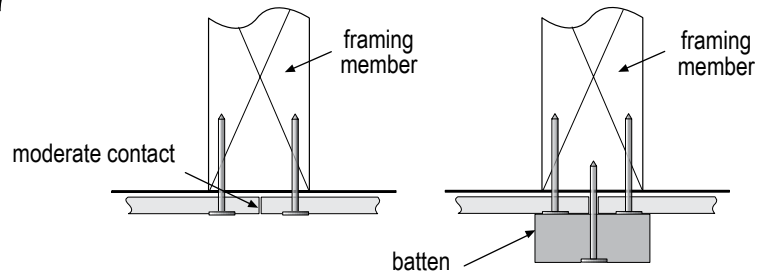

Figure 4



### KICKOUT FLASHING

Because of the volume of water that can pour down a sloped roof, one of the most critical flashing details occurs where a roof intersects a sidewall. The roof must be flashed with step flashing. Where the roof terminates, install a kickout to deflect water away from the siding.

It is best to install a self-adhering membrane on the wall before the subfascia and trim boards are nailed in place, and then come back to install the kickout.

**Figure 6, Kickout Flashing™** To prevent water from dumping behind the siding and the end of the roof intersection, install a "kickout" as required by IRC code R905.2.8.3 : "...flashing shall be a min. of 4" high and 4" wide." James Hardie recommends the kickout be angled between 100° - 110° to maximize water deflection.

### FASTENER REQUIREMENTS

- For wood frame construction a minimum 4d common nails spaced 8" o.c. at panel edges and intermediate framing members spaced up to 24" on center are suitable in most locations\*.
- For conventional 20-16 ga steel frame construction a minimum No. 8-18 x 0.323" HD x 1" long ribbed bugle screws spaced 6" o.c. at panel edges and intermediate framing members spaced up to 24" on center are suitable in most locations\*.

\*Minimum Basic Wind Speed differs by locality. Where specified levels of wind resistance are required, refer to applicable Building Code Compliance Reports.

### GENERAL FASTENING REQUIREMENTS

Fasteners must be corrosion resistant, galvanized, or stainless steel. Electro-galvanized are acceptable but may exhibit premature corrosion. James Hardie recommends the use of quality, hot-dipped galvanized nails. James Hardie is not responsible for the corrosion resistance of fasteners. Stainless steel fasteners are recommended when installing James Hardie® products near the ocean, large bodies of water, or in very humid climates.

Manufacturers of ACQ and CA preservative-treated wood recommend spacer materials or other physical barriers to prevent direct contact of ACQ or CA preservative-treated wood and aluminum products. Fasteners used to attach HardieTrim Tabs to preservative-treated wood shall be of hot dipped zinc-coated galvanized steel or stainless steel and in accordance to 2009 IRC R317.3 or 2009 IBC 2304.9.5

- Consult applicable product evaluation or listing for correct fasteners type and placement to achieve specified design wind loads.
- NOTE: Published wind loads may not be applicable to all areas where Local Building Codes have specific jurisdiction. Consult James Hardie Technical Services if you are unsure of applicable compliance documentation.
- Drive fasteners perpendicular to siding and framing.
- Fastener heads should fit snug against siding (no air space).
- NOTE: Whenever a structural member is present, HardiePlank should be fastened with even spacing to the structural member. The tables allowing direct to OSB or plywood should only be used when traditional framing is not available.
- **Do not use aluminum fasteners, staples, or clipped head nails.**

### PNEUMATIC FASTENING

James Hardie products can be hand nailed or fastened with a pneumatic tool. Pneumatic fastening is highly recommended. Set air pressure so that the fastener is driven snug with the surface of the siding. A flush mount attachment on the pneumatic tool is recommended. This will help control the depth the nail is driven. If setting the nail depth proves difficult, choose a setting that under drives the nail. (Drive under driven nails snug with a smooth faced hammer - Does not apply for installation to steel framing).

<p><b>SNUG</b>      <b>FLUSH</b></p>		<p><b>ALUMINUM FASTENERS</b></p> <p><b>CLIPPED HEAD NAILS</b></p> <p><b>STAPLES</b></p>
<p><b>DO NOT</b></p> <p><b>UNDER DRIVE</b></p>	<p><b>DO NOT</b></p> <p><b>OVER DRIVE</b>      <b>SLANT</b></p>	
<p><b>IF, THEN</b></p> <p><b>WOOD FRAME</b></p> <p><b>HAMMER FLUSH</b></p>	<p><b>IF, THEN ADDITIONAL NAIL</b></p> <p><b>FACE NAIL</b></p> <p><b>COUNTERSINK &amp; FILL</b></p>	
<p><b>STEEL FRAME</b></p> <p><b>REMOVE &amp; REPLACE</b></p>		

\*\*The illustration (figure 6) was reprinted with permission of THE JOURNAL OF LIGHT CONSTRUCTION. For subscription information, visit www.jlconline.com.