

FLOOR DOOR - ANGLED EXISTING FLOOR DOOR - FLDE

The retrofit floor door is ready to be installed in an existing floor opening.

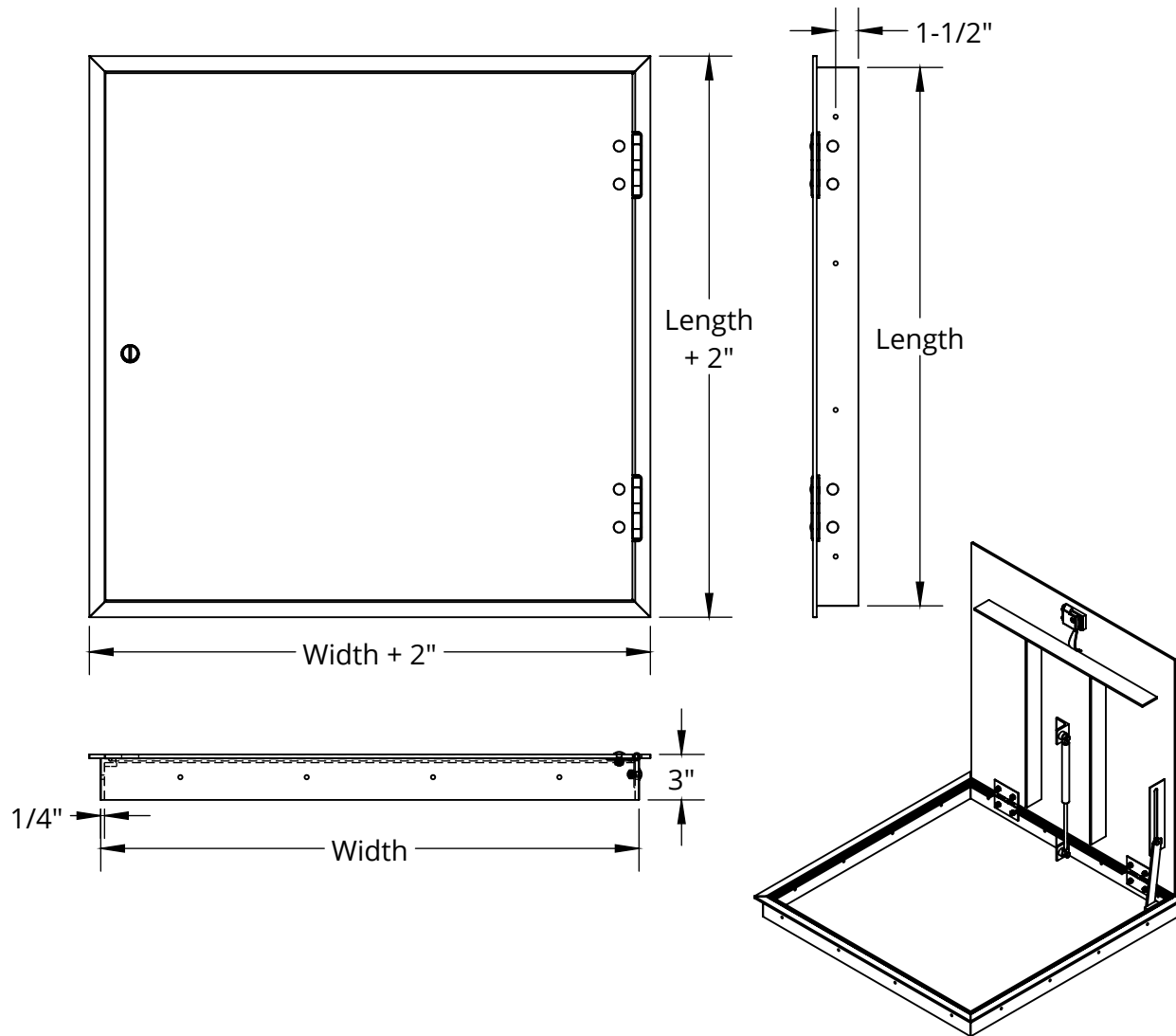

SPECIFICATIONS:

Frame Material: 1/4" extruded aluminum

Door Material: Reinforced 1/4" diamond aluminum plate.

Standard Finish: Mill

Frame Construction: Pre-drilled .28" dia mounting holes for 1/4" hardware (by others) 1-1/2" from bottom of frame

Latch: 304 Stainless steel slam latch with flush key operator on exterior and handle opener on inside. Removable stainless 18-8 threaded plug and 5/16" steel square key included.

Hinge: 304 Stainless steel

Spring: 304 Stainless steel gas assist opener

Hold Open Arm: Stainless steel automatically locks door open to 90°

Load: 300 lb/sq ft pedestrian live load

Sizes: Minimum 23" x 23", Maximum 48" x 48"

ORDER SIZE = FRAME INSIDE DIMENSION

QTY	MODEL	ORDER SIZE		EXISTING OPENING		APPROX. WEIGHT
		WIDTH	LENGTH			
	FLDE-2323S	23"	23"	24"	24"	60
	FLDE-2335S	23"	35"	24"	36"	76
	FLDE-2929S	29"	29"	30"	30"	81
	FLDE-2947S	29"	47"	30"	48"	115
	FLDE-3535S	35"	35"	36"	36"	100
	FLDE-3547S	35"	47"	36"	48"	118
	FLDE-4141S	41"	41"	42"	42"	120
	FLDE-4747S	47"	47"	48"	48"	154

Custom Size

ADDITIONAL OPTIONS:

S.S. Padlock Tab on Top in addition to Standard Latch - PT



9702 Newton Ave S. Bloomington, MN 55431 | Many Locations Nationwide

800-554-6077
 sales@activarcpg.com
 www.activarcpg.com

Distributor:

Project:

Contractor:

Approved By:

Date:

Architect:

Scale: N/A

Pages: 1 of 2

Item #:

FLOOR DOOR - ANGLED EXISTING FLOOR DOOR - FLDE

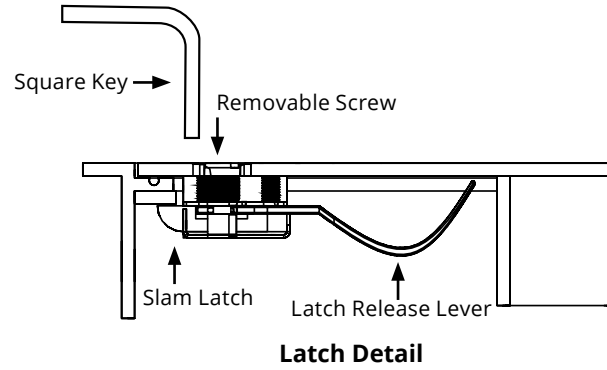
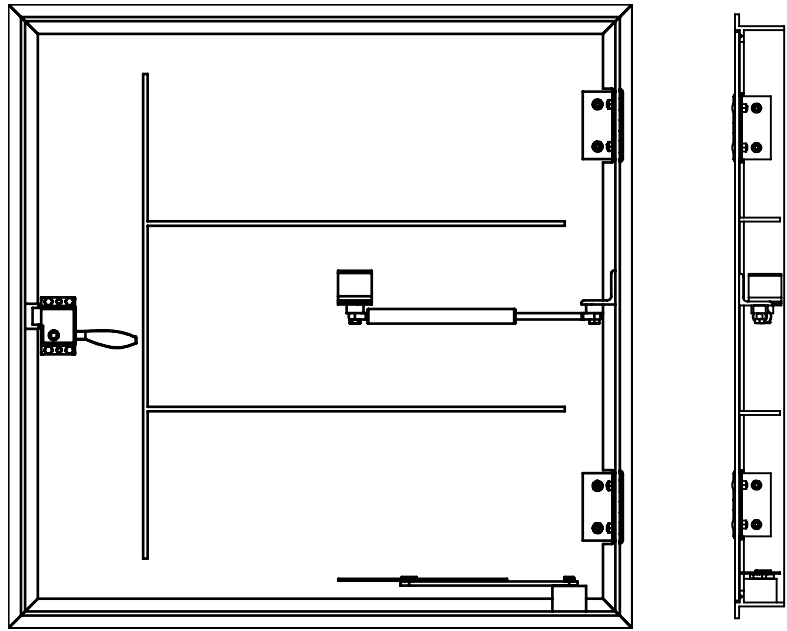

Padlock Tab Detail

