

GENERAL:

Before any installation is started, be sure to verify:

- Model of grate and frame
- Size of grate and frame
- Product color
- That there are no visual defects or damage from shipment.

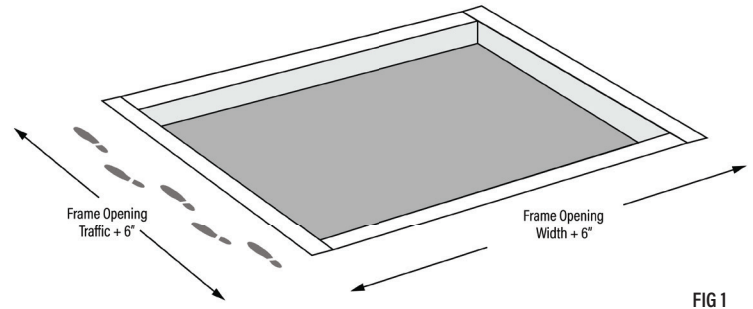

FIG 1

***NOTE:** No returns will be accepted after the material has been installed.
Failure to follow these installation instructions may void your warranty.

INSTALLATION:

Activ-Grate™ Shallow Recessed Installation Instructions:

1. Prepare a recess in the concrete flooring (block out) where the grate will be installed. The recess should be at least 1" deeper than the total height of your grate and frame; consult your shop drawing for proper depth. Block out an area 6" wider than the outside dimensions of the frame in both directions. (FIG 1) This will allow 3" on all sides to maneuver the frames into place.
2. Place the frame in the recess. Use shims to raise frame to exact height of finished floor and level the frame. All frame corners are mitered.
3. Pour concrete (using non-shrinking grout - sand coat is not recommended) around perimeter of frame. There must not be any free space between the grate and frame (or the pan if applicable) and the liquid cement.
4. Level the concrete. Frames without pans use a board slightly smaller than the frame opening and level the concrete in each section to be flush with the leg of the frame. It is important the concrete (using non-shrinking grout) is smooth and level with the lip of the frame so the grate lies perfectly flat and will not shift.
5. Ensure there will be no traffic of any kind on the frames during the drying period of the non-shrinking grout.
6. Before the concrete hardens, verify that the dimensions are correct and frame is square and level.
7. After concrete has hardened, install plywood into the recess to fully protect the frame edges until just before the entrance is opened and the grates are installed.
8. Clean the frames and recess before installing grates; debris cannot be tolerated between the frame and grate.
9. Remove the protective wood from the recess, and clean the recess thoroughly. Any debris will create irregularities in the recess that will prevent the grate from lying flat
10. Place the grate in the recess. If there are multiple sections, refer to the shop drawings for proper placement
11. Clean the grate with a vacuum in preparation for use.
12. Remove the protective wood from the recess, and clean the recess thoroughly. Any debris will create irregularities in the recess that will prevent the grate from lying flat.

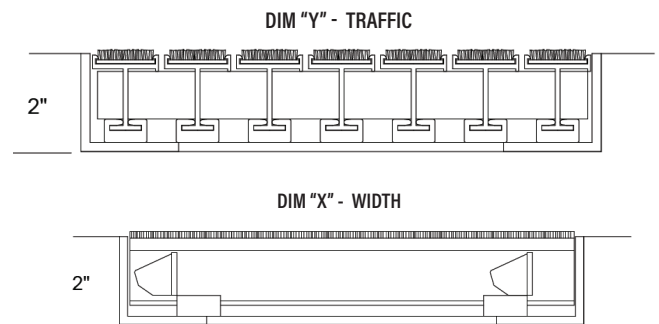

Pictured: EG900 EFRB9

FIG 2

13. Place the grate in the recess. If there are multiple sections, refer to the shop drawings for proper placement.
14. Clean the grate with a vacuum in preparation for use.

Activ-Grate™ Cast-In Place Installation Instructions:

1. A blocked out area of at least 2" (51 mm) deep and 6" (152 mm) larger than the frame dimensions (FIG 1). This allows for positioning of the frame, and space for the mortar to be packed behind the frame to insure it will be held firmly in place.

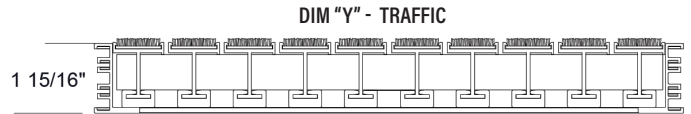

2. After consulting the shop drawings, assemble the frame using the corner keys provided (FIG 4). If the size of the frame requires multiple sections, join the marked frame sections with the roll pins provided. Place the frame in the opening, and shim as necessary to locate the exposed top of the frame at the height of the finished floor. Be sure to put the correct side up. The depth from the top of the frame to the lip should be 1.75". Check corner to corner dimensions to be sure frame angles are correct.

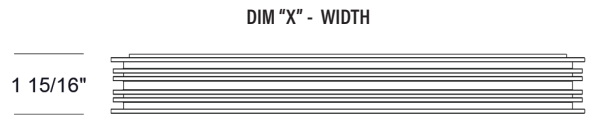

Pictured: EG900 EFRC9 FIG 3

3. Pour cement mortar around the edges of the frame, and in the center in sufficient quantity to finish level with the inside lips of the frame. Work the mortar into the outside edges of the frame, and finish to the correct height to allow for the final floor finish. It may be necessary to insert spreaders to prevent long frame sections from bowing inward. Using the inside lips of the frame as a screed, level the bed for the grate. This is critical for the grate to sit correctly in the frame.

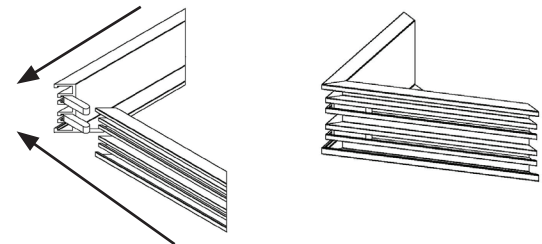

FIG 4

4. Before mortar sets, re-check the frame to make sure it is plumb, and the correct size. Check the sides to insure they have remained parallel, and the corner angles are correct. **The grate will not fit in the frame if it is not installed exactly as indicated on the shop drawings.**
5. When the mortar has hardened, install plywood or other material in the recess to protect the edges of the frame until it is time to install the grates. The grates should not be installed until the building is ready for use, to prevent soiling or accidental damage.
6. Remove the protective wood from the recess, and clean the recess thoroughly. Any debris will create irregularities in the recess that will prevent the grate from lying flat.
7. Place the grate in the recess. If there are multiple sections, refer to the shop drawings for proper placement.
8. Clean the grate with a vacuum in preparation for use.



9702 Newton Ave S. Bloomington, MN 55431 | Many Locations Nationwide

800-554-6077 952-835-2218 sales@activarcpg.com www.activarcpg.com

Installation & Maintenance Guide

Activ-Grate™ Deep Pit Installation Instructions:

1. A blocked out area at least 4 1/4 " deep and 6" larger than the frame dimensions must be provided in the floor where the frame is to be installed (FIG 1). This allows for positioning of the frame, and space for the mortar to be packed behind the frame to insure it will be held firmly in place. Complete all plumbing work for drain and trap, if required, before pouring concrete and installing frame.
2. After consulting the shop drawings, assemble the frame using the corner keys provided (FIG 6). If the size of the frame requires, join the marked frame lengths together with the roll pins provided.
3. Place the frame in the opening, and shim as necessary to locate the exposed top of the frame at the height of the finished floor. Check corner to corner dimensions to be sure frame angles are correct, and the unit is plumb.
4. Pour cement mortar around the edges of the frame. Work the mortar into the outside edges of the frame to provide proper support for the frame. Finish around the outside of the frame to the correct height to allow for the final floor finish. It may be necessary to insert spreaders to prevent long frame sections from bowing inward.
5. Pour cement mortar into the center of the frame, and level it to the bottom of the frame (or taper down to drain area) to a minimum depth of 4 1/4" at outside edges. (Drain port and plumbing by others).
6. When the mortar has hardened, install plywood or other material in the recess to protect the edges of the frame until it is time to install the grates. The grates should not be installed until the building is ready for use, to prevent soiling or accidental damage.
7. When ready to install the entrance grate with adjustable height cross supports, remove the protective wood or other filler from the recess, and clean the recess thoroughly. Any debris will create irregularities in the recess that will prevent the grate from lying flat.
8. Loosely attach all the support legs to the full cross supports as using bolts as shown in FIG 7.

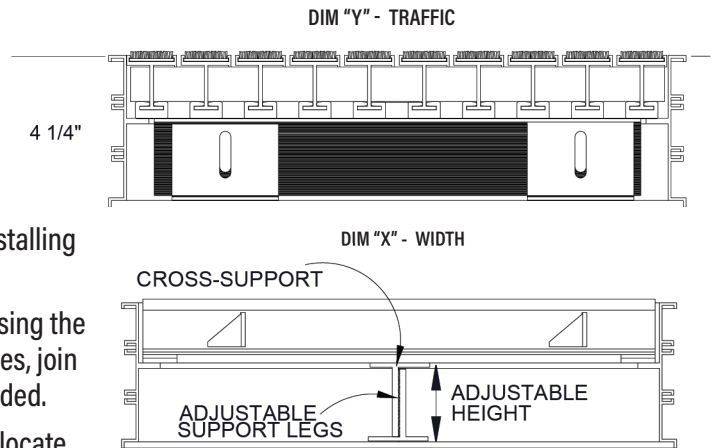

FIG 5

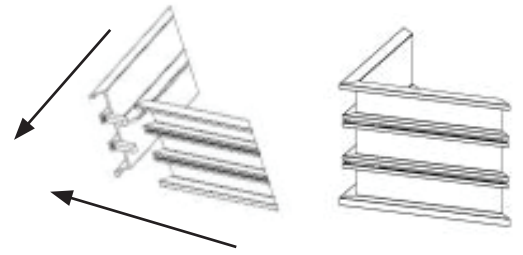

FIG 6



FIG 7



9702 Newton Ave S. Bloomington, MN 55431 | Many Locations Nationwide

800-554-6077 952-835-2218 sales@activarcpg.com www.activarcpg.com

Installation & Maintenance Guide

9. Set the cross support(s) into position(s), making sure to space approximately 3 feet apart, as shown in FIG 8. Note: in some cases, cross-supports may be individually labeled and must be in the correct location as shown on the drawings.
10. Adjust the height of the support legs on the ends of the cross supports so they sit level with the bottom of the grating cross-supports. (FIG 9) Level each support leg by tightening the bolts. If pit floor is sloped, shims may be needed to level the support legs. It is necessary that all support legs and cross supports be installed correctly to insure proper support of the grate.
11. Drill pilot holes into pit floor through each hole provided in the foot of the support legs.
12. Secure all support legs to the bottom of the pit with masonry fasteners. (FIG 9)
13. It is important that the cross supports and framing structure be flat and level within 1/8" over 10 feet to ensure proper installation.
14. Place the grate in the recess on top of the cross supports. If there are multiple sections, refer to the shop drawings for proper placement.
15. Clean the grate with a vacuum in preparation for use.

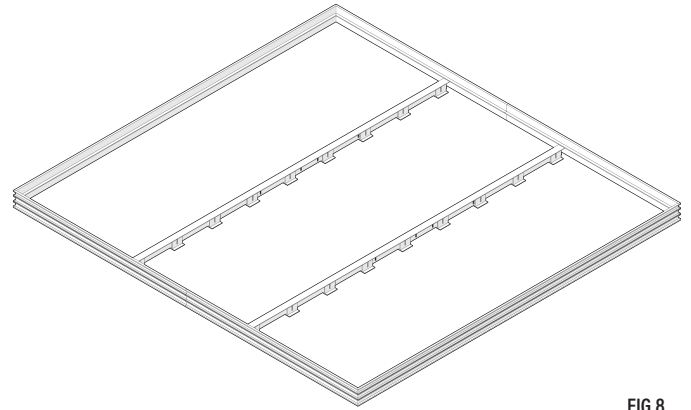

FIG 8

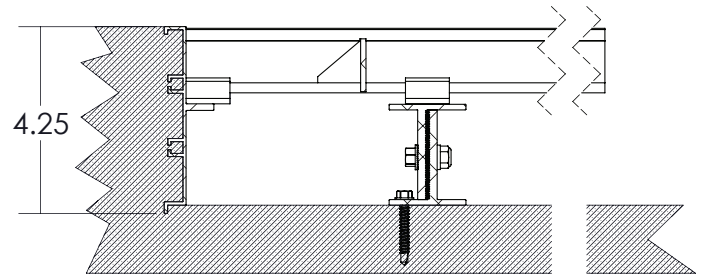

FIG 9

MAINTENANCE:

The location and traffic load will determine the frequency of cleaning required. If damaged, treads can be replaced at www.activarcpq.com

ANODIZED ALUMINUM CLEANING:

Never use concentrated acidic or alkaline base solutions, many detergents fall into this category. Wash often to keep contaminants from forming or building up. Clean anodized aluminum with mild dish washing liquid with a soft towel or sponge. Always try a test small area first. Do not use steel or brass wool, wire brushes, polishing wheels or polishing compounds. Rinse thoroughly and completely with direct fresh water. The important point is to clean and rinse your anodized aluminum well. When using metal protection products, be sure they are formulated for anodized aluminum. In areas with corrosive environment or where ice-melting chemicals are used, the frame can be waxed with a high quality automotive wax for additional protection.

CARPET TREAD MAINTENANCE:

It is important to begin this plan when the mat is new, for the longer the soil or stain remains in the carpet, the more difficult it is to remove. The type and schedule of maintenance depends on the location, amount of traffic and type of stain. On a weekly basis: The sections should be removed from their recess and this area cleaned. Our recommendations: Inspect regularly for spots and stains to reduce the possibility of them becoming permanent. If the spill is a liquid, blot up as much as possible with a clean, soft absorbent paper towel or cloth. If the spill is semi-solid, scrape with a spoon or spatula and then blot with a damp sponge. Work from the edge of the spot to the center to keep the stain from spreading. Two types of spot remover can be used. For oily stains such as tar, paint, grease, etc., a non-flammable dry cleaning solvent works best. Caution should be taken to first test for color fastness. Put a few drops in an inconspicuous area, then press the area with a clean cloth for 10 seconds. If there is any evidence of loose dye, discontinue use. For most other spills such as coffee, tea, pet stains, etc., a dry soil extractor such as Milliken's "Capture" works well. Follow manufacturer's directions for those products.

VACUUM SCHEDULE: A good heavy duty vacuum cleaner with a rotating brush is the most effective way to routinely clean the carpet in your entrance grating. By vibrating the fibers, this type of vacuum not only cleans the surface of the carpet, but also removes soil that is embedded into the pile. It aids in keeping the pile upright for longer lasting beauty. The heaviest traffic areas should be vacuumed daily, and lighter traffic areas as infrequently as weekly. If removable, mat or grating sections should be removed from their recess and this area cleaned periodically to prevent buildup of salt, dirt and sand which can cause unevenness.

CARPET CLEANING SCHEDULE: Carpet should be cleaned when vacuuming will no longer remove the soil. This may be monthly, quarterly, or longer depending on soil and traffic conditions. Systems such as aerosols, foams, hot water extraction, or shampoo will work, but sometimes they leave sticky detergent residue that will accelerate re-soiling. Be extremely careful when selecting a method of this type. We recommend a dry system, such as Milliken's "Capture" for several reasons: slower re-soiling, convenience - carpet remains dry allowing you to clean when and where you want, and safe - no possible carpet damage from dye bleeding or wet carpet or floors to cause slipping.

TUFF TREAD MAINTENANCE:

It is important to begin this plan when the mat is new, for the longer the soil or stain remains in the carpet, the more difficult it is to remove. On a weekly basis: The sections should be removed from their recess and this area cleaned. The mats or grates may then be reinstalled and the Tuff Tread cleaned in the same manner as any other carpet mat—with a daily vacuuming. The mats can also be turned upside down to remove sand or hosed off using a regular garden hose or high pressure washer. Tuff Tread can handle pressures of up to 1,000 lbs/inch. There are no known cleaning chemicals that can harm the fibers of Tuff Tread. Due to the construction of Tuff Tread, threads may become trapped in the fibers of the mat. They can easily be removed either by hand, or with a small coarse wire brush, such as used in animal grooming.

SERRATED ALUMINUM TREAD MAINTENANCE:

On a weekly basis: The sections should be removed from their recess and this area cleaned. The mats may then be reinstalled and the tread cleaned with a damp mop, using a mild detergent and water, to remove soil. A stiff bristle brush is helpful for caked on mud.

SERRATED VINYL TREAD MAINTENANCE:

On a weekly basis: The sections should be removed from their recess and this area cleaned. The mats may then be reinstalled and the vinyl cleaned with a damp mop, using a mild detergent and water, to remove soil. A stiff bristle brush is helpful for caked on mud. Avoid using strong solvents, especially petroleum based, as they may discolor or soften the vinyl tread surface.

VINYL ABRASIVE TREAD MAINTENANCE:

On a weekly basis: The sections should be removed from their recess and this area cleaned. The mats or grates may then be reinstalled and the vinyl abrasive cleaned using a vacuum or broom. DO NOT use any hydrocarbon solvents such as kerosene, paint thinner or acetone, as these will damage the vinyl abrasive tread.



9702 Newton Ave S. Bloomington, MN 55431 | Many Locations Nationwide

800-554-6077 952-835-2218 sales@activarcpq.com www.activarcpq.com

Installation & Maintenance Guide