

## ACCESS PANEL - EXTERIOR GALVANNEAL WITH MORTISE LOCK - XTG

Select this locking exterior access panel design with energy efficiency in mind. 2 inches of polyisocyanurate provides an R-value of 13, and dual layered gasketing provides the weather-resistance you need. Door opens to 170°.

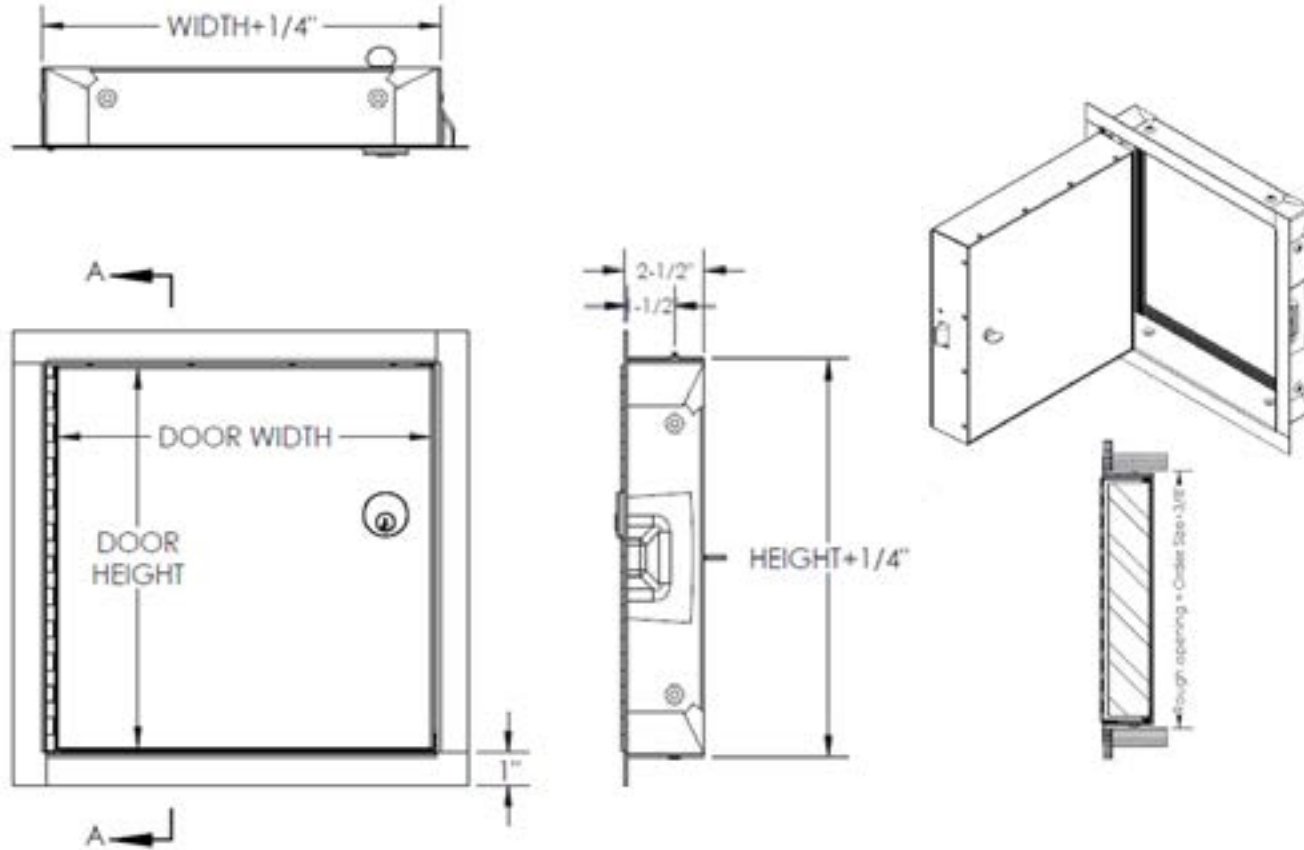

### SPECIFICATIONS:

- Exterior Frame Material:** 17 ga galvalneal steel
- Door Panel Material:** 20 ga galvalneal steel
- Standard Finish:** White powder coat
- Hinge:** Continuous steel rod hinge. Opens to 170°
- Gasketing:** EPDM sponge rubber
- Insulation:** 2" Polyisocyanurate insulation
- Latch:** (U4) Mortise slam lock.  
Up to 30" x 30" will have 1 mortise latch, over 30" in height will have 2 latches.
- Sizes:** Minimum 8" x 8", Maximum 48" x 48"
- Clear Opening:** Width minus 1-1/4" x Height minus 1-1/4"

### OPTIONS:

- Optional Material:** 16 ga. 304 Stainless Steel #4 finish
- Optional Latches:** (U3) Mortise slam prep—rubber gromet included
- Additional Options:** Other powder coat colors

- NOTES:** Order size W x H = Door size  
Rough opening size = order size + 3/8"

### MADE-TO-ORDER XTG - EXAMPLE: 9XTG-2424U4W

| QTY | MODEL | MATERIAL                     | WIDTH | HEIGHT | LATCH / LOCK  | PAINT FINISH     |
|-----|-------|------------------------------|-------|--------|---|------------------|
|     | 9XT   | G Galvalneal                 |       |        | U3 Mortise Lock Prep for Lock by Others: Prepped for Kaba Ilco 7205SC1, 1-1/4" Long Mortise Cylinder with Standard Cam. Cylinders by Others require Brass Ring - PN 0646. | W White (std)    |
|     |       | S Stainless Steel # 4 Finish |       |        | U4 Mortise Lock Installed: Kaba Ilco 7205SC1, 1-1/4" Long Mortise Cylinder with Standard Cam (PN 06431). Includes 2 Keys (PN 06431-KEY).                                  | G Gray           |
|     |       |                              |       |        |   | Other Color Code |

It is the responsibility of the customer to communicate specifications and product performance requirements that are needed for their application. This document is intended to convey potential product configurations and offerings. It is not to be used to imply or represent a specification or rating, of finished products shipped. Detailed, specific submittals can be created upon request. It is the responsibility of the customer to specify product accordingly to comply with local laws, codes, and ordinances.



**JL INDUSTRIES**

9702 Newton Avenue S, Bloomington, MN 55431

800-554-6077  
sales@activarcpg.com  
www.activarcpg.com

|              |             |              |  |
|--------------|-------------|--------------|--|
| Distributor: |             | Project:     |  |
| Contractor:  |             | Approved By: |  |
| Date:        |             | Architect:   |  |
| Scale: N/A   | Page 1 of 1 | Item#:       |  |