

SUBMITTAL: FD2WI™ - 2 HOUR FIRE-RATED ACCESS PANEL FOR WALLS WITH INWARD OPENING DOOR

The Maxam fire-rated access panel for use in walls where control of temperature rise and heat transmission is required. Designed without the use of springs, allowing easier access through the door opening.

Materials: Satin finish galvaneal steel or 304 stainless steel.

Frame: 16 ga up to and including 30" x 48" (762 mm x 1219 mm), larger sizes are 14 ga. Depth (D) = 3 1/2" (89mm).

Flange: Exterior flange width is 7/8" (22mm). Overall width 1-1/2" (38 mm).

Door Panel: 18 gauge, 22 gauge liner, with inside pull handle.

Insulation: The door panel contains 1 1/2" of high temperature insulation material.

Finishes: Rust-inhibitive off-white prime coat or # 4 polished stainless steel finish on exterior surface.

Hinges: Concealed continuous piano hinge allows the door panel to open inward 90°. The hinge is placed on the "H" dimension.

Panel Closer: Concealed door closer allows the door panel to be self-closing and self-latching from an open position of approx. 90° as required by NFPA 80.

Latch: The standard factory installed latch is a flush mount 1/4" allen key (A). The interior latch release is standard on doors.

Sizes: Minimum size 16" x 16", maximum size 48" x 60".

Clear Opening: Width minus 3-1/4", Height minus 1-1/2".



STEP 1: SELECT MODEL NUMBER AND QUANTITY ON CHART—PAGE 2 OR ENTER CUSTOM SIZE BELOW

___ " Width x ___ " Height - **Rough opening is order size .**

Frame size is 1/4" less than Width and Height

STEP 2: SELECT MATERIAL

___ Galvaneal steel with off-white primer

___ Stainless steel with #4 finish on exterior

OPTIONAL FEATURES AT ADDITIONAL COST

___ (K) Smoke Gasket - listed by Intertek Warnock Hersey. See Testing Standards in red box.

Single Latch - Select One Option:

___ Raised knurled knob (KK) ___ 1-1/8" mortise prep complete w/mortise cylinder (MPI) ___ 1-1/8" mortise prep only (MP)

Dual Latches - Select One Option:

___ Central two point latch operator with handle (2P)

___ 1-1/8" mortise prep complete with mortise cylinder (MPI) ___ Top or ___ Bottom Second Latch will be Allen Key (A)

___ 1-1/8" mortise prep only (MP) ___ Top or ___ Bottom Second Latch will be Allen Key (A)



___ (2) 1-1/8" mortise preps only (MP) top and bottom

___ (2) 1-1/8" mortise preps complete with (2) mortise cylinders (MPI) top and bottom



Intertek Warnock Hersey:
 2 Hour Fire Rating Vertical Installation only
 Temp Rise Max: 139°C / 250° F at 30 Min 250° C / 450° F at 60 Min
Testing Standards:
Vertical: ASTM 252, UL 10(b), CAN/ULC S104

Optional Smoke Gasket Testing Standards:
 UL 1784 per NFPA 105, ASTM E152, CAN4 S106, UBC 7-2, UL 10 (b) NFPA 252 (90- minute)

LATCH AND LOCK OPTIONS		
Standard 1/4" Allen Key	Optional Mortise Lock (MPI)	Optional Knurled Knob (KK)
		

 JL INDUSTRIES	Distributor:	Quantity:
	Contractor:	Approved By:
	Model #:	Architect:
	Project:	Date: © 2023 Activar Construction Products Group, Inc.
HEADQUARTERS: 9702 NEWTON AVE S, BLOOMINGTON, MN 55431 PH: 800-554-6077 EMAIL: SALES@ACTIVARCPG.COM WWW.ACTIVARCPG.COM MANUFACTURING: BLOOMINGTON, MN & COMMERCE, CA WAREHOUSES: SEE WEBSITE FOR LOCATIONS 1/16/2023		

QTY	Rough Opening is Order Size W x H Hinge Side is "H"		No. of Latches/ Locks	Weight in Kgs	Weight in Lbs.	
	Inches	Metric (mm)				
	Width x Height	Width x Height				
	FD2WI-1616	16 x 16	406 x 406	1	8	17
	FD2WI-1624	16 x 24	406 x 610	1	10	23
	FD2WI-1818	18 x 18	457 x 457	1	9	20
	FD2WI-1824	18 x 24	457 x 610	1	11	25
	FD2WI-1830	18 x 30	457 x 762	1	13	29
	FD2WI-1836	18 x 36	457 x 914	1	16	35
	FD2WI-1848	18 x 48	457 x 1219	1	20	45
	FD2WI-2020	20 x 20	508 x 508	1	10	23
	FD2WI-2024	20 x 24	508 x 610	1	12	26
	FD2WI-2030	20 x 30	508 x 762	1	15	32
	FD2WI-2036	20 x 36	508 x 914	1	17	38
	FD2WI-2040	20 x 40	508 x 1016	1	19	42
	FD2WI-2222	22 x 22	559 x 559	1	12	27
	FD2WI-2230	22 x 30	559 x 762	1	15	34
	FD2WI-2236	22 x 36	559 x 914	1	19	41
	FD2WI-2424	24 x 24	610 x 610	1	14	30
	FD2WI-2430	24 x 30	610 x 762	1	16	36
	FD2WI-2436	24 x 36	610 x 914	1	20	43
	FD2WI-2448	24 x 48	610 x 1219	2	25	55
	FD2WI-3030	30 x 30	762 x 762	1	20	43
	FD2WI-3036	30 x 36	762 x 914	2	23	51
	FD2WI-3048	30 x 48	762 x 1219	2	30	66
	FD2WI-3232	32 x 32	813 x 813	2	22	49
	FD2WI-3636	36 x 36	914 x 914	2	27	60
	FD2WI-3648	36 x 48	914 x 1219	2	35	77
	FD2WI-3660	36 x 60	914 x 1524	2	44	97
	FD2WI-4040	40 x 40	1016 x 1016	2	33	72
	FD2WI-4048	40 x 48	1016 x 1219	2	38	84
	FD2WI-4060	40 x 60	1016 x 1524	2	48	105
	FD2WI-4848	48 x 48	1219 x 1219	2	44	98
	FD2WI-4860	48 x 60	1219 x 1524	2	55	122

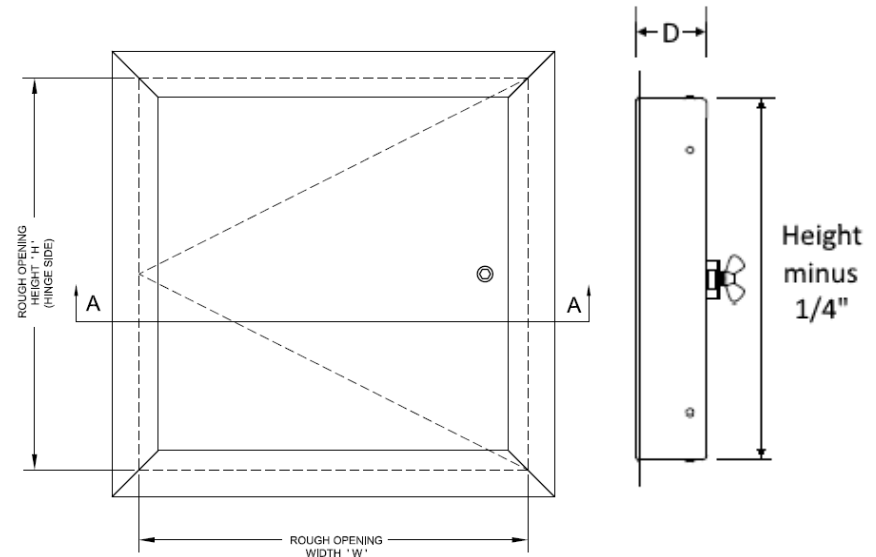
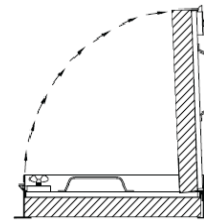
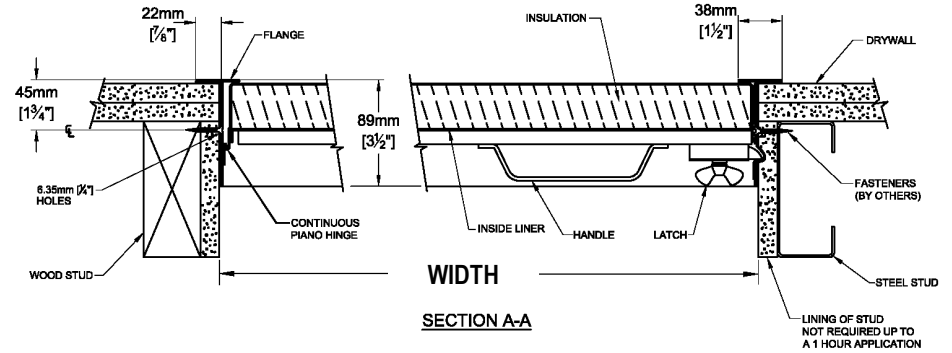

Clear Opening = Width minus 3-1/4", Height minus 1-1/2"

Second dimension given is the hinge side (shown in red) unless otherwise specified.

Other sizes available upon request for all Models.