

## ROOF HATCH - DIAMOND SERIES™ - RHDA ALUMINUM

The Diamond Series Roof Hatch in aluminum is designed for safe and easy roof access with R-6 insulation to reduce building energy costs. Our unique, patented "Diamond Grip®" simplifies installation by securing the roof membrane without tools.

Ladder Access Hatch

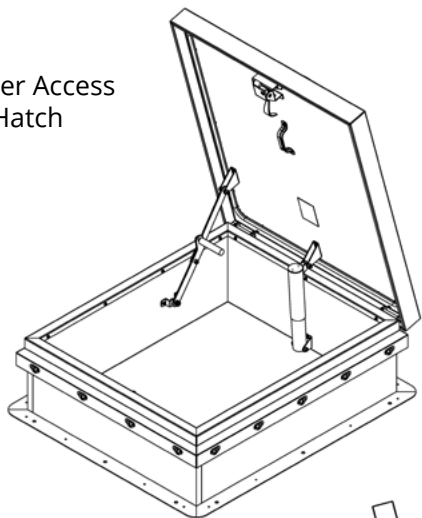

Stair Access Hatch

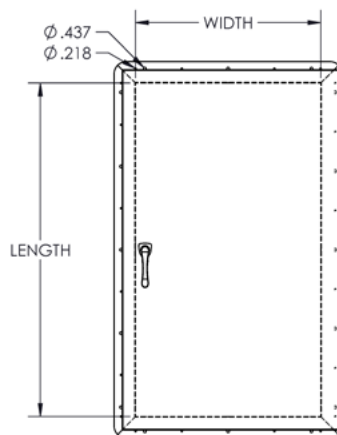
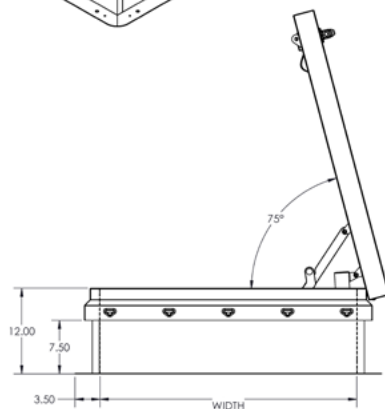
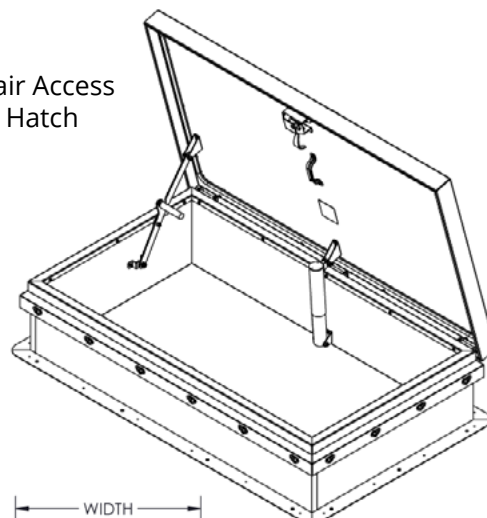

### ADDITIONAL FEATURES:

- |                                   |                                   |  |   |
|-----------------------------------|-----------------------------------|--|---|
| _____ White Textured Finish (WT)  | _____ R-9, 1.5" Polyiso Curb (IP) | _____ Curb Double Wall (CD)                  | _____ Fluoropolymer Finish with 10 Year Warranty (Use Color Code) |
| _____ Gray Textured Finish (GT)   | _____ R-12, 2" Polyiso Curb (IT)  | _____ Curb Heights from 13" to 22" (H13-H22) | _____ Fluoropolymer Finish with 20 Year Warranty (Use Color Code) |
| _____ Red Textured Finish (RT)    | _____ 3/4" Wood Nailer (IW)       | _____ Stainless 316 Hinge Pin (SP)           |   |
| _____ Bronze Textured Finish (BT) | _____ 1" Fiberboard (IF)          | _____ Stainless Hardware (SS)                |   |

### SPECIFICATIONS:

#### Material:

**Curb:** 11 gauge aluminum. Single wall curb and counterflashing with Diamond Grip secure roof membrane without tools.

**Cover:** 11 gauge aluminum. Formed and welded with liner, tested to support a live load of 40psf.

#### Finish:

**Gasket:** Continuous, weatherproof EPDM sponge rubber adhesive-backed seal.

**Insulation:** 1" polyisocyanurate in curb and cover with thermal resistance R-6.

**Hinge:** Heavy duty clear zinc-plated steel pintle hinge.

**Hold Open Arm:** Clear zinc-plated automatic locking hold open arm with red vinyl grip for one handed door operation

**Latch:** Clear zinc-plated steel slam latch with inside and outside handles and padlock hasps. Tested to 50psf wind uplift.

**Spring:** Counterbalanced compression springs contained in clear zinc-plated steel cylinders.

#### Sizes:

**Min Size:** 24" x 24"

**Max Size:** 48" x 72", 36 x 96"

See the Dur-Red RHU Series for larger sizes.

Notes: For pitched roofs up to 7:12, mount hinge side parallel to slope. Door opens 75°.

*Diamond Series™ is a trademark of Activar Construction Products Group, Inc.*

QTY	SIZE W x L	ALUMINUM	TYPE
	36" x 30"	RHDA-1	LADDER
	30" x 54"	RHDA-2	STAIR
	30" x 96"	RHDA-3	STAIR
	36" x 36"	RHDA-4	LADDER
	48" x 48"	RHDA-5	LADDER
	32" x 72"	RHDA-6	STAIR
	37" x 30"	RHDA-7	LADDER
		Custom Size	

*Custom sizes available - enter size above*

It is the responsibility of the customer to communicate specifications and product performance requirements that are needed for their application. This document is intended to convey potential product configurations and offerings. It is not to be used to imply or represent a specification or rating, of finished products shipped. Detailed, specific submittals can be created upon request. It is the responsibility of the customer to specify product accordingly to comply with local laws, codes, and ordinances.



**JL INDUSTRIES**

9702 Newton Avenue S, Bloomington, MN 55431

800-554-6077

sales@activarcpg.com

www.activarcpg.com

Distributor:

Project:

Contractor:

Approved By:

Date:

Architect:

Scale: N/A

Pages: 1 of 1

Item #: