

GENERAL:

Safety railings with compression are designed to compress to the roof hatch curb. The following installation guide suggests recommendations; please install according to local building codes and practices.

TOOLS NEEDED:

- 1/4" and 5/32" Allen Wrenches
- Two (2) 3/4" Wrenches
- Power drill
- T30 Star Bit
- 3/8 Hex Bit

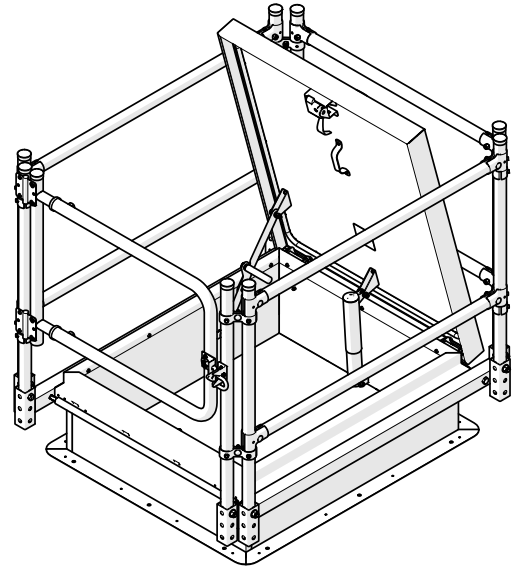

INSTALLATION:

Note: It is preferable to install the safety rail with 2 people

1. Lay the two corner telestrut brackets/compression side mount assembly to the non-gate sides of the roof hatch.
2. Put the one conduit tube on gate side and the other conduit tube on the opposite side. Loosely attach the conduit tubes and compression mount assemblies together with 1/2" - 13 x 4 inch hex bolts on each side. (Fig. 1)
3. Lift up the completed compression mount assembly onto the counterflash of the roof hatch and hand tighten the bolts. (Fig. 2)
4. Install vertical posts into the corner telestrut brackets. Gate mounting posts have pre-drilled holes for gate installation. (Fig. 3)
5. Disassemble telescoping gate into two pieces. Install the hinged piece to the left hand post with the provided 1/4" - 20 x 3/4" Torx screws. (For left hand opening installation see separate left hand gate instructions)
 - a.) Attach the latch catch bracket to the opposite post's pre-drilled holes.
 - b.) Reassemble telescoping gate with hook on outside of gate
 - c.) Adjust telescoping gate to fit exit opening so that latch hook pin properly engages the catch. (Fig. 4) Tighten set screws at that distance to

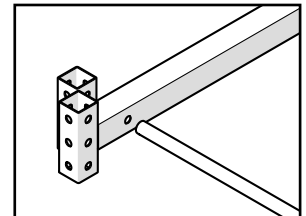

FIG. 1

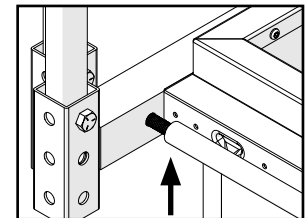

FIG. 2

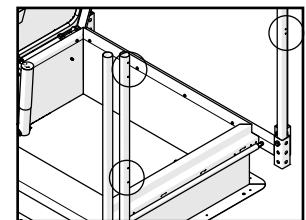

FIG. 3

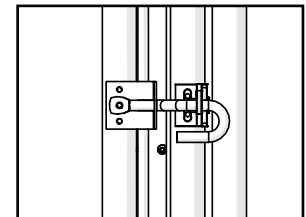

FIG. 4



800-554-6077

sales@activarcpg.com

www.activarcpg.com

9702 Newton Ave S. Bloomington, MN 55431 | Many Locations Nationwide

prevent further telescoping.

6. Install the horizontal rails next. **For OSHA & IBC compliance - top rail must be minimum of 42" off walking surface and no more than 21" between top rail and midrails.** If possible align to match gate rail heights.
 - a.) Attach horizontal rails to vertical posts using two-piece fitting. Once height and level have been checked tighten 3/8"-16 x 1-1/2" center bolt. (Fig. 5)
 - b.) Using 3/8" - 16 x 1-1/2" center bolt, attach clamps on each corner below each railing fitting. Install 3/8" hex head drilling screws into posts and clamp (Fig. 6)
7. Press dome tops onto each vertical post. (Fig. 7)

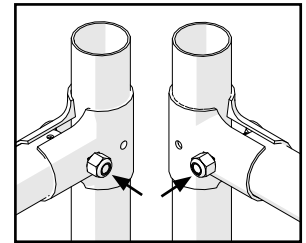

FIG. 5

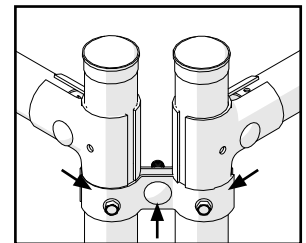

FIG. 6

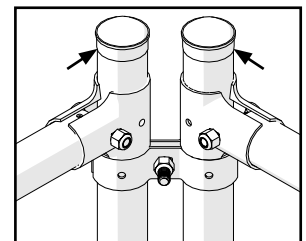

FIG. 7

OPERATION:

Flip up the latch of the gate and pull open the door. (Fig. 8) The gate self-closes due to spring loaded hinges. To test, open the gate 90 degrees and release. If the gate tension needs to be adjusted, use a 5/32" allen wrench at the top of the hinges to tighten or loosen until gate can self-close and latch.

If installing gate to open from other side, part number RSH-KIT-LATCHPINL will be needed. Please contact customer service to order this kit.

MAINTENANCE:

Manually operate once a year to check functionality of moving parts such as latches and hinges. Periodically clean latches and strikes of old grease and dirt using a clean dry cloth. Reapply lubrication as needed. Inspection shall include checking frame alignment, check that all nuts, bolts, and clamps are tight, weight distribution, and improper installation causing damage or failure.

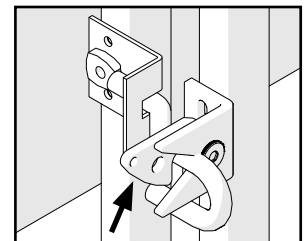

FIG. 8

