

Meets the requirements of **ASTM C 1289, Type II, Class 1, Grade 2 (20 psi)**

- ENRGY 3 / Tapered ENRGY 3

Grade 3 (25 psi)

- ENRGY 3 25 PSI / Tapered ENRGY 3 25 PSI

Features and Components

Glass-Reinforced Facers: Provides rigidity and resistance to indentation and crushing, and are compatible with BUR, modified bitumen and single ply membrane systems.

Closed Cell Polyisocyanurate Foam Core: Provides high R-value per inch in built-up, modified bitumen, metal roof and single ply roof systems, and approved for direct application to steel decks.

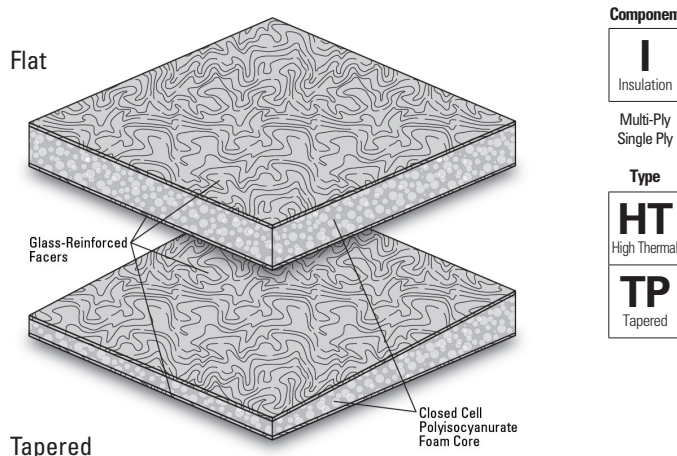

System Compatibility This product may be used as a component in the following systems. Please reference product application for specific installation methods and information.

Multi-Ply	BUR		APP		SBS				
	HA	CA	HW	HA	CA	HW	SA	MF	
Compatible with the selected Multi-Ply systems above									

Single Ply	TPO				PVC			EPDM		
	MF	AD	SA	IW	MF	AD	IW	MF	AD	BA
Compatible with all Single Ply systems										

Key: HA = Hot Applied CA = Cold Applied HW = Heat Weldable SA = Self Adhered MF = Mechanically Fastened IW = Induction Weld BA = Ballasted AD = Adhered

Energy and the Environment

LEED®	Recycled Content	Varies with thickness, see <i>Product Data and Packaging</i> table on next page.
Produced with a pentane blowing agent with zero ozone depletion and virtually no global warming potential.		

Peak Advantage® Guarantee Information

Systems
For use in approved JM Peak Advantage Roofing Guarantees

Codes and Approvals



- FM® Standards 4450/4470 Approvals (refer to FM RoofNavSM)
- UL® Standard 790, 263 and 1256 (refer to UL Roofing Materials system directory)
- Meets the requirements of CAN/ULC 704, Type 2 & 3, Class 3
- California Code of Regulations, Title 24, Insulation Quality Standard License #TI-1341
- Third-party certification with the PIMA Quality Mark™ for Long-Term Thermal Resistance (LTR) values

Technical specifications as shown in this literature are intended to be used as general guidelines only. Please refer to the Safety Data Sheet and product label prior to using this product. The Safety Data Sheet is available by calling (800) 922-5922 or on the web at www.jm.com/roofing. The physical and chemical properties of the product listed herein represent typical, average values obtained in accordance with accepted test methods and are subject to normal manufacturing variations. They are supplied as a technical service and are subject to change without notice. Check with the regional sales representative nearest you for current information.

Installation/Application



Refer to the application instructions guidelines for proper utilization of this product.

Flute Span:			
Width of Rib Opening:	Up to 2 ⁵ / ₈ " (6.67 cm)	Up to 3 ³ / ₈ " (8.57 cm)	Up to 4 ³ / ₈ " (11.11 cm)
Insulation Thickness (min):	1.0" (2.54 cm)	1.2" (3.05 cm)	≥1.3" (3.30 cm)

Packaging and Dimensions

Flat Sizes¹	4' x 4' (1.22 m x 1.22 m)	4' x 8' (1.22 m x 2.44 m)	
Tapered Size²	4' x 4' (1.22 m x 1.22 m)		
Producing Locations	Bremen, IN Hazleton, PA	Cornwall, ONT Jacksonville, FL	Fernley, NV Hillsboro, TX

1. For available thicknesses, see *Product Data and Packaging* table on page 2 of this data sheet. Other sizes available by special request, some sizes are not stocked but can be special ordered with minimum order quantities. Contact your JM Sales Representative for details.
2. Tapered ENRGY 3 and Tapered ENRGY 3 25 PSI are available in thicknesses of 1/2" to 4". Available profiles are shown on page 3 of this data sheet. In some regions extended panels are also available.

Storage

For storage less than two weeks, the packaging is adequate for outside storage without tarps provided the insulation arrives intact with the original undamaged weather-tight plastic bag. For storage greater than two weeks, JM recommends slitting the plastic shrink bag prior to covering the pallet with a breathable tarpaulin, to allow for venting.

For storage greater than one month, insulation should be stored indoors in a dry, well-ventilated warehouse. JM insulation should not be stored in or around standing water and should not be left exposed to weather. No more insulation should be installed than can be completely covered with membrane on the same day. Always install boards with printed side down as labeled on each board.

Typical Physical Properties

Test		ASTM	Values
Strength	Tensile Strength	C 209	500 psf (24 kPa) (<i>min</i>), 730 psf (35 kPa) (<i>nom</i>)
	Compressive Resistance 10% Consolidation	D 1621	Grade 2: 20 psi (138 kPa), Grade 3: 25 psi (172 kPa) (<i>min</i>)
	Dimensional Stability Change, (<i>length & width</i>)	D 2126	0.5% (<i>nom</i>), 2% (<i>max</i>)
Moisture	Moisture Vapor Permeance	E 96	<1 perm, 57.5 ng/(Pa•s•m ²)
	Water Absorption	C 209	1.0% (<i>max</i>)
Insulation	Service Temperature	D 1623	-100°F – 250°F (-73°C – 121°C)
	Flame Spread, (<i>foam core</i>)	E 84	20 - 30 (<i>nom</i>), 75 (<i>max</i>)
	Smoke Developed, (<i>foam core</i>)	E 84	55 - 250 (<i>nom</i>), 450 (<i>max</i>)

Product Data and Packaging

Thickness		Long-Term Thermal Resistance (LTTR) Values ¹		Recycled Content ²			Boards per Pallet	Square Feet per Pallet		Pallets per Truck ³	
in.	mm	(hr•ft ² •°F)/BTU	m ² •°C/W	% Pre-Consumer	% Post-Consumer	% Total	4x4 and 4x8	4x4	4x8	4x4	4x8
1.0	25.4	5.7	1.00	9.8%	32.3%	42.2%	48	768	1536	48	24
1.1	27.9	6.3	1.10	10.2%	30.4%	40.6%	41	656	1312		
1.2	30.5	6.8	1.20	10.5%	28.6%	39.2%	38	608	1216		
1.25	31.8	7.1	1.25	10.7%	27.8%	38.5%	35	560	1120		
1.3	33.0	7.4	1.30	10.8%	27.1%	37.9%	35	560	1120		
1.4	35.6	8.0	1.41	11.1%	25.7%	36.8%	32	512	1024		
1.5	38.1	8.6	1.51	11.3%	24.4%	35.7%	32	512	1024		
1.6	40.6	9.1	1.61	11.5%	23.3%	34.8%	28	448	896		
1.7	43.2	9.7	1.71	11.7%	22.3%	34.0%	27	432	864		
1.75	44.5	10.0	1.76	11.8%	21.8%	33.6%	27	432	864		
1.8	45.7	10.3	1.81	11.9%	21.3%	33.2%	25	400	800		
1.9	48.3	10.8	1.91	12.1%	20.4%	32.5%	24	384	768		
2.0	50.8	11.4	2.01	12.2%	19.6%	31.8%	24	384	768		
2.1	53.3	12.0	2.11	12.3%	18.9%	31.2%	21	336	672		
2.2	55.9	12.6	2.22	12.5%	18.2%	30.7%	21	336	672		
2.3	58.4	13.2	2.32	12.6%	17.6%	30.2%	20	320	640		
2.4	61.0	13.8	2.43	12.7%	17.0%	29.7%	19	304	608		
2.5	63.5	14.4	2.53	12.8%	16.4%	29.2%	19	304	608		
2.6	66.0	15.0	2.64	12.9%	15.9%	28.8%	18	288	576		
2.7	68.6	15.6	2.74	13.0%	15.4%	28.4%	17	272	544		
2.8	71.1	16.2	2.85	13.1%	14.9%	28.0%	16	256	512		
2.9	73.7	16.8	2.96	13.2%	14.5%	27.7%	16	256	512		
3.0	76.2	17.4	3.06	13.2%	14.1%	27.3%	16	256	512		
3.1	78.7	18.0	3.17	13.3%	13.7%	27.0%	14	224	448		
3.2	81.3	18.6	3.28	13.4%	13.3%	26.7%	14	224	448		
3.25	82.6	18.9	3.33	13.4%	13.2%	26.6%	14	224	448		
3.3	83.8	19.2	3.39	13.4%	13.0%	26.4%	14	224	448		
3.4	86.4	19.9	3.50	13.5%	12.7%	26.2%	13	208	416		
3.5	88.9	20.5	3.61	13.6%	12.4%	25.9%	13	208	416		
3.6	91.4	21.1	3.72	13.6%	12.1%	25.7%	12	192	384		
3.7	94.0	21.7	3.82	13.7%	11.8%	25.5%	12	192	384		
3.75	95.3	22.0	3.88	13.7%	11.6%	25.3%	12	192	384		
3.8	96.5	22.3	3.94	13.7%	11.5%	25.2%	12	192	384		
3.9	99.1	23.0	4.05	13.8%	11.2%	25.0%	12	192	384		
4.0	101.6	23.6	4.16	13.8%	11.0%	24.8%	12	192	384		
4.1	104.0	24.2	4.26	13.9%	10.8%	24.6%	11	176	352		
4.2	107.0	24.9	4.39	13.9%	10.5%	24.4%	11	176	352		
4.3	109.0	25.5	4.49	13.9%	10.3%	24.3%	11	176	352		
4.4	112.0	26.1	4.60	14.0%	10.1%	24.1%	10	160	320		
4.5	114.0	26.8	4.72	14.0%	9.9%	23.9%	10	160	320		

1. The Long-Term Thermal Resistance (LTTR) values were determined in accordance with CAN/ULC S770 at 75°F (24°C). The ultimate R-Value of these products will depend on individual installation circumstances.

2. Value represents average results (Grade 2/Grade 3). 3. Assumes 48' flatbed truck.

JM Minimum Required Pre-securement Pattern when used with a Mechanically Fastened Membrane. For boards with Glass-Reinforced Facer, thickness 1" or less.

4' x 4' BOARDS

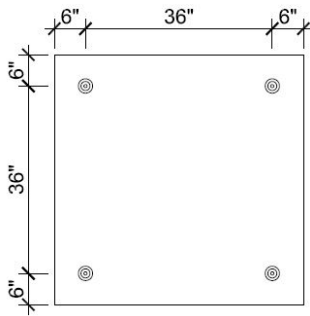

4' x 8' BOARDS

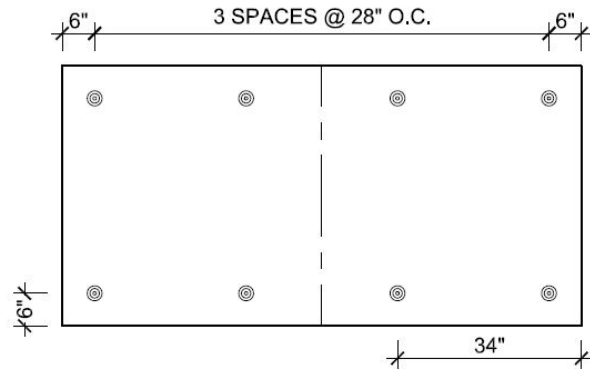

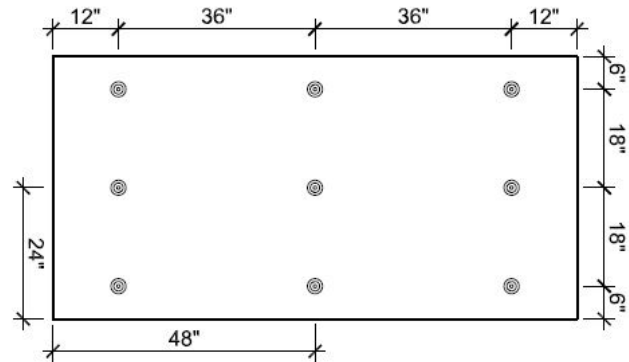

8-Fastener pre-securement pattern does not apply to RhinoBond applications.

JM Minimum Required Fastening Pattern when used with JM RhinoPlate Fastening System

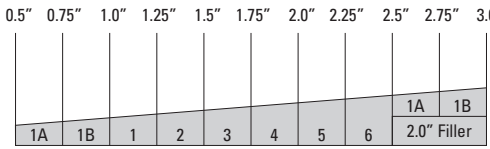
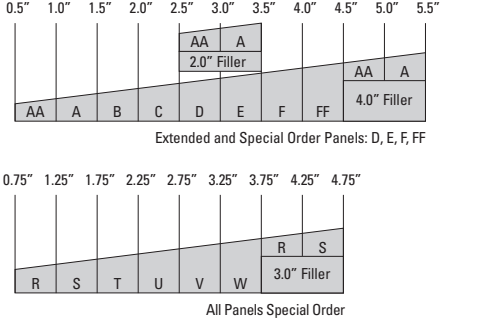

Minimum field attachment pattern. Contact your Technical Specialist for membrane fastener requirements.

Johns Manville Tapered Polyiso Offerings *Please refer to the previous page for typical physical properties.*

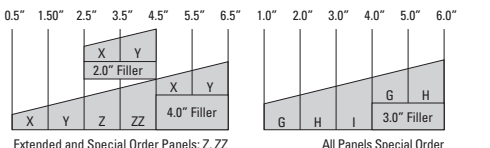
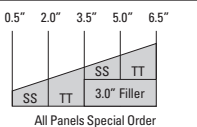
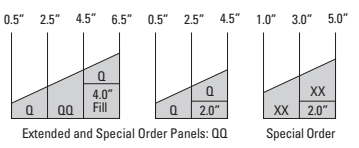
Panel Desig.	Slope	Dimension		LTTR* Value Nominal	Pieces per Unit	Square Foot per Unit	Brd Ft per Unit	Slope Profiles	
		Thin	Thick						
1/16 in/ft (5.2 mm/m)									
1A	1/16	0.5	0.75	3.6	70	1120	700	 <p>0.5" 0.75" 1.0" 1.25" 1.5" 1.75" 2.0" 2.25" 2.5" 2.75" 3.0"</p> <p>All Panels Special Order</p>	
1B	1/16	0.75	1	5.0	50	800	700		
1	1/16	1	1.25	6.4	38	608	684		
2	1/16	1.25	1.5	7.8	32	512	704		
3	1/16	1.5	1.75	9.3	28	448	728		
4	1/16	1.75	2	10.7	22	352	660		
5	1/16	2	2.25	12.1	20	320	680		
6	1/16	2.25	2.5	13.6	18	288	684		
1/8 in/ft (10.4 mm/m)									
AA	1/8	0.5	1	4.3	64	1024	768	 <p>0.5" 1.0" 1.5" 2.0" 2.5" 3.0" 3.5" 4.0" 4.5" 5.0" 5.5"</p> <p>Extended and Special Order Panels: D, E, F, FF</p> <p>All Panels Special Order</p>	
A	1/8	1	1.5	7.1	38	608	760		
B	1/8	1.5	2	10.0	26	416	728		
C	1/8	2	2.5	12.9	20	320	720		
D**	1/8	2.5	3	15.9	16	256	704		
E**	1/8	3	3.5	18.9	14	224	728		
F**	1/8	3.5	4	22.1	12	192	720		
FF**	1/8	4	4.5	25.3	10	160	680		
R	1/8	0.75	1.25	5.7	44	704	704		
S	1/8	1.25	1.75	8.6	30	480	720		
T	1/8	1.75	2.25	11.4	22	352	704		
U	1/8	2.25	2.75	14.4	16	256	640		
V	1/8	2.75	3.25	17.4	14	224	672		
W	1/8	3.25	3.75	20.5	12	192	672		
3/16 in/ft (15.6 mm/m)									
J	3/16	1	1.75	7.8	32	512	704		 <p>1.0" 1.75" 2.5" 3.25" 4.0" 4.75" 5.5" 0.5" 1.25" 2.0" 2.75" 3.5" 4.25" 5.0"</p> <p>All Panels Special Order</p>
K	3/16	1.75	2.5	12.1	20	320	680		
L**	3/16	2.5	3.25	16.6	16	256	736		
M**	3/16	3.25	4	21.2	12	192	696		
JJ	3/16	0.5	1.25	5.0	52	832	728		
KK	3/16	1.25	2	9.3	28	448	728		
LL**	3/16	2	2.75	13.6	18	288	691		
MM**	3/16	2.75	3.5	18.2	14	224	694		
1/4 in/ft (20.8 mm/m)									
G	1/4	1	2	8.6	32	512	768	 <p>0.5" 1.50" 2.5" 3.5" 4.5" 5.5" 6.5" 1.0" 2.0" 3.0" 4.0" 5.0" 6.0"</p> <p>Extended and Special Order Panels: Z, ZZ</p> <p>All Panels Special Order</p>	
H	1/4	2	3	14.4	18	288	720		
I**	1/4	3	4	20.5	12	192	672		
X	1/4	0.5	1.5	5.7	48	768	768		
Y	1/4	1.5	2.5	11.4	24	384	768		
Z**	1/4	2.5	3.5	17.4	16	256	768		
ZZ**	1/4	3.5	4.5	23.6	12	192	768		
3/8 in/ft (31.2 mm/m)									
SS	3/8	0.5	2	7.1	36	576	720	 <p>0.5" 2.0" 3.5" 5.0" 6.5"</p> <p>All Panels Special Order</p>	
TT**	3/8	2	3.5	15.9	16	256	704		
1/2 in/ft (41.6 mm/m)									
Q	1/2	0.5	2.5	8.6	32	512	768	 <p>0.5" 2.5" 4.5" 6.5" 0.5" 2.5" 4.5" 1.0" 3.0" 5.0"</p> <p>Extended and Special Order Panels: QQ</p> <p>Special Order</p>	
QQ**	1/2	2.5	4.5	20.5	12	192	672		
XX	1/2	1	3	11.4	22	352	704		

* (hr•ft²•°F/Btu)

** Extended panels require less adhesive and less labor.

Tapered Recycle Content:

Recycled content is dependent upon average thickness. To calculate, match the average thickness of Tapered ENRGY 3 to the thickness of Flat ENRGY 3. Use the number from Flat ENRGY 3 as your recycled content.

All Johns Manville products are sold subject to Johns Manville's standard Terms and Conditions, which includes a Limited Warranty and Limitation of Remedy. For a copy of the Johns Manville standard Terms and Conditions or for information on other Johns Manville roofing products and systems, visit www.jm.com/terms-conditions.