

Features and Components

The JM Purlin Fastener is designed for attaching single-ply membrane systems to 12 - 18 gauge (2.8 - 1.25 mm) structural steel purlins in standing seam metal roof retrofit application.

The JM Purlin Fastener has a 3/4" (20 mm) drill point which allows the screw to quickly drill through the purlin before the treads engage into the standing seam metal roof.

- Use:** Membranes
- Material:** CR-10 Coated Steel
- Gauge:** #12
- Head:** 1/4" Hex Head
- Plate:** Compatible JM High Load Plate
- Color:** Grey
- Deck Type:** Structural Steel Purlins 12 - 18 gauge (2.77 mm - 1.25 mm) Metal.

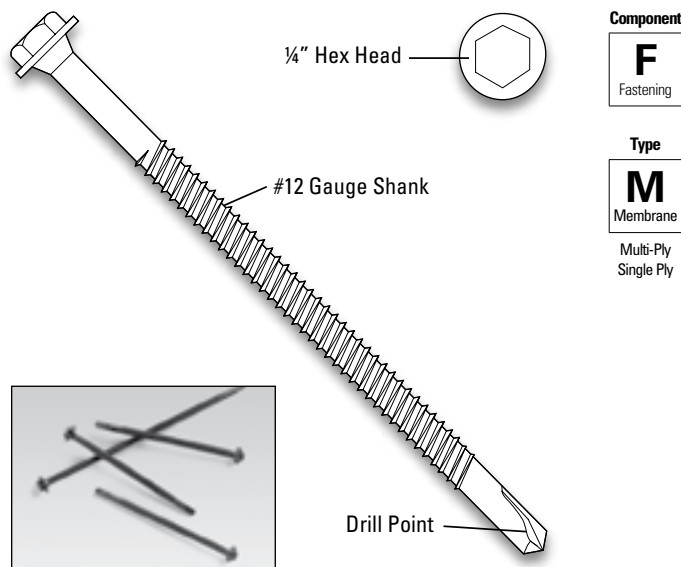

System Compatibility This product may be used as a component in the following systems. Please reference product application for specific installation methods and information.

| | | | | | | | | |
|-----------|-----|-----|----|-----|----|----|----|----|
| Multi-Ply | BUR | APP | | SBS | | | | |
| | HA | CA | HW | HA | CA | HW | SA | MF |

Compatible with the selected multi-ply systems above

| | | | | | | | | | |
|------------|-----|----|----|----|-----|----|----|------|----|
| Single Ply | TPO | | | | PVC | | | EPDM | |
| | MF | AD | SA | IW | MF | AD | IW | MF | AD |

Do not use in single ply systems

Key: HA = Hot Applied CA = Cold Applied HW = Heat Weldable SA = Self Adhered MF = Mechanically Fastened IW = Induction Weld BA = Ballasted AD = Adhered

Energy and the Environment

| | |
|------------------|---|
| Recycled Content | This steel based product contains a minimum of 25% post consumer recycled materials by weight |
|------------------|---|

Peak Advantage® Guarantee Information

| |
|---|
| Systems |
| Approved to use with any Peak Advantage Guarantee |

Codes and Approvals*



*Fastener approvals are based on system approvals

Technical specifications as shown in this literature are intended to be used as general guidelines only. Please refer to the Safety Data Sheet and product label prior to using this product. The Safety Data Sheet is available by calling (800) 922-5922 or on the web at www.jm.com/roofing. The physical and chemical properties of the product listed herein represent typical, average values obtained in accordance with accepted test methods and are subject to normal manufacturing variations. They are supplied as a technical service and are subject to change without notice. Check with the regional sales representative nearest you for current information.

All Johns Manville products are sold subject to Johns Manville's standard Terms and Conditions, which includes a Limited Warranty and Limitation of Remedy. For a copy of the Johns Manville standard Terms and Conditions or for information on other Johns Manville roofing products and systems, visit www.jm.com/terms-conditions.

Installation/Application

The JM Purlin Fastener must penetrate the purlin a minimum of 1-in. This ensures a minimum of 1/4-in. thread penetration into the structural member. Using a screw gun with a maximum of 1800 RPM, drive the fastener through the purlin until a slight depression is seen around the plate.

Note: Caution should be taken not to overdrive the fastener causing stress plate surface to deflect more than 1/16-in.

Packaging and Dimensions

| Fastener Sizes | Quantity per Container |
|--|---------------------------|
| 3 3/4" (95.3 mm), 4 3/4" (120.7 mm), 5 3/4" (146.1 mm), 7" (177.8 mm), 8" (203.2 mm) | 500/pail |
| Producing Locations* | Agawam, MA and Itasca, IL |

* The point of manufacture for fasteners and plates varies depending on the specific part. Call your local JM sales professional for assistance.



JM PURLIN FASTENER

Roof Membrane Fastener

Product Specifications

| Product Description | Part Length | | Shank Length | | Thread Length | |
|-----------------------|-------------|-------|--------------|-------|---------------|------|
| | (inches) | (mm) | (inches) | (mm) | (inches) | (mm) |
| PURLIN 3 3/4" 500/BOX | 3 3/4 | 95.3 | 0 | 0 | FULL | FULL |
| PURLIN 4 3/4" 500/BOX | 4 3/4 | 120.7 | 1 3/4 | 44.5 | 3 | 76.2 |
| PURLIN 5 3/4" 500/BOX | 5 3/4 | 146.1 | 2 3/4 | 69.9 | 3 | 76.2 |
| PURLIN 7" 500/BOX | 7 | 177.8 | 4 | 101.6 | 3 | 76.2 |
| PURLIN 8" 500/BOX | 8 | 203.2 | 5 | 127 | 3 | 76.2 |