

1) Remove any irregularities in the existing concrete by grinding or scabbling. Thoroughly clean concrete surface using:

- a. Wire Brush
- b. Needle Gun
- c. Abrasive Blast
- d. Acid Wash
- e. High Pressure Water Blast
- f. Or any combination of the above to ensure surface to receive epoxy is clean.

2) Establish the finish grade line and drill fastener pilot holes into the concrete using batten bar as a template. Pilot holes should be drilled through every batten bar hole. Perform a "dry fit" with all waterstop components to ensure all pieces are welded and fit properly.

3) Ensure surface is clean and dry, then apply an epoxy strip 1/8" (3 mm) by 3" (75 mm) on the concrete surface (from the top of the grade line down). (See VEN500/VEN1000 Data Sheet for epoxy mixing instructions and pot life at different temperatures.)

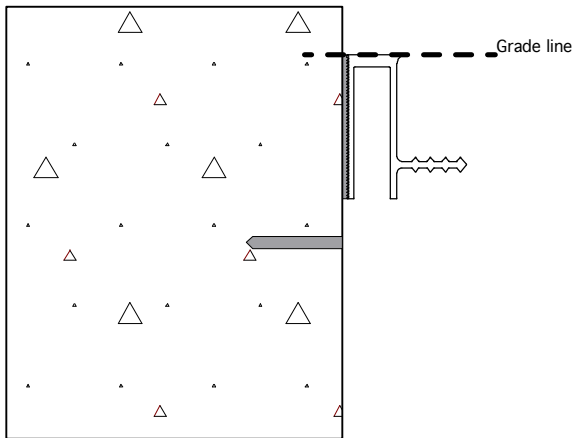

4) Embed prefabricated retrofit waterstop into strip of uncured epoxy.

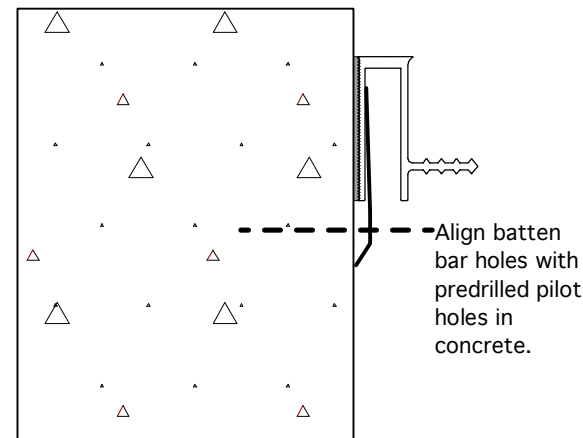

5) Ensure retrofit waterstop is located at the proper grade and position batten bar.

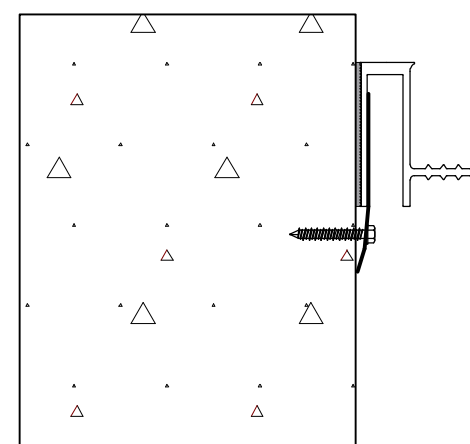

6) Install fasteners through washer, batten bar and into the predrilled pilot holes in the concrete. Tighten fasteners using CONDRIVE® 1000 by ITW Ramset/Red Head until completely seated. (Clutch mechanism in CONDRIVE protects the Tapcon anchor from over-tightening. The stainless steel batten bar will compress as fastener is tightened.)

7) Allow installed system to cure 24 hours before placing concrete.

JPEB375R Retrofit Installation

Scale: 3" = 1'-0"

1