



CERTIFICATION



Approved. Sealed. Code Compliant.

Technical Evaluation Report

TER 1410-09

Attachment of Exterior Wall Coverings
Through Kingspan® GreenGuard®
Extruded Polystyrene (XPS) Sheathing
to Wood or Steel Wall Framing

Kingspan® Insulation LLC

Product:

**Kingspan® GreenGuard®
Insulation Boards**

Issue Date:

January 30, 2015

Revision Date:

September 18, 2019

Subject to Renewal:

October 1, 2020



For the most recent version or a sealed copy of this Technical Evaluation Report (TER), visit drjcertification.org.

COMPANY
INFORMATION:

Kingspan® Insulation LLC

2100 RiverEdge Parkway
Suite 175
Atlanta, GA 30328

kingspan.com/us/en-us

DIVISION: 07 00 00 - THERMAL AND MOISTURE PROTECTION

SECTION: 07 21 00 - Thermal Insulation

SECTION: 07 40 00 - Roofing and Siding Panels

SECTION: 07 46 00 - Siding

1 PRODUCT EVALUATED¹

1.1 Kingspan® GreenGuard® Insulation Boards

- 1.1.1 Kingspan® GreenGuard® CM
- 1.1.2 Kingspan® GreenGuard® SL
- 1.1.3 Kingspan® GreenGuard® SLX
- 1.1.4 PGU – GreenGuard® PLYGOOD Sheathing Products

2 APPLICABLE CODES AND STANDARDS^{2,3}

2.1 Codes

- 2.1.1 *IBC—12, 15, 18: International Building Code®*
- 2.1.2 *IECC— 12, 15, 18: International Energy Conservation Code*
- 2.1.3 *IRC—12, 15, 18: International Residential Code®*

2.2 Standards and Referenced Documents

- 2.2.1 *AISI S100: North American Specification for the Design of Cold-formed Steel Structural Members*
- 2.2.2 *ANSI/AWC NDS: National Design Specification (NDS) for Wood Construction*

¹ Building codes require data from valid research reports be obtained from approved sources. An approved agency, which is an approved source, is defined as “an established and recognized agency that is regularly engaged in...furnishing product certification where such agency has been approved...” Being approved, defined as “acceptable to the building official,” is accomplished via accreditation using ISO/IEC 17065 evaluation procedures meeting code requirements of independence, adequate equipment, and experienced personnel. DrJ is an ISO/IEC 17065 ANSI-Accredited Product Certification Body – Accreditation #1131.

Through ANSI accreditation, DrJ certification can be used to obtain product approval in any country that is an IAF MLA Signatory and covered by an IAF MLA Evaluation per the Purpose of the MLA – “certified once, accepted everywhere.” Manufacturers can go to jurisdictions in any IAF MLA Signatory Country and have their products readily approved by authorities having jurisdiction using DrJ’s ANSI accreditation.

For more information on any of these topics or our mission, product evaluation policies, product approval process, and engineering law, see drjcertification.org.

² Unless otherwise noted, all references in this TER are from the 2018 version of the codes and the standards referenced therein (e.g., *ASCE 7*, *NDS*, *ASTM*). This material, design, or method of construction also complies with the 2000-2015 versions of the referenced codes and the standards referenced therein. As required by code, where this TER is not approved, the building official shall respond in writing stating the reasons this TER was not approved. For any variations in state and local codes, see Section 8.

³ All terms defined in the applicable building codes are italicized.

- 2.2.3 *ASCE/SEI 7: Minimum Design Loads and Associated Criteria for Buildings and Other Structures*
- 2.2.4 *ASTM C1063: Standard Specification for Installation of Lathing and Furring to Receive Interior and Exterior Portland Cement-Based Plaster*
- 2.2.5 *ASTM C1513: Standard Specification for Steel Tapping Screws for Cold-Formed Steel Framing Connections*
- 2.2.6 *ASTM C578: Standard Specification for Rigid, Cellular Polystyrene Thermal Insulation*
- 2.2.7 *ASTM C847: Standard Specification for Metal Lath*
- 2.2.8 *ASTM F1667: Standard Specification for Driven Fasteners: Nails, Spikes, and Staples*
- 2.2.9 *SBCA ANSI/FS 100: Standard Requirements for Wind Pressure Resistance of Foam Plastic Insulating Sheathing Used in Exterior Wall Covering Assemblies*

3 PERFORMANCE EVALUATION

- 3.1 This TER examines the attachment of exterior wall coverings through Kingspan® GreenGuard® Extruded Polystyrene (XPS) Insulation Boards, with thickness up to 3", to wood or cold-formed steel wall studs.
- 3.2 This TER also provides a step-by-step approach for the design process of attaching exterior wall coverings through XPS to wood or steel wall framing.
- 3.3 This evaluation and design methodology considers only the weight of the exterior covering on fasteners cantilevered through the XPS and into the stud.
- 3.4 Wind pressure resistance of the exterior covering is outside the scope of this TER. Consult the exterior covering manufacturer's installation instructions for information regarding the allowable design wind pressure for a given product, in accordance with *SBCA ANSI/FS 100*.
 - 3.4.1 The intent of this TER is not to reduce minimum fastener sizes, penetrations and spacings required to resist wind loads. Where fastener requirements for wind resistance or cladding weight are more stringent, they shall control the design.
- 3.5 Attachment of window flanges over XPS is outside the scope of this TER.
- 3.6 Any code compliance issues not specifically addressed in this section are outside the scope of this TER.
- 3.7 Any engineering evaluation conducted for this TER was performed on the dates provided in this TER and within Dr.J's professional scope of work.

4 PRODUCT DESCRIPTION AND MATERIALS

- 4.1 GreenGuard® Insulation Boards shall comply with the following material standards:
 - 4.1.1 XPS manufactured in compliance with *ASTM C578*
- 4.2 GreenGuard® Insulation Boards shall have a minimum compressive strength of 25 psi.
- 4.3 Where wind pressure resistance is required, GreenGuard® Insulation Boards shall comply with *SBCA ANSI/FS 100*.
- 4.4 Kingspan® GreenGuard® Insulation Boards are proprietary foam plastic insulating sheathing (FPIS) made from extruded polystyrene in accordance with *ASTM C578, Type IV*.
- 4.5 Kingspan® GreenGuard® Insulation Boards are available with various edge treatments and facers as follows:
 - 4.5.1 GreenGuard® CM – square edges
 - 4.5.2 GreenGuard® SL – shiplap edges
 - 4.5.3 GreenGuard® SLX – film facer on both sides, shiplap edges
 - 4.5.4 PGU – GreenGuard® PLYGOOD Sheathing Products – film facers with or without reinforcing polyolefin fabric

4.6 *Material Availability*

- 4.6.1 Thickness: 1/4" (32 mm) through 3" (76 mm)
- 4.6.2 Standard product width: 48" (1219 mm)
- 4.6.3 Standard product length: 96" (2438 mm) and 108" (2743 mm)
- 4.7 Consult the manufacturer for the availability of a given product with non-standard width or length.

5 APPLICATIONS

5.1 *Structural Applications*

5.1.1 Where the application exceeds the limitations set forth herein, design shall be permitted in accordance with accepted engineering procedures, experience, and technical judgment.

5.2 *Design Procedure*

5.2.1 Determine an appropriate cladding attachment requirement in accordance with Section 5.2 through 5.4.

5.3 Select one of the following methods of cladding attachment:

- 5.3.1 Direct attachment of cladding through GreenGuard® Insulation Boards to wall framing, Figure 1.
- 5.3.2 Furring attachment through GreenGuard® Insulation Boards to wall framing, Figure 2, whereby cladding is attached to furring in accordance with the applicable building code and the cladding manufacturer's installation instructions.

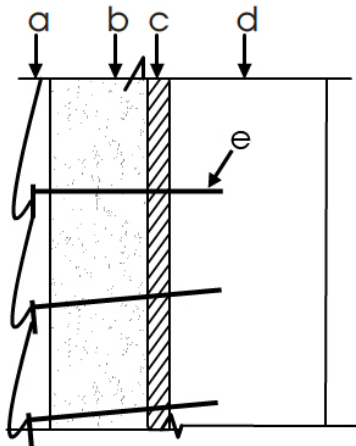

Exterior Wall Covering Assembly (direct attachment):

- a – Cladding material and fasteners
- b – Thickness of GreenGuard® Insulation Boards, as required
- c – Optional wall sheathing or as required by the applicable building code (e.g., gypsum sheathing, WSP or other)⁴
- d – Wall framing per code (i.e., wood or cold-formed steel studs)
- e – Fastener per **Table 1** or by design

FIGURE 1. ILLUSTRATION OF EXTERIOR WALL COVERING ASSEMBLY COMPONENTS (DIRECT ATTACHMENT), NOTE: WALL SHEATHING LAYER "C" IS OPTIONAL, UNLESS REQUIRED BY THE APPLICABLE BUILDING CODE

⁴ For compliance with the 2015 and 2018 IRC and IBC, where a separate structural sheathing layer is not provided to separately resist wind load, the FPIS must comply with SBCA ANSI/FS 100.

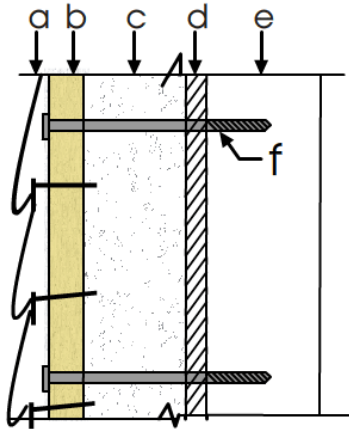

Exterior Wall Covering Assembly (through furring):

- a – Cladding material and fasteners
- b – Min 3/4"-thick (nominal 1x3 or larger) wood furring or min. 3/4" plywood (Exterior 1)⁵
- c – Thickness of GreenGuard® Insulation Boards, as required
- d – Optional wall sheathing or as required by the applicable building code (e.g., gypsum sheathing, WSP or other)⁶
- e – Wall framing per code (i.e., wood or cold-formed steel studs)
- f – Fastener per Table 2 or by design

FIGURE 2. ILLUSTRATION OF EXTERIOR WALL COVERING ASSEMBLY COMPONENTS (THROUGH FURRING)
NOTE: WALL SHEATHING LAYER "D" IS OPTIONAL, UNLESS REQUIRED BY THE APPLICABLE BUILDING CODE

- 5.4 From Table 1 for "direct attachment" method or Table 2 for "furring attachment" method, determine the maximum allowable GreenGuard® Insulation Board thickness based on a selected minimum fastener size, maximum fastener spacing, and the cladding system weight.
 - 5.4.1 To determine cladding system weight, add the weight of all materials on the exterior side of the foam sheathing (see 'a' in Figure 1 and 'a' and 'b' in Figure 2).
 - 5.4.2 Use actual weights for the materials installed. Actual cladding weights of materials can be obtained from the cladding manufacturer's material specifications. Other typical weights of building materials can be found in the Commentary to ASCE 7-10.

⁵ Siding fastening into a suitable nail-base sheathing shall be permitted for claddings not weighing more than 3 psf and foam sheathing thicknesses not greater than 2"; refer to [2018 IRC Section R703](#) for requirements.

⁶ Minimum required furring thickness may increase where cladding fastening requirements dictate more penetration depth in framing; alternatively, a compatible siding fastener with adequate withdrawal resistance shall be specified.

TABLE 1. SIDING MINIMUM FASTENING REQUIREMENTS FOR DIRECT CLADDING ATTACHMENT

Cladding Fastener Through GreenGuard® Insulation Boards into:	Siding Fastener – Type & Minimum Size	Siding Fastener Vertical Spacing (in)	Maximum Thickness of GreenGuard® Insulation Boards (in)							
			16" o.c. Fastener Horizontal Spacing				24" o.c. Fastener Horizontal Spacing			
			Max. Cladding Weight:				Max. Cladding Weight:			
			3 psf	11 psf	18 psf	25 psf	3 psf	11 psf	18 psf	25 psf
Wood Framing (minimum 1 1/4" penetration)	0.113" diameter nail	6	2	1.45	0.75	DR	2	0.85	DR	DR
		8	2	1	DR	DR	2	0.55	DR	DR
		12	2	0.55	DR	DR	1.85	DR	DR	DR
	0.120" diameter nail	6	3	1.70	0.90	0.55	3	1.05	0.50	DR
		8	3	1.20	0.60	DR	3	0.70	DR	DR
		12	3	0.70	DR	DR	2.15	DR	DR	DR
	0.131" diameter nail	6	4	2.15	1.20	0.75	4	1.35	0.70	DR
		8	4	1.55	0.80	DR	4	0.90	DR	DR
		12	4	0.90	DR	DR	2.70	0.50	DR	DR
	0.162" diameter nail	6	4	3.55	2.05	1.40	4	2.25	1.25	0.80
		8	4	2.55	1.45	0.95	4	1.60	0.85	0.50
		12	4	1.60	0.85	0.50	4	0.95	DR	DR
Steel Framing (minimum penetration of steel thickness + 3 threads)	#8 screw into 33 mil steel or thicker	6	3	2.95	2.20	1.45	3	2.35	1.25	DR
		8	3	2.55	1.60	0.60	3	1.80	DR	DR
		12	3	1.80	DR	DR	3	0.65	DR	DR
	#10 screw into 33 mil steel	6	4	3.50	2.70	1.95	4	2.90	1.70	0.55
		8	4	3.10	2.05	1	4	2.25	0.70	DR
		12	4	2.25	0.70	DR	3.70	1.05	DR	DR
	#10 screw into 43 mil steel or thicker	6	4	4	4	3.60	4	4	3.45	2.70
		8	4	4	3.70	3	4	3.85	2.80	1.80
		12	4	3.85	2.80	1.80	4	3.05	1.50	DR

SI: 1 in = 25.4 mm; 1 pound per square foot [psf] = 0.0479 kPa

1. Tabulated requirements are based on wood framing of Spruce-Pine-Fir or any wood species with a specific gravity of 0.42 or greater in accordance with AFPA/NDS and minimum 33 ksi steel for 33 mil and 43 mil steel and 50 ksi steel for 54 mil steel or thicker.
2. Cladding weight shall include all materials supported by the fasteners on the exterior side of the GreenGuard® Insulation Board (e.g., wood structural panel sheathing may be installed between the cladding material and the GreenGuard® Insulation Board). In such cases, both the cladding and the WSP sheathing weight must be included in the calculation for the cladding weight.
3. Examples of cladding included in each weight category: 3 psf – vinyl siding, 11 psf – fiber cement siding, 25 psf – masonry or cultured stone. Examples are not inclusive.
4. Nail fasteners shall comply with ASTM F1667, except nail length shall be permitted to exceed ASTM F1667 standard lengths. Screws shall comply with ASTM C1513.
5. Self-drilling tapping screw fasteners for connection of siding to steel framing shall comply with the requirements of AISI S200. Other approved fasteners of equivalent or greater diameter and bending strength shall be permitted.
6. For cladding system weights exceeding 25 psf with any thickness of GreenGuard® Insulation Boards, a design professional should be consulted.
7. Max. foam thickness of 2" for 0.113" and 0.120" diameter nails for 3 psf cladding weight due to limiting factor of nail length.
8. GreenGuard® Insulation Board shall have a minimum compressive strength of 15 psi in accordance with ASTM C578.
9. Metal lath shall be minimum 2.5 lbs./yd.² diamond mesh in accordance with ASTM C847. Metal lath lock washers on fasteners are highly recommended.
10. Vertical spacing of fasteners in metal lath shall not exceed 7" o.c., in accordance with ASTM C1063 and the Masonry Veneer Manufacturers Association (MVMA) Installation Guide.
11. Where adhered masonry is used, it shall be installed in accordance with the MVMA Installation Guide.
12. Linear interpolation between cladding weight categories is not permitted.
13. DR = Design Required



TABLE 2. FURRING MINIMUM FASTENING REQUIREMENTS FOR APPLICATION OVER FOAM PLASTIC INSULATING SHEATHING

Furring Material	Framing Member	Fastener Type & Min. Size	Min. Penetration into Wall Framing (in)	Fastener Spacing in Furring (in)	Max. Thickness of GreenGuard® Insulation Board (in)								Allowable Wind Pressure Resistance of Furring Attachment (psf)	
					16" o.c. Furring				24" o.c. Furring					
					Siding Weight:				Siding Weight:				16" o.c.	24" o.c.
					3 psf	11 psf	18 psf	25 psf	3 psf	11 psf	18 psf	25 psf		
Min. 1x3 Wood Furring	Min. 2x Wood Stud	Nail (0.120" shank; 0.271" head)	1 1/4	8	2	1.85	1.05	0.65	2	1.20	0.60	DR	42.6	28.4
				12	2	1.20	0.60	DR	2	0.70	DR	DR	28.4	18.9
				16	2	0.80	DR	DR	2	DR	DR	DR	21.3	14.2
		Nail (0.131" shank; 0.281" head)	1 1/4	8	4	2.45	1.45	0.95	4	1.60	0.85	DR	46.5	31.0
				12	4	1.60	0.85	DR	4	0.95	DR	DR	31.0	20.7
				16	4	1.10	DR	DR	3.05	0.60	DR	DR	23.3	15.5
		0.162" diameter nail	1 1/4	8	4	4	2.45	1.60	4	2.75	1.45	0.85	57.5	38.3
				12	4	2.75	1.45	0.85	4	1.65	0.75	DR	38.3	25.6
				16	4	1.90	0.95	DR	4	1.05	DR	DR	28.8	19.2
		#10 wood screw	1	12	4	2.30	1.20	0.70	4	1.40	0.60	DR	107.3	71.6
				16	4	1.65	0.75	DR	4	0.90	DR	DR	79.0	52.7
				24	4	0.90	DR	DR	2.85	DR	DR	DR	35.1	23.4
		1/4" lag screw	1 1/2	12	4	2.65	1.50	0.90	4	1.65	0.80	DR	140.4	93.6
				16	4	1.95	0.95	0.50	4	1.10	DR	DR	79.0	52.7
				24	4	1.10	DR	DR	3.25	0.50	DR	DR	35.1	23.4
Min. 33mil Steel Hat Channel or Min. 1x3 Wood Furring	33 mil Steel Stud	#8 screw (0.285" head)	Steel thickness +3 threads	12	3	1.80	DR	DR	3	0.65	DR	DR	52.9	35.3
				16	3	1	DR	DR	2.85	DR	DR	DR	39.7	26.5
				24	2.85	DR	DR	DR	2.20	DR	DR	DR	26.5	17.6
		#10 screw (0.333" head)	Steel thickness +3 threads	12	4	2.25	0.70	DR	3.70	1.05	DR	DR	62.9	41.9
				16	3.85	1.45	DR	DR	3.40	DR	DR	DR	47.1	31.4
				24	3.40	DR	DR	DR	2.70	DR	DR	DR	31.4	21.0
	43 mil or thicker Steel Stud	#8 screw (0.285" head)	Steel thickness +3 threads	12	3	1.80	DR	DR	3	0.65	DR	DR	69.0	46.0
				16	3	1	DR	DR	2.85	DR	DR	DR	51.8	34.5
				24	2.85	DR	DR	DR	2.20	DR	DR	DR	34.5	23.0
		#10 screw (0.333" head)	Steel thickness +3 threads	12	4	3.85	2.80	1.80	4	3.05	1.50	DR	81.9	54.6
				16	4	3.30	1.95	0.60	4	2.25	DR	DR	61.5	41.0
				24	4	2.25	DR	DR	4	0.65	DR	DR	35.1	23.4

SI: 1 in = 25.4 mm; 1 pound per square foot (psf) = 0.0479 kPa

- Table values are based on:
 - Minimum 3/4" (19.1 mm) thick wood furring and wood studs of Spruce-Pine-Fir or any softwood species with a specific gravity of 0.42 or greater per *AF&PA/ND*S.
 - Minimum 33 mil steel hat channel furring of 33 ksi steel. Steel hat channel shall have a minimum 7/8" (22.2 mm) depth.
 - Steel framing of indicated nominal steel thickness and minimum 33 ksi steel for 33 mil and 43 mil steel and 50 ksi steel for 54 mil steel or thicker.
- Self-drilling, self-tapping screw fasteners for connection of siding to steel framing shall comply with the requirements of *AISI S200*. Other approved fasteners of equivalent or greater diameter and bending strength shall be permitted.
- Nail fasteners shall comply with *ASTM F1667*, except nail length shall be permitted to exceed *ASTM F1667* standard lengths. Screws shall comply with *ASTM C1513*.
- Furring shall be spaced a maximum of 24" o.c. in a vertical or horizontal orientation.
 - In a vertical orientation, furring shall be located over wall studs and attached with the required fastener spacing.
 - Where placed horizontally, wood furring shall be preservative treated wood in accordance with *IRC Section R317.1* or naturally durable wood and fasteners shall be corrosion resistant in accordance *IRC Section R317.3*. Steel furring shall have a minimum G60 galvanized coating.
 - Furring strips installed in a horizontal direction shall be fastened at each stud with a number of fasteners equivalent to that required by the fastener spacing. If the required nail spacing is 12" o.c. and the studs are 24" o.c., then two (2) nails would be required at each stud (24/12=2). In no case shall fasteners be spaced more than 24" (0.6 m) apart.
- Lag screws shall be installed with a standard cut washer.
- Lag screws and wood screws shall be pre-drilled in accordance with *AF&PA/ND*S.
- Approved self-drilling screws of equal or greater shear and withdrawal strength shall be permitted without pre-drilling.

Furring Material	Framing Member	Fastener Type & Min. Size	Min. Penetration into Wall Framing (in)	Fastener Spacing in Furring (in)	Max. Thickness of GreenGuard® Insulation Board (in)								Allowable Wind Pressure Resistance of Furring Attachment (psf)	
					16" o.c. Furring				24" o.c. Furring					
					Siding Weight:				Siding Weight:					
					3 psf	11 psf	18 psf	25 psf	3 psf	11 psf	18 psf	25 psf	16" o.c.	24" o.c.
<p>8. A minimum 2x wood furring shall be used where the required siding fastener penetration into wood material exceeds 3/4" (19.1 mm) and is not more than 1 1/2" (38.1 mm), unless approved deformed shank siding nails or siding screws are used to provide equivalent withdrawal strength, allowing the siding connection to be made to a 1x wood furring.</p> <p>9. Examples of cladding included in each weight category: 3 psf – vinyl siding, 11 psf – fiber cement siding, 25 psf – masonry or cultured stone. Examples are not inclusive.</p> <p>10. Max. foam thickness of 2" for 0.120" diameter nails for 3 psf cladding weight due to limiting factor of nail length.</p> <p>11. For cladding system weights exceeding 25 psf with any thickness of GreenGuard® Insulation Board, a design professional should be consulted.</p> <p>12. Foam sheathing shall have a minimum compressive strength of 15 psi, in accordance with <i>ASTM C578</i>.</p> <p>13. Linear interpolation between cladding weight categories is not permissible.</p> <p>14. DR = Design Required</p>														

5.5 The minimum fastening requirement shall be the more stringent of that required by:

- 5.5.1 Fastening schedule determined in accordance with Section 5.3 of this TER.
- 5.5.2 Fastener type, head size, diameter, spacing, and penetration into framing required by the applicable building code for the specific cladding material and the cladding manufacturer's installation instructions^{7,8}.
 - 5.5.2.1 Where the seismic provisions of *IRC Section R301.2.2* apply, the wall assembly shall not exceed the weight limits of *Section R301.2.2.1*, unless an engineered design is provided in accordance with *Section R301.1.3*.
 - 5.5.2.2 Where the seismic load provisions of *IBC Section 1613* apply, the cladding attachment shall be verified to provide resistance to meet or exceed minimum required earthquake loads.
- 5.5.3 Fastenings that are not at least equivalent to minimum required fastener characteristics described in Section 5.4.2 shall be designed to provide adequate support of cladding weight, resistance to wind loading, and seismic loads as required by the applicable building code.
- 5.5.4 For furring connections in accordance with Table 2, allowable wind load resistance shall be verified to meet or exceed the minimum required wind load of the applicable code.
 - 5.5.4.1 Refer to *IRC Table R301.2(2)* for components and cladding wind loads for the applicable wall wind zone and for an effective wind area of 10 square feet.
 - 5.5.4.2 For *IBC* required wind loads, see *IBC Section 1609*.

6 INSTALLATION

- 6.1 Installation shall comply with the manufacturer's installation instructions and this TER. In the event of a conflict between the manufacturer's installation instructions and this TER, the more restrictive shall govern.
- 6.2 *Installation Procedure*
 - 6.2.1 Verify that materials comply with the following provisions of this TER:
 - 6.2.2 GreenGuard® Insulation Boards shall comply with the requirements of Section 4.
 - 6.2.3 Wall framing materials shall comply with Section 5, specifically the minimum wood and cold-formed steel framing member requirements in the footnotes to Table 1 and Table 2, as applicable.

⁷ An example of this would be lath attachments for stucco where a maximum of 7" o.c. spacing is required.

⁸ 2018 *IRC Section R703.3* provides a prescriptive table for the attachment of furring to resist up to 30 psf design wind loading.



- 6.2.4 Cladding or furring fastener type and size, including fastener length to obtain required penetration into or through framing members, complies with the solution determined in accordance with Section 5.4.1.
 - 6.2.4.1 Where fasteners are permitted to penetrate into or fully through sheathing or nailable substrate without penetrating into framing, as specified by the manufacturer's instructions and supported by a test report, the end of the fastener shall extend a minimum of ¼" beyond the opposite face of the sheathing or nailable substrate in accordance with IRC Section R703.11.1.
- 6.2.5 Fasteners shall be installed into framing members and driven flush and snug such that gaps between layers are removed, except where a gap under the cladding fastener head is required for attachment of vinyl siding.
- 6.2.6 Fasteners shall be installed in a workmanlike manner and not over-driven, resulting in material damage or excessive distortion of cladding, furring, or GreenGuard® Insulation Board materials.
- 6.2.7 Ensure framing members or blocking are provided to allow for attachment of siding and trim materials at transitions such as corners and wall penetrations.
- 6.2.8 Ensure that a code compliant water-resistive barrier system and flashing are provided prior to or during the installation of cladding materials. Refer to DRR No. 1205-05 for construction detailing concepts.
- 6.2.9 Where required by contract documents, the project owner or owner's agent, or good practice, construct a mock-up assembly to demonstrate constructability and a proper integration of components.

7 TEST ENGINEERING SUBSTANTIATING DATA

- 7.1 *National Design Specification for Wood Construction – 2012 Edition*, American Wood Council.
- 7.2 *General Dowel Equations for Calculating Lateral Connection Values (1999)*, TR-12, American Forest & Paper Association.
- 7.3 *North American Cold-Formed Steel Specification – 2012 Edition*, American Iron & Steel Institute (AISI S100 standard).
- 7.4 New York State Energy Research and Development Authority, *Fastening Systems for Continuous Insulation*, 2010.
- 7.5 Some information contained herein is the result of testing and/or data analysis by other sources which conform to IBC Section 1703 and relevant professional engineering law. DrJ relies on accurate data from these sources to perform engineering analysis. DrJ has reviewed and found the data provided by other professional sources to be credible.
- 7.6 Where appropriate, DrJ's analysis is based on design values that have been codified into law through codes and standards (e.g., *IBC*, *IRC*, *NDS®*, and *SDPWS*). This includes review of code provisions and any related test data that aids in comparative analysis or provides support for equivalency to an intended end-use application. Where the accuracy of design values provided herein is reliant upon the published properties of commodity materials (e.g., lumber, steel, and concrete), DrJ relies upon the grade mark, stamp, and/or design values provided by raw material suppliers to be accurate and conforming to the mechanical properties defined in the relevant material standard.

8 FINDINGS

- 8.1 When used and installed in accordance with this TER and the manufacturer's installation instructions, the product(s) listed in Section 1.1 are approved for the following:
 - 8.1.1 The design procedure and installation requirements outlined in this TER may be used to attach exterior wall coverings through Kingspan® GreenGuard® Insulation Boards to wood or steel wall framing.
 - 8.1.2 IRC Section R703.3 and R703.15 through R703.16 include provisions for the attachment of cladding and/or furring over GreenGuard® Insulation Board to appropriately resist the required design wind loads.

8.2 IBC Section 104.11 (IRC Section R104.11 and IFC Section 104.9 are similar) states:

104.11 Alternative materials, design and methods of construction and equipment. The provisions of this code are not intended to prevent the installation of any material or to prohibit any design or method of construction not specifically prescribed by this code, provided that any such alternative has been *approved*. An alternative material, design or method of construction shall be *approved* where the *building official* finds that the proposed design is satisfactory and complies with the intent of the provisions of this code, and that the material, method or work offered is, for the purpose intended, not less than the equivalent of that prescribed in this code...Where the alternative material, design or method of construction is not *approved*, the *building official* shall respond in writing, stating the reasons the alternative was not *approved*.

8.3 This product has been evaluated in the context of the codes listed in Section 2 and is compliant with all known state and local building codes. Where there are known variations in state or local codes applicable to this evaluation, they are listed here.

8.3.1 No known variations

9 CONDITIONS OF USE

9.1 The attachment of cladding materials through the GreenGuard® Insulation Board described in this TER comply with the IBC and IRC, or are a code compliant alternative as specified in the codes listed in Section 2 subject to the following conditions:

- 9.1.1 Installation shall comply with the manufacturer's installation instructions and this TER. In the event of a conflict between the manufacturer's installation instructions and this TER, the more restrictive shall govern.
- 9.1.2 Installation shall be on exterior walls with code compliant wood framing or cold-formed steel framing meeting the minimum requirements as indicated in Table 1 and Table 2.
- 9.2 Where required by the *building official*, also known as the authority having jurisdiction (AHJ) in which the project is to be constructed, this TER and the installation instructions shall be submitted at the time of *permit* application.
- 9.3 Any generally accepted engineering calculations needed to show compliance with this TER shall be submitted to the AHJ for review and approval.
- 9.4 Design loads shall be determined in accordance with the building code adopted by the *jurisdiction* in which the project is to be constructed and/or by the Building Designer (e.g., *owner* or *registered design professional*).
- 9.5 At a minimum, this product shall be installed per Section 6 of this TER.
- 9.6 This product is manufactured under a third-party quality control program in accordance with IBC Section 104.4 and 110.4 and IRC Section R104.4 and R109.2.
- 9.7 The actual design, suitability, and use of this TER, for any particular building, is the responsibility of the *owner* or the owner's authorized agent. Therefore, the TER shall be reviewed for code compliance by the *building official* for acceptance.
- 9.8 The use of this TER is dependent on the manufacturer's in-plant QC, the ISO/IEC 17020 third-party quality assurance program and procedures, proper installation per the manufacturer's instructions, the *building official's* inspection, and any other code requirements that may apply to demonstrate and verify compliance with the applicable building code.

10 IDENTIFICATION

- 10.1 The product(s) listed in Section 1.1 are identified by a label on the board or packaging material bearing the manufacturer's name, product name, TER number, and other information to confirm code compliance.
- 10.2 Additional technical information can be found at kingspan.com/us/en-us.

11 REVIEW SCHEDULE

- 11.1 This TER is subject to periodic review and revision. For the most recent version of this TER, visit drjcertification.org.
- 11.2 For information on the current status of this TER, contact [DrJ Certification](#).