

Handling & Installation Recommendations

LP® SolidStart® I-Joists, LP SolidStart LVL & LP SolidStart LSL

Note: For specific strength and span information, please consult specific product brochures.
For applications with I-Joist depths over 16, please consult the Light-Frame Commercial and Multifamily Construction Tech Guide.

Important Notes

WARNING: Failure to follow proper procedures for handling, storage and installation could result in unsatisfactory performance, unsafe structures and possible collapse.

These instructions are offered as a guide to good practice in the handling, storage and installation of LP® SolidStart® I-Joists, LP SolidStart LVL & LP SolidStart LSL beams. They are, however, solely general recommendations and, in some instances, other or additional precautions may be desirable. In all cases, the procedures used should be as specified by the architect/engineer responsible for the entire building.

- This is not intended as a manual for selecting products and assumes that components and details have been specified correctly.
- Consult the LP SolidStart I-Joist, LP SolidStart LVL & LP SolidStart LSL brochures or contact your LP SolidStart products distributor for assistance.
- All rim joists, blocking, connections and temporary bracing must be installed before erectors are allowed on the structure.
- No loads other than the weight of the erectors are to be imposed on the structure before it is permanently sheathed.
- After sheathing, do not overload joists with construction materials exceeding design loads.
- LP SolidStart I-Joists, LP SolidStart LVL & LP SolidStart LSL beams must be used under dry, covered and well-ventilated interior conditions in which the equilibrated moisture content in lumber will not exceed 16% (US) or does not exceed a yearly average of 15% and does not exceed 19% at any time (CN).

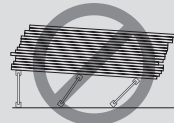

Roof Layout (typical)

TEMPORARY BRACING

- Use at least 1x4 temporary bracing members nailed to each I-Joist with two 8d nails.
- Keep the main runs parallel and no more than 8'-0" apart.
- Use long pieces, not short blocks; lap the ends to keep a continuous line of bracing.
- To prevent endwise movement of the continuous 1 x 4 lines of bracing, anchor them at the ends and at 25'-0" intervals into a stable end wall or an area braced by sheathing or diagonal bracing.
- Remember, the continuous 1 x 4 bracing is not effective unless attached to the braced area.
- Use particular care removing temporary bracing when applying sheathing. Remove the bracing as the sheathing is attached.

NOTES FOR ROOF LAYOUT:

- I-Joists used as rafters must be supported laterally at all bearings and the ends of cantilevers.
- Any fastening of member not detailed, such as uplift or seismic anchor, is subject to local approval and may require additional details and connections.
- Minimum pitch: 1/4" per foot (1/4:12). Maximum pitch: 12" per foot (12:12).
- Verify capacity and fastening of hangers and connections.

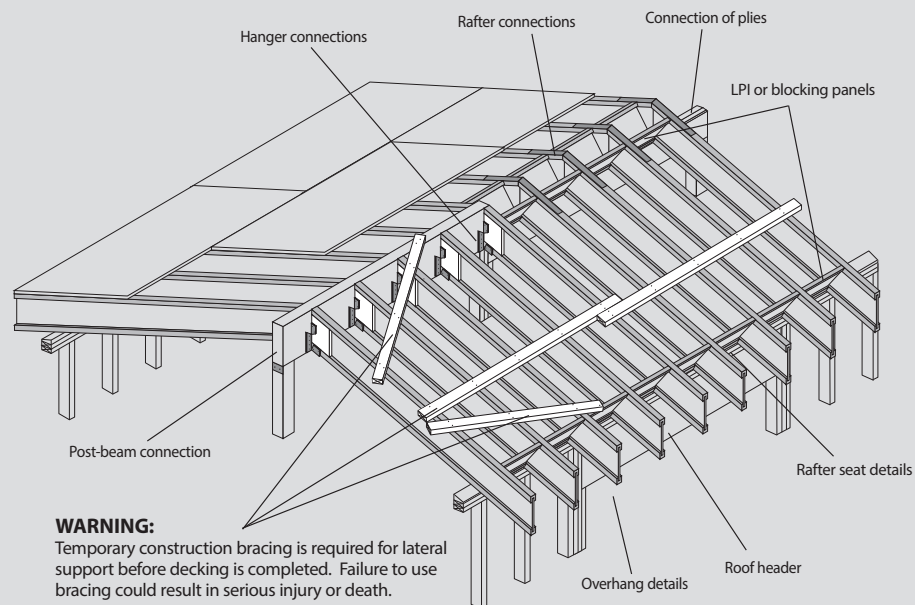

WARNING: Temporary construction bracing is required for lateral support before decking is completed. Failure to use bracing could result in serious injury or death.

Roof Details

J1 Rafter Connection

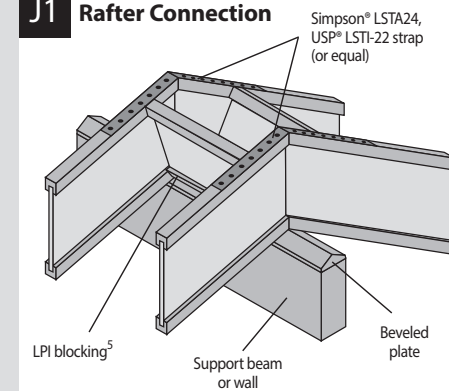

J2 Rafter Connection with Fitted OSB Gusset

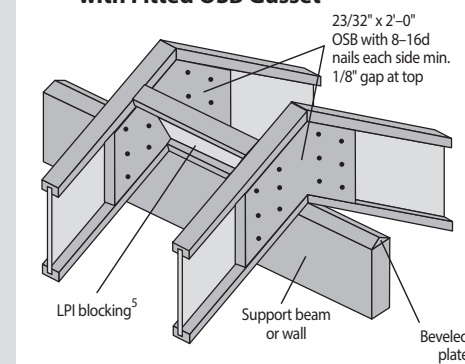

J3 Ridge Rafter Connection

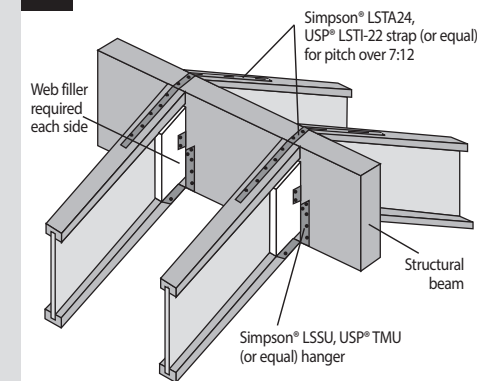

J4 Header Connection

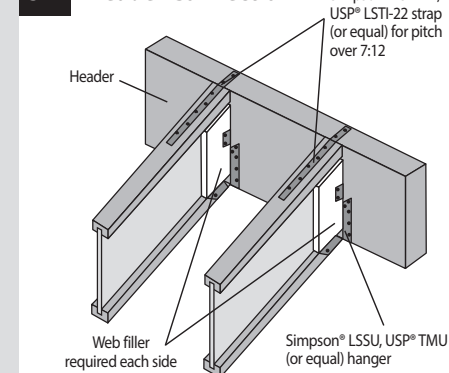

H1 Bird's Mouth (lower bearing only)

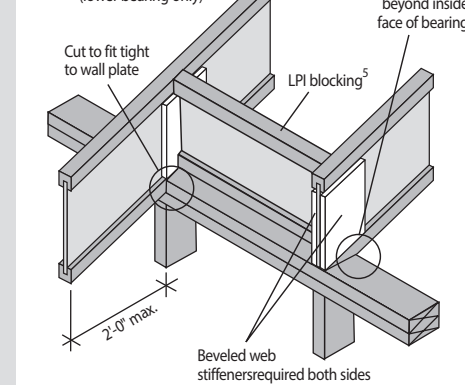

H2 Beveled Plate

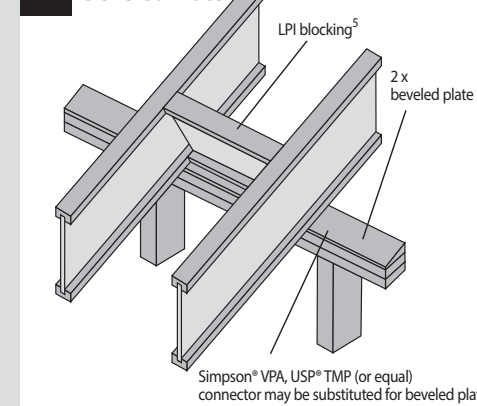

H3 Flat Soffit (Fascia support)

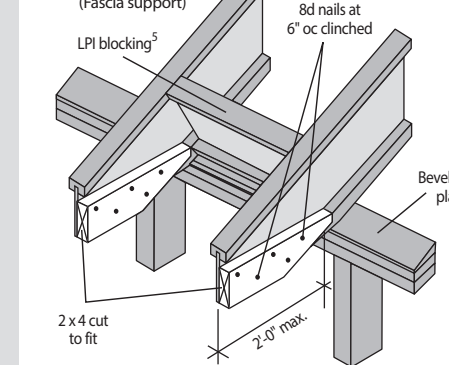

H4 Overhang

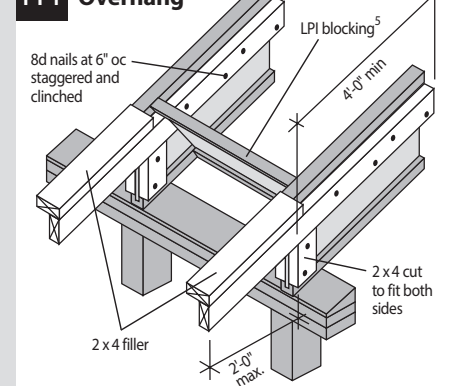

H5 Overhang

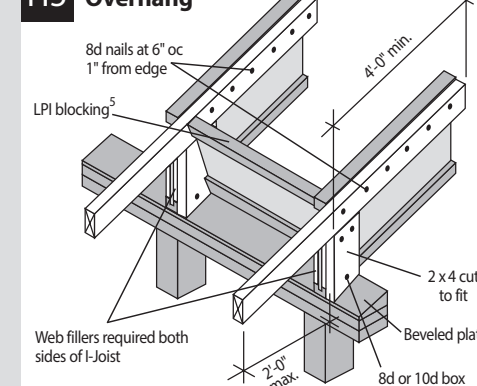

K1 Roof Opening

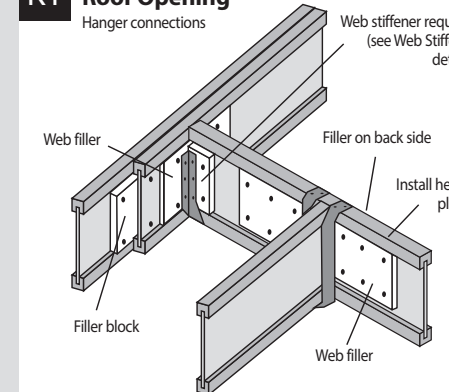

K2 Outrigger

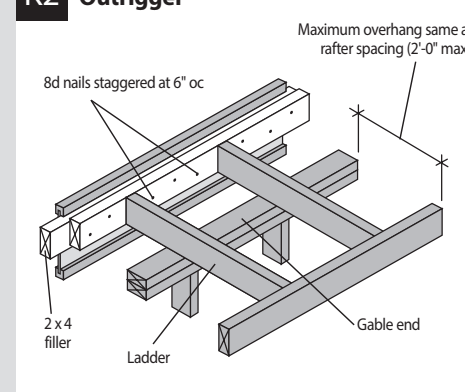

NOTES:

1. Minimum pitch: 1/4" per foot (1/4:12). Maximum pitch: 12" per foot (12:12).
2. Verify capacity and fastening requirements of hangers and connectors.
3. Some wind or seismic loads may require different or additional details and connections. Uplift anchors may be required.
4. 4" diameter hole(s) may be cut in blocking for ventilation.
5. Lateral resistance shall be provided. Other methods of restraint, such as full depth LP SolidStart OSB Rim Board, LP SolidStart LVL, LP SolidStart LSL or metal X-bracing may be substituted for the LPI blocking shown.

Handling & Storage

- Keep LP SolidStart I-Joists, LP SolidStart LVL & LP SolidStart LSL beams dry.
- Unload products carefully by lifting. Support the bundles to reduce excessive bowing. Individual products should be handled in a manner which prevents physical damage during measuring, cutting, erection, etc. I-Joists should be handled vertically and not flatwise.
- Keep stored in wrapped and strapped bundles, stacked no more than 10' high. Support and separate bundles with 2 x 4 (or larger) stickers spaced no more than 10' apart. Keep stickers in line vertically.
- Product must not be stored in contact with the ground, or have prolonged exposure to the weather.
- Use forklifts and cranes carefully to avoid damaging product.
- Do not use visually damaged product. Call your local LP SolidStart Engineered Wood Products distributor for assistance when damaged products are encountered.

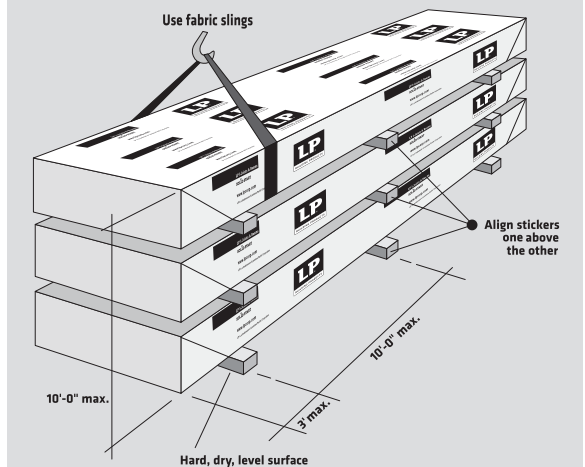

WARNING

The following conditions are NOT permitted!

Do not use visually damaged products without first checking with your local LP SolidStart Engineered Wood Products distributor or sales office.

R8

DON'T support I-Joist on web.

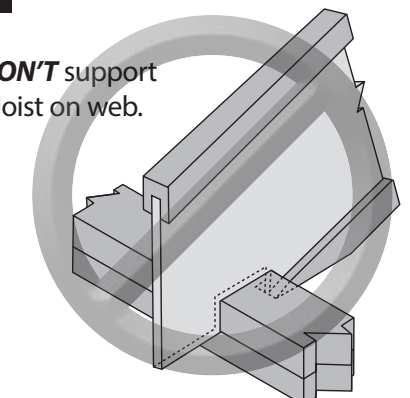

Floor Details

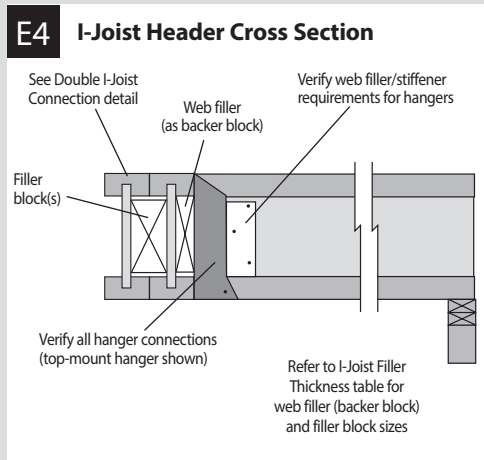
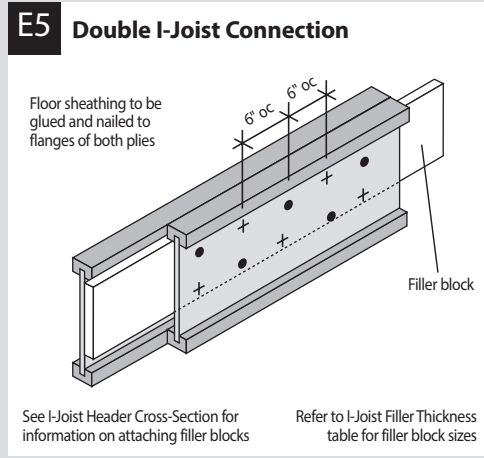
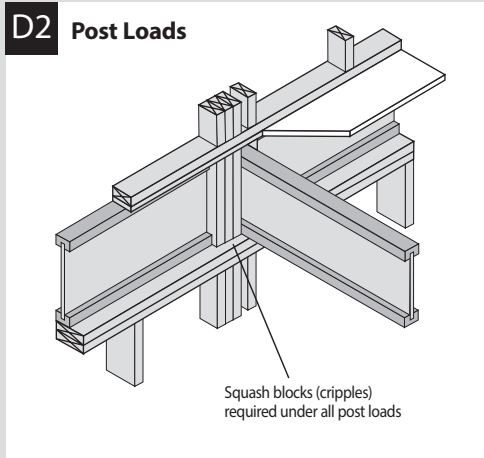
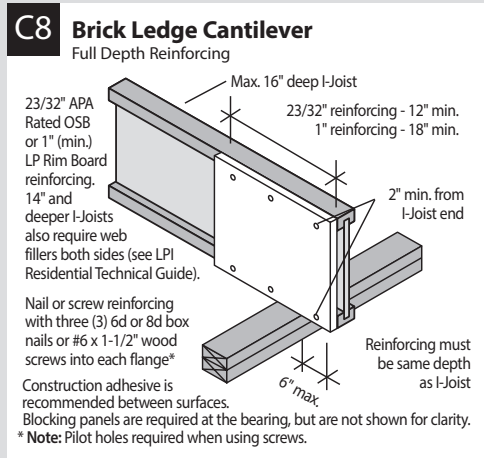
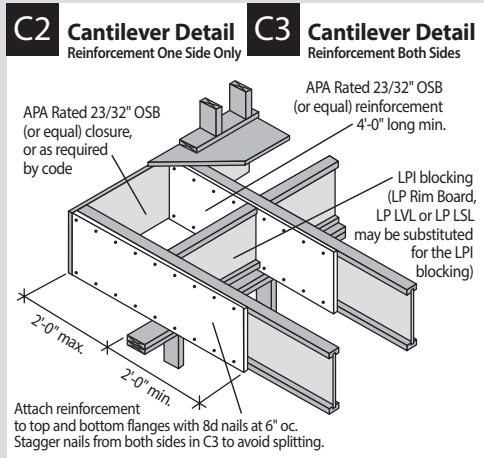
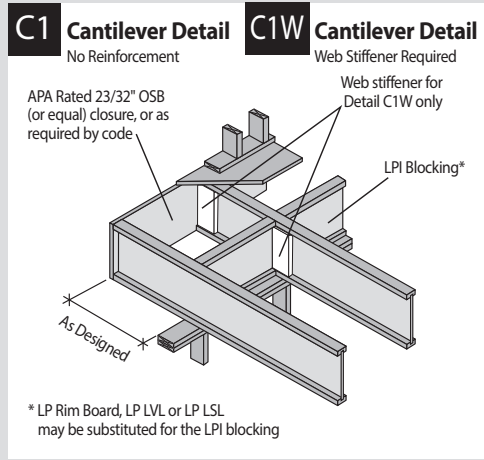
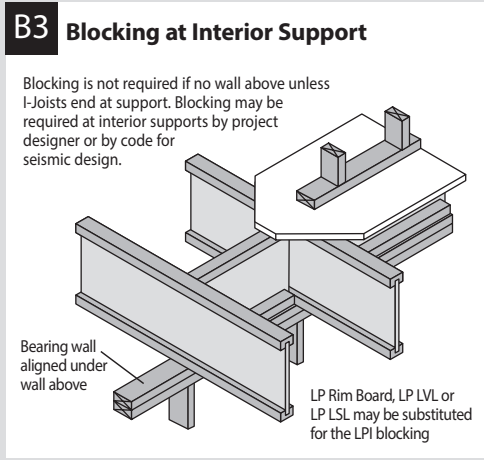
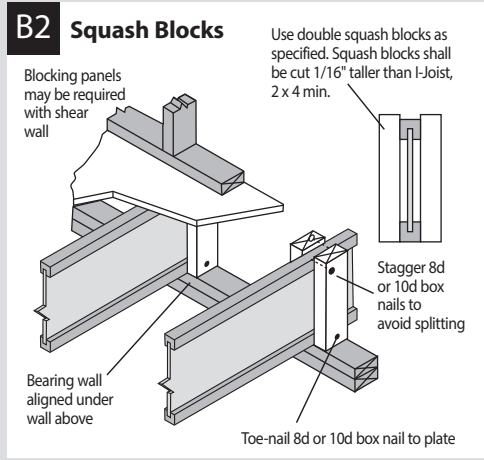
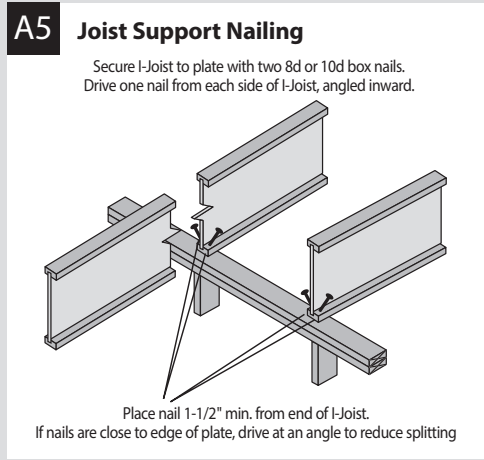
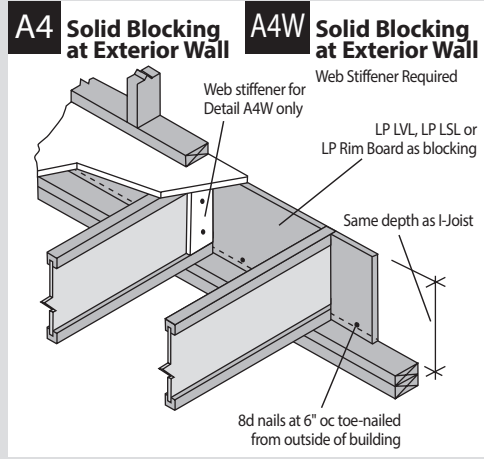
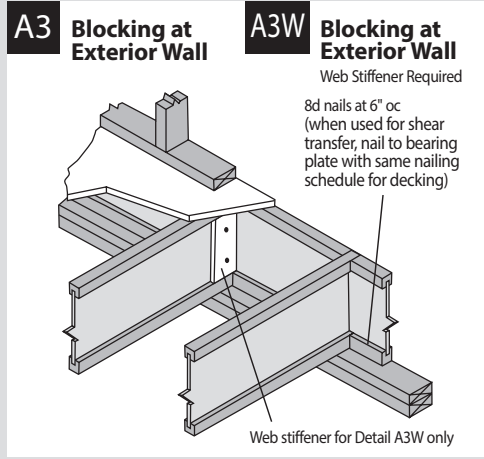
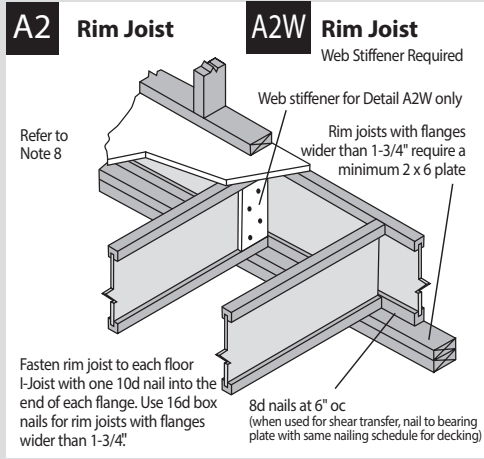
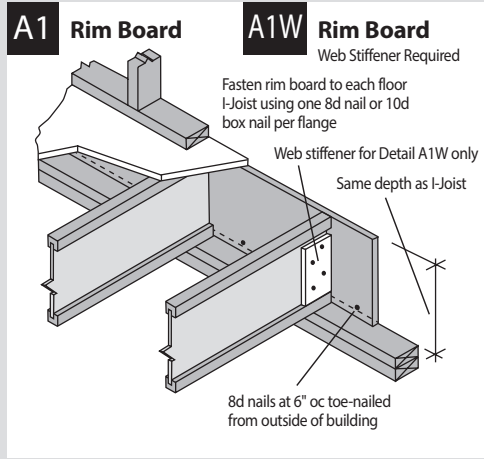

Web Filler/Backer Block: Backer blocks shall be at least 12" long and located behind every supported hanger. For a single I-joist header, install backer blocks to both sides of the web. Two pieces of 2 x 8 (min.) lumber, cut to the proper height (see notes 2 & 3), may be set vertically side-by-side to achieve the required minimum 12" length.
Attach backer blocks with 8d nails (use 10d nails for flanges wider than 2-1/2"). Use a minimum of 10 nails spaced to avoid splitting, with half the nails to each side of the center of the supported hanger.
Note: Backer blocks may be omitted for top-mount hangers supporting only downward loads not exceeding 250 lbs.
Filler Blocks: Install in minimum 4' long sections at each support, centered behind each supported hanger and at no more than 8" oc. Lumber fillers may be stacked to achieve the required depth (see notes 2 & 3). For example, two 4' long 2 x 8's may be stacked vertically to achieve the filler depth for an 18" deep I-joist (minimum required depth is 18" - 3" - 1" = 14").
Attach filler blocks with 8d nails (10d for flanges wider than 2-1/2") nails spaced 6" oc per row. Use one row of nails in each row of stacked fillers, with a minimum of two rows of nails. Drive every other nail from opposite sides.

NOTES:

- Backer blocks and filler blocks shall consist of APA Rated wood structural panel (OSB or plywood), 2 x lumber (SPF or better), or LP SolidStart LVL, LSL or OSB Rim Board, with a net thickness equivalent to that shown in the I-Joist Filler Thickness table below.
- Except as noted in 3, backer blocks and filler blocks shall fit the clear distance between flanges with a gap of at least 1/8", but not more than 1", and shall be of sufficient depth to allow for all hanger nailing into the web. Do not force into place.
- Backer blocks and filler blocks for double I-joists that are top-loaded only or side-loaded supporting top-mount hangers that do not require nailing into the web, shall be at least 5-1/2" deep for I-joists to 11-7/8" deep, and shall be at least 7-1/4" deep for I-joists 14" and deeper.
- Install backer blocks tight to top flange for top-loaded joists and for joists supporting top-mount hangers (shown). Install tight to bottom flange for joists supporting face-mount hangers.
- Cinch nails where possible.
- For double I-joists, additional nailing may be required to transfer point loads. For additional information, contact your LP SolidStart Engineered Wood Products distributor.

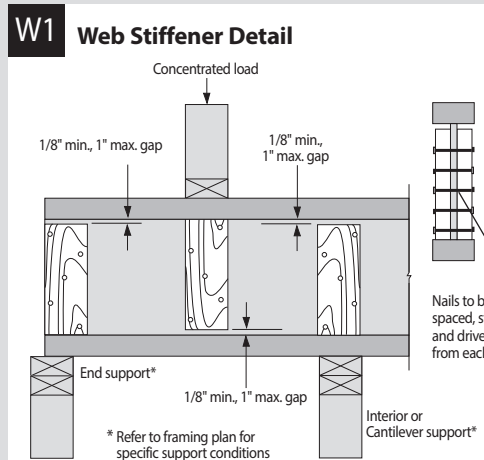

Floor Layout (typical)

TEMPORARY BRACING

- Use at least 1x4 temporary bracing members nailed to each I-Joist with two 8d nails.
- Keep the main runs parallel and no more than 8'-0" apart.
- Use long pieces, not short blocks; lap the ends to keep a continuous line of bracing.
- To prevent endwise movement of the continuous 1 x 4 lines of bracing, anchor them at the ends and at 25'-0" intervals into a stable end wall or an area braced by sheathing or diagonal bracing.
- Remember, the continuous 1 x 4 bracing is not effective unless attached to the braced area.
- Use particular care removing temporary bracing when applying sheathing. Remove the bracing as the sheathing is attached.

NOTES FOR FLOOR LAYOUT:

- I-Joists must be supported laterally at all bearings and the ends of cantilevers.
- Unless specified, bridging or mid-span blocking is not required; however, it may enhance floor performance if used properly.
- Verify capacity and fastening of hangers and connectors.
- Some wind or seismic loads may require different or additional details and connections.

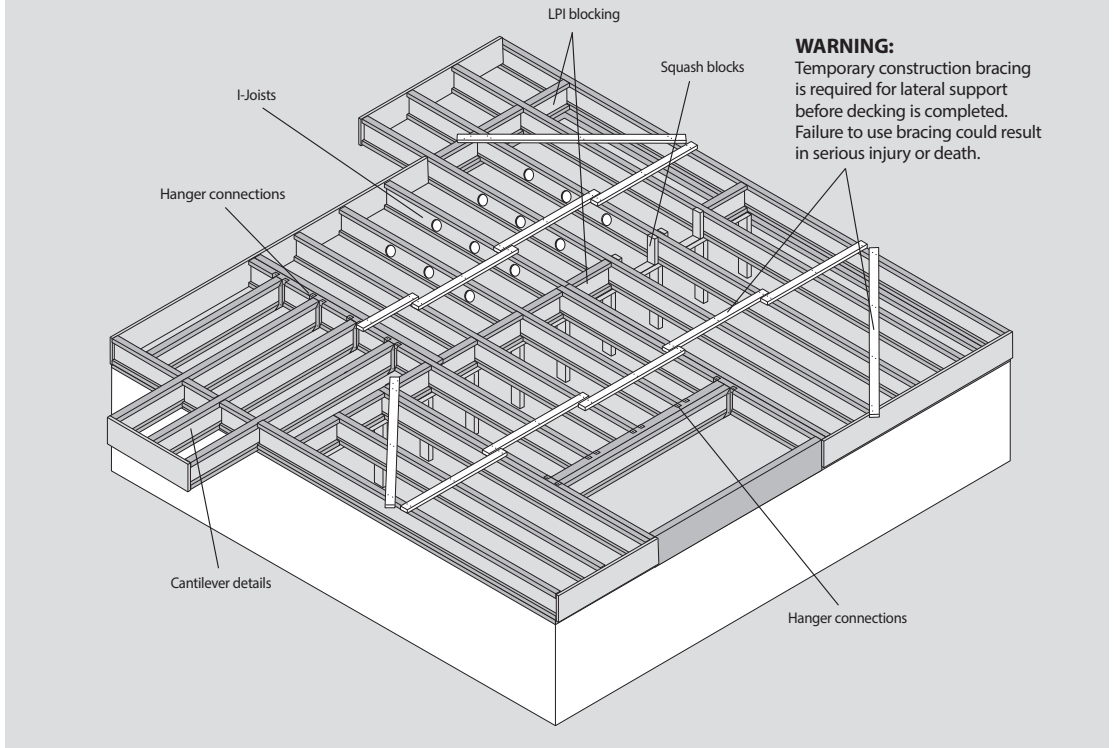

I-JOIST FILLER THICKNESS		
SERIES	FILLER BLOCK	WEB FILLER/BACKER BLOCK
LPI 18, LPI 20Plus, LPI 32Plus	2-1/8"	1"
LPI 20FB	1-1/2"	23/32"
LPI 36	1-7/8"	7/8"
LPI 42FB	2-1/2"	1-1/4"
LPI 42Plus, LPI 52Plus, LPI 56	3"	1-1/2"
LPI 450	1-1/2"	23/32"
LPI 530	1-3/4"	7/8"

NOTES:

- Backer blocks and filler blocks shall consist of APA Rated wood structural panel (OSB or plywood), or 2x lumber (SPF or better).
- LP LVL, LSL or OSB Rim Board may also be used.
- Refer to the Notes for the I-Joist Header Cross-Section to the left for details on the required height and length, and nailing of the backer blocks and filler blocks.

WEB STIFFENER REQUIREMENTS						
SERIES	MIN. THICKNESS	NAIL SIZE	NAIL QTY., MAX. STIFFENER HEIGHT FOR JOIST DEPTHS			
			9-1/2"	11-7/8"	14"	16"
LPI 18, LPI 20Plus, LPI 32Plus, LPI 450, LPI 530	23/32"	8d (2-1/2")	3, 6-3/8"	3, 8-3/4"	3, 10-7/8"	3, 12-7/8"
LPI 36	23/32"	8d (2-1/2")	-	4, 8-3/4"	5, 10-7/8"	6, 12-7/8"
LPI 42Plus, LPI 52Plus	1-1/2" (2x)	10d (3")	3, 6-3/8"	3, 8-3/4"	3, 10-7/8"	3, 12-7/8"
LPI 56	1-1/2" (2x)	10d (3")	-	4, 8-3/4"	5, 10-7/8"	6, 12-7/8"

NOTE: Web stiffeners are not applicable to the LPI 20FB and LPI 42FB series.

NOTES:

- Web stiffeners shall be installed in pairs – one to each side of the web. Web stiffeners are always required for the "Bird's Mouth" roof joist bearing detail.
- Web stiffeners shall be cut to fit between the flanges of the LP SolidStart I-Joist, leaving a minimum 1/8" gap (1" maximum). At bearing locations, the stiffeners shall be installed tight to the bottom flange. At locations of concentrated loads, the stiffeners shall be installed tight to the top flange.
- Web stiffeners shall be cut from APA Rated OSB (or equal) or from LP SolidStart LVL, LSL or OSB Rim Board. 2x lumber is permissible. Do NOT use 1x lumber as it tends to split. Do NOT build up the required stiffener thickness from multiple pieces.
- Web stiffeners shall be the same width as the bearing surface, with a minimum of 3-1/2"
- See Web Stiffener Requirements for minimum stiffener thickness, maximum stiffener height and required nailing.

Web Hole Details

WARNING: Do NOT cut or notch flanges.

Uncut length of web between adjacent holes shall be at least twice the largest dimension of the two holes or 12" center-to-center, whichever is greater.

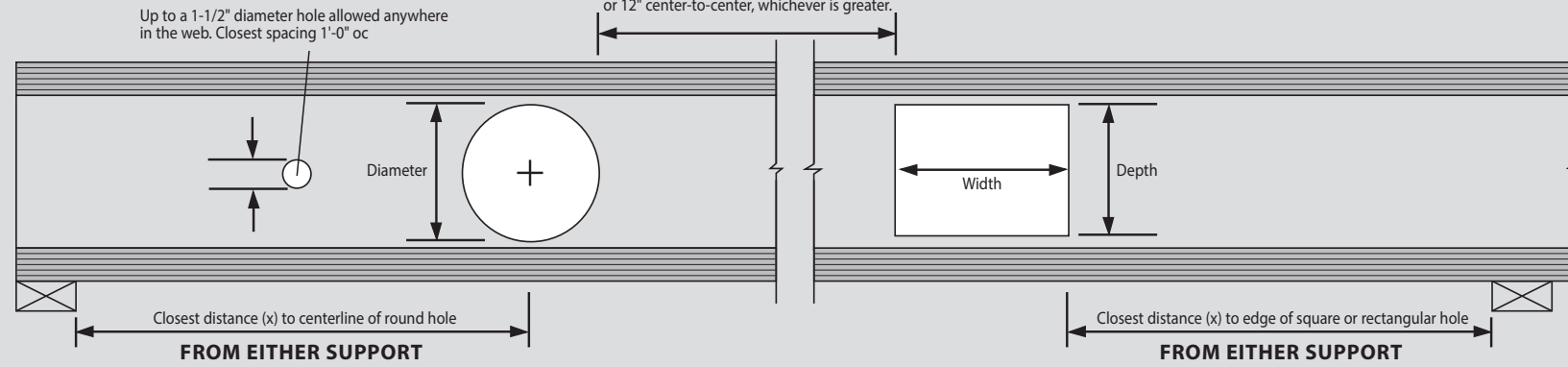

CLOSEST DISTANCE (X) - (FT - IN)

SERIES	DEPTH	CIRCULAR HOLE DIAMETER										
		2"	3"	4"	5"	6"	7"	8"	9"	10"	11"	12"
LPI 18	9-1/2"	1'-2"	1'-10"	2'-7"	3'-3"	4'-3"	-	-	-	-	-	-
	11-7/8"	1'-0"	1'-5"	2'-9"	3'-6"	4'-3"	5'-5"	-	-	-	-	-
LPI 20Plus LPI 20FB	9-1/2"	1'-0"	1'-0"	1'-5"	2'-0"	2'-8"	-	-	-	-	-	-
	11-7/8"	1'-0"	1'-4"	1'-11"	2'-5"	2'-11"	3'-6"	4'-0"	-	-	-	-
	14"	1'-3"	1'-8"	2'-2"	2'-7"	3'-1"	3'-6"	4'-0"	4'-6"	5'-1"	-	-
LPI 32Plus	16"	1'-8"	2'-1"	2'-6"	2'-11"	3'-4"	3'-9"	4'-3"	4'-8"	5'-1"	5'-7"	6'-3"
	9-1/2"	1'-0"	1'-2"	1'-11"	2'-9"	3'-6"	-	-	-	-	-	-
	11-7/8"	1'-1"	1'-9"	2'-5"	3'-0"	3'-8"	4'-4"	5'-0"	-	-	-	-
	14"	1'-8"	2'-3"	2'-10"	3'-5"	4'-0"	4'-8"	5'-3"	5'-11"	6'-7"	-	-
LPI 42Plus LPI 42FB	16"	2'-4"	2'-10"	3'-4"	3'-11"	4'-5"	4'-11"	5'-6"	6'-1"	6'-8"	7'-4"	8'-2"
	9-1/2"	1'-3"	2'-3"	3'-4"	4'-4"	5'-5"	-	-	-	-	-	-
	11-7/8"	3'-2"	3'-10"	4'-7"	5'-3"	6'-0"	6'-9"	7'-8"	-	-	-	-
LPI 52Plus	14"	4'-5"	5'-0"	5'-7"	6'-1"	6'-8"	7'-3"	8'-0"	8'-10"	9'-11"	-	-
	16"	5'-4"	5'-10"	6'-4"	6'-10"	7'-4"	7'-10"	8'-6"	9'-3"	10'-0"	11'-0"	12'-3"
	11-7/8"	5'-0"	5'-6"	6'-2"	6'-9"	7'-5"	8'-2"	8'-11"	-	-	-	-
LPI 36	14"	6'-1"	6'-7"	7'-1"	7'-7"	8'-3"	8'-11"	9'-8"	10'-6"	11'-4"	-	-
	16"	7'-1"	7'-6"	7'-11"	8'-5"	9'-0"	9'-8"	10'-5"	11'-3"	12'-1"	12'-11"	13'-9"
	11-7/8"	1'-0"	2'-0"	3'-0"	4'-0"	5'-1"	6'-2"	7'-6"	-	-	-	-
LPI 56	14"	1'-10"	2'-8"	3'-7"	4'-5"	5'-4"	6'-3"	7'-3"	8'-6"	9'-11"	-	-
	16"	2'-2"	3'-1"	3'-11"	4'-9"	5'-7"	6'-5"	7'-4"	8'-4"	9'-7"	10'-11"	12'-5"
	11-7/8"	3'-9"	4'-9"	5'-9"	6'-9"	7'-9"	8'-10"	9'-11"	-	-	-	-
LPI 450	14"	4'-10"	5'-9"	6'-8"	7'-7"	8'-7"	9'-7"	10'-7"	11'-7"	12'-10"	-	-
	16"	6'-0"	6'-11"	7'-9"	8'-8"	9'-7"	10'-5"	11'-4"	12'-2"	13'-3"	14'-4"	15'-11"
	11-7/8"	1'-0"	1'-5"	2'-5"	3'-6"	4'-6"	5'-7"	7'-2"	-	-	-	-
LPI 530	14"	1'-0"	1'-2"	1'-8"	2'-4"	3'-4"	4'-5"	5'-7"	6'-10"	8'-8"	-	-
	16"	6'-0"	6'-11"	7'-9"	8'-8"	9'-7"	10'-5"	11'-4"	12'-2"	13'-3"	14'-4"	15'-11"
	9-1/2"	1'-3"	2'-5"	3'-7"	4'-9"	6'-0"	-	-	-	-	-	-
LPI 530	11-7/8"	1'-0"	1'-7"	2'-6"	3'-8"	4'-11"	6'-2"	7'-9"	-	-	-	-
	14"	1'-0"	1'-3"	1'-11"	2'-8"	3'-9"	4'-11"	6'-1"	7'-6"	9'-4"	-	-
	16"	1'-0"	1'-2"	1'-8"	2'-2"	2'-11"	4'-0"	5'-1"	6'-2"	7'-4"	8'-10"	11'-2"
SERIES	DEPTH	RECTANGULAR HOLE MAXIMUM DIMENSION: DEPTH OR WIDTH										
		2"	3"	4"	5"	6"	7"	8"	9"	10"	11"	12"
LPI 18	9-1/2"	2'-7"	3'-0"	3'-7"	4'-3"	5'-4"	5'-9"	6'-1"	6'-7"	7'-1"	7'-7"	8'-1"
	11-7/8"	3'-5"	3'-10"	4'-4"	4'-11"	5'-10"	7'-0"	8'-11"	9'-6"	10'-2"	10'-10"	-
LPI 20Plus LPI 20FB	9-1/2"	2'-10"	3'-4"	3'-10"	4'-7"	5'-9"	6'-2"	6'-8"	7'-2"	7'-8"	8'-3"	8'-9"
	11-7/8"	3'-9"	4'-2"	4'-9"	5'-5"	6'-5"	7'-9"	9'-8"	10'-4"	11'-0"	11'-8"	12'-6"
	14"	1'-2"	1'-10"	2'-6"	3'-2"	3'-11"	4'-8"	5'-7"	6'-10"	9'-0"	9'-11"	11'-1"
LPI 32Plus	16"	1'-7"	2'-3"	2'-11"	3'-7"	4'-3"	4'-11"	5'-8"	6'-8"	8'-2"	10'-6"	14'-5"
	9-1/2"	3'-8"	4'-4"	5'-0"	6'-0"	7'-5"	7'-9"	8'-2"	8'-7"	9'-1"	9'-6"	10'-0"
	11-7/8"	4'-8"	5'-3"	6'-0"	6'-11"	8'-1"	9'-8"	11'-5"	12'-0"	12'-6"	13'-3"	14'-0"
	14"	1'-7"	2'-5"	3'-4"	4'-2"	5'-1"	6'-0"	7'-2"	8'-11"	11'-8"	12'-7"	13'-7"
LPI 42Plus LPI 42FB	16"	2'-2"	3'-0"	3'-10"	4'-8"	5'-6"	6'-5"	7'-5"	8'-9"	10'-8"	13'-9"	17'-2"
	9-1/2"	5'-8"	6'-6"	7'-4"	8'-2"	9'-3"	9'-7"	9'-11"	10'-4"	10'-9"	11'-3"	11'-9"
	11-7/8"	7'-2"	8'-0"	9'-0"	10'-0"	10'-11"	12'-1"	13'-8"	14'-3"	14'-11"	15'-7"	16'-6"
LPI 52Plus	14"	4'-4"	5'-2"	6'-0"	6'-10"	7'-10"	9'-1"	10'-10"	12'-7"	14'-7"	15'-4"	16'-3"
	16"	5'-3"	6'-0"	6'-9"	7'-7"	8'-6"	9'-8"	11'-2"	13'-1"	15'-1"	17'-4"	20'-7"
	11-7/8"	8'-6"	9'-2"	9'-11"	10'-8"	11'-8"	12'-10"	14'-5"	15'-0"	15'-8"	16'-6"	17'-4"
LPI 36	14"	6'-0"	6'-9"	7'-6"	8'-5"	9'-6"	10'-8"	11'-11"	13'-5"	15'-5"	16'-3"	17'-1"
	16"	7'-0"	7'-7"	8'-5"	9'-4"	10'-5"	11'-8"	13'-0"	14'-4"	16'-0"	18'-2"	21'-5"
	11-7/8"	6'-7"	7'-4"	8'-1"	8'-10"	9'-8"	10'-9"	12'-1"	12'-7"	13'-2"	13'-10"	14'-7"
LPI 56	14"	3'-8"	4'-6"	5'-5"	6'-3"	7'-2"	8'-5"	9'-9"	11'-2"	12'-11"	13'-7"	14'-4"
	16"	4'-4"	5'-2"	6'-0"	6'-11"	7'-10"	8'-11"	10'-3"	11'-8"	13'-3"	15'-1"	17'-10"
	11-7/8"	9'-2"	9'-9"	10'-5"	11'-3"	12'-3"	13'-6"	15'-2"	15'-10"	16'-7"	17'-3"	18'-2"
LPI 450	14"	6'-10"	7'-8"	8'-7"	9'-7"	10'-6"	11'-5"	12'-8"	14'-2"	16'-3"	17'-0"	18'-0"
	16"	8'-3"	9'-2"	10'-0"	10'-11"	11'-9"	12'-9"	13'-9"	15'-1"	16'-9"	19'-0"	22'-5"
	11-7/8"	4'-10"	5'-5"	6'-2"	7'-1"	8'-1"	9'-2"	10'-4"	10'-10"	11'-4"	11'-11"	-
LPI 530	14"	3'-0"	3'-9"	4'-7"	5'-5"	6'-3"	7'-3"	8'-8"	10'-5"	12'-3"	12'-10"	13'-8"
	16"	4'-1"	4'-10"	5'-6"	6'-4"	7'-3"	7'-6"	7'-10"	8'-2"	8'-6"	8'-11"	9'-4"
	11-7/8"	5'-2"	5'-10"	6'-7"	7'-7"	8'-6"	9'-6"	10'-9"	11'-3"	11'-9"	12'-3"	12'-11"
LPI 530	14"	3'-4"	4'-1"	5'-0"	5'-10"	6'-9"	7'-10"	9'-3"	10'-10"	12'-6"	13'-3"	14'-0"
	16"	4'-2"	4'-11"	5'-8"	6'-5"	7'-3"	8'-3"	9'-6"	11'-2"	12'-11"	14'-10"	17'-6"

NOTES:

- CUT HOLES CAREFULLY! DO NOT OVERCUT HOLES! DO NOT CUT JOIST FLANGES!
- Holes may be placed anywhere within the depth of the web. A minimum 1/4" clear distance from the flanges is recommended so as not to cut a flange.
- Round holes up to 1-1/2" diameter may be placed anywhere in the web.
- Perforated "knockouts" may be neglected when locating web holes.
- Holes larger than 1-1/2" are not permitted in cantilevers without special engineering.
- Multiple holes shall have a clear separation along the length of the joist of at least twice the larger dimension of the larger adjacent hole, or a minimum of 12" center-to-center, whichever is greater.
- Multiple holes may be spaced closer provided they fit within the boundary of an acceptable larger hole. Example: two 3" round holes aligned parallel to the joist length may be spaced 2" apart (clear distance) provided that a 3" high by 8" long rectangle or an 8" diameter round hole are acceptable for the joist depth at that location and completely encompass the holes.
- These web hole tables are valid for simple and continuous span I-joists with uniform loads only, as sized from the tables contained in LP's current I-joist product guides. Larger holes, non-uniform loading conditions and/or closer proximity to supports may be possible, but require further analysis using LP's design software. Please contact your local LP SolidStart Engineered Wood Products distributor for more details.
- The maximum hole depth is the I-joist Depth less 4", except the maximum hole depth is 6" for 9-1/2" LP I-joists, and 8" for 11-7/8" LP I-joists. Where the Maximum Hole Dimension exceeds the hole depth, the dimension refers to hole width and the depth of the hole is assumed to be the maximum for that joist depth. The maximum hole width is 18", regardless of I-joist Depth.

Beam Hole Details

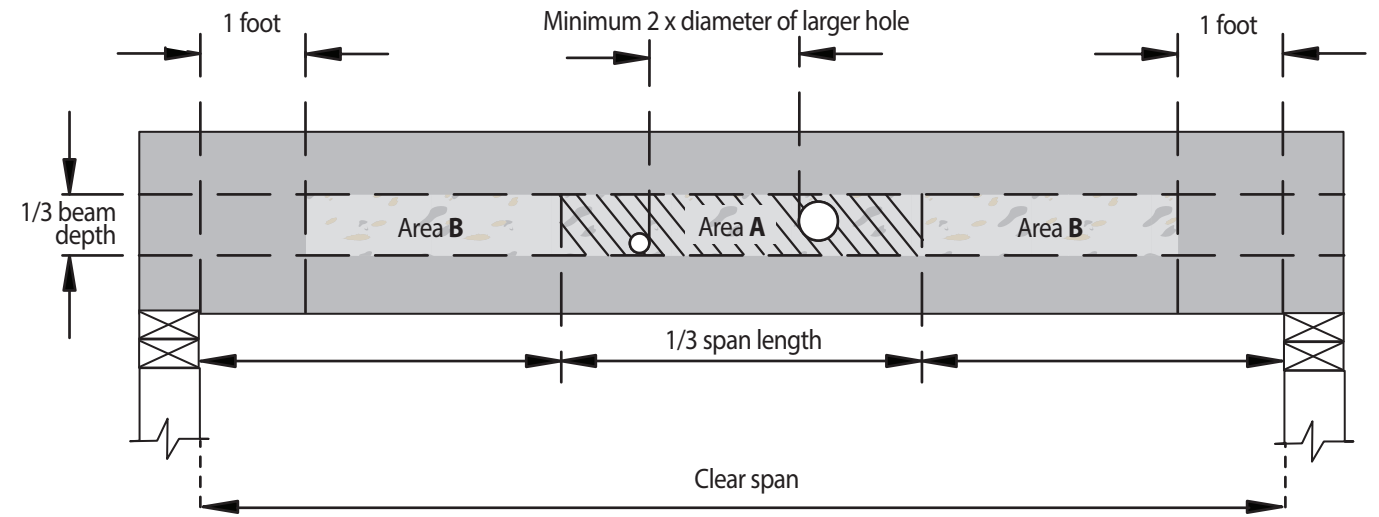

NOTES:

- These guidelines apply to uniformly loaded beams selected from the Quick Reference Tables or the Uniform Load Tables or designed with LP's design/specification software only. For all other applications, such as beams with concentrated loads, please contact your LP SolidStart Engineered Wood Products distributor for assistance.
- Round holes can be drilled anywhere in "Area A" provided that: no more than four holes are cut, with the minimum spacing described in the diagram. The maximum hole size is 1-1/2" for depths up to 9-1/4", and 2" for depths greater than 9-1/4".
- Rectangular holes are NOT allowed.
- DO NOT drill holes in cantilevers without prior approval from the project engineer/architect.
- Other hole sizes and configurations MAY be possible with further engineering analysis. For more information, contact your LP SolidStart Engineered Wood Products distributor.
- Up to three 3/4" holes may be drilled in "Area B" to accommodate wiring and/or water lines. These holes must be at least 12" apart. The holes should be located in the middle third of the depth, or a minimum of 3" from the bottom and top of the beam. For beams shallower than 9-1/4", locate holes at mid-depth.
- Protect plumbing holes from moisture.

WARNINGS

The following conditions are NOT permitted!

Do not use visually damaged products without first checking with your local LP SolidStart Engineered Wood Products distributor or sales office.

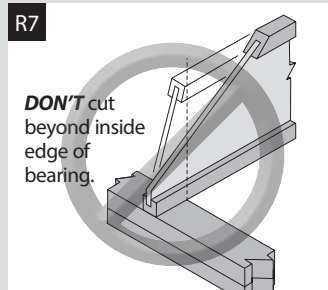
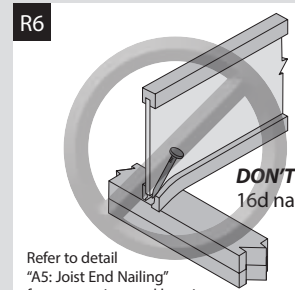
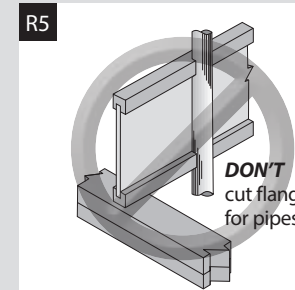
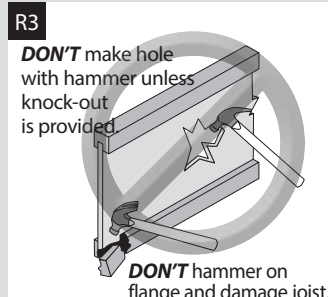
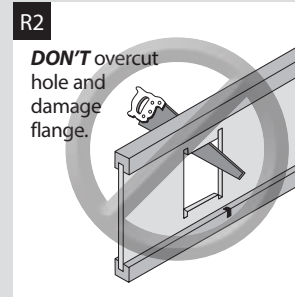
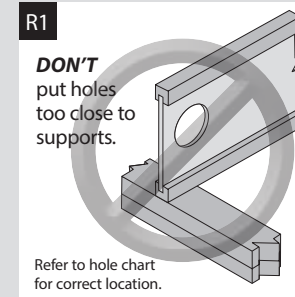
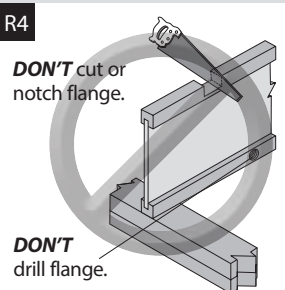

FLANGE FACE NAILING SCHEDULE

SERIES	NAIL SIZE AND TYPE	MINIMUM NAIL DISTANCE		SERIES	NAIL SIZE AND TYPE	MINIMUM NAIL DISTANCE	
		OC SPACING	END			OC SPACING	END
LPI 18	8d (2-1/2") Box or Common	2"	1"	LPI 36	8d (2-1/2") Box or Common	3"	1-1/2"
LPI 20Plus	10d (3") or 12d (3-1/4") Box	2"	1"	LPI 56	10d (3") or 12d (3-1/4") Box	3"	1-1/2"
LPI 32Plus	10d (3") or 12d (3-1/4") Common	3"	1-1/2"	LPI 450	10d (3") or 12d (3-1/4") Common	3"	1-1/2"
LPI 42Plus	16d Sinker (3-1/4")	3"	1-1/2"	LPI 52Plus	16d Sinker (3-1/4")	3"	1-1/2"
LPI 20FB	16d (3-1/2") Box or Common	4"	1-1/2"	LPI 530	16d (3-1/2") Box or Common	5"	1-1/2"
LPI 42FB	16d (3-1/2") Box or Common	4"	1-1/2"				

NOTES:

- Some wind or seismic loads may require different or additional details and connections.
- Verify building code requirements for suitability of details shown.
- Refer to LPI Product Guides for bearing length requirements.
- Refer to Flange Nailing Schedule for rim joist and blocking panel nailing.
- Lateral support shall be considered for bottom flange when there is no sheathing on underside.
- Verify capacity and fastening requirements of hangers and connectors.
- Squash block capacity designed by others.
- Do not use rim joists with flanges wider than 2-1/2".

Stair Stringer Details

G1 Stair Stringer - Top Support - Ledger

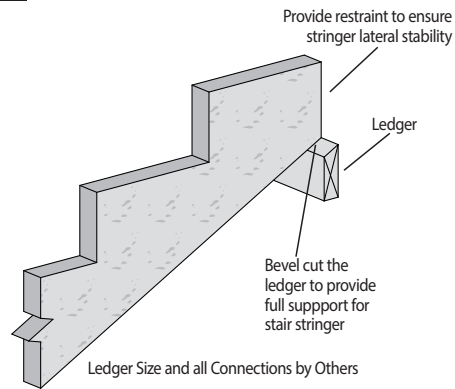

G2 Stair Stringer - Top Support - Connector

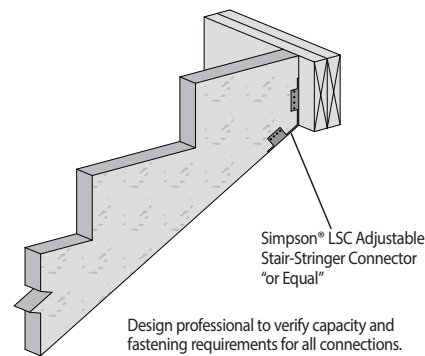

G3 Stair Stringer - Bottom Support - Concrete

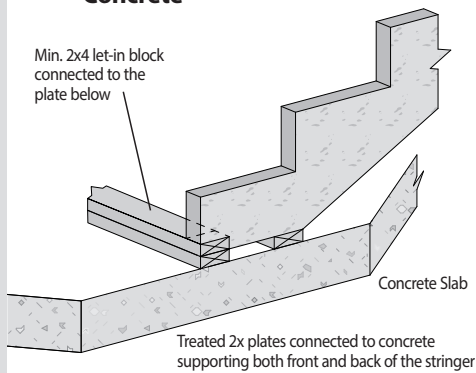

G4 Stair Stringer - Bottom Support - Beam

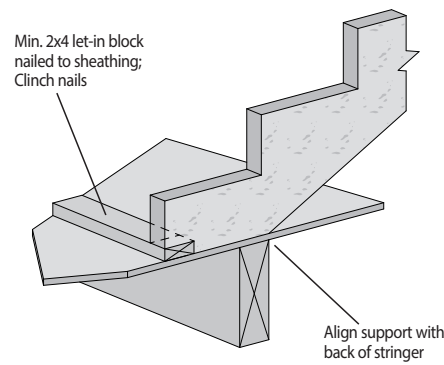

G5 Stair Stringer - Bottom Support - Ledger

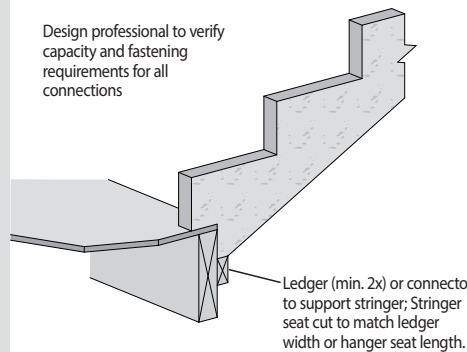

Warnings

The following conditions are NOT permitted!

Do not use visually damaged products without first checking with your local LP SolidStart Engineered Wood Products distributor or sales office.

LP SolidStart LVL & LSL Details

P1 Top Loaded Beam - Nailed Connection

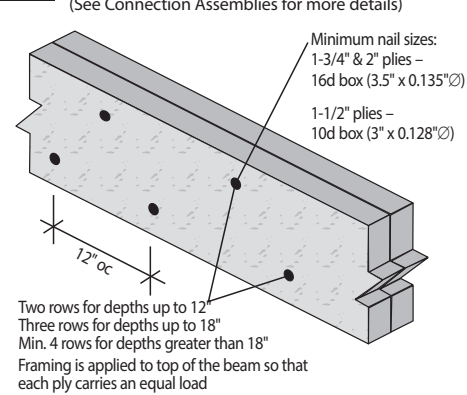

P2 Top Loaded Beam - Bolted Connection

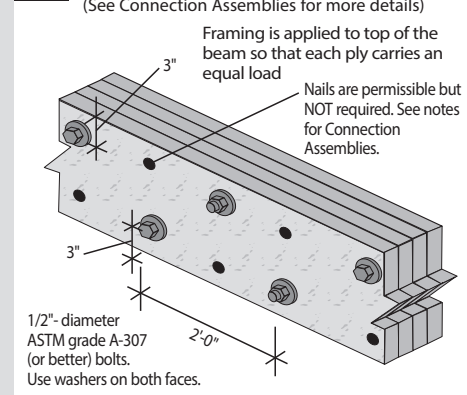

P3 Beam Connection

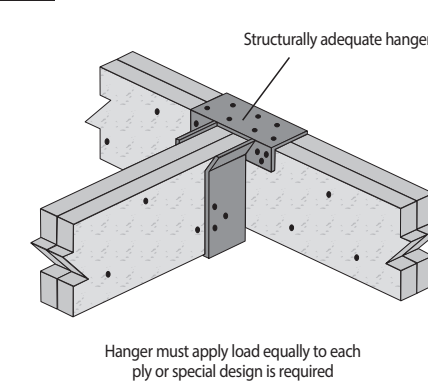

P4 Steel Column & Wood Column

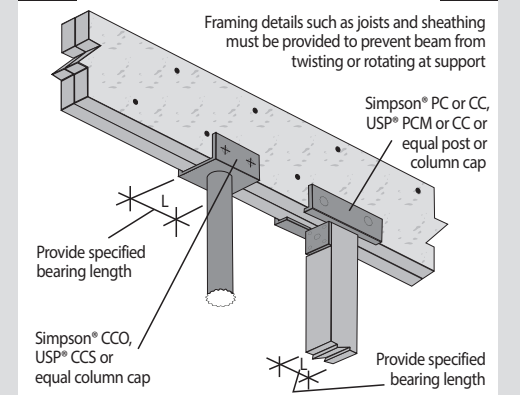

P6 Side Loaded Beam

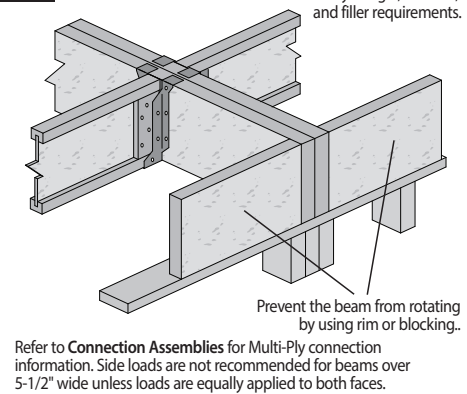

P7 Concrete Wall

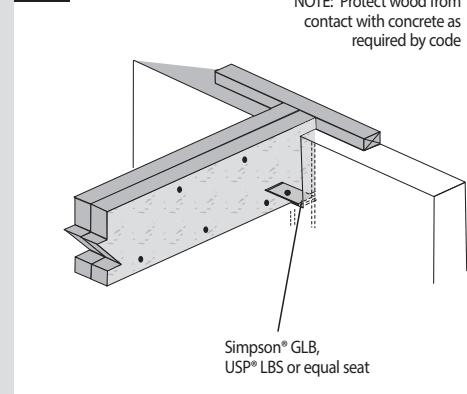

Q1 Window/Door Header

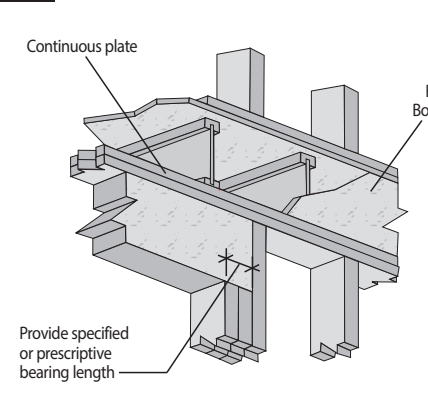

Q4 Masonry Hanger

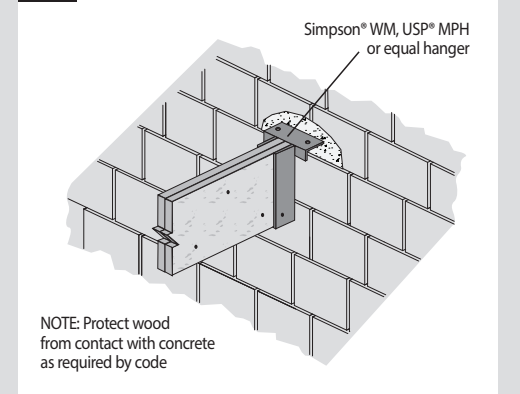

CONNECTION ASSEMBLIES

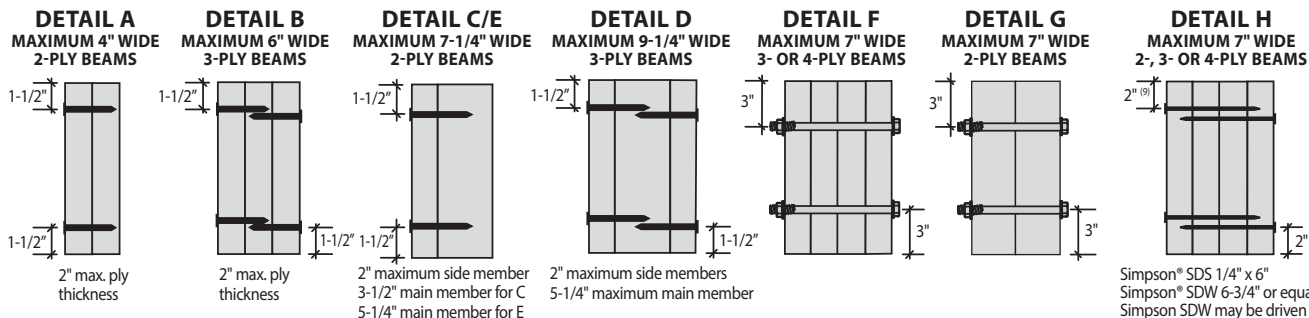

- ### NOTES:
- Use 2 rows of nails for depths to 12". Use 3 rows of nails for depths greater than 12" up to 18". Use 4 rows of nails for depths greater than 18" up to 24".
 - 16d box (3-1/2" x 0.135") or common (3-1/2" x 0.162") nails shall be used for 1-3/4" and 2" thick plies. 10d box (3" x 0.128") or common (3" x 0.148") nails shall be used for 1-1/2" thick plies. 16d sinkers (3-1/4" x 0.148") may be used for 1-3/4" and 2" plies provided the nails are driven alternating from each face (see note 3).
 - For detail A or when attaching the first two plies for details B and F (optional), the nails may be driven all from one face or alternating from both faces. If the nails do not fully penetrate the second ply, then the nails shall be driven from both faces.
 - When driving nails from each face, alternate every other nail in each row.
 - For detail C/E, when side-loaded, the larger side-load shall be applied to the thicker ply (main member).
 - For details F and H, it is permissible to nail the plies together before bolting or driving Simpson SDS or SDW (or equal) screws. Nail two plies together then nail one additional ply to each side.
 - Beams wider than 5-1/2" shall be top-loaded or side-loaded from both sides to prevent rotation. Consult a professional engineer for other options.
 - Other nail, screw or bolt configurations are possible. Contact your LP SolidStart Engineered Wood Products distributor.
 - Minimum of 2" or the screw mfg's edge distance.

R9

DON'T bore holes or notch unless reviewed by a design professional.

Exception: Small holes may be drilled in accordance with the Beam Hole Details.

R10 DON'T Overcut Stair Stringers

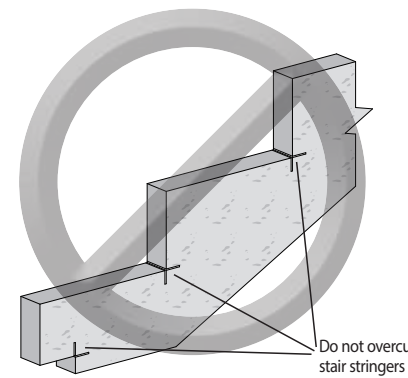

R11 DON'T Partially Support Stringers - Top

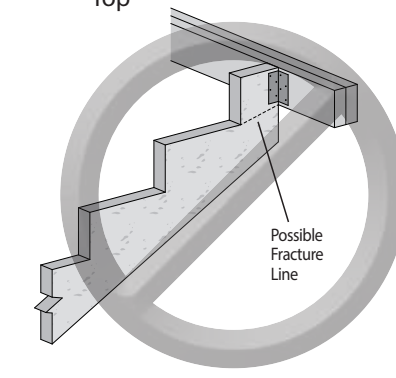

R12 DON'T Partially Support Stringers - Bottom

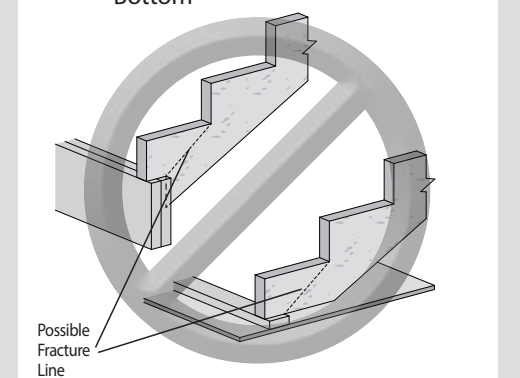

Customer Service and Product Technical Support: 1.888.820.0325

E-mail: customer.support@lpcorp.com

Visit our web site at: www.lpcorp.com

LP SolidStart Material Safety Data Sheets (MSDS) may be found on our website, www.lpcorp.com.

LP SolidStart Engineered Wood Products are manufactured at different locations in the United States and Canada. Please verify availability with the LP SolidStart Engineered Wood Products distributor in your area before specifying these products.



PEFC®
PEFC/29-31-102



SUSTAINABLE FORESTRY INITIATIVE
Good for you. Good for our forests.
www.sfi-program.org

BV-SFICOC-US09000262

© 2019 Louisiana-Pacific Corporation. All rights reserved. APA and APA Rated are registered trademarks of APA - The Engineered Wood Association. FastenMaster® and TrussLok® are trademarks of OMG, Inc., SIMPSON Strong-Tie® is a registered trademark of Simpson Strong-Tie Company, Inc., USP® is a registered trademark of MiTek Holdings, Inc., SFI and the associated logo are trademarks of Sustainable Forestry Initiative, Inc., PEFC and the associated logo are trademarks of Programme for the Endorsement of Forest Certification, LP® and SolidStart® are registered trademarks of Louisiana-Pacific Corporation. Printed in USA. Specifications (details) subject to change without notice.

NOTE: Louisiana-Pacific Corporation periodically updates and revises its product information. To verify that this version is current, contact the nearest sales office, visit LPCorp.com, or call 1-888-820-0325.