

INSTALLATION AND MAINTENANCE INSTRUCTIONS

LP ELEMENTS® PERFORMANCE FENCING (76 SERIES & 92 SERIES PRIMED PICKETS)

GENERAL INFORMATION

- Before you begin, check with the local Building Department, Zoning ordinances, Historic District regulations and Homeowners Association requirements as they may regulate the location, style and height of your fence.
- Call before you dig. Contact your local utility companies to mark any underground cables and pipelines.
- Fence permits may be required by local Building and/or Zoning Departments, Historic Districts or Homeowners Associations.
- Pickets are intended to be fastened to fence frame (post and rails) and are strictly limited to vertical installations. Reference fence frame installation instructions, local codes, and/or recommendations from the American Fence Association.
- Store pickets off the ground on a flat, well-supported, covered, and well-drained surface.
- Inspect for damage prior to installation.
- Field cut fence pickets must be painted to prevent moisture intrusion. Carefully apply two or more layers of manufacturer recommended touch-up paint until the exposed wood is completely covered. See paint specification in finishing section below.
- For the cleanest cut and longer blade life, a fine-tooth carbide tipped blade is recommended.
- Dog ear picket tops shall not be cut. Top of picket has additional paint that protects the product from the elements.
- Pickets shall not be in direct contact with brick, stone, or stucco siding; provide a 3/8 inch vertical space between picket and siding.
- Pickets shall be kept free from constant or excessive sources of moisture such as: sprinklers, storage materials placed up against fence, or landscape materials planted too close to pickets restricting natural light between them.

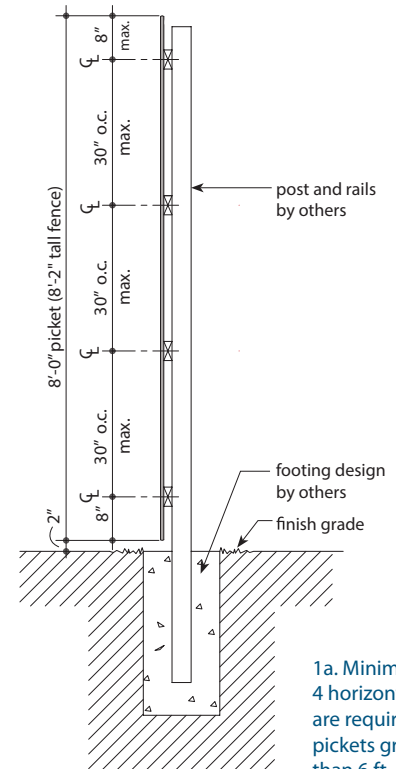

1a. Minimum of 4 horizontal rails are required for pickets greater than 6 ft. in height

INSTALLATION

- Minimum 2 inch clearance must be maintained between bottom of picket and finish grade, mulch, patios, decks, or walking surfaces.
- Do not allow mulch to be in contact with bottom of pickets.
- Horizontal rails shall be a maximum of 30 inches o.c.
- Pickets shall not extend 8 inches above or below horizontal supports centerline.
- To reduce picket length only cut picket at bottom and apply adequate layers of touch-up paint recommended by manufacturer.
- Minimum fastener size to nominal 2 x 4 horizontal rail use 0.092 inch diameter x 1-7/8 inch long, hot-dipped galvanized ring shank nail or equal (ASTM A153).
- Do not use staples to fasten pickets to fence frame.
- Refer to diagrams 1a, 1b, and 1c for details on the number of rails required for the height of your fence.

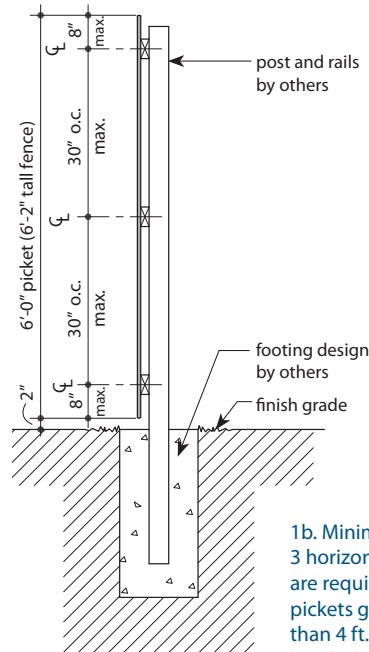

1b. Minimum of 3 horizontal rails are required for pickets greater than 4 ft. in height but 6 ft. or less in height.

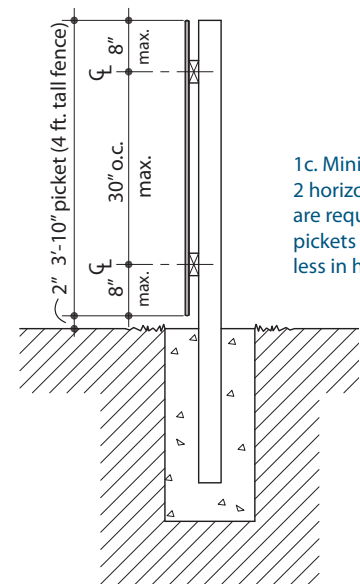

1c. Minimum of 2 horizontal rails are required for pickets 4 ft. or less in height.

- Corrosion resistance fastener must be warranted and capable of preventing rust, stain and deterioration under normal outdoor environmental conditions for a period of no less than 10 years. For further information or guidance, consult your nail supplier/ manufacturer.
- Fence post shall be spaced a maximum of 8 ft o.c. unless local building code requirements are more restrictive.
- To touch-up overdriven fasteners refer to diagram 2a.
- Place fastener approximately 1-1/2 inches from edge of picket on each side, for a total of two fasteners per picket at each horizontal rail (see diagram 2b).

Shank Diameter ≥ 0.092 "			
CONDITION		CORRECTION	
Snug		OK	
Flush		OK	
Visible Fiber		Paint	

2a

FINISHING (MUST BE PAINTED)

- Seal all exposed surfaces, including all drip edges or where water will hang.
- Apply finish coat as soon as possible or within 90 days of application.
- Follow the coating manufacturer's application and maintenance instructions.
- For best results, use exterior-quality 100% acrylic latex paint specially formulated for use on wood and engineered wood substrates; oil paint is acceptable.
 - Alkyd acrylic hybrid paint used as a primer is acceptable, not as finish coat.
 - DO NOT USE shake or shingle paint.
 - DO NOT USE semi-transparent and transparent stain.
 - DO NOT USE vinyl-based resin formulas such as vinyl acetate, PVA, vinyl acetate/acrylic copolymer paint.
- For best results, use satin finish.
- Primed pickets MUST BE PAINTED to be eligible for the limited warranty.

Recommended Nail Placement

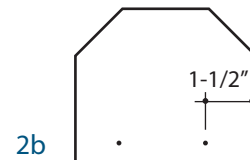

2b

CARE AND MAINTENANCE

- To clean, remove all dust and mildew from the surface by washing fence pickets with a brush and a solution of mild detergent (such as dish soap) and water. Start at the top, work your way down, and rinse from top to bottom with water. Do not use a pressure washer.
- Do not use yard maintenance equipment such as, but not limited to, edge trimmers, weed trimmers, or lawn mowers against surface of fence pickets.

LIMITED WARRANTY

The Louisiana-Pacific Corporation ("LP") LP Elements® (the "Products") limited warranty (the "Warranty") applies only to structures on which the Products have been installed, finished and maintained in accordance with the published Installation and Maintenance Instructions in effect at the time of application. Products affected by a failure to follow the Installation and Maintenance Instructions ("Affected Products") will be excluded from coverage under the Limited Warranty.

LP assumes no liability for any loss or damage caused by the Affected Products and is expressly released by the purchaser or owner from any such loss or liability.

WARRANTY REMEDIES ARE NOT AVAILABLE IF REQUIREMENTS ARE NOT FOLLOWED.

Louisiana-Pacific Corporation
414 Union St.
Nashville, TN 37219

LP Elements®
 PERFORMANCE FENCING

For complete warranty or support, visit LPCorp.com/Elements or call 800-450-6106

WARNING: Drilling, sawing, sanding or machining wood products can expose you to wood dust, a substance known to the State of California to cause cancer. Avoid inhaling wood dust or use a dust mask or other safeguards for personal protection. For more information go to www.P65Warnings.ca.gov/wood.

© 2020 Louisiana-Pacific Corporation. All rights reserved. All trademarks are owned by Louisiana-Pacific Corporation.

Patent Pending
 LPEL0088 11/2020