



BRUSHED SMOOTH OR CEDAR TEXTURE PREFINISHED NICKEL GAP SIDING

LOUISIANA-PACIFIC CORPORATION PERIODICALLY UPDATES AND REVISES ITS PRODUCT INFORMATION AND APPLICATION, CARE, AND MAINTENANCE INSTRUCTIONS. WARRANTY REMEDIES ARE NOT AVAILABLE IF THESE INSTRUCTIONS ARE NOT FOLLOWED. THE INFORMATION IN THIS DOCUMENT IS SUBJECT TO CHANGE WITHOUT NOTICE.

FIND ALL LP® SMARTSIDE® PRODUCT LITERATURE AT LPCORP.COM/PRODUCT-LITERATURE

LP® SmartSide® ExpertFinish® Trim and Siding is covered under the LP® SmartSide® Prorated 50-Year and 15-Year Limited Warranty. Refer to the warranty, which is available online, for complete terms and conditions. Product must be transported, stored, handled, installed, finished, and maintained in accordance with all published application, finishing, care, and maintenance instructions, technical notes, and bulletins (collectively, "Instructions") in effect at the time of installation.

Failure to follow such Instructions will make the limited warranty inapplicable as to the products affected by such failure. No modification or exception to these Instructions and no non-published recommendations are valid unless issued in writing on a project-specific basis by LP's Sr. Director of Technology prior to application. Always check and comply with local building codes. Even where these instructions approve installation over certain substrates or incorporate requirements of building codes, LP's liability for the performance of the product is limited as expressly provided in the Limited Warranty.

⚠ WARNING: Drilling, sawing, sanding or machining wood products can expose you to wood dust, a substance known to the State of California to cause cancer. Avoid inhaling wood dust or use a dust mask or other safeguards for personal protection. For more information go to P65Warnings.ca.gov/wood-dust.

PRODUCT LEGEND

- A LP® SmartSide® ExpertFinish® Lap Joint Siding
- B LP® SmartSide® ExpertFinish® Panel Siding
- C LP® SmartSide® ExpertFinish® Vertical Siding
- D LP® SmartSide® ExpertFinish® Cedar Shake
- E LP® SmartSide® ExpertFinish® Trim & Fascia
- F LP® SmartSide® ExpertFinish® Soffit
- G LP® SmartSide® ExpertFinish® Accessories
- H LP® SmartSide® ExpertFinish® Nickel Gap Siding

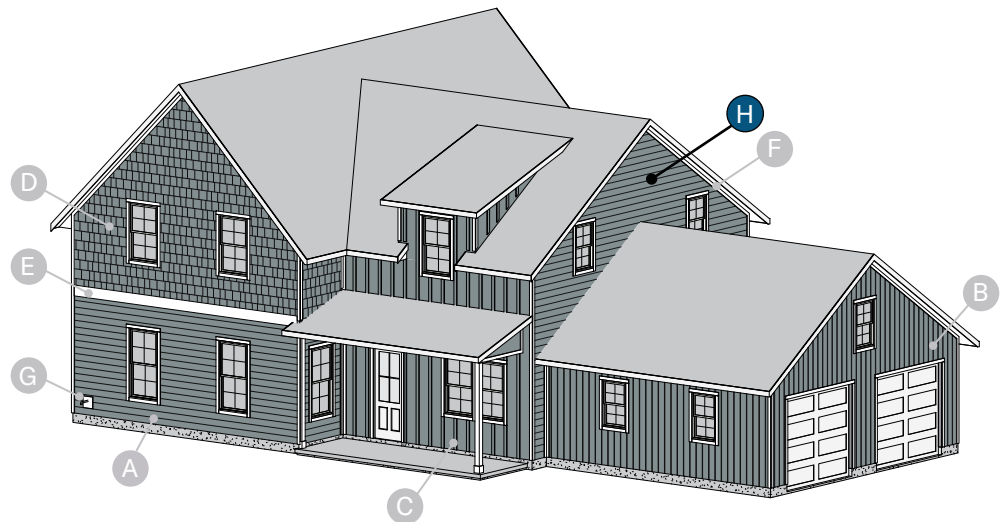

GENERAL INFORMATION

HANDLING

- Handle prefinished LP SmartSide ExpertFinish lap siding with extreme care during storage and application.
 - When unpackaging siding, cut the clear shrink-wrap the full-length of siding to avoid dragging and scuffing of the painted surface.
 - If siding is restacked after removing clear shrink-wrap, make sure to keep slip between painted surface and back of the siding.



STORAGE

- Store off the ground well supported, on a flat well-drained surface. If delivered without a pallet, additional support may be required to provide a minimum 2 inch (51 mm) clearance of Prefinished siding from the ground.
- Store Prefinished siding under a roof or separate waterproof covering until the siding is installed on the structure. **The clear shrink-wrap is perforated and does not provide protection from water intrusion.**
 - Protect the Prefinished siding at the end of each installation day by moving siding back under a roof or reapply a waterproof covering.
- Do not install if any type of residue is detected on the surface. Follow Residue Removal Guidelines in [Technical Bulletin #053](#).

GENERAL INFORMATION (CONT'D.)

BEFORE YOU BEGIN

- At the time of manufacture, siding meets or exceeds the performance standards set forth in ICC-ES AC321 and has achieved recognition under PR-N124, CCMC 11826-L and HUD-MR-1318d. For copies of product approvals go online at <https://lpcorp.com/product-literature> or call LP Customer Support at 888-820-0325.
- Where siding butts window trim, door casings, etc. or at butt joints, leave a 3/16 inch (5 mm) gap and seal.
 - A larger gap is required when siding is adjacent to stucco, brick, cultured stone, mortar, etc. (Figure 3f, 3g)
- Siding applied adjacent to surfaces such as porches, patios, balconies, or walking surfaces (including porch columns) must have a clearance of at least 1 inch (25 mm) above horizontal surface.
 - Clearance may be reduced to 3/8 inch (10 mm) for:
 - Porches, patios, balconies, or walking surfaces that slope away from the structure or the surface provides gaps that allow water to flow through so that it cannot accumulate, and is covered by a roof, not an eave or overhang; or
 - Porch columns with walking surfaces that slope away from the structure or the surface provides gaps that allow water to flow through so that it cannot accumulate.
- All wood substrate directly exposed to the weather must be sealed to prevent moisture intrusion and water build up.
 - Seal ALL exposed cuts of siding. Field spray applied coatings on cuts are not recommended.
 - Sealing can be accomplished by applying a paint or sealant according to the manufacturer's requirements.
- See **Alternate Fastening Options** starting on page 7 for Nickel Gap siding installed vertically, and page 8 for attaching Nickel Gap siding to SIP or wood structural panel (WSP) sheathing, steel studs, or Insulated Concrete Form (ICF) assemblies.

TRIM

- Use a min. 440 Series trim so the siding does not extend beyond the face of the trim.
 - If trim is installed over siding, 190 Series trim may be used.
- See page 9 for PREFERRED and ALTERNATE details for Outside and Inside Corner Trim. (Figure 9d, 9e, 9f, 9g)

FLASHING

- All openings must be properly sealed or flashed in a manner that prevents moisture intrusion or buildup.
- Flashing shall be metal or another durable material that will last for not less than 50 years.
- Install step flashing at roof-to-wall intersections with a min. 4 inch (102 mm) upper leg. (Figure 2a, 2b)
- All other flashing must have a min. 4 inch (102 mm) upper leg.
 - Add 4 inch (102 mm) wide adhesive flashing when upper leg is less than 4 inches (102 mm).
- Properly integrate flashing with WRB, use flashing tape or WRB to maintain counterflashing principle.
- LP manufactures a custom pan flashing profile intended to be used with Nickel Gap siding. Refer to pages 6 and 7 for butt joint flashing options and installation guidelines.

ROOF TO WALL INTERSECTION

- Maintain 1 inch (25 mm) clearance between siding and roofing, or trim and roofing. *[Min. 50 mm (2 inch) clearance at intersection with roof line must be maintained between roof surface and cladding when installing cladding in Canada in accordance with the NBC, Section 9.27.2.4.(2) or local building code requirements.]*

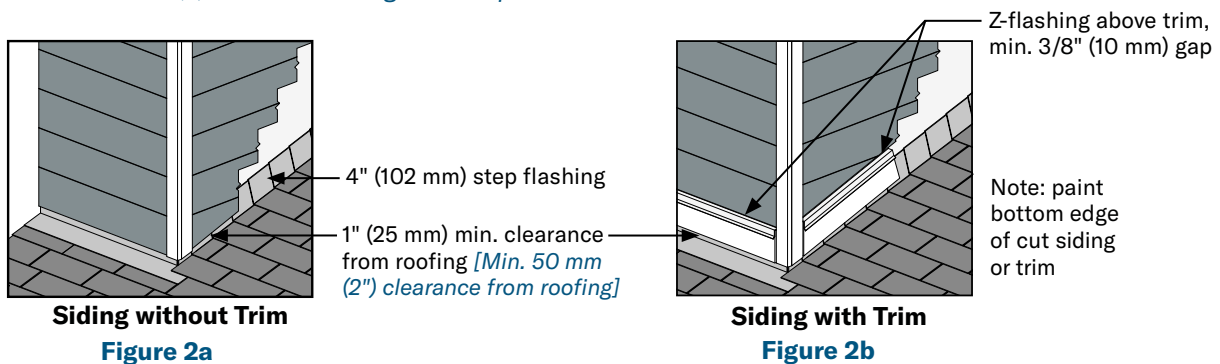

KICK-OUT FLASHING

- Install kick-out flashing at roof eave-to-wall intersections to direct water into gutter. (Figure 3a)
- **DO NOT extend siding or trim into kick-out flashing or gutter.**
- Maintain 1 inch (25 mm) clearance between the end of the gutter and the adjoining wall to allow for proper maintenance of the siding.

FLASHING

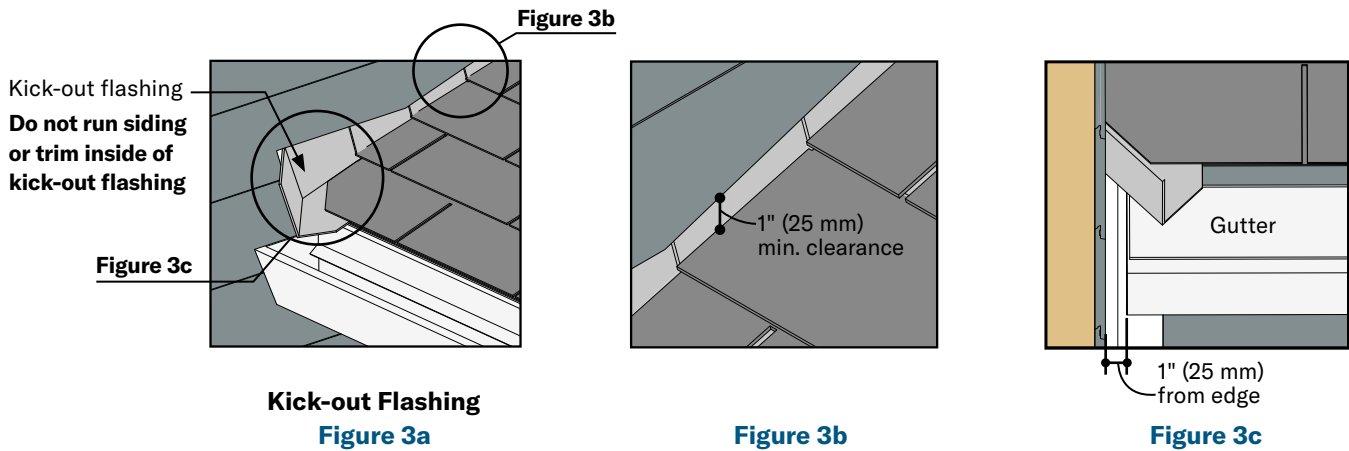

Kick-out Flashing

Figure 3a

Figure 3b

Figure 3c

MOISTURE

- Moisture and vapor control are critical elements of proper housing design.
 - Check your local building code for requirements for handling moisture and water vapor in your area.
 - Do not apply engineered wood siding to a structure having excessive moisture conditions such as drying concrete, plaster or wet blown cellulose insulation.
 - If such conditions exist, building should be well ventilated to allow to dry prior to siding application.
 - When using wet blown cellulose insulation it must not be in direct contact with the siding, and it must be allowed to dry a min. of 24 hours or longer if specified by the insulation manufacturer.
- Siding must not be installed on green or crooked studs. Green studs must be allowed to equilibrate to ambient moisture conditions before siding is installed, and siding must be shimmed to maintain flatness if studs are crooked.
- Do not apply siding over rain-soaked or buckled sheathing.

WATER-RESISTIVE BARRIER (WRB)

- A properly installed WRB is required behind siding, unless exempt by building code.
- LP assumes no liability for water penetration or any other issues associated with the WRB.

CLEARANCE & SEPARATION GUIDELINES

- Min. 6 inch (152 mm) clearance must be maintained between siding and finish grade (ground cover). *[Min. 200 mm (8 inch) clearance must be maintained between cladding and finish ground when installing cladding in Canada in accordance with NBC, Section 9.27.2.4.(1) or local building code requirements.]*
- Provide separation between back of siding and concrete or masonry foundation. Separation can be achieved using a WRB, flashing, or similar product. (Figures 3d, 3e, 3f)

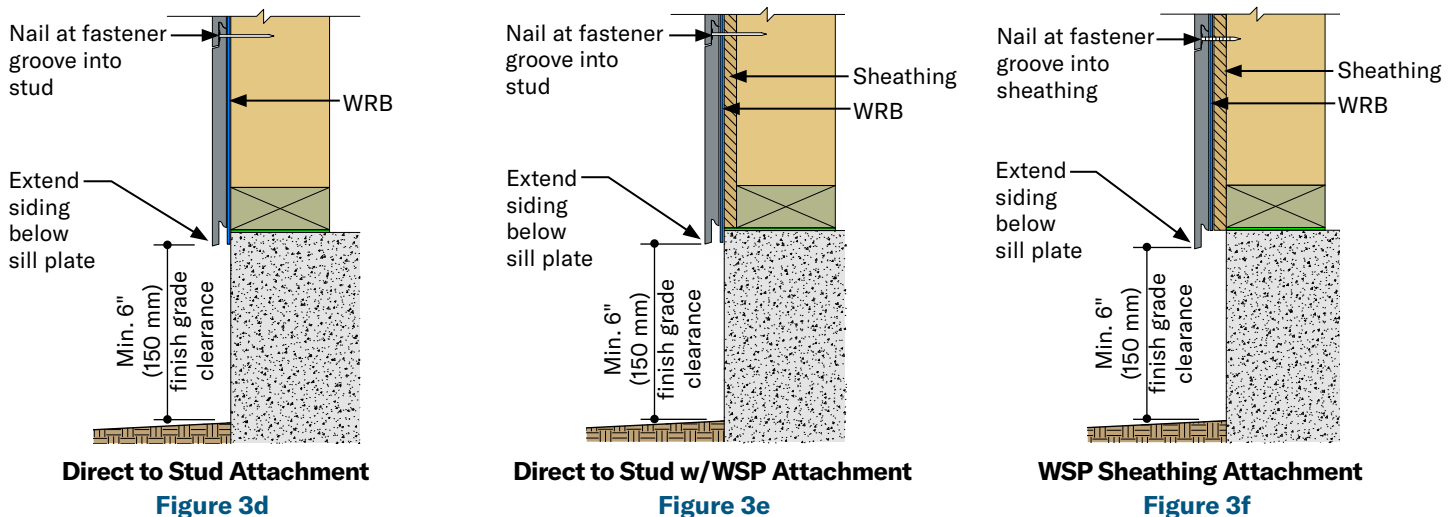

Direct to Stud Attachment

Figure 3d

Direct to Stud w/WSP Attachment

Figure 3e

WSP Sheathing Attachment

Figure 3f

TRIM OR SIDING ADJACENT TO STUCCO/MASONRY

- Do not install trim or siding horizontally to create ledge or window sill. (Fig. 4a)
- Where siding is installed directly adjacent to stucco, brick, cultured stone, mortar, etc., leave a min. 3/8 inch (10 mm) gap and caulk, backer rod recommended. (Figure 4b, 4c, 4d)

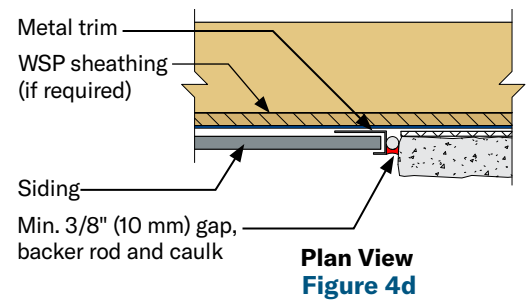
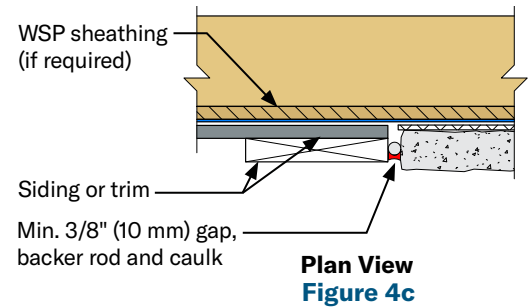
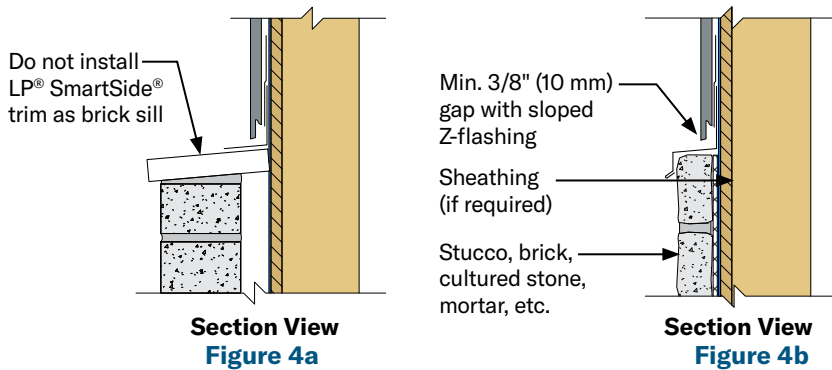

FINISHING INSTRUCTIONS

- When caulk is required, use a high-quality, non-hardening, paintable sealant meeting ASTM C920, minimum Class 25.
 - Follow sealant manufacturer's instructions for application.
- Paint all exposed surfaces, including all drip edges or where water will hang. For best results, use a high-quality 100% acrylic exterior paint specially formulated for use on wood and engineered wood substrates; oil paint is acceptable.
 - DO NOT USE stain or vinyl-based paint.
 - Apply paint as soon as possible or within 180 days.
 - Follow paint manufacturer's instructions for application.
 - Follow LP's Care & Maintenance Instructions.

BRUSHED SMOOTH Lap Joint Siding:

- Either flat, satin or semi-gloss coatings can be applied to brushed smooth finish lap siding.
 - Each offers different appearance & maintenance benefits.

CEDAR TEXTURE Lap Joint Siding:

- For best results use semi-gloss finish.
- Touch up any damage to finish that may occur during application
- Apply touch up paint to cover scratches less than 1 inch (25 mm) in length and less than 1/16 inch (2 mm) wide, exposed nail heads and small nicks.
- Do not apply touch up paint to spots greater than 3/4 inch (19 mm) in diameter.
- Touch up paint should be used sparingly.
 - Apply touch up paint only when air, siding and paint temperature are above 50°F.
 - Store touch up paint between 40°F and 100°F.
 - Shake touch up paint for 90 seconds before every use.
 - Do not use touch up paint if you suspect it has frozen.
 - Do not apply touch up paint to wet siding.
 - Avoid touch up painting when condensation likely to form.
 - Avoid touch up painting when precipitation is possible.
- The touch up paint is air dried, while the factory applied coating is cured using ovens. For this reason, the touch up paint will have some minor differences initially and after time. Minimizing the use of touch up paint is the best approach to help ensure these minor differences are less noticeable.
- Use the appropriate applicator provided in the LP® SmartSide® ExpertFinish® Touch-Up Kit.
 - Nail Head Paint Applicator (Figure 4e)
 - Cut End Paint Applicator (Figure 4f)
- For additional touch-up paint, please call 888-820-0325.



Figure 4e



Figure 4f

FASTENING INSTRUCTIONS

STUD SPACING OPTIONS

- Siding may be attached **direct to studs** spaced max. 24 inches (610 mm) o.c.
- Siding may be attached **directly to a min. 7/16 Category wood structural panel (WSP) sheathing** with studs spaced a max. 24 inches (610 mm) o.c. (Figure 9c, 9d)

INSTALLATION

- Provide separation of Nickel Gap siding from CMU or poured concrete foundation. (Figures 3d, 3e, 3f)
 - Separation should be achieved by ensuring WRB is placed behind siding.
 - A starter strip is not required.
- Install siding blind-nailed, place nail in fastener groove. (Figure 5a)
 - Stack successive courses.
 - The following tools may be used to assist in obtaining desired gap when stacking pieces:
 - Pull bar typically used to install wood flooring, can be used to pull siding together to achieve desired horizontal gap. (Figure 5b)
 - Create blocking by cutting a section of Nickel Gap siding. Remove top nailing flange to create a flat surface. Rest blocking on top flange and **firmly tap** siding into place. (Figure 5c)
 - 2x wood stud, approx. 16 inches (406 mm) long. Rest blocking on top flange and **firmly tap** siding into place. (Figure 5c)
 - Desired gap can range between 1/16 inch (2 mm) and 1/8 inch (3 mm). Use a 0.092 inch or 0.113 inch diameter nail to verify desired gap is achieved.
 - Do not damage** top nailing flange when using these tools.
- Nail from the center of the siding toward the ends, or from one end to the other end. NEVER nail from the ends of the siding toward the middle.
- Use a min. 0.092 inch shank diameter, hot-dip galvanized nail (ASTM A153, Class D) or equivalent; capable of preventing rust, stain and deterioration under normal outdoor environmental conditions for a period of no less than 50 years. Penetrate studs or combination of WSP sheathing and studs a min. of 1-1/2 inches (38 mm).
 - A larger 0.113 inch shank diameter nail may be required depending on the wind pressure, wind speed and wind exposure category limitations in [PR-N124](#). Penetrate studs or combination of WSP sheathing and studs a min. of 2 inches (51 mm).
- Butt joints should be staggered over successive courses.
- Top flange must be ripped at top of wall where siding meets soffit or frieze board. (Figure 5d)
- Do not overdrive nails. (Figure 5e)
 - Nail head should seat snug in fastener groove, but not countersunk which is considered overdriven.
 - Blind nails:** only correction required would be re-nailing when countersunk more than 1/8 inch. (Figure 5f)
 - Face nails:** will occur immediately below window sills, soffit, frieze boards, and horizontal trim. Corrections are detailed in Figure 5g.
- Painting all exposed nail heads is recommended.

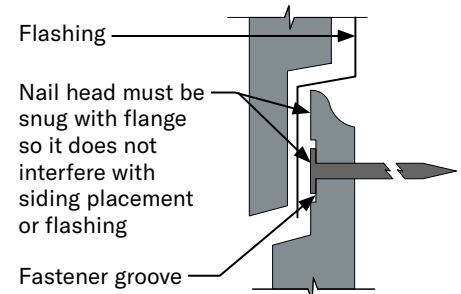
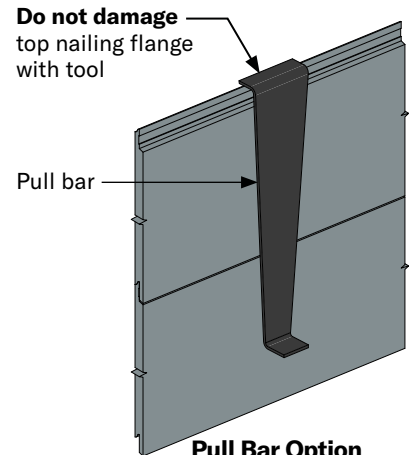
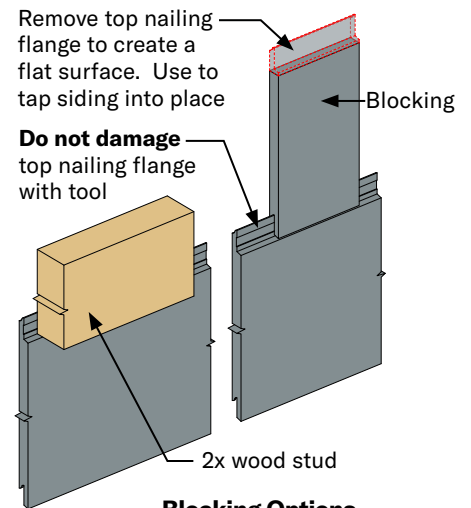

Figure 5a



Pull Bar Option
Figure 5b



Blocking Options
Figure 5c

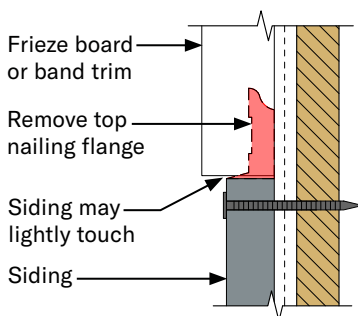
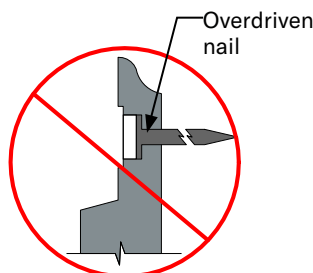
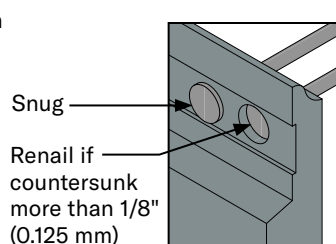

Figure 5d



INCORRECT
Figure 5e



BLIND NAILED
CONDITION
Figure 5f

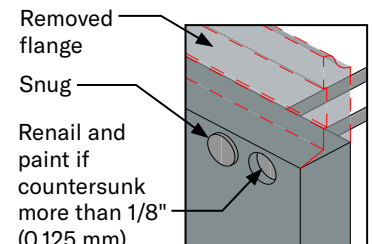

FACE NAILED
CONDITION
Figure 5g

BUTT JOINTS

- Siding has been manufactured to remove a section of the flange located on the back of siding to accommodate flashing at the butt joint. Ensure this feature and factory prefinished ends are maintained on both sides of the butt joint. (Figure 6e)
- Butt joints must occur over studs. (Figure 6a)
 - Exception: sheathing only applications.
- Stagger butt joints a min. of 16 inches (406 mm).
 - Stacking or stair-stepping butt joints is not recommended as it may cause an undesirable appearance.
- **Provide a min. 3/16 inch (5 mm) gap at butt joint.** (Figure 6a)
 - Use spacing tool like SIMPLESIDER® siding gauge (Figure 6b) or rafter square (Figure 6c) to achieve proper gapping.
 - Rafter square thickness varies between manufacturers, confirm min. 3/16 inch (5 mm) thickness is provided.
 - Gapping will allow for linear expansion of siding.
 - Caulk is not required.
- LP recommends applying a min. 1 inch (25 mm) wide strip of matching paint down the center of flashing prior to installation of flashing, or use a paint brush to manually apply a coating of paint to flashing after it has been installed to help ensure complete paint coverage is worked into the butt joint. (Figure 6d)
 - Painting flashing helps to create a more consistent finished appearance but is not required.

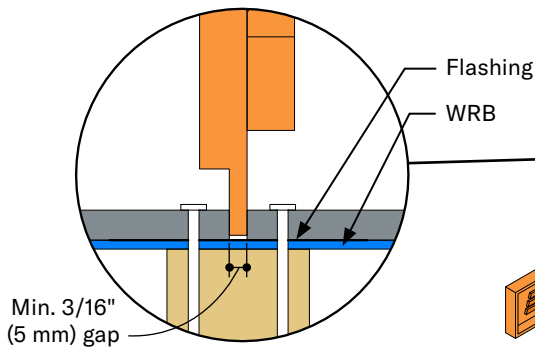

Use SIMPLESIDER® or rafter square as spacing tool to achieve min. 3/16" (5 mm) gap

Butt Joint
Figure 6a

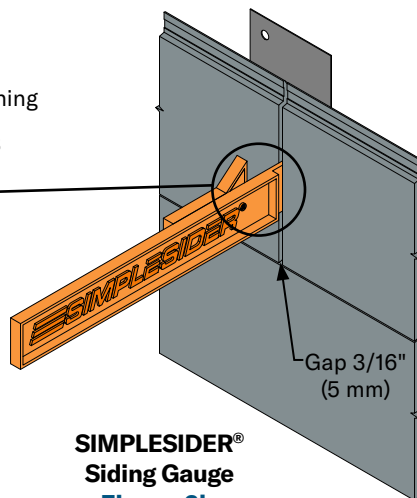

SIMPLESIDER®
Siding Gauge
Figure 6b

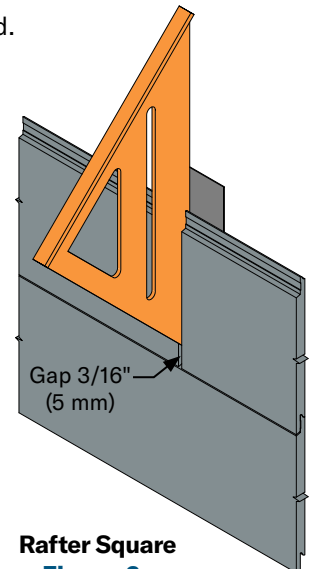

Rafter Square
Figure 6c

- Flashing butt joints can be accomplished by using one of three options:

1. LP SmartFlash metal flashing is specifically manufactured to integrate with Nickel Gap siding. (Figure 6d)

- A min. 3 inch (76 mm) section of the flange located on back of siding has been removed to receive flashing. (Figure 6e)

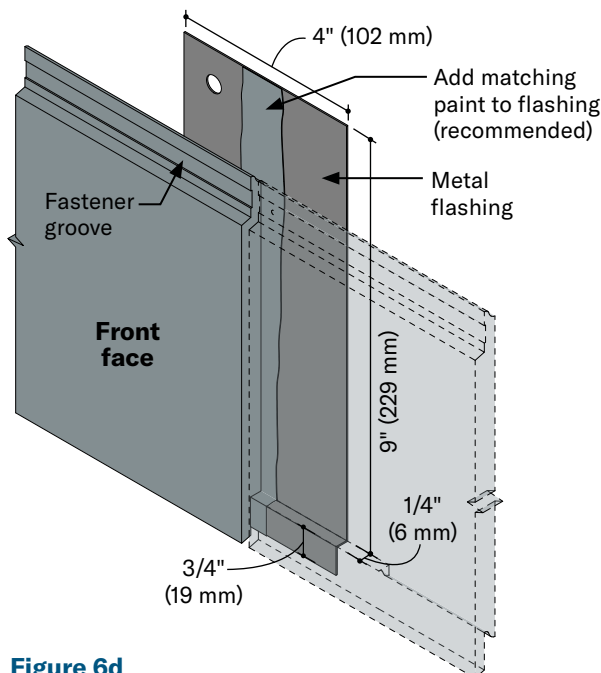

Figure 6d

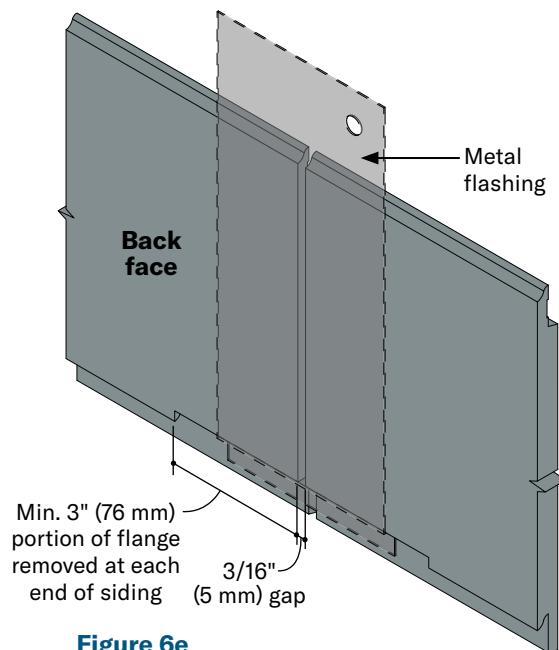

Figure 6e

BUTT JOINTS (CONT'D.)

2. Field fabricated metal flashing.

- Ensure nail head is snug to the face of the fastener groove so it does not interfere with installing the flashing.
- Ensure flashing does not restrict vertical movement at the nailing flange and does not interfere with the siding to properly stack or lay flat.
- Vertical leg of flashing is long enough to cover nail head and does not extend to the bottom of the nailing flange. (Figure 7a)

3. Non-metal flexible flashing sheet.

- Non-metal flexible flashing sheets must conform to nailing flange, shall not prevent siding from properly stacking, laying flat or provide proper drainage. (Figure 7b)
- May use non-metal flexible flashing sheet such as Bear Skin flashing sheets.

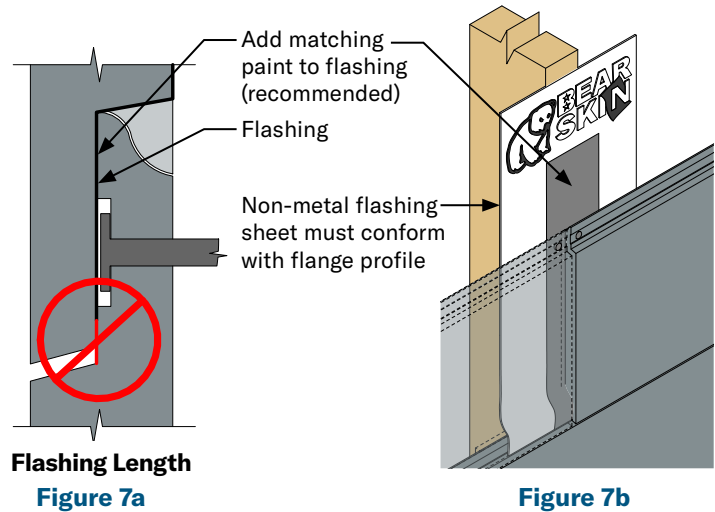

Flashing Length
Figure 7a

Figure 7b

FASTENING OPTIONS OVER FOAM PLASTIC SHEATHING (RIGID FOAM INSULATION)

- Nickel Gap siding may be installed vertically or horizontally directly over foam sheathing.

FOAM PLASTIC SHEATHING ≤ 1 INCH (25 MM)

- Increase nail length to ensure the required min. penetration into studs (Figure 7c), or combination of studs and WSP sheathing; or nail length long enough to fully penetrate sheathing a min. 1/4 inch (6 mm) for a sheathing only attachment. (Figure 7d)

FOAM PLASTIC SHEATHING > 1 INCH (25 MM)

- Siding attachment: Refer to IRC Chapter 7, Wall Covering for prescriptive siding attachments over foam sheathing up to 4 inches (102 mm) thick, direct to wood or steel studs for support of siding weight only.

Does NOT include wind loads.

- Refer to Table 703.15.1 for min. fastening requirements over foam sheathing to wood studs.
- Refer to Table 703.16.1 for min. fastening requirements over foam sheathing to steel studs.
- Fastener placement:
 - Nail spacing depends on siding attachment method;
 - Direct to Stud or WSP sheathing attachment, and
 - Wind load limitations in [PR-N124](#) or [ESR-1301](#).
- LP assumes no liability for loss or damage associated with fastening requirements of the applicable code.

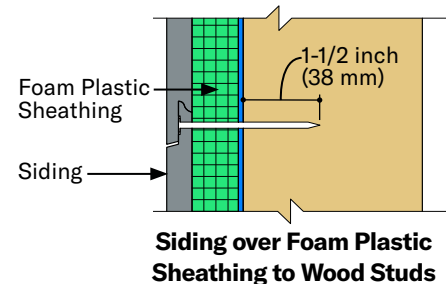

Figure 7c

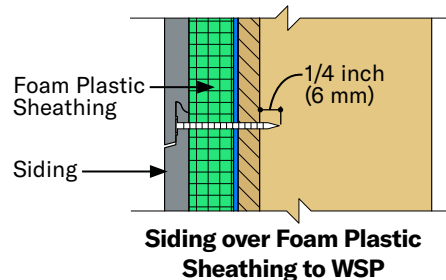

Figure 7d

ADDITIONAL FASTENING OPTIONS

EXTERIOR GYPSUM SHEATHING

- Siding may be installed over a max. 1 inch (25 mm) exterior gypsum sheathing, according to the following:
 - Adequate bracing of the wall is provided in accordance with the local building code.
 - Nail length must be increased to ensure a min. 1-1/2 inch (38 mm) penetration into wood studs, or combination of WSP sheathing and wood studs.

EXISTING WOOD SIDING OR WOOD COMPOSITE SIDING

- Siding may be installed over existing wood or wood composite siding, if the existing siding does not affect the ability to correctly install siding.
 - A properly installed WRB is required between the existing siding and the new siding.
 - A uniform surface behind siding is required to avoid contouring of siding.
 - Do not install over existing siding that is not flat or uniform; for example over lap or clapboard siding.
 - Min. nail penetration and max. stud spacing must not be compromised.
 - Ensure wall assembly meets structural requirements specified in building code and by local code authority.
 - Repair any areas of the existing siding that are not structurally sound, not installed correctly, or exhibit signs of decay.

FIRE-RATING

FIRE-RATED WALL ASSEMBLY

- LP SmartSide Nickel Gap lap siding may be installed over the exterior portion of a 1-hour fire-resistive exterior wall assembly, including assemblies using gypsum wallboard listed in the Gypsum Association Fire Resistance Design Manual.
- For information on fire-rated wall assemblies: <https://lpcorp.com/products/panels-sheathing/fire-rated-osb-sheathing/assemblies>

ALTERNATE FASTENING OPTIONS

NICKEL GAP SIDING INSTALLED VERTICALLY

- Siding must be installed in a sheathing only attachment method over min. 7/16 Category WSP sheathing with an APA Trademark that contains the consensus Standard Doc PS 1 or DOC PS 2. *[In Canada in accordance with CSA O437.0]*
 - Exception: can be installed over LP® FlameBlock® Fire-Rated Sheathing.
- Remove bottom nailing flange when installing siding next to trim. (Figure 8a)
 - Removing top nailing flange is not required.
 - Do not nail through top flange.
- The following tools may be used to assist in obtaining desired gap:
 - Pull bar typically used to install wood flooring, can be used to pull siding together to achieve desired vertical gap. (Figure 8b)
 - Create blocking by cutting a section of Nickel Gap siding. Remove top nailing flange to create a flat surface. Rest blocking on top flange and **firmly tap** siding into place. (Figure 8c)
 - 2x wood stud, approx. 16 inches (406 mm) long. Rest blocking on top flange and **firmly tap** siding into place. (Figure 8c)
 - **Do not damage** top nailing flange when using these tools.
- Siding nail requirements:
 - Use a min. 0.092 inch diameter **ring shank**, hot-dip galvanized nail (ASTM A153, Class D) or equivalent.
 - Nail shall be long enough to fully penetrate WSP sheathing by at least 1/4 inch (6 mm). Ensure that the ring shanks of the nail fully engage the WSP sheathing.
 - **Caution:** nail length should be chosen to reduce possible damage to wiring or utilities in wall.
 - Place nails max. 24 inches (610 mm) o.c. along fastener groove. (Figure 8d)
- Due to expected plate shrinkage, each vertical application of Nickel Gap is not to span beyond one floor to ceiling distance, or one floor to top of gable distance. (Figures 9a)
 - Exception: re-siding existing structures.

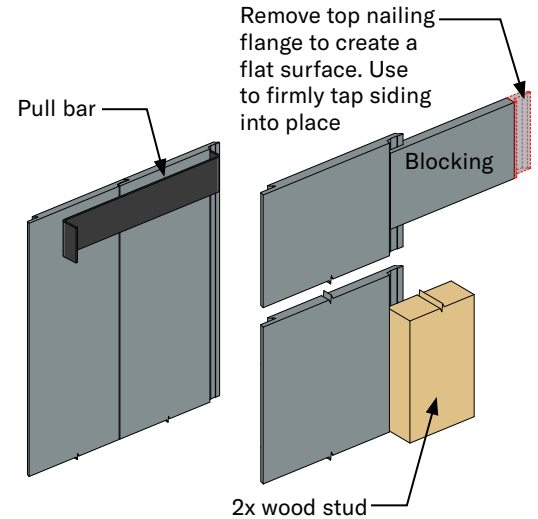

Pull Bar Option
Figure 8b

Blocking Options
Figure 8c

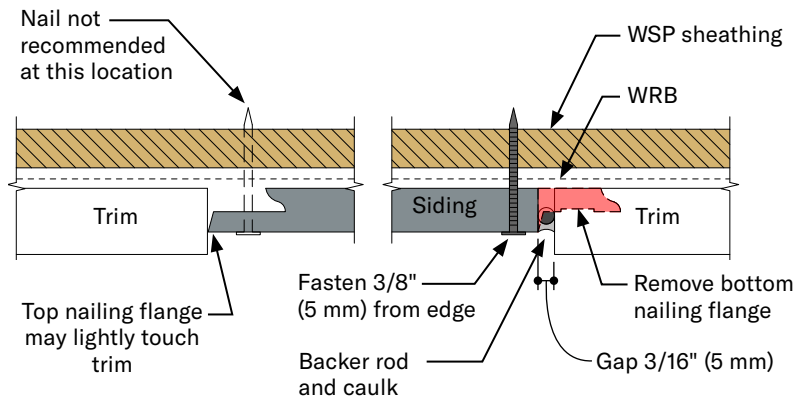

Figure 8a

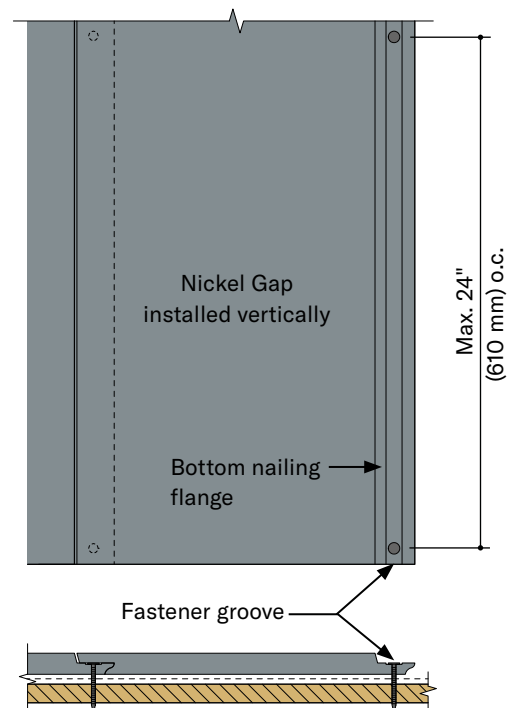

Figure 8d

NICKEL GAP SIDING INSTALLED VERTICALLY (CONT'D.)

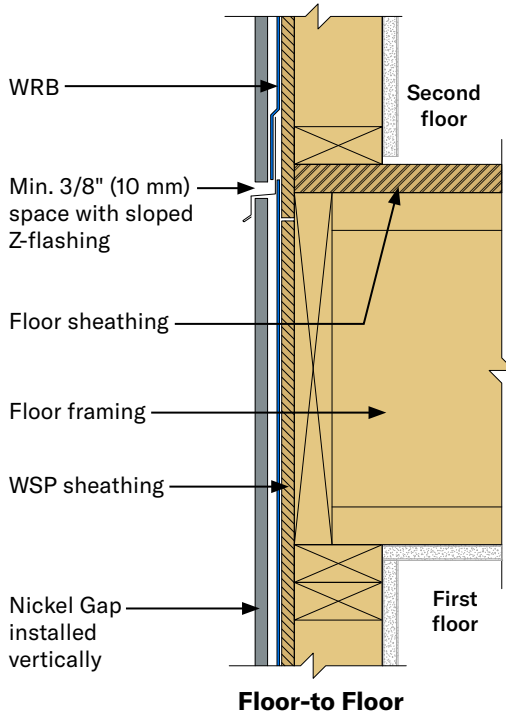

Figure 9a

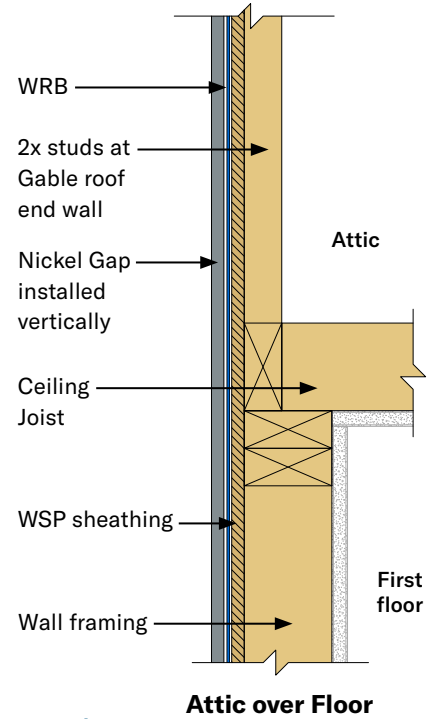

Figure 9b

NICKEL GAP SIDING INSTALLED HORIZONTALLY TO WOOD STRUCTURAL PANEL (WSP) SHEATHING OR SIP ASSEMBLIES

- WSP wall sheathing must be a min. 7/16 Category with APA Trademark stamp that contains the consensus Standard DOC PS 1 or DOC PS 2. *[In Canada in accordance with CSA O437.0]*
- Siding may be nailed to SIP or WSP sheathing with:
 - Min. 0.092 inch diameter **ring shank**, hot-dip galvanized nail (ASTM A153, Class D) or equivalent.
 - o Nail length must be long enough to fully penetrate sheathing by at least 1/4 inch (6 mm). (Figures 9c, 9d)
 - o Ensure that the ring shanks of the nail fully engage the wood structural panel sheathing.
 - Space fasteners depending on the wind pressure, wind speed and wind exposure category limitations in PR-N124, Table 4a or 4b; or ESR-1301, Table 4a or 4b.

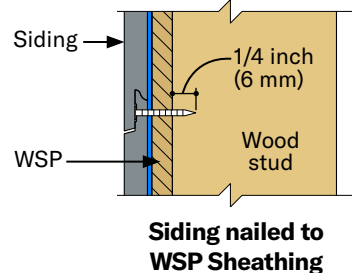

Figure 9c

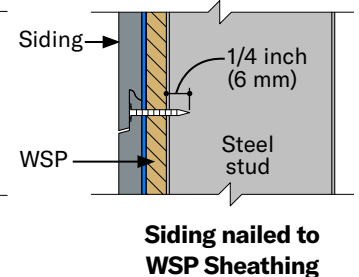

Figure 9d

STEEL STUD FRAMING ASSEMBLIES

- Siding must be fastened with:
 - Min. #8 stainless steel or equivalent, self-drilling tapered head screw.
 - Min. of 5 threads beyond the combined thickness of the siding and steel stud framing. (Figures 9e, 9f)
- Min. steel stud thickness of 0.032 inch or 20 gauge.
- Min. withdrawal value of steel stud must be 50 lbs. (23 kg).
 - Refer to steel stud manufacturer's evaluation report.

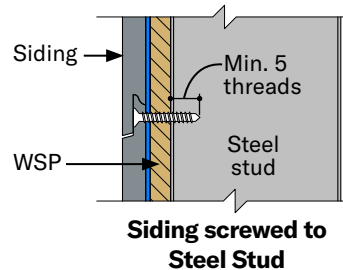

Figure 9e

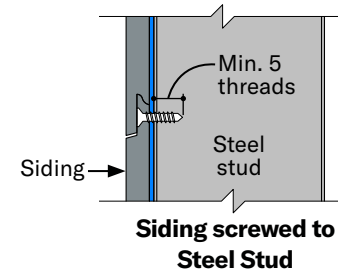
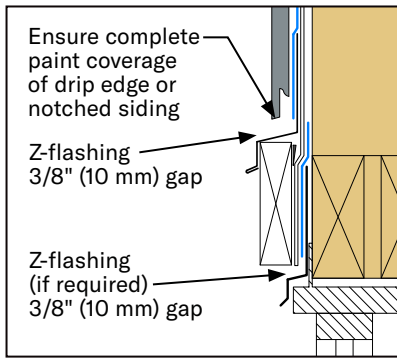

Figure 9f

INSULATED CONCRETE FORMS (ICF) ASSEMBLIES

- Web flange must be wide enough to accommodate fastener spacing requirement at butt joint.
- Siding must be fastened with:
 - Min. #8 stainless steel or equivalent, self-drilling tapered head screw.
 - Min. penetration of 3/8 inch (10 mm) beyond the thickness of the nailing flange.
- Larger screws may be required by ICF Manufacturer based on the following min. withdrawal requirements.
 - Min. withdrawal value of ICF nailing flange must be 50 lbs. (23 kg) with max. 12 inches (305 mm) o.c. spacing.
 - Min. withdrawal value of ICF nailing flange must be 31 lbs. (14 kg) with max. 6 inches (152 mm) o.c. spacing.

GENERAL INFORMATION



**Z-FLASHING OVER
DOOR & WINDOW OPENINGS
PREFERRED**
Figure 10a

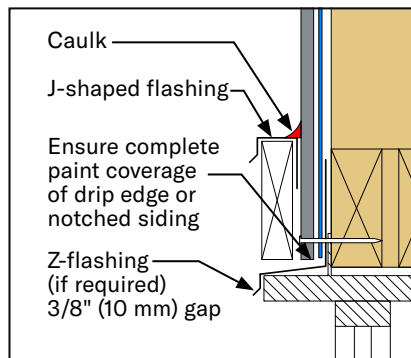

**J-SHAPED FLASHING OVER
DOOR & WINDOW OPENINGS
ALTERNATE**
Figure 10b

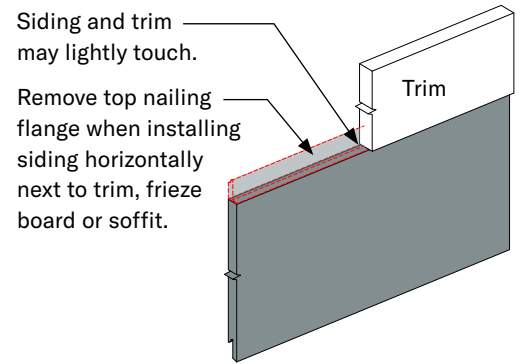

**SIDING INSTALLED
HORIZONTALLY**
Figure 10c

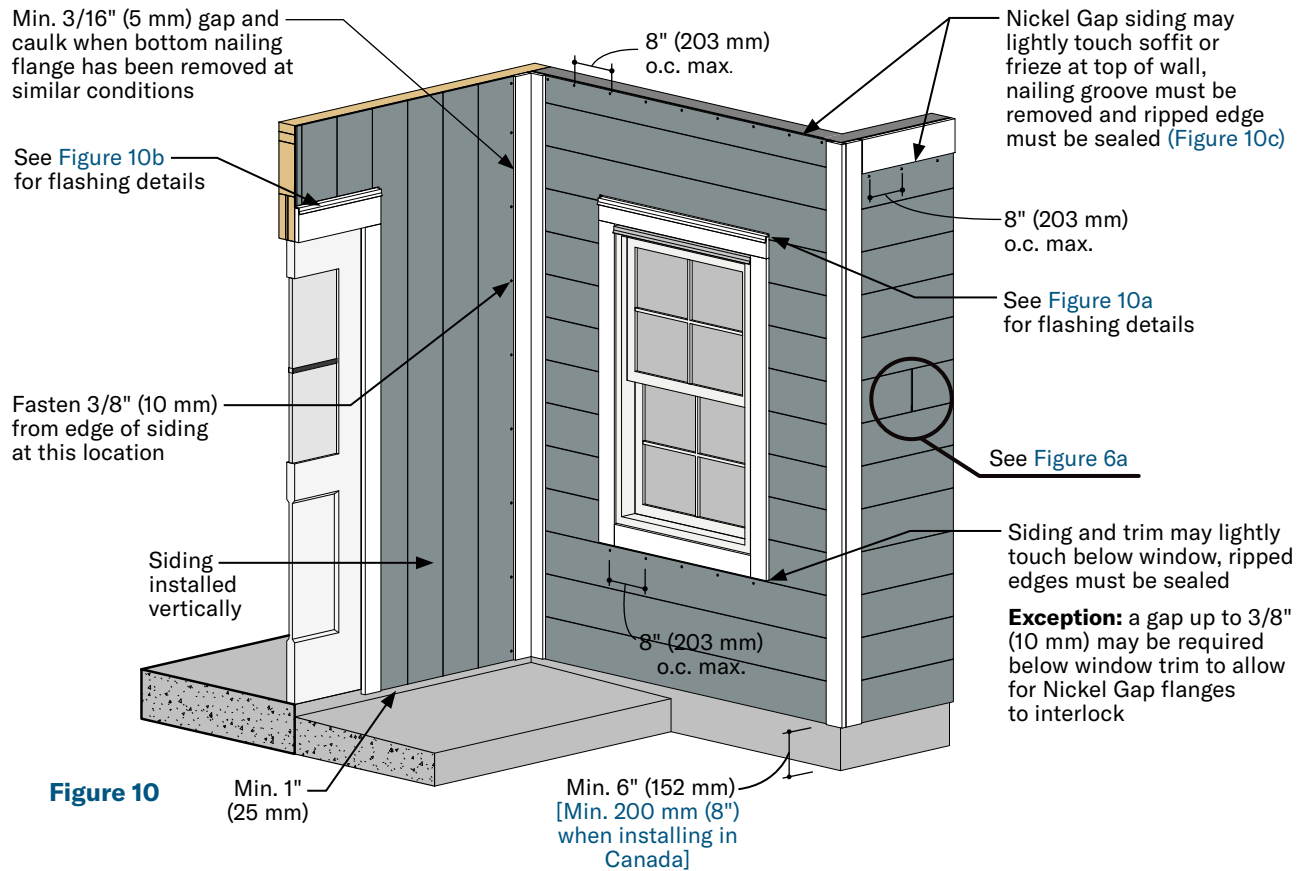
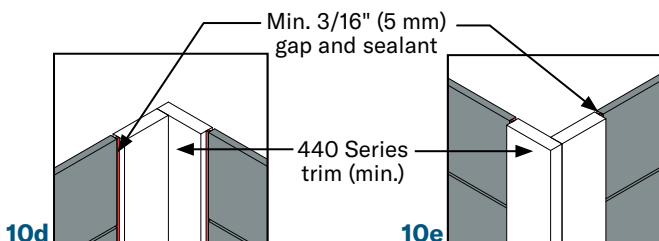

Figure 10



**INSIDE CORNER
PREFERRED**

10e

**OUTSIDE CORNER
PREFERRED**

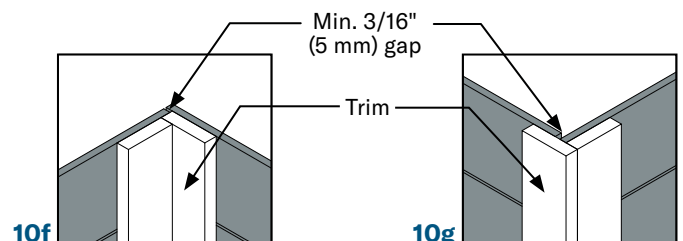

10f

**INSIDE CORNER
ALTERNATE**

10g

**OUTSIDE CORNER
ALTERNATE**

WOOD FRAMED WALL ASSEMBLIES - EXAMPLES

- WRB location in wall assembly may vary depending on climate zone or other factors.

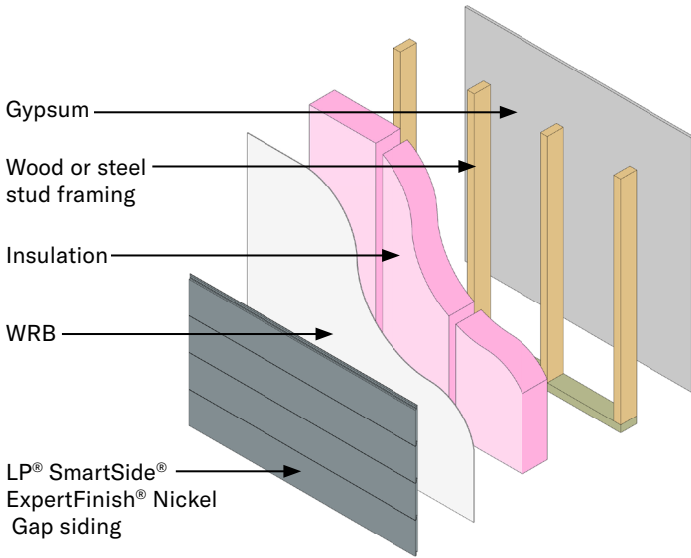

Siding without Sheathing

Figure 11a

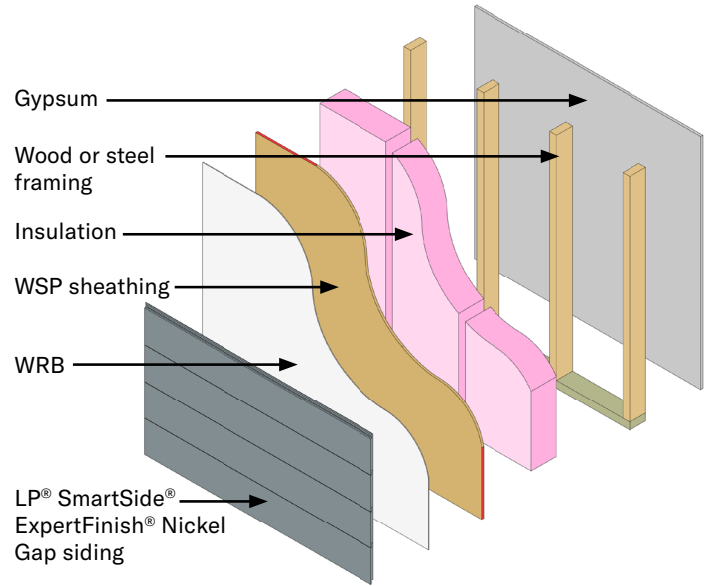

Siding with WSP Sheathing

Figure 11b

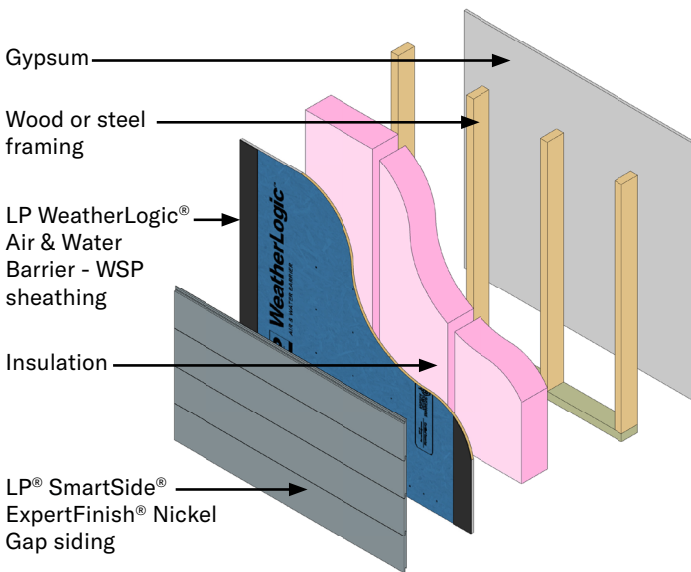

Siding with LP® WeatherLogic®

Figure 11c

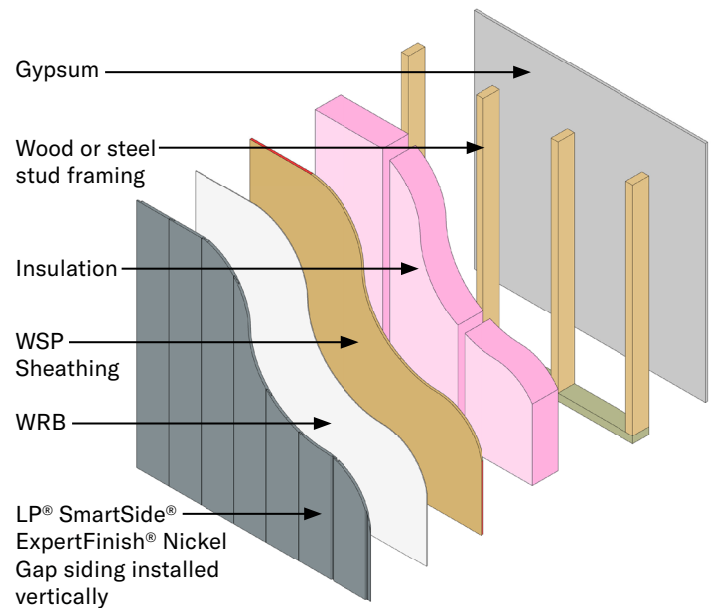

Siding Installed Vertically Directly to WSP Sheathing

Figure 11a

LP® SmartSide® ExpertFinish® Nickel Gap Siding

Application Tips

IMPORTANT Always refer to the complete application instructions for the product you are installing. The application tips provided below are not intended to replace such instructions. Application instructions can be found at LPCorp.com. Failure to follow the full application instructions could cause personal injury or property damage, affect system performance, void any applicable warranty and/or violate applicable building codes.

Exercise safe practices at all times while handling and using this product. Refer to the relevant Safety Data Sheet (SDS) for important information on the safe handling and use of this product. These can be found at LPCorp.com.

Nickel Gap siding may be attached Direct to Studs or Direct to Wood Structural Panel (WSP) Sheathing:

- **Direct to Stud** - nails must penetrate structural framing, or combination of WSP and structural framing min. 1-1/2" (38 mm), some installations may require 2" (51 mm) penetration see [PR-N124](#) or [ESR-1301](#)
- **Direct to WSP Sheathing - ring shank** nails must be long enough to penetrate beyond WSP by 1/4" (6 mm)

Stud spacing – siding may be attached **direct to studs** spaced max. 24 inches (610 mm) o.c.

See application instructions for alternative nailing options for: Nickel Gap siding installed vertically, SIP assemblies or WSP sheathing, steel studs and ICF assemblies

Nail size:

- **Direct to Stud** – a min. 0.092" shank diameter hot-dip galvanized (ASTM A153, Class D) nail may be used, some installations may require a larger 0.113" shank diameter depending on wind pressure, wind speed and wind exposure limitations in PR-N124
- **Direct to WSP Sheathing** - a min. 0.092" shank diameter hot-dip galvanized (ASTM A153, Class D) **ring shank** nail

Nail length - see page 4 in Application Instructions

Nail placement – place nail in center of fastener groove

Nail head must be snug with flange so it doesn't interfere with ability to stack siding or properly integrating pan flashing

Nail spacing:

- **Direct to Stud** – one nail every 16" (406 mm) o.c.
- **Direct to WSP Sheathing** – nailing pattern varies from 8" (203 mm) o.c. to 24" (610 mm) o.c. depending on the wind pressure, wind speed and wind exposure limitations in PR-N124 or ESR-1301

Where siding butts up against a window or door frame, or corner trim – space min. 3/16" (5 mm)

Do not overdrive nails – nail head should seat snug to the face of siding or fastener groove, if overdriven - see Application Instructions

Caulk – use a high-quality, non-hardening, paintable exterior sealant meeting ASTM C920, min. Class 25

Seal all exposed substrate – sealing can be accomplished by applying a paint or caulk

Spacing at butt joints and trim – min. 3/16" (5 mm)

Butt joints – 3 methods (add matching ExpertFinish paint color to flashing to help ensure a more consistent appearance):

1. LP SmartFlash Pan flashing
2. Field fabricated metal flashing
3. Non-metal flexible flashing sheet, such as Bear Skin flashing sheets

Siding clearance at finish grade (ground cover) – min. 6" (152 mm) *[Min. 200 mm (8 inch) when installing in Canada]*

Siding clearance adjacent to surfaces such as porches, patios, or porch columns, etc. – min. 1" (25 mm):

- May be reduced to 3/8" (10 mm) – see Application Instructions

Siding must not be in direct contact with CMU, poured concrete, brick, cultured stone, stucco, mortar, etc.

Flashing is required above all windows, doors and horizontal trim per manufacturer's instructions:

- Flashing shall be metal or another durable material that will last for not less than 50 years
- Provide 3/8" (10 mm) gap above any drip cap flashing, **do not caulk gap**

Siding below windowsill, soffit, horizontal trim or frieze board will require face-nailing - see Application Instructions

Siding over foam plastic sheathing adds complexity to siding installation – see Application Instructions

For Limitations of Use – see Application Instructions, Technical Notes, Technical Bulletins and NSA Bulletins