

Marino\WARE® Product Submittal Data

PRODUCT NAME: Deflection Drift Angle (DDA-1)

*Manufactured by CEMCO, distributed by Marino\WARE

PROPERTIES:

Size (in.)	Length (ft)	Mils (gauge)
5/8 x 1-1/4	10	18 (25)

PRODUCT:

DDA is a composite steel angle with factory applied intumescent tape to the inside leg of the angle. The DDA-1 is a fire-rated accessory when combined with Slotted Track, and offers unencumbered movement at the head-of-wall (HOW) joint in accordance with UL-2079. The 1-1/4" long leg is manufactured from red steel and labeled for proper identification. DDA-1 provides up to 1" overall dynamic movement.

FIRE RATED DESIGNS (UL 2079):

HW-D-0514; HW-D-0515; HW-D-0518; HW-D-0524; HW-D-0550;
HW-D-0551; HW-D-0553; HW-D-0554; HW-D-0556; HW-D-0573;
HW-D-0585; HW-D-0598; HW-D-0620; HW-D-0622; HW-D-0623
HW-D-0652; HW-D-0653; BW-S-0041; WW-S-0061

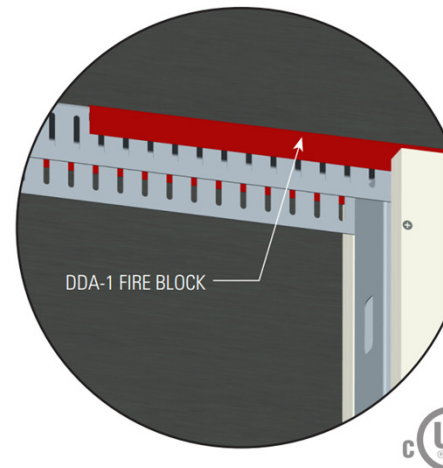
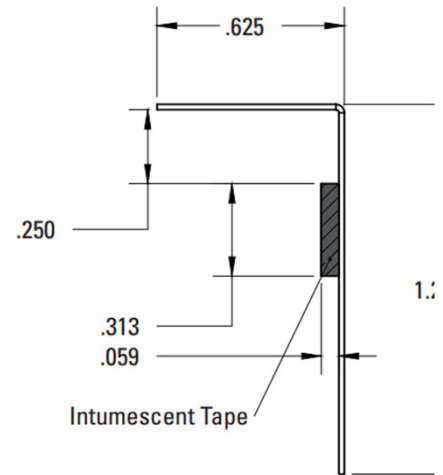

CODES & STANDARDS

- ASTM E1966 - Standard Test Methods of Fire Tests of Fire Stop Systems.
- ASTM E119 - Standard Test Methods for Fire Tests of Building Construction and Material.
- ASTM E90 - Sound testing, up to STC 66
- ASTM A653, C645, A1003 & A924
- Air Leakage Tests for compliance to Section 713.6 of the IBC.
- UL 2079 5th Edition
- IBC 2015

U.S. Patent 8,595,999



www.marinoware.com

For more information, please contact Marino\WARE Technical Services at 866-545-1545.

This technical information reflects the most current information available and supersedes any and all publications, effective 1/10/2018
©Copyright 2018 by Ware Industries, Inc. All rights reserved