



Geometric Properties

FAS J-Track has longer legs than standard J-Runner to provide greater deflection at the head-of-wall joint. FAS J-Track provides 3/4" overall unencumbered movement providing the best possible L-Rating (smoke) for 1 and 2 hour fire ratings. FAS J-Track also eliminates the installation of fire caulking of additional drywall ribs. FAS J-Track is manufactured in 33mil thick G40 hot-dipped galvanized steel. G60 and G90 are available only upon special request and will require extended lead-times.

Steel Thickness

Thickness (mil.)	Design Thickness (in.) ¹	Minimum Thickness (in.) ^{1,2}	Yield (KSI)	Web Sizes (in.)(A)	Leg Sizes (in.)
33	0.0346	0.0329	33	2-1/2, 4, 6	1-1/2 & 2-1/2

Notes:

- 1. Uncoated steel thickness. Thickness is for carbon steel.
- 2. Minimum Thickness represents 95% of the design thickness and is the minimum acceptable thickness delivered to the job site, based on Section A3.4 of the AISI S100-2012

ASTM & Code Standards

- ASTM A653/653M, A924/924M, A1003/1003M
- ASTM A1003, A653, A924, C624, C754
- AISI S240, 2012
- U.S. Patent #8,640,415 Bs
- ASTM E 1966: Standard Test Methods of Fire Tests of Firestop Systems
- UL 2079 Tests For Fire Resistance of Building Joints, 5th Edition.
- ASTM E-119 Standard Test Methods for Fire Tests of Building Construction and Material
- Air leakage tests conducted for compliance with Section 713.6 of IBC and CBC

LEED v4 for Building and Design Construction

- MR Prerequisite: Construction and Demolition Waste Management Planning
- MR: Credit: Construction and Demolition Waste Management
- MR Credit: Building Product Disclosure and Optimization - Sourcing of Raw Materials, Option 2
- MR Credit_ Building Product Disclosure and Optimization - Environmental Product Declarations, Options 1 & 2
- MR Credit: Building Product Disclosure and Optimization - Material Ingredients, Option 1
- MR Credit: Building Life-Cycle Impact Reduction, Option 4

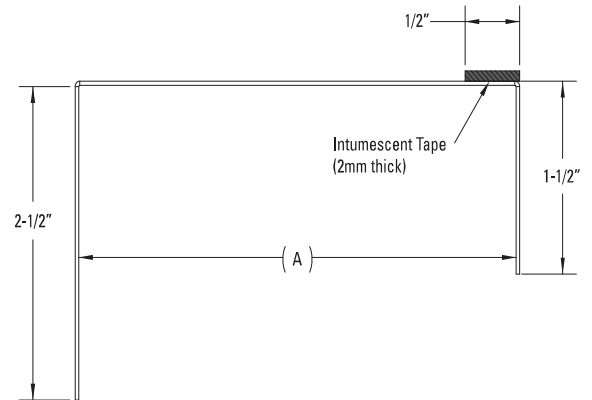
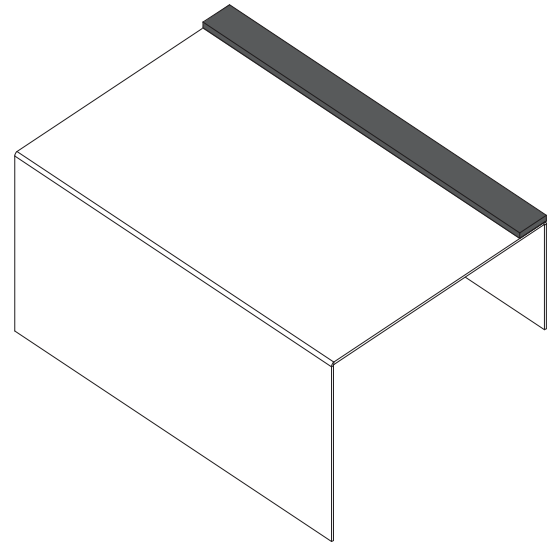

← Scan or click the code to view the installation video!



Always check UL Fire resistance directory for complete design requirements.

For more information, please contact MarinoWARE® Technical Services at 866.545.1545

This technical information reflects the most current information available and supersedes any and all previous publications effective

July 18, 2025 I MW_Firestop_Catalog I ©WARE Industries, Inc. 2025

HW-D-0625 1 HR. SHAFT WALL, CONCRETE SLAB

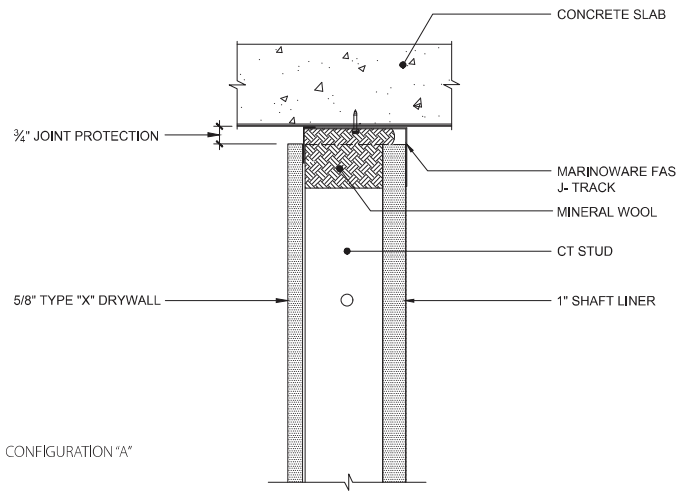

*NOTE: SINGLE LAYER OF 5/8" TYPE "X" DRYWALL FOR 1 HOUR FIRE RATING, 2 LAYERS FOR 2 HOUR

HW-D-0525 SHAFT WALL, PERPENDICULAR TO FLUTED DECK

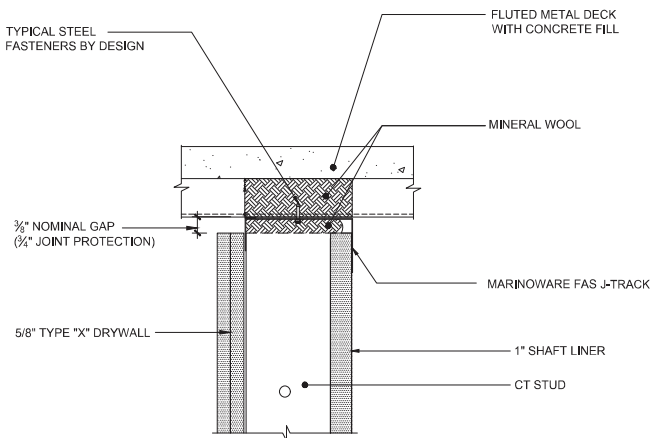

*NOTE: SINGLE LAYER OF 5/8" TYPE "X" DRYWALL FOR 1 HOUR FIRE RATING, 2 LAYERS FOR 2 HOUR

HW-D-0653 SHAFT WALL, PARALLEL & CANTILEVER UNDER BEAM

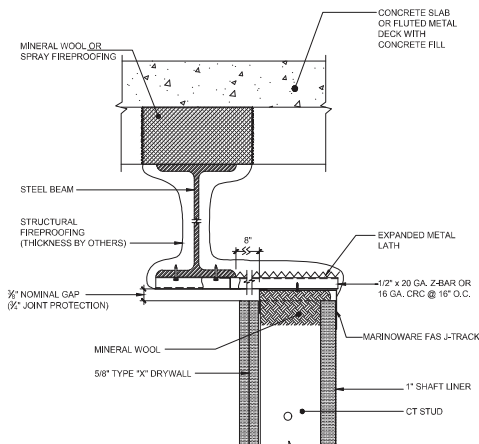

*NOTE: SINGLE LAYER OF 5/8" TYPE "X" DRYWALL FOR 1 HOUR FIRE RATING, 2 LAYERS FOR 2 HOUR

BW-S-0053 SHAFT WALL BOTTOM OF WALL

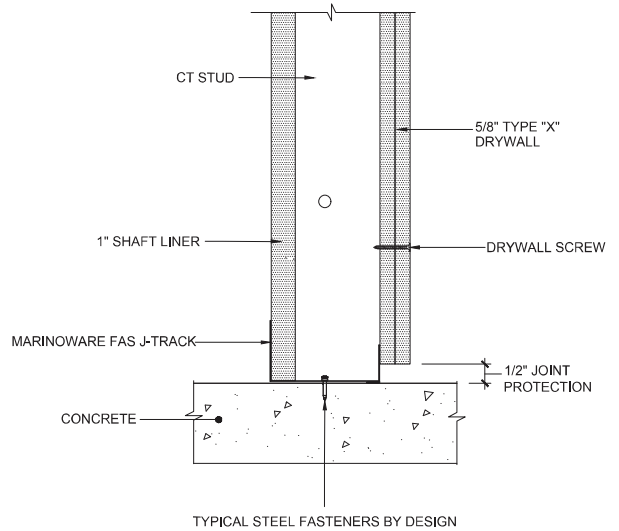

*NOTE: SINGLE LAYER OF 5/8" TYPE "X" DRYWALL FOR 1 HOUR FIRE RATING, 2 LAYERS FOR 2 HOUR

HW-D-0622 SHAFT WALL, DIRECTLY UNDER BEAM

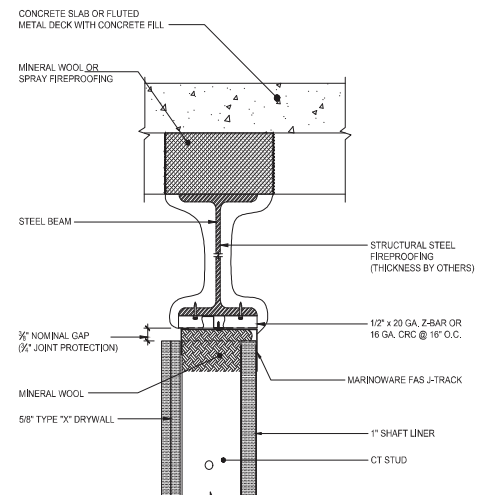

*NOTE: SINGLE LAYER OF 5/8" TYPE "X" DRYWALL FOR 1 HOUR FIRE RATING, 2 LAYERS FOR 2 HOUR

HW-D-0623 SHAFT WALL, @ FLUTED DECK BEAM PENETRATION

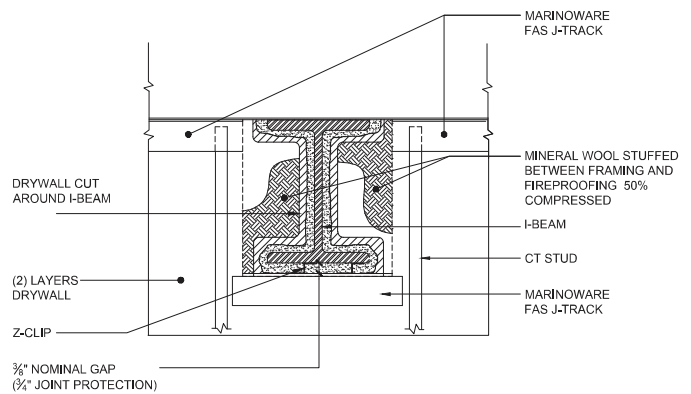

*NOTE: SINGLE LAYER OF 5/8" TYPE "X" DRYWALL FOR 1 HOUR FIRE RATING, 2 LAYERS FOR 2 HOUR

Always check UL Fire resistance directory for complete design requirements.

For more information, please contact MarinoWARE® Technical Services at 866.545.1545

This technical information reflects the most current information available and supersedes any and all previous publications effective July 18, 2025 | MW_Firestop_Catalog I ©WARE Industries, Inc. 2025