

## DEFLECTION CONNECTORS

### WSC 950 & WSC 1500

WSC 950 and 1500 Slide Clips provide lateral support for steel studs and allow for vertical movement of the building structure. They allow for 1-3/4" edge of slab tolerance from the existing supporting structure. The WSC Clips accommodate up to 3/4" vertical movement at intermediate floors and 1-1/2" vertical movement at roof levels. They are used in a vertical surface application. Simple and fast to install which saves time and money. One clip fits all stud sizes, no right or left hand clips. Screws must be backed out 1/4 turn once installed.

**MATERIAL:** See Table

**FINISH:** Galvanized – G90

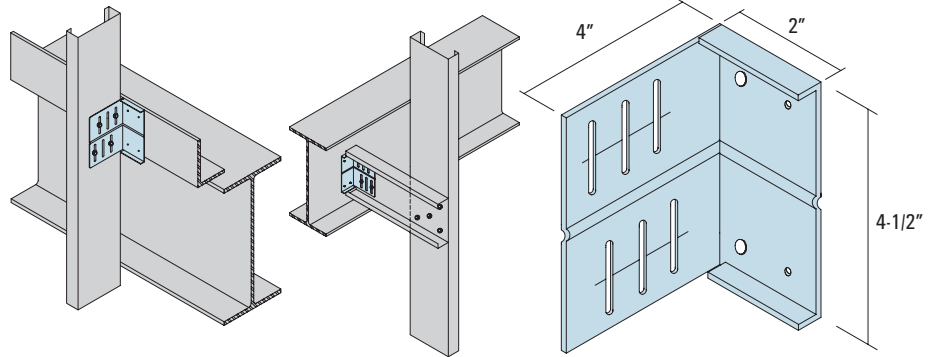

Model No.	Gauge (Mil) Yield	Box Quantity
WSC950	16 (54) 50ksi	25
WSC1500	12 (97) 40ksi	25

Screws not included for WSC1500 or WSC950

Connection to Structure Hilti X-U Powder Actuated Fastener in 3/16" Steel					Connection to Structure Hilti #12-14 Self Drilling Screws to 3/16" Steel				
Stud Thickness	# of Screws to Stud	# of Anchors to Structure	WSC 950	WSC 1500	Stud Thickness	Number of Screws	Number of Anchors	WSC 950	WSC 1500
			Allowable Load (lbs.)	Allowable Load (lbs.)				Allowable Load (lbs.)	Allowable Load (lbs.)
20ga. (33 mil) 33ksi	4	2	220	220	20ga. (33 mil) 33ksi	4	2	500	555
		3	335	335			3	557	555
		4	445	445			4	557	555
20ga. (33 mil) 33ksi	6	2	220	220	20ga. (33 mil) 33ksi	6	2	500	770
		3	335	335			3	750	835
		4	445	445			4	835	835
18ga. (43 mil) 33ksi	4	2	220	220	18ga. (43 mil) 33ksi	4	2	500	770
		3	335	335			3	750	824
		4	445	445			4	827	824
18ga. (43 mil) 33ksi	6	2	220	220	18ga. (43 mil) 33ksi	6	2	500	770
		3	335	335			3	750	1150
		4	445	445			4	945	1240
16ga. (54 mil) 33ksi	4	2	220	220	16ga. (54 mil) 33ksi	4	2	500	770
		3	335	335			3	750	1150
		4	445	445			4	945	1480
16ga. (54 mil) 33ksi	6	2	220	220	16ga. (54 mil) 33ksi	6	2	500	770
		3	335	335			3	750	1150
		4	445	445			4	945	1480
16ga. (54 mil) 50ksi	4	2	220	220	16ga. (54 mil) 50ksi	4	2	500	770
		3	335	335			3	750	1150
		4	445	445			4	945	1480
16ga. (54 mil) 50ksi	6	2	220	220	16ga. (54 mil) 50ksi	6	2	500	770
		3	335	335			3	750	1150
		4	445	445			4	945	1495
14ga. (68 mil) 50ksi	4	2	220	220	14ga. (68 mil) 50ksi	4	2	500	770
		3	335	335			3	750	1150
		4	445	445			4	945	1480
14ga. (68 mil) 50ksi	6	2	220	220	14ga. (68 mil) 50ksi	6	2	500	770
		3	335	335			3	750	1150
		4	445	445			4	945	1495

**Notes:**

1. All anchors must be attached in a single file line down the center of the clip, do not use predrilled holes if attaching with PAF.
2. All anchor data is from the Hilti 2009 Product Technical Guide.
3. All anchors must be attached to structure per manufacturer's instructions.
4. All manufacturer's guidelines must be followed for anchor spacing and edge distance.