

# BXUV.U375 - FIRE-RESISTANCE RATINGS - ANSI/UL 263

## Design/System/Construction/Assembly Usage Disclaimer

- Authorities Having Jurisdiction should be consulted in all cases as to the particular requirements covering the installation and use of UL Certified products, equipment, system, devices, and materials.
- Authorities Having Jurisdiction should be consulted before construction.
- Fire resistance assemblies and products are developed by the design submitter and have been investigated by UL for compliance with applicable requirements. The published information cannot always address every construction nuance encountered in the field.
- When field issues arise, it is recommended the first contact for assistance be the technical service staff provided by the product manufacturer noted for the design. Users of fire resistance assemblies are advised to consult the general Guide Information for each product category and each group of assemblies. The Guide Information includes specifics concerning alternate materials and alternate methods of construction.
- Only products which bear UL's Mark are considered Certified.

---

## BXUV - Fire Resistance Ratings - ANSI/UL 263 Certified for United States

## BXUV7 - Fire Resistance Ratings - CAN/ULC-S101 Certified for Canada

See General Information for Fire-resistance Ratings - ANSI/UL 263 Certified for United States  
Design Criteria and Allowable Variances

See General Information for Fire Resistance Ratings - CAN/ULC-S101 Certified for Canada  
Design Criteria and Allowable Variances

### **Design No. U375**

March 05, 2018

**Nonbearing Wall Rating - 2 HR (Area Separation Wall, See Items 1, 2 and 3)**

**Bearing Wall Rating 2 Hr (Protected Wall, See Items 4 and 4A)**

**Nonbearing Wall Rating 2 Hr (Protected Wall, See Item 4B and 4C)**

**Finish Rating - (See Item 6)**

**\* Indicates such products shall bear the UL or cUL Certification Mark for jurisdictions employing the UL or cUL Certification (such as Canada), respectively.**

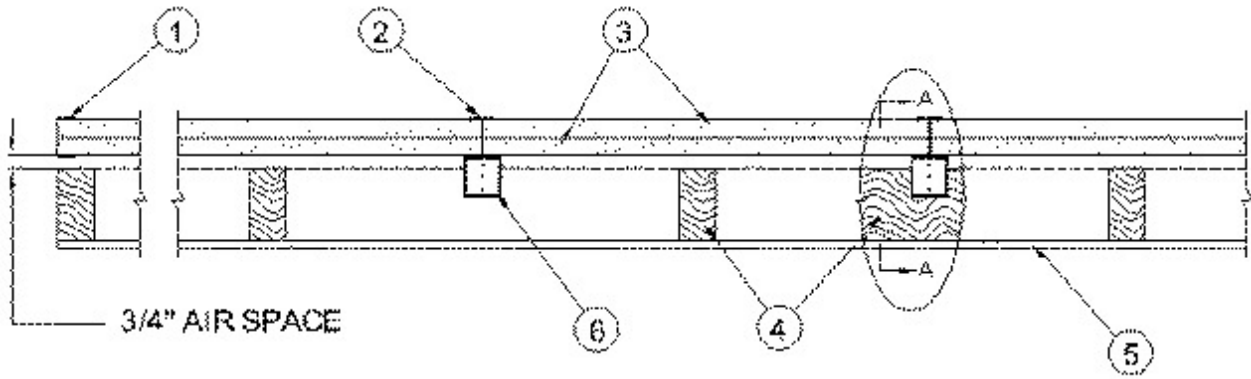

### CONFIGURATION A

EXPOSED TO FIRE FROM AREA SEPARATION WALL SIDE ONLY

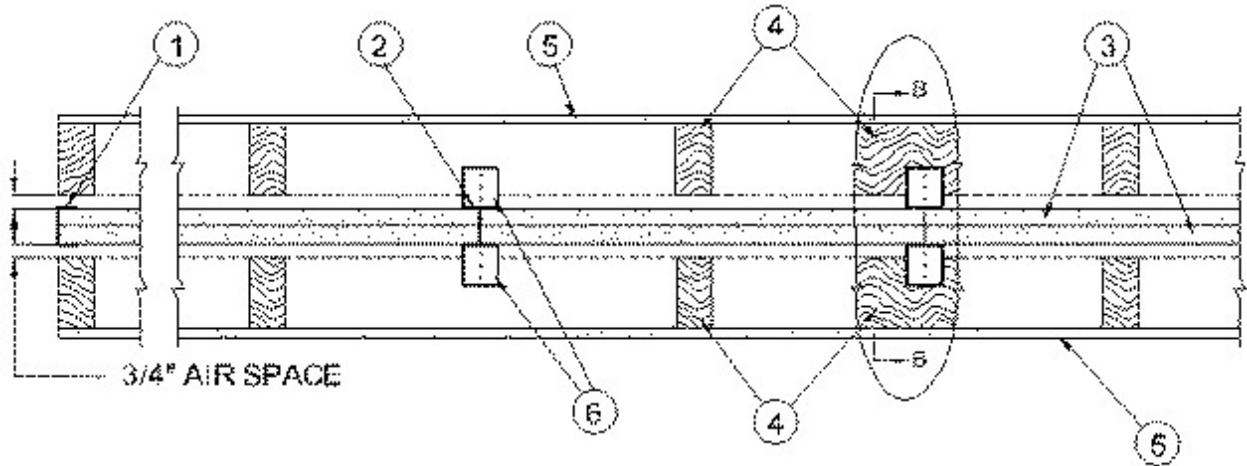

### CONFIGURATION B

EXPOSED TO FIRE FROM EITHER SIDE

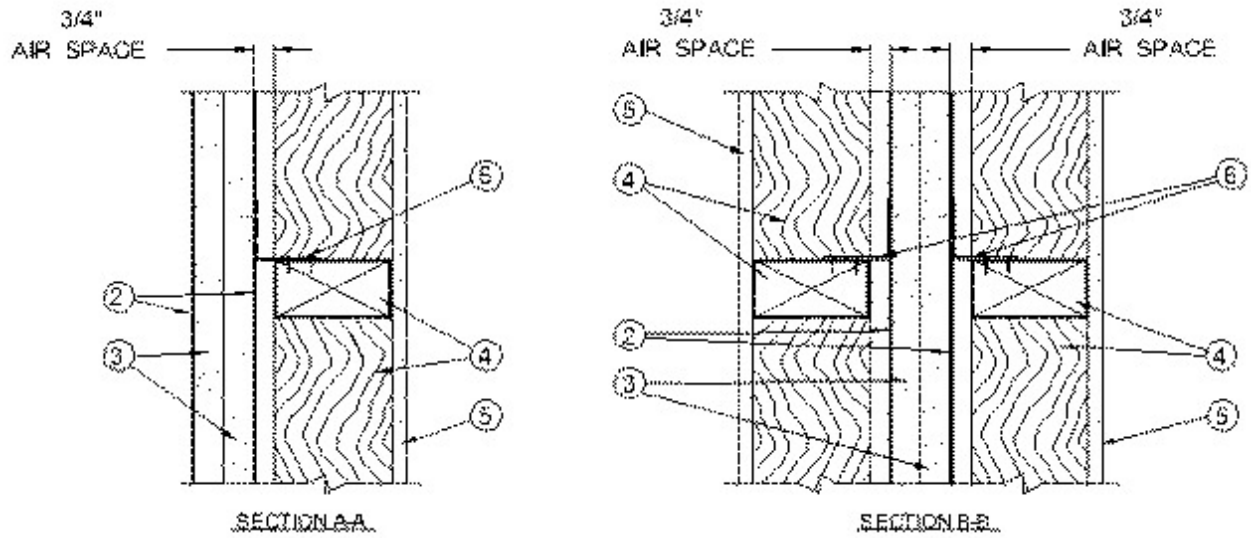

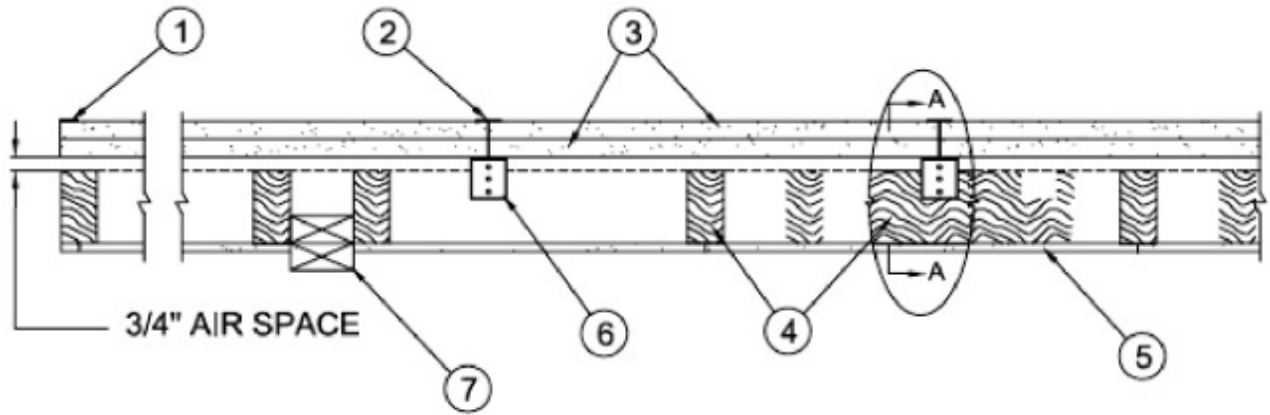

Configuration C

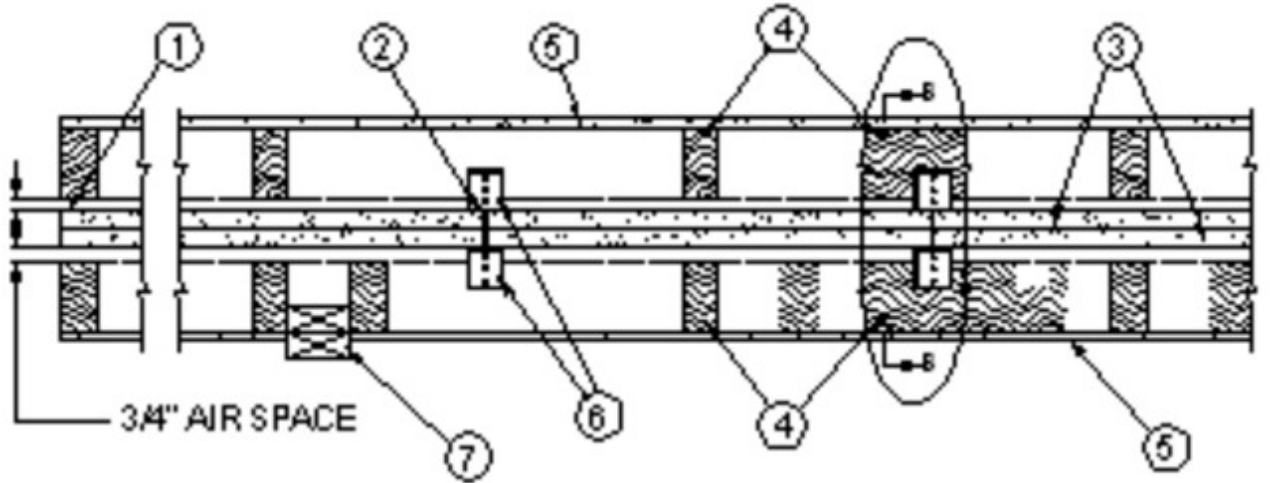

CONFIGURATION D

EXPOSED TO FIRE FROM EITHER SIDE

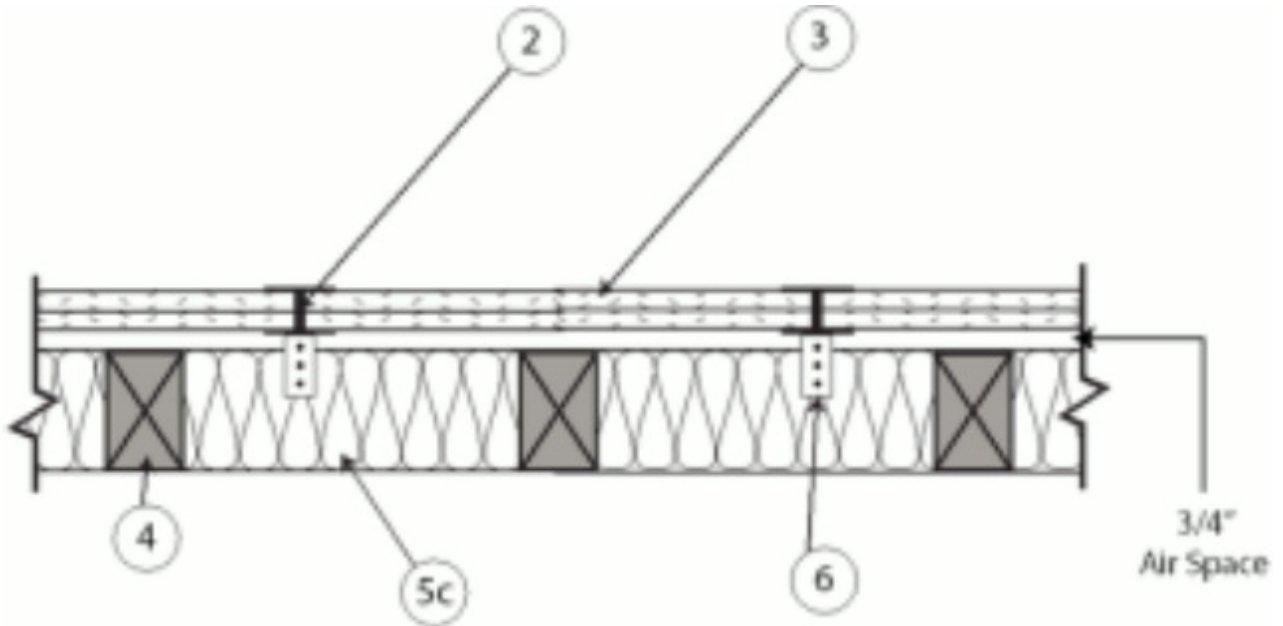

Configuration E

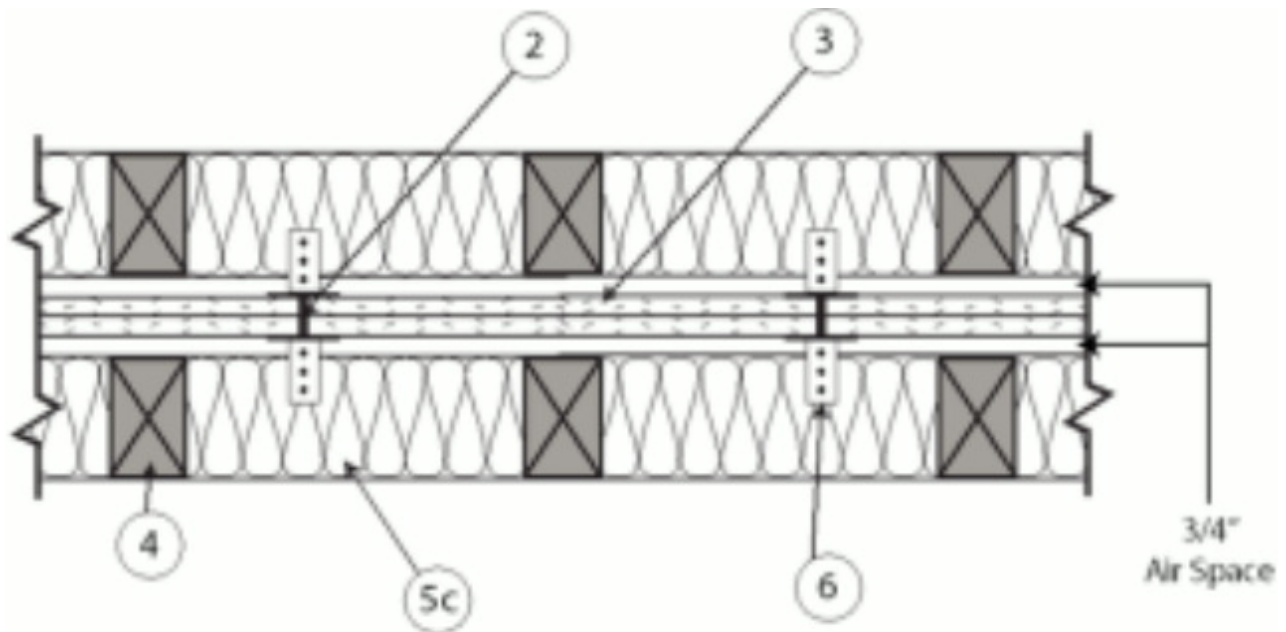

### Configuration F

#### **AREA SEPARATION WALL (Nonbearing Wall) — (Max Height - See Item 3)**

**1. Floor, Intermediate or Top Wall Track** — 2 in. wide channel shaped with 1 in. long legs formed from No. 25 MSG galv steel, secured with suitable fasteners spaced 24 in. OC.

**2. Steel Studs** — Steel members formed from No. 25 MSG galv steel having "H" - shaped flanged spaced 24 in. OC; overall depth 2 in. and flange width 1-3/8 in.

**3. Gypsum Board\*** — Two layers of 1 in. thick gypsum board liner panels, supplied in nom 24 in. widths. Vertical edges of panels friction fitted into "H" - shaped studs.

**AMERICAN GYPSUM CO** — Types AG-S (Max Height - 66 ft), M-Glass (Max Height - 66 ft)

**GEORGIA-PACIFIC GYPSUM L L C** — Type TP-6 (Max Height - 66 ft), Type DGUSL (Max Height - 44 ft), Type TRSL (Max. Height - 44 ft)

**PROTECTED WALL:** (Bearing or Nonbearing Wall as indicated under Items 4, through 4G. When Bearing, Load Restricted for Canadian Applications — See Guide BXUV7.)

**4. Wood Studs** — Bearing or Nonbearing Wall. Nom 2 by 4 in. max spacing 24 in. OC. Studs oriented with 2 in. face parallel to liner panels (Item No. 3). Studs cross-braced where necessary for clip attachment. Min 3/4 in. separation between wood framing and area separation wall. Studs may be also be orientated with 2 in. face perpendicular to liner panels if Type AG-S or M-Glass panels are used.

**4A. Steel Studs** — (As an alternate to Item 4, not shown) — For Bearing Wall - Corrosion protected steel studs, min No. 20 MSG (0.0329 in., min bare metal thickness) steel or min 3- 1/2 in. wide, min No. 20 GSG (0.036 in. thick) galv steel or No. 20 MSG (0.033 in. thick) primed steel, cold formed, shall be designed in accordance with the current edition of the Specification for the Design of Cold-Formed Steel Structural Members by the American Iron and Steel Institute. All design details enhancing the structural integrity of the wall assembly, including the axial design load of the studs, shall be as specified by the steel stud designer and/or producer, and shall meet the requirements of all applicable local code agencies. The max stud spacing of wall assemblies shall not exceed 24 in. OC. Studs attached to floor and ceiling tracks with 1/2 in. long Type S-12 steel screws on both sides of studs or by welded or bolted connections designed in accordance with the AISI specifications. Top and bottom tracks shall consist of steel members, min No. 20 MSG (0.0329 in., min bare metal thickness) steel or min No. 20 GSG (0.036 in. thick) galv steel or No. 20 MSG (0.033 in. thick) primed steel, that provide a sound structural connection between steel studs, and to adjacent assemblies such as a floor, ceiling, and/or other walls. Attached to floor and ceiling assemblies with steel fasteners spaced not greater than 24 in. O.C. Studs cross-braced with stud

**4B. Steel Studs** — (As an alternate to Items 4 and 4A) - For Nonbearing Wall - Channel shaped, fabricated from min 25 MSG corrosion-protected steel, min 3-1/2 in. wide, min 1-1/4 in. flanges and 1/4 in. return, spaced a max of 24 in. OC. Studs to be cut 3/8 to 3/4 in. less than assembly height. Top and bottom tracks shall be channel shaped, fabricated from min 25 MSG corrosion-protected steel, min width to accommodate stud size, with min 1 in. long legs, attached to floor and ceiling with fasteners 24 in. OC max. Studs cross-braced with stud framing at midheight where necessary for clip attachment. Min 3/4 in. separation between steel framing and area separation wall.

**4C. Framing Members\* — Steel Studs** — (As an alternate to Item 4, 4A, and 4B) - For Nonbearing Wall. Proprietary channel shaped studs, 3-5/8 in. wide spaced a max of 24 in. OC. Studs to be cut 3/4 in less than the assembly height and installed with a 1/2 in. gap between the end of the stud and track at the bottom of the wall. Studs cross-braced with stud framing at midheight where necessary for clip attachment. Min 3/4 in. separation between steel framing and area separation wall.

**CALIFORNIA EXPANDED METAL PRODUCTS CO** — Viper25™

**CRACO MFG INC** — SmartStud25™

**MARINO/WARE, DIV OF WARE INDUSTRIES INC** — Viper25™

**FUSION BUILDING PRODUCTS** — Viper25™

**IMPERIAL MANUFACTURING GROUP INC** — Viper25™

**TELLING INDUSTRIES L L C** — Viper25™

**4E. Framing Members\* — Floor and Ceiling Runner** — For use with Item 4C, proprietary channel shaped runners, 3-5/8 in. wide attached to floor and ceiling with fasteners 24 in. OC max.

**CALIFORNIA EXPANDED METAL PRODUCTS CO** — Viper25™ Track

**CRACO MFG INC** — SmartTrack25™

**MARINO/WARE, DIV OF WARE INDUSTRIES INC** — Viper25™ Track

**FUSION BUILDING PRODUCTS** — Viper25™ Track

**IMPERIAL MANUFACTURING GROUP INC** — Viper25™ Track

**TELLING INDUSTRIES L L C** — Viper25™ Track

**4F. Framing Members\* — Steel Studs** — (As an alternate to Item 4, 4A, 4B, and 4CD) - For Nonbearing Wall. Proprietary channel shaped studs, 3-5/8 in. wide spaced a max of 24 in. OC. Studs to be cut 3/4 in less than the assembly height and installed with a 1/2 in. gap between the end of the stud and track at the bottom of the wall. Studs cross-braced with stud framing at midheight where necessary for clip attachment. Min 3/4 in. separation between steel framing and area separation wall.

**STUDCO BUILDING SYSTEMS** — CROCSTUD

**4G. Framing Members\* — Floor and Ceiling Runner** — For use with Item 4F, proprietary channel shaped runners, 3-5/8 in. wide attached to floor and ceiling with fasteners 24 in. OC max.

**STUDCO BUILDING SYSTEMS** — CROCSTUD Track

**5. Gypsum Board** — Classified or Unclassified — Min 1/2 in thick, 4 ft wide, applied either horizontally or vertically. Gypsum board attached to wood studs with 1-1/4 in. long steel drywall nails spaced 8 in. OC or 1 in. long Type W coarse thread steel screws spaced 12 in. OC. Gypsum board attached to steel studs with 1 in. long Type S or S-12 steel screws spaced 12 in. OC. Vertical joints located over studs. Joints may or may not be covered with paper tape and joint compound. Nail or screw heads may or may not be covered with joint compound.

**5A. Gypsum Board** — (As an alternate to Item 5) Nom 5/8 in thick, 4 ft wide, applied either horizontally or vertically. Gypsum board attached to wood studs with 1-1/4 in. long steel drywall nails space 8 in. OC or 1 in. long Type W coarse thread steel screws spaced 12 in. OC. Gypsum board attached to steel studs with 1 in. long Type S or S-12 steel screws spaced 12 in. OC. Vertical joints located over studs. Joints may or may not be covered with paper tape and joint compound. Nail or screw heads may or may not be covered with joint compound.

**GEORGIA-PACIFIC GYPSUM L L C** — Type X ComfortGuard Sound Deadening Gypsum Board

**5B. Plywood Sheathing or OSB** — (Not Shown) — As an alternate to Item 5 or 5A, Min 1/2 in. thick plywood or OSB applied horizontally or vertically to wood or steel studs. Vertical joints located over studs. Horizontal joints shall be butted tight to form a closed joint. Fastened to studs with nails or screws of sufficient length, spaced 12 in. OC. Joints and fastener heads are not required to be treated.

5C. **Batts and Blankets\*** — (Not Shown) — As an alternate to Items 5, 5A and 5B when Types AG-S, M-Glass or TP-6 are used. Glass fiber or mineral wool insulation, min. 3-1/2 in. thick, placed to completely fill the wood or steel stud cavities. See Batts and Blankets (BKNV) category in the Building Materials Directory and Batts and Blankets (BZJZ) category in the Fire Resistance Directory for name of Classified Companies.

6. **Attachment Clips** — Aluminum angle, min. 0.063 in. thick, min 2 in. wide with min 2 in. and 2-1/4 in. legs or min. 0.050 in. thick, min. 2 in. wide with min 2 in. and 2-1/2 in. legs. Clips secured with Type S screws min. 3/8 in. long to "H" studs or steel studs and with Type W screws min. 1-1/4 in. long to wood framing through holes provided in clip.

<b>System No.</b>	<b>Height Limitation</b>
<b>1</b>	<b>23 ft</b>
<b>2</b>	<b>44 ft</b>
<b>3</b>	<b>66 ft</b>

For wood studs, the Finish Rating of the various Configurations is 120 minutes, unless Configuration A, C or E are used at a height exceeding 44 ft., in which case the Finish Rating is 115 min. Finish rating has not been evaluated for steel studs.

### **System 1**

6A. Clip placement (Item 6) for separation walls up to 23 ft high: Space clips a max of 10 ft OC vertically between wood or steel framing and "H" studs.

### **System 2**

6B. Clip placement (Item 6) for separation walls up to 44 ft high. Space clips as described in Item 6A for upper 24 ft. Remaining wall area below requires clips spaced a max 5 ft OC vertically between wood or steel framing and "H" studs.

### **System 3**

6C. Clip placement (Item 6) for separation walls up to 66 ft high: Space clips as described in Item 6A for upper 24 ft. Space clips as described in item 6B for next 20 ft. below the upper 24 ft. Remaining wall area below requires clips spaced a max of 40 in. OC vertically between wood or steel framing and "H" studs.



**7. Non-Bearing Wall Partition Intersection** — (Optional) — For wood framing — Two nominal 2 by 4 in. stud or nominal 2 by 6 in. stud nailed together with two 3in. long 10d nails spaced a max. 16 in. OC. vertically and fastened to one side of the minimum 2 by 4 in. stud with 3 in. long 10d nails spaced a max 16 in. OC. vertically. Intersection between partition wood studs to be flush with the 2 by 4 in. studs. The wall partition wood studs are to be framed with a second 2 by 4 in. wood stud fastened with 3 in. long 10d nails spaced a max. 16 in. OC. vertically. Maximum one non-bearing wall partition intersection per stud cavity. Non-bearing wall partition stud depth shall be at a minimum equal to the depth of the wall.

**\* Indicates such products shall bear the UL or cUL Certification Mark for jurisdictions employing the UL or cUL Certification (such as Canada), respectively.**

Last Updated on 2018-03-05

---

The appearance of a company's name or product in this database does not in itself assure that products so identified have been manufactured under UL's Follow-Up Service. Only those products bearing the UL Mark should be considered to be Certified and covered under UL's Follow-Up Service. Always look for the Mark on the product.

UL permits the reproduction of the material contained in the Online Certification Directory subject to the following conditions: 1. The Guide Information, Assemblies, Constructions, Designs, Systems, and/or Certifications (files) must be presented in their entirety and in a non-misleading manner, without any manipulation of the data (or drawings). 2. The statement "Reprinted from the Online Certifications Directory with permission from UL" must appear adjacent to the extracted material. In addition, the reprinted material must include a copyright notice in the following format: "© 2019 UL LLC"