

# BXUV.U388 - FIRE-RESISTANCE RATINGS - ANSI/UL 263

## Design/System/Construction/Assembly Usage Disclaimer

- Authorities Having Jurisdiction should be consulted in all cases as to the particular requirements covering the installation and use of UL Certified products, equipment, system, devices, and materials.
- Authorities Having Jurisdiction should be consulted before construction.
- Fire resistance assemblies and products are developed by the design submitter and have been investigated by UL for compliance with applicable requirements. The published information cannot always address every construction nuance encountered in the field.
- When field issues arise, it is recommended the first contact for assistance be the technical service staff provided by the product manufacturer noted for the design. Users of fire resistance assemblies are advised to consult the general Guide Information for each product category and each group of assemblies. The Guide Information includes specifics concerning alternate materials and alternate methods of construction.
- Only products which bear UL's Mark are considered Certified.

---

## BXUV - Fire Resistance Ratings - ANSI/UL 263 Certified for United States

## BXUV7 - Fire Resistance Ratings - CAN/ULC-S101 Certified for Canada

See General Information for Fire-resistance Ratings - ANSI/UL 263 Certified for United States  
Design Criteria and Allowable Variances

See General Information for Fire Resistance Ratings - CAN/ULC-S101 Certified for Canada  
Design Criteria and Allowable Variances

### **Design No. U388**

March 05, 2018

**Nonbearing Wall Rating — 2 Hr (Area Separation Wall, See Items 1,2 and 3)**

**Bearing or Non Bearing Wall Rating 2 Hr (Protected Wall, See Item 4)**

**Finish Rating — 120 Min**

**\* Indicates such products shall bear the UL or cUL Certification Mark for jurisdictions employing the UL or cUL Certification (such as Canada), respectively.**

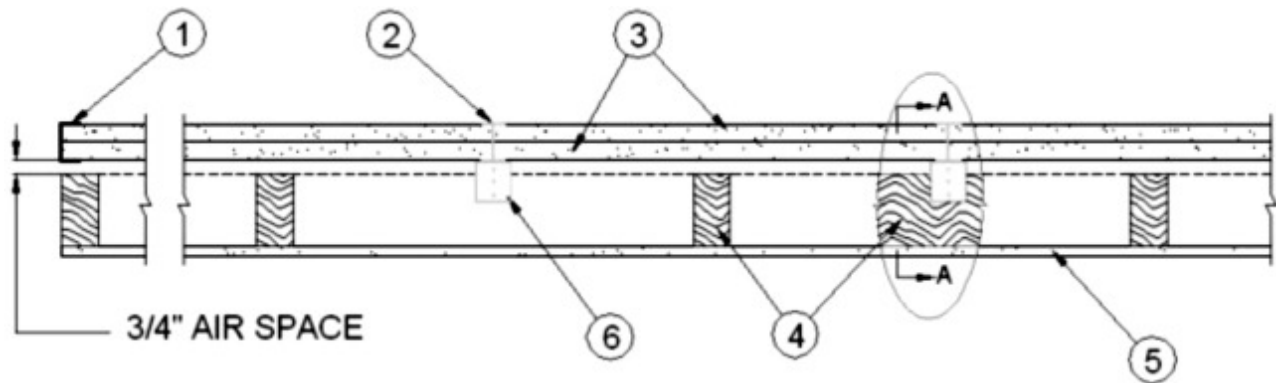

### CONFIGURATION A

**EXPOSED TO FIRE FROM AREA SEPARATION WALL SIDE ONLY**

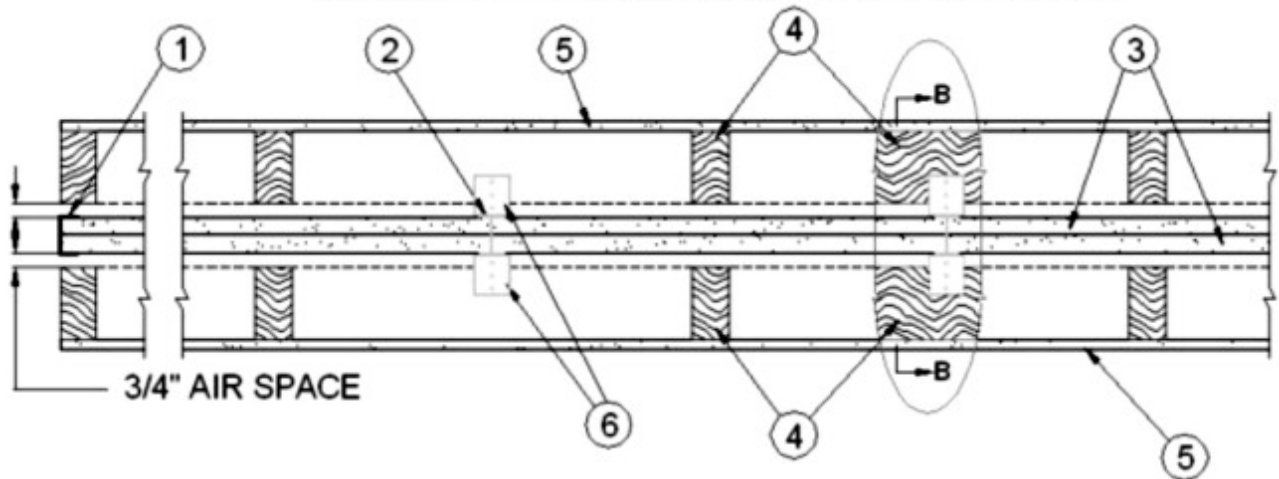

### CONFIGURATION B

**EXPOSED TO FIRE FROM EITHER SIDE**

**AREA SEPARATION WALL:** (Max Height - 66 ft)

1. **Floor, Intermediate, or Top Wall** — 2 in. wide channel shaped with 1 in. long legs formed from No. 25 MSG galv steel, secured with suitable fasteners spaced 24 in. OC.
2. **Steel Studs** — H-shaped steel studs fabricated from 25 MSG galv. steel, 2 in. deep with 1-3/8 in. wide flanges, spaced a maximum of 24 in. OC.
3. **Gypsum Board\*** — Two layers of 1 in. thick gypsum wallboard liner panels, supplied in nom 24 in. widths. Vertical edges of panels friction fitted into "H" -shaped studs.  
**CONTINENTAL BUILDING PRODUCTS OPERATING CO, L L C** — 1 in. thick Type LGFCSL

**PROTECTED WALL:** (Bearing or Nonbearing Wall. When Bearing, Load Restricted for Canadian Applications — See Guide BXUV7.)

4. **Wood Studs** — Nom 2 by 4 in. max spacing 24 in. OC. Studs cross braced at mid-height where necessary for clip attachment. Min 3/4 in. separation between wood framing and fire separation wall.

**5. Gypsum Board** — Classified or Unclassified — Min 1/2 in. thick, 4 ft wide, applied either horizontally or vertically. Wallboard attached to studs with 1-1/4 in. long steel drywall nails spaced 8 in. OC. Vertical joints located over studs. (Optional) Joints covered with paper tape and joint compound. Nail heads covered with joint compound.

**5A. Wood Structural Panels** — As an alternate to Item 5, Min 7/16 in. thick, 4 ft wide wood structural panels, compliant with DOC PS-1 (plywood) or PS-2 (OSB). Installed with long dimension of sheet parallel with or perpendicular to studs. Vertical joints centered on studs. Attached to studs with min. 6d cement coated nails or 1-1/4 in. ring shank nails spaced 8 in. OC.

**6. Attachment Clips** — Aluminum angle, 0.063 in. thick, 2 in. wide with 2 in. and 2-1/4 in. legs. Clips secured with 3/8 in. long Type S drywall screws to "H" studs and with Type W screws 1-1/4 in. long to wood framing through holes provided in clip. Clips are spaced a maximum of 10 ft. OC. vertically between wood framing and "H" studs for separation walls up to 23 ft. high. For separation walls up to 44 ft. high, clips spaced as described above for the upper 24 ft. and the remaining wall areas below requires clips spaced a maximum of 5 ft. OC. vertically between wood framing and "H" studs.

**6A. Attachment Clips** — Clip placement (Item 6) for separation walls up to 66 ft high: Space clips as described in Item 6 for upper 24 ft. Space clips as described in item 6 for next 20 ft. below the upper 24 ft. Remaining wall area below requires clips spaced a max of 40 in. OC vertically between wood framing and "H" studs.

**\* Indicates such products shall bear the UL or cUL Certification Mark for jurisdictions employing the UL or cUL Certification (such as Canada), respectively.**

Last Updated on 2018-03-05

---

The appearance of a company's name or product in this database does not in itself assure that products so identified have been manufactured under UL's Follow-Up Service. Only those products bearing the UL Mark should be considered to be Certified and covered under UL's Follow-Up Service. Always look for the Mark on the product.

UL permits the reproduction of the material contained in the Online Certification Directory subject to the following conditions: 1. The Guide Information, Assemblies, Constructions, Designs, Systems, and/or Certifications (files) must be presented in their entirety and in a non-misleading manner, without any manipulation of the data (or drawings). 2. The statement "Reprinted from the Online Certifications Directory with permission from UL" must appear adjacent to the extracted material. In addition, the reprinted material must include a copyright notice in the following format: "© 2019 UL LLC"