

Marino\WARE® Product Submittal Data

MARINO\WARE PART # HDW358

(used with RCC358 clip only)

MATERIAL: 1/4" Structural Steel, 36 ksi

FINISH: Gray Paint

Model No.	Stud Size	Dimensions (in.)	Box Qty.
HDW358	3-5/8"	1/4 x 1-5/16 x 3-1/4	50
HDW600	6"	1/4 x 1-5/16 x 5-1/4	50
HDW800	8"	1/4 x 1-5/16 x 7-3/4	25

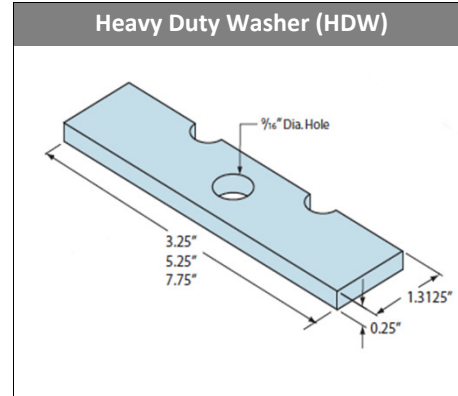

Allowable Strength of RCC with HDW (Washer) in Moment (M1)

CFS Member		Allowable Strength (in-kips)						Flexibility (Rad/in-lb x106)	
		RCC358		RCC600		RCC800			
Thickness (mils/ga.)	Fy (ksi)	No. of Screws		No. of Screws		No. of Screws			
		3	6	3	6	5	10		
33 (20)	33	0.99	1.94	2.15	2.35	3.37	3.82		
		28.4	8.07	4.06	4.06	6.39	1.70		
43 (18)	33	0.99	1.94	2.15	2.35	3.37	3.82		
		28.4	8.07	4.06	4.06	6.39	1.70		
54 (16)	50	2.10	3.99	4.38	4.69	8.06	8.03		
		28.4	8.07	4.06	4.06	6.39	1.70		
68 (14)	50	2.10	3.99	4.38	4.69	8.06	8.03		
		28.4	8.07	4.06	4.06	6.39	1.70		
97 (12)	50	2.10	3.99	4.38	4.69	8.06	8.03		
		28.4	8.07	4.06	4.06	6.39	1.70		

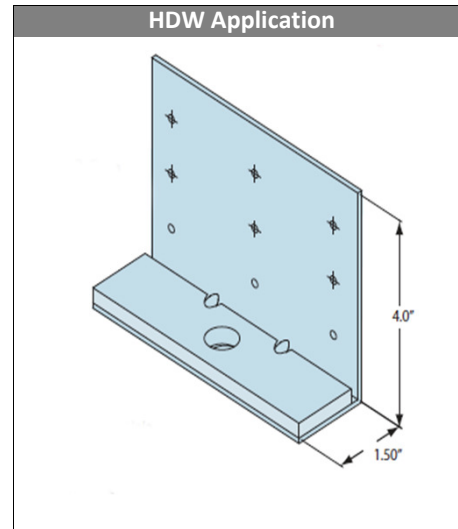

GREEN INFO LEED® v3

Available LEED® points in the following categories:

- MR Credit 2 - Construction Waste Management (1-2 points)
- MR Credit 4 - Recycled Content (1-2 points)
- MR Credit 5 - Regional Materials (1-2 points)

- Total Recycled Content: 34.9%
- Post Consumer Content: 24.3%
- Pre Consumer (Post Industrial) Content: 9.4%



www.marinoware.com

For more information, please contact Marino\WARE Technical Services at 866-545-1545.

This technical information reflects the most current information available and supersedes any and all publications, effective 12/1/2013

© Copyright 2013 by Ware Industries, Inc. All rights reserved

Allowable Strength of RCC with HDW (Washer) in Shear (F1)

CFS Member		Allowable Strength (lbs.)					
Thickness (mils/ga.)	Fy (ksi)	RCC358		RCC600		RCC800	
		No. of Screws		No. of Screws		No. of Screws	
		3	6	3	6	5	10
33 (20)	33	480	480	660	760	980	980
43 (18)	33	480	480	660	760	980	980
54 (16)	50	1,070	1,100	1,450	1,670	2,160	2,160
68 (14)	50	1,070	1,100	1,450	1,670	2,160	2,160
97 (12)	50	1,070	1,100	1,450	1,670	2,160	2,160

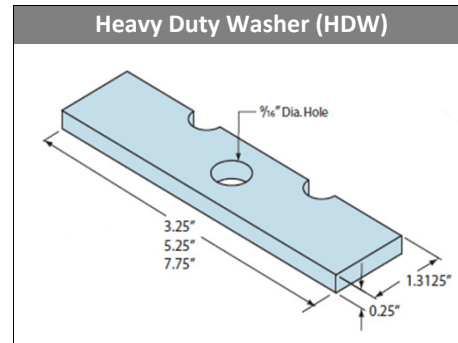

Allowable Strength of RCC with HDW (Washer) in Tension/Compression (F2)

CFS Member		Allowable Strength (lbs.)					
Thickness (mils/ga.)	Fy (ksi)	RCC358		RCC600		RCC800	
		No. of Screws		No. of Screws		No. of Screws	
		3	6	3	6	5	10
33 (20)	33	530	1,060	530	1,060	884	1,767
43 (18)	33	789	1,578	789	1,578	1,315	2,630
54 (16)	50	1,602	3,205	1,602	2,219	2,671	3,244
68 (14)	50	1,640	3,244	1,640	3,205	2,733	3,244
97 (12)	50	1,640	3,244	1,640	3,244	2,733	3,244

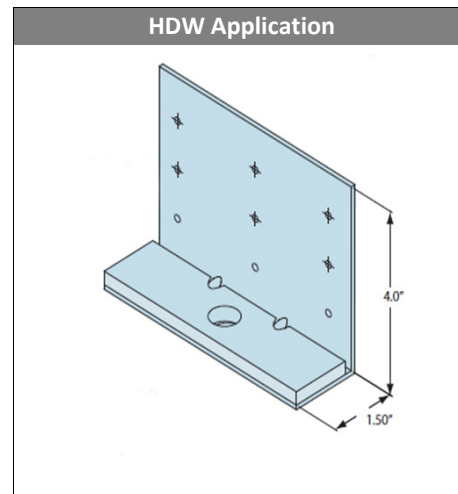

Notes:

1. Tabulated values are based on #10-16 screws with ultimate shear capacity of 1,600 lbs per screw.
2. Allowable loads have not been increased for wind or seismic.
3. It is the responsibility of the design professional to design the connection of the RCC to the supporting structure.
4. Use linear interaction for combination of F1, F2, and M1.
5. The 1/4" thick Heavy Duty Washer (HDW) meets ASTM A36 Standard Specification for Carbon Structural Steel.
6. Tabulated loads are based on a 1/2" diameter bolt, with 1/2" Type A plain washer, a nominal outside diameter of 1.062 and nominal thickness of 0.095".

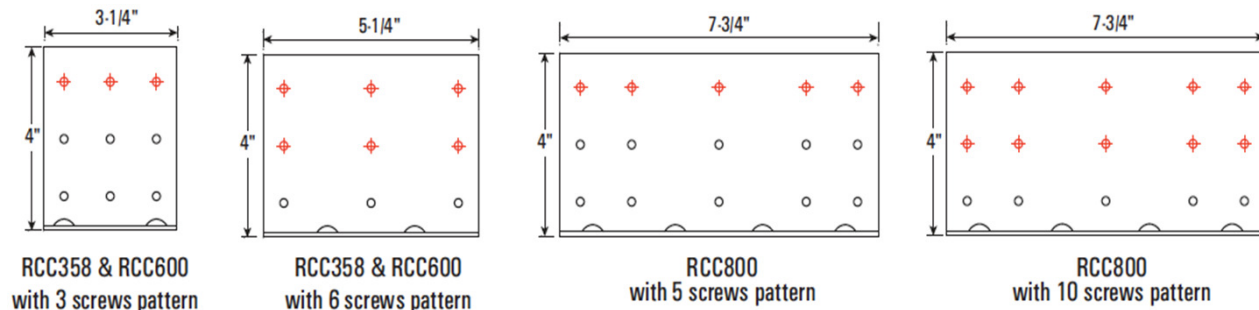

www.marinoware.com

For more information, please contact Marino\WARE Technical Services at 866-545-1545.

This technical information reflects the most current information available and supersedes any and all publications, effective 12/1/2013
© Copyright 2013 by Ware Industries, Inc. All rights reserved