

SLOTTED TRACK



PRODUCT CATALOG



100% American-Owned and Operated | marinoware.com

Slotted Track

MARINO\WARE®

SLOTTED TRACK

Cold formed steel slotted track is designed for use at the head of wall to protect the integrity of walls during building movement by absorbing vertical movement caused by expansion and contraction, wind forces and seismic events. Slotted track walls are positively secured to both flanges of the stud, for greater load resistance and protection from lateral movement while allowing vertical deflection of a structure. Slotted track is formed from steel conforming to ASTM requirements for cold formed steel and is code compliant for dynamic head of wall joints.

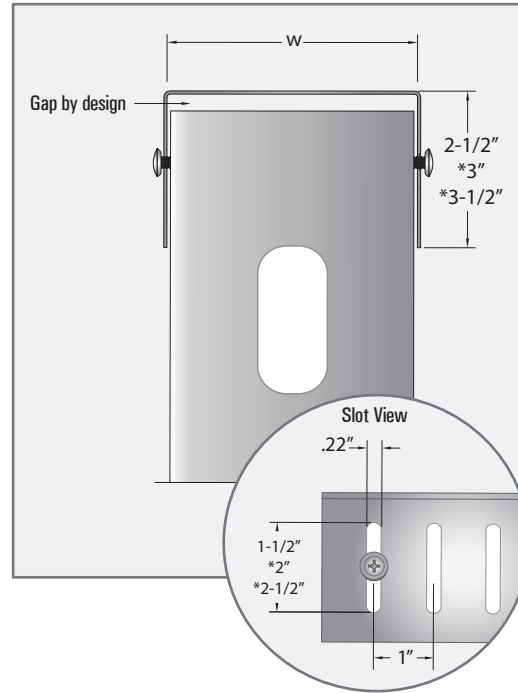

LEG SIZE	SLOT SIZE	WEB DEPTH	GAUGE (mil)	DESIGN THICKNESS	MINIMUM THICKNESS	YIELD (ksi)	COATING
2-1/2"	1-1/2"	2-1/2" to 6"	25 GA (18)	0.0188	0.0179	40	G40
		2-1/2" to 6"	20 GA (30)	0.0312	0.0296	40	G40
		2-1/2" to 8"	20 GA (33)	0.0346	0.0329	40	G60
		2-12" to 10"	18 GA (43)	0.0451	0.0428	33	G60
		2-1/2" to 10"	16 GA (54)	0.0566	0.0538	50	G60
		3-5/8" to 10"	14 GA (68)	0.0713	0.0677	50	G60
3"	2"	2-1/2" to 6"	20 GA (30)	0.0312	0.0296	40	G40
		2-1/2" to 8"	20 GA (33)	0.0346	0.0329	40	G60
3-1/2"	2-1/2"	2-1/2" to 6"	20 GA (30)	0.0312	0.0296	40	G40
		2-1/2" to 8"	20 GA (33)	0.0346	0.0329	40	G60

CODE COMPLIANCE

MarinoWARE Slotted Track meets all standard building codes and Underwriter's Laboratory (UL 2079). Slotted Track meets or exceeds the following: ASTM A1003, C645, C955, C1007, E119, AISI S100.



3M

HW-D-0020	HW-D-0101	HW-D-0173
HW-D-0021	HW-D-0111	HW-D-0205
HW-D-0029	HW-D-0134	HW-D-0265
HW-D-0031	HW-D-0170	

A/D SYSTEMS

HW-D-0247	HW-D-0315	HW-D-0320
HW-D-0249	HW-D-0316	
HW-D-0314	HW-D-0317	

EGS-NELSON

HW-D-0223	HW-D-0239	HW-D-0309
HW-D-0224	HW-D-0283	HW-D-0310
HW-D-0227	HW-D-0288	HW-D-0393
HW-D-0228	HW-D-0304	
HW-D-0238	HW-D-0305	

FLAME-TECH

HW-D-0523

GRABBER

HW-D-0547

HILTI

HW-D-0042	HW-D-0154	HW-D-0342
HW-D-0045	HW-D-0184	HW-D-0388
HW-D-0046	HW-D-0190	HW-D-0396
HW-D-0049	HW-D-0209	HW-D-0541
HW-D-0076	HW-D-0218	HW-D-0542
HW-D-0077	HW-D-0259	HW-D-0545
HW-D-0082	HW-D-0264	HW-D-0564
HW-D-0083	HW-D-0292	HW-D-0569
HW-D-0084	HW-D-0295	HW-D-0570
HW-D-0085	HW-D-0313	HW-D-0571
HW-D-0087	HW-D-0321	HW-D-0572
HW-D-0089	HW-D-0322	
HW-D-0106	HW-D-0324	

PFPP

HW-D-0024	HW-D-0072	HW-D-0271
HW-D-0025	HW-D-0073	HW-D-0272
HW-D-0036	HW-D-0162	HW-D-0278
HW-D-0062	HW-D-0185	HW-D-0546
HW-D-0063	HW-D-0191	
HW-D-0071	HW-D-0263	

RECTORSEAL

HW-D-0032	HW-D-0129	HW-D-0297
HW-D-0033	HW-D-0130	HW-D-0298
HW-D-0058	HW-D-0144	HW-D-0299
HW-D-0059	HW-D-0146	HW-D-0380
HW-D-0104	HW-D-0179	HW-D-0381
HW-D-0105	HW-D-0180	
HW-D-0107	HW-D-0217	
HW-D-0108	HW-D-0221	
HW-D-0127	HW-D-0222	
HW-D-0128	HW-D-0257	

STI

HW-D-0003	HW-D-0137	HW-D-0371
HW-D-0034	HW-D-0152	HW-D-0377
HW-D-0043	HW-D-0194	HW-D-0456
HW-D-0044	HW-D-0210	HW-D-0457
HW-D-0054	HW-D-0241	HW-D-0483
HW-D-0079	HW-D-0242	HW-D-0484
HW-D-0088	HW-D-0243	HW-D-0485
HW-D-0099	HW-D-0252	HW-D-0486
HW-D-0102	HW-D-0260	HW-D-0548
HW-D-0103	HW-D-0363	HW-D-0549
HW-D-0136	HW-D-0365	

*Note: Check UL Directory for latest information.

Warranty & Limitations

All products presented herein are warranted to the buyer to be free from defects in material and workmanship. The foregoing warranty is non-assignable and in lieu of and excludes all other warranties not expressly set forth herein, whether express or implied by operation of law or otherwise, including but not limited to any implied warranties of merchantability or fitness for a particular purpose. All details and specifications presented herein are intended as a general guide for the use of MarinoWARE® framing systems. These products should not be used without evaluation by a qualified engineer or architect to determine their suitability for a specific use.

MarinoWARE® assumes no responsibility for failure resulting from use of its details or specifications, or for failure resulting from improper application or installation of these products.

Governing Law

All issues arising in connection with your order and all transactions associated with it shall be interpreted according to the laws of the State of New Jersey, and all actions or other proceedings arising out of such issues shall be brought only in Superior Court, State of New Jersey, County of Essex, or United States District Court for the District of New Jersey. No action may be brought more than one year after accrual of the cause of action therefore.



www.MarinoWARE.com

For more information, please contact MarinoWARE® Technical Services at 866-545-1545.

This technical information reflects the most current information available and supersedes any and all previous publications effective April 20, 2022 | MW-Slotted Track Catalog | © WARE Industries, Inc. 2022



100% American-Owned and Operated | marinoware.com

New Jersey Facility
400 Metuchen Road
South Plainfield, NJ 07080
800.627.4661
908.757.9000
Fax: 908.412.1442

Georgia Facility
777 Greenbelt Parkway
Griffin, GA 30223
800.504.8199
678.688.1312
Fax: 678.688.1379

Indiana Facility
4245 Railroad Avenue
East Chicago, IN 46312
866.636.6002
219.378.7100
Fax: 219.378.7106

New York Sales Office
51 John St., B1
Babylon, NY 11702
800.627.4667
631.691.2200
Fax: 631.691.1492

Engineering Office
100 Hendrick Drive, Suite 200
McDonough, GA 30253
866.545.1545
678.688.7780
Fax: 770.507.2605

www.MarinoWARE.com

For more information, please contact Marino|WARE® Technical Services at 866.545.1545

This technical information reflects the most current information available and supersedes any and all previous publications effective April 20, 2022 | MW-SlottedTrack Catalog | © WARE Industries, Inc. 2022