



DEPARTMENT OF REGULATORY AND ECONOMIC RESOURCES
BOARD AND CODE ADMINISTRATION DIVISION

MIAMI-DADE COUNTY
PRODUCT CONTROL SECTION
11805 SW 26 Street, Room 208
Miami, Florida 33175-2474
T (786) 315-2590 F (786) 315-2599

www.miamidade.gov/economy

NOTICE OF ACCEPTANCE (NOA)

Wellbilt International Corporation
14030 N.W. 82nd Avenue
Miami Lakes, Florida 33016

SCOPE:

This NOA is being issued under the applicable rules and regulations governing the use of construction materials. The documentation submitted has been reviewed and accepted by Miami-Dade County RER-Product Control Section to be used in Miami Dade County and other areas where allowed by the Authority Having Jurisdiction (AHJ).

This NOA shall not be valid after the expiration date stated below. The Miami-Dade County Product Control Section (In Miami Dade County) and/or the AHJ (in areas other than Miami Dade County) reserve the right to have this product or material tested for quality assurance purposes. If this product or material fails to perform in the accepted manner, the manufacturer will incur the expense of such testing and the AHJ may immediately revoke, modify, or suspend the use of such product or material within their jurisdiction. RER reserves the right to revoke this acceptance, if it is determined by Miami-Dade County Product Control Section that this product or material fails to meet the requirements of the applicable building code.

This product is approved as described herein, and has been designed to comply with the High Velocity Hurricane Zone of the Florida Building Code.

DESCRIPTION: Sure-Board Wall Panel System

APPROVAL DOCUMENT: Drawing No. 15-149, titled " Sure-Board Wall Panel ", sheets 1 through 10 of 10, prepared by Tilteco, Inc., dated May 22, 2015 with revision #1 dated May 22, 2015, signed and sealed by Walter A. Tillit Jr., P.E., on May 26, 2015 bearing the Miami-Dade County Product Control Revision stamp with the Notice of Acceptance number and the expiration date by the Miami-Dade County Product Control Section.

MISSILE IMPACT RATING: Large and Small Missile Impact Resistant

LABELING: Each panel shall bear a permanent label with the manufacturer's name or logo, city, state and the following statement: "Miami-Dade County Product Control Approved", unless otherwise noted herein.

RENEWAL of this NOA shall be considered after a renewal application has been filed and there has been no change in the applicable building code negatively affecting the performance of this product.

TERMINATION of this NOA will occur after the expiration date or if there has been a revision or change in the materials, use, and/or manufacture of the product or process. Misuse of this NOA as an endorsement of any product, for sales, advertising or any other purposes shall automatically terminate this NOA. Failure to comply with any section of this NOA shall be cause for termination and removal of NOA.

ADVERTISEMENT: The NOA number preceded by the words Miami-Dade County, Florida, and followed by the expiration date may be displayed in advertising literature. If any portion of the NOA is displayed, then it shall be done in its entirety.

INSPECTION: A copy of this entire NOA shall be provided to the user by the manufacturer or its distributors and shall be available for inspection at the job site at the request of the Building Official. An original signed and sealed company letter from Wellbilt Industries, LLC is required, providing that the Sure-Board Wall Panel System was purchased from them in order for this NOA to be valid on any job.

This NOA revises NOA #14-1030.12 and consists of this page 1, evidence submitted pages E-1, E-2, E-3 & E-4 as well as approval document mentioned above.

The submitted documentation was reviewed by Helmy A. Makar, P.E., M.S.



Helmy A. Makar
02/11/2016

NOA No. 15-0601.10
Expiration Date: 11/27/2019
Approval Date: 02/11/2016

Wellbilt International Corporation

NOTICE OF ACCEPTANCE: EVIDENCE SUBMITTED

- 1. EVIDENCE SUBMITTED UNDER PREVIOUS APPROVAL #03-1015.08**
 - A. DRAWINGS**
 1. *Drawing No. 02-385, titled " Wall Panel System ", sheets 1 through 10 of 10, prepared by Tilteco, Inc., dated July 11, 2002 with last revision #1 dated January 7, 2004, signed and sealed by Walter A. Tillit Jr., P.E.*
 - B. TEST**
 1. *Test report on Large Missile Impact test, Cyclic Wind Pressure test and Uniform Static Air Pressure test and Air & Water Infiltration tests and ASTM E 72-98 on Composite Wall Panels over Galvanized Steel Studs, prepared by American Test Lab of South Florida, report No. 0506.01-03, dated September 5, 2003, signed and sealed by William R. Mehner, P.E. and Henry Hattem, PE.*
 2. *Addendum to report No. 0506.01-03, dated December 15, 2003, signed and sealed by William R. Mehner, P.E. and Henry Hattem, PE.*
 - C. CALCULATIONS**
 1. *Panel allowable calculation and Anchors' verification prepared by Walter A. Tillit Jr., P.E. dated august 27, 2003 signed and sealed by Walter A Tillit Jr., PE.*
 - D. QUALITY ASSURANCE**
 1. *By Miami-Dade County Building Code Compliance Office.*
 - E. MATERIAL CERTIFICATION**
 1. *Tensile test report of metal panel, prepared by Q. C. Metallurgical, Inc., dated August 4, 2003, signed and sealed by Frank E. Grate, Jr., P E.*
 2. *Copy of N.O.A. # 00-1114.05.*
- 2. EVIDENCE SUBMITTED UNDER PREVIOUS APPROVAL # 05-0929.09**
 - A. DRAWINGS**
 1. *Drawing No. 05-291, titled " Wall Panel System ", sheets 1 through 10 of 10, prepared by Tilteco, Inc., dated September 16, 2005 with last revision #1 dated September 16, 2005, signed and sealed by Walter A. Tillit Jr., P.E.*
 - B. TEST**
 1. *None.*
 - C. CALCULATIONS**
 1. *Panel Anchors' verification per FBC 2004 edition prepared by Walter A. Tillit Jr., P.E. dated September 21, 2005 signed and sealed by Walter A Tillit Jr., PE.*
 - D. QUALITY ASSURANCE**
 1. *By Miami-Dade County Building Code Compliance Office.*
 - E. MATERIAL CERTIFICATION**
 1. *None.*

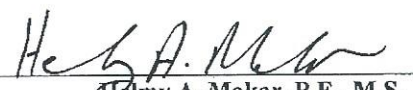
Helmy A. Makar, P.E., M.S.
Product Control Section Supervisor
NOA No. 15-0601.10
Expiration Date: 11/27/2019
Approval Date: 02/11/2016

Wellbilt International Corporation

NOTICE OF ACCEPTANCE: EVIDENCE SUBMITTED

3. EVIDENCE SUBMITTED UNDER PREVIOUS APPROVAL # 08-1126.08

A. DRAWINGS

1. *Drawing No. 08-219, titled " Sure-Board Wall Panel ", sheets 1 through 10 of 10, prepared by Tilteco, Inc., dated October 01, 2008 with last revision #1 dated October 01, 2008, signed and sealed by Walter A. Tillit Jr., P.E., on December 15, 2008.*

B. TEST

1. *None.*

C. CALCULATIONS

1. *Calculation titled "Revision of Miami-Dade County Product Approval Anchor Calculations " by Walter A. Tillit Jr., P.E. dated November 24, 2008 signed and sealed by Walter A Tilit Jr., PE.*

D. QUALITY ASSURANCE

1. *By Miami-Dade County Building Code Compliance Office.*

E. MATERIAL CERTIFICATION

1. *Copy of N.O.A. # 05-0929.09*

4. EVIDENCE SUBMITTED UNDER PREVIOUS APPROVAL # 10-0519.09

A. DRAWINGS

1. *Drawing No. 08-219, titled " Sure-Board Wall Panel ", sheets 1 through 10 of 10, prepared by Tilteco, Inc., dated October 01, 2008 with last revision #2 dated June 28, 2010, signed and sealed by Walter A. Tillit Jr., P.E., on July 01, 2010.*

B. TEST

1. *None.*

C. CALCULATIONS

1. *None.*

D. QUALITY ASSURANCE

1. *By Miami-Dade County Building Code Compliance Office.*

E. MATERIAL CERTIFICATION

1. *Copy of N.O.A. # 08-1126.08*

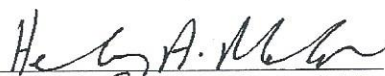
Henry A. Makar, P.E., M.S.

Product Control Section Supervisor

NOA No. 15-0601.10

Expiration Date: 11/27/2019

Approval Date: 02/11/2016

Wellbilt International Corporation

NOTICE OF ACCEPTANCE: EVIDENCE SUBMITTED

5. EVIDENCE SUBMITTED UNDER PREVIOUS APPROVAL # 12-0229.07

A. DRAWINGS

1. *Drawing No. 12-009, titled " Sure-Board Wall Panel ", sheets 1 through 10 of 10, prepared by Tilteco, Inc., dated January 17, 2012 with last revision #1 dated January 17, 2012, signed and sealed by Walter A. Tillit Jr., P.E., on January 25, 2012.*

B. TEST

1. *None.*

C. CALCULATIONS

1. *None.*

D. QUALITY ASSURANCE

1. *By Miami-Dade County Department of Regulatory and Economic Resources (RER).*

E. MATERIAL CERTIFICATION

1. *None.*

F. OTHERS

1. *Florida Building Code, 2010 Edition Compliance letter, issued by Tilteco, Inc., dated February 01, 2012, signed and sealed by Walter A. Tillit Jr., P.E.*

6. EVIDENCE SUBMITTED UNDER PREVIOUS APPROVAL # 14-1030.12

A. DRAWINGS

1. *Drawing No. 13-089, titled " Sure-Board Wall Panel ", sheets 1 through 10 of 10, prepared by Tilteco, Inc., dated December 09, 2013 with revision #1 dated December 09, 2013, signed and sealed by Walter A. Tillit Jr., P.E., on October 20, 2014.*

B. TEST

1. *None.*

C. CALCULATIONS

1. *None.*

D. QUALITY ASSURANCE

1. *By Miami-Dade County Department of Regulatory and Economic Resources.*

E. MATERIAL CERTIFICATION

1. *None.*

F. OTHERS

1. *Florida Building Code, 2010 Edition Compliance letter, issued by Tilteco, Inc., dated October 17, 2014, signed and sealed by Walter A. Tillit Jr., P.E.*

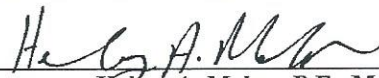

Melmy A. Makar, P.E., M.S.
Product Control Section Supervisor
NOA No. 15-0601.10
Expiration Date: 11/27/2019
Approval Date: 02/11/2016

Wellbilt International Corporation

NOTICE OF ACCEPTANCE: EVIDENCE SUBMITTED

7. NEW EVIDENCE SUBMITTED

A. DRAWINGS

1. *Drawing No. 15-149, titled " Sure-Board Wall Panel ", sheets 1 through 10 of 10, prepared by Tilteco, Inc., dated May 22, 2015 with revision #1 dated May 22, 2015, signed and sealed by Walter A. Tillit Jr., P.E., on May 26, 2015.*

B. TEST

1. *None.*

C. CALCULATIONS

1. *None.*

D. QUALITY ASSURANCE

1. *By Miami-Dade County Department of Regulatory and Economic Resources.*

E. MATERIAL CERTIFICATION

1. *None.*

F. OTHERS

1. *Florida Building Code, 2014 Edition Compliance letter, issued by Tilteco, Inc., dated May 21, 2015, signed and sealed by Walter A. Tillit Jr., P.E.*

Henry A. Makar, P.E., M.S.

Product Control Section Supervisor

NOA No. 15-0601.10

Expiration Date: 11/27/2019

Approval Date: 02/11/2016

GENERAL NOTES:

- THIS PRODUCT APPROVAL DOCUMENT (P.A.D.) APPLIES ONLY TO THE STRUCTURAL WALL PANELS INDICATED AND SPECIFIED ON THIS DRAWING. HAS BEEN VERIFIED FOR COMPLIANCE IN ACCORDANCE WITH THE 2014 (5th EDITION) OF THE FLORIDA BUILDING CODE.
DESIGN WIND LOADS SHALL BE DETERMINED AS PER SECTIONS 1620 OF THE ABOVE MENTIONED CODE, USING ASCE 7-10 AND SHALL NOT EXCEED THE MAXIMUM (A.S.D.) DESIGN PRESSURE RATINGS INDICATED ON THIS SHEET.
IN ORDER TO VERIFY THE ABOVE CONDITION, ULTIMATE DESIGN WIND LOADS DETERMINED PER ASCE 7-10 SHALL BE FIRST REDUCED TO A.S.D. DESIGN WIND LOADS BY MULTIPLYING THEM BY 0.6 IN ORDER TO COMPARE THESE W/ MAX. (A.S.D.) DESIGN PRESSURE RATINGS INDICATED ON THIS SHEET.

DESIGN DEAD AND LIVE LOADS SHALL BE DETERMINED IN ACCORDANCE WITH SECTION 1616 OF THE FLORIDA BUILDING CODE.

- BUILDING DIMENSIONS, DETAILS, UPLIFT, OVERTURNING, FOUNDATION, ROOF AND OTHER ELEMENTS WHERE WALL PANELS WILL BE INSTALLED SHALL BE DESIGNED BY A FLORIDA REGISTERED PROFESSIONAL ENGINEER OR ARCHITECT AND REVIEWED BY THE STRUCTURAL PLANS EXAMINER OF THE CORRESPONDING BUILDING DEPARTMENT IN ORDER TO ISSUE A PERMIT FOR CONSTRUCTION.

- ALL ELECTRICAL, MECHANICAL DETAILS AND PARTS AND FIRE RATING PROVISIONS ARE NOT PART OF THIS APPROVAL AND SHALL BE PREPARED BY A FLORIDA REGISTERED PROFESSIONAL ENGINEER AND REVIEWED BY THE CORRESPONDING BUILDING DEPARTMENT IN ORDER TO ISSUE A PERMIT FOR CONSTRUCTION.

- ALL STEEL STUDS AND SKIN SHALL HAVE STRUCTURAL QUALITY ASTM A-653, GRADE 40 Min. WITH 47.0 KSI Min. YIELD STRENGTH (AFTER ROLLED), G-60 GALVANIZED STEEL DESIGNATION FOR STUDS AND G-90 FOR SKIN.

- ALL SCREWS SHALL BE CORROSION RESISTANT AS PER DIN 50018 WITH FLAT HEAD AND RAISED SIDES TO PREVENT EXCESSIVE PENETRATION WITH MIN. $F_y = 80$ ksi & SHALL COMPLY W/ FLORIDA BUILDING CODE SECTION 2411.3.3.4.

- ANCHORS TO CONCRETE FLOOR, FOUNDATION, SHALL BE AS FOLLOWS:

- 1/4" Ø CRETE-FLEX ANCHORS AS MANUFACTURED BY ELCO CONSTRUCTION PRODUCTS WITH 1 3/4" MINIMUM EMBEDMENT INTO $f'_c=3350$ psi POURED CONCRETE.
- 1/2" Ø POWERS POWER-STUD + SD2 ANCHORS AS MANUFACTURED BY POWERS FASTENERS, INC. WITH 5" MINIMUM EMBEDMENT INTO $f'_c=3350$ psi POURED CONCRETE.
- 1/2" Ø KWIK BOLT EXPANSION ANCHORS AS MANUFACTURED BY HILTI, INC. WITH 5" MINIMUM EMBEDMENT INTO $f'_c=3350$ psi POURED CONCRETE.
- ANCHORS SHALL BE INSTALLED FOLLOWING ALL OF THE RECOMMENDATIONS AND SPECIFICATIONS OF THE ANCHOR'S MANUFACTURER.

NOTE: TO VERIFY THAT ANCHORS ARE NOT OVERSTRESSED IN THESE PRODUCT APPROVAL DOCUMENTS (P.A.D.), A 33% INCREASE IN ALLOWABLE LOADS WAS NOT USED IN THE ANCHORS ANALYSIS.

- WALL PANEL SYSTEM IS DESIGNED TO BE INSTALLED AS AN EXTERIOR BEARING WALL OR CURTAIN WALL:
- WHEN INSTALLED AS A BEARING WALL, PANEL SHALL BE LATERALLY SUPPORTED BY A CONCRETE SLAB AND FOUNDATION AT THE BOTTOM, AND ROOF TRUSSES OR RAFTERS WITH SHEATHING AT TOP. AT A SPACINGS NOT TO EXCEED 24" ON CENTERS. WALL CONNECTION TO ROOF SYSTEM SHALL BE PERFORMED BY A FLORIDA REGISTERED PROFESSIONAL ENGINEER OR ARCHITECT AND REVIEWED BY THE STRUCTURAL PLANS EXAMINER OF THE CORRESPONDING BUILDING DEPARTMENT IN ORDER TO ISSUE A PERMIT FOR CONSTRUCTION. STRUCTURAL DESIGN SHALL INCLUDE PROVISIONS FOR ALL LOADS DEVELOPED AT THE JOINT BETWEEN WALL PANELS AND ROOF SYSTEM.

Warning note:

Attention Building Official / Building Inspector.
An 'original signed and company sealed letter' from Wellbilt International is required proving that the panels were purchased from them in order for this NOA to be valid on any job.

FLORIDA BUILDING CODE (High Velocity Hurricane Zone)

SURE-BOARD® WALL PANEL

WELLBILT INTERNATIONAL CORP.
14030 N.W. 62 AVE
MIAMI LAKES, FL 33016
PHONE: (305) 884-8020 FAX: (305) 884-8029

REV. No	DESCRIPTION	DATE	REV. No	DESCRIPTION	DATE
1	OLD 13-089	05/22/15	3		
2			4		

© 2015 TILTECO INC.



TILTECO INC.
TILITE TESTING & ENGINEERING COMPANY
6355 N.W. 56th St., Suite 100
Phone: (305) 987-1530 Fax: (305) 987-1531
e-mail: tilteco@aol.com
EB-0006719
WALTER A. TILLIT JR., P.E.
FLORIDA Lic. # 44167

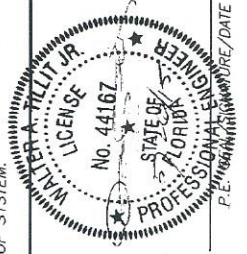

- WHEN INSTALLED AS A CURTAIN WALL, PANEL SHALL BE LATERALLY SUPPORTED BY CONCRETE SLABS/BEAMS, WOOD OR STEEL STRUCTURAL BEAMS. SPACING BETWEEN LATERAL SUPPORT SHALL NOT TO EXCEED 24" ON CENTERS ON BUILDINGS WITHOUT A CONCRETE SLAB. FOR BUILDINGS WITH CONCRETE SLABS OR CONTINUOUS CONCRETE BEAMS, INSTALLATION SHALL BE AS PER SECTION X-X, SHEET 4 OF 10, AND DETAIL 3 SHEET 10 OF 10.
STRUCTURAL ADEQUACY OF EXISTING BUILDING SHALL BE VERIFIED BY THE PERMIT HOLDER.
MAXIMUM A.S.D. ALLOWABLE: OBTAINED THRU TESTING PERFORMED AS PER TAS 201, 202, 203 AND ASTM E-72, AS PER AIL REPORT 0506.01-03 WITH ADDENDUM & REPORT #
LARGE MISSILE IMPACT RESISTANT: 80 FT/SEC. MISSILE SPEED.
MAXIMUM PANEL HEIGHT: 108"
MAXIMUM PANEL WIDTH: 48"
MAXIMUM A.S.D. COMPRESSION LOAD PER PANEL: 5200 Lb (1300 Lb/FT) *
MAXIMUM A.S.D. TENSION LOAD PER PANEL: 2600 Lb (650 Lb/FT) *
MAXIMUM A.S.D. RACKING LOAD PER PANEL: 2200 Lb (550 Lb/FT) *
MAXIMUM LATERAL A.S.D. DESIGN PRESSURE RATING FOR PANELS WITH STUDS @ 16" o.c.: ±64.3 psf

* ONLY SOLID PANELS (WITH NO OPENINGS) SHALL BE CONSIDERED TO RESIST THE RACKING FORCES, COMPRESSION AND TENSION LOADS.

- ELECTRIC SERVICE DROP CONDUCTORS OR ANY OVERHEAD WIRING SHALL NOT EXIST OR BE INSTALLED OVER ANY PART OF THIS STRUCTURE.
- (g) THIS P.A.D. PREPARED BY THIS ENGINEER IS GENERIC AND DOES NOT PROVIDE INFORMATION FOR A SITE SPECIFIC PROJECT; I.E. WHERE THE SITE CONDITIONS DEVIATE FROM THE P.A.D.

- CONTRACTOR TO BE RESPONSIBLE FOR THE SELECTION, PURCHASE AND INSTALLATION INCLUDING LIFE SAFETY OF THIS PRODUCT BASED ON THIS P.A.D. PROVIDED HE/SHE DOES NOT DEVIATE FROM THE CONDITIONS DETAILED ON THIS DOCUMENT. CONSTRUCTION SAFETY AT SITE IS THE CONTRACTOR'S RESPONSIBILITY.

(c) THIS P.A.D. WILL BE CONSIDERED INVALID IF MODIFIED.

- SITE SPECIFIC PROJECTS SHALL BE PREPARED BY A FLORIDA REGISTERED ENGINEER OR ARCHITECT WHICH WILL BECOME THE PROFESSIONAL OF RECORD (P.O.R.) FOR THE PROJECT AND WHO WILL BE RESPONSIBLE FOR THE PROPER USE OF THE P.A.D. PROFESSIONAL OF RECORD, ACTING AS A DELEGATED ENGINEER TO THE P.A.D. ENGINEER SHALL SUBMIT TO THIS LATTER THE SITE SPECIFIC DRAWINGS FOR REVIEW.

- ORIGINAL P.A.D. SHALL BEAR THE DATE AND ORIGINAL SEAL AND SIGNATURE OF THE PROFESSIONAL ENGINEER THAT PREPARED IT.

- A PERMANENT PANEL MANUFACTURER'S LABEL SHALL BE PLACED ON THE EXPOSED SURFACE OF THE PANEL. ONE LABEL SHALL BE PLACED FOR EVERY OPENING. LABEL SHALL READ AS FOLLOWS:
"SURE-BOARD® WALL PANEL"
WELLBILT INTERNATIONAL CORP.
MIAMI LAKES, FLORIDA
MIAMI-DADE COUNTY PRODUCT CONTROL APPROVED.

THIS DRAWING SHALL ONLY BE USED TO OBTAIN PERMITS IN THE STATE OF FLORIDA

PRODUCT REVISED as complying with the Florida Building Code
Acceptance No. **15-0601-10**
Expiration Date **11/27/2019**
By **Heather A. Tillit**
Miami-Dade Product Control
MIAMI DADE COUNTY

F.R.L. DRAWN BY	05/22/15
DATE	
DRAWING No	15-149
SHEET 1 OF 10	

SPECIFICATIONS FOR NON-METALLIC WALL COMPONENTS: (SEE SHEET 3 OF 10)

1. THE ACROCRETE ACROWALL DA SYSTEM PROVIDES WEATHER RESISTANT TO EXTERIOR WALL. THE UTILIZATION OF DURABLE CEMENTITIOUS BOARD SUBSTRATE (PERMABASE BOARD) TOUBROUGHT ACROCRETE ACROFINISH PROVIDES THE DESIRED ESTHETICS OF VARIOUS COLORS AND TEXTURES TO ACHIEVE AN ARCHITECTURALLY FINISHING WALL. THE ACROCRETE ACROWALL DA SYSTEM IS BACKED BY A 10 YEARS LIMITED MANUFACTURERS WARRANTY ON THE CEMENTITIOUS BOARD (PERMABASE BOARD) AND A 5 YEARS LIMITED MANUFACTURERS WARRANTY ON ALL COATINGS.

2. ACROCRETE EMULSION, MODEL 5-4253 BY SEACO SOUTHEASTERN ADHESIVE COMPANY, IS A READY TO USE ACRYLIC EMULSION THAT SHALL BE USED TO BOND THE PERMABASE BOARD TO THE GALVANIZED STEEL SKIN BEHIND IT CONSTITUTING THE SURE-BOARD® SYSTEM.

3. PERMABASE™ CEMENT BOARD BY NATIONAL GYPSUM COMPANY, IS A 1/2" THICK, CEMENTITIOUS TILE BACKER BOARD MADE OF PORTLAND CEMENT, AGGREGATE AND REINFORCED WITH FIBERGLASS MESH. THE BOTTOM (UNEXPOSED) SIDE FACING HAS A SMOOTH FINISH WITH A FIBERGLASS MESH EMBEDDED IN THE CEMENT SLURRY AND THE TOP (EXPOSED) SIDE FACING HAS A ROUGH FINISH WITH A FIBERGLASS MESH MECHANICALLY EMBEDDED INTO CORE WITH A WEIGHT OF 3.0 POUNDS PER SQUARE FOOT.

TEST METHOD	PERMABASE
FLEXURAL STRENGTH (psi)	750
ASTM C 947	3
ASTM C 473	5
FLAME SPREAD/SMOKE DEVELOPED	2250
ASTM D 2394	5/0
ASTM E 84	0.2/2.7
PROPERTY OF MATERIAL	
ANSI A118.1	204
ANSI A118.4	241
ANSI A136.1	159

4. ACROPROY BY ACROCRETE ARCHITECTURAL FINISHING SYSTEMS, INC., IS AN ACRYLIC ADHESIVE AND BASE COAT COMBINATION FOR THE ACROCRETE WALL SYSTEMS, USED TO EMBED REINFORCING MESH AND USED AS A LEVELING COAT. THE PROPER MIXING RATIO IS 12 Lb OF WATER TO 50 Lb/yr of ACROPROY, COVERING APPROXIMATELY 100 SQUARE FEET OF WALL.

5. ACROMESH BY ACROCRETE ARCHITECTURAL FINISHING SYSTEMS, INC., IS A SPECIALLY WOVEN AND TREATED FIBERGLASS REINFORCING HIGH IMPACT MESH, ALWAYS RESISTANT. THICKNESS: 0.045+108 oz./sq.yd., MINIMUM TENSILE WRAP: 800 Lb/yr AND MINIMUM TENSILE FILL: 550 Lb/yr.

6. ACROFINISH BY ACROCRETE ARCHITECTURAL FINISHING SYSTEMS, INC., IS A PREHINED DECORATIVE AND PROTECTIVE WALL COATING. IT IS FORMULATED WITH A 100% PURE ACRYLIC BASED COATINGS INCORPORATING FINE MARBLE AGGREGATES IN VARIETY OF COLOR AND TEXTURES. 70 Lb PAIL COVERS APPROXIMATELY 100-150 SQUARE FEET OF WALL DEPENDING ON TEXTURE.

7. ACROMESH AND ACROFINISH BY ACROCRETE ARCHITECTURAL FINISHING SYSTEMS, INC. BEAR ALSO A MIAMI-DADE COUNTY PRODUCT CONTROL ACCEPTANCE AS COMPONENTS OF A WALL SYSTEM.

8. ACROCRETE ACROWALL DA SYSTEM BEARS AN EVALUATION REPORT BASED ON THE FOLLOWING TESTING PERFORMED ON THIS PRODUCT:

- TEST REPORTS ON ACROCRETE, PREPARED BY APPLIED CONSUMER SERVICES INC.
- ACROCRETE ACROWALL DA SYSTEM, FIRE PROPAGATION UNDER MODIFIED ASTM E 108, PREPARED BY TESTING CONSULTANTS, INC. PROJECT NUMBER 002010.
- TEST REPORT ON SURFACE BURNING CHARACTERISTICS OF ACROBASE AND ACROCRETE FINISH APPLIED TO GRC BOARD, TESTED UNDER ASTM E-84, PREPARED BY COMMERCIAL TESTING COMPANY, REPORT NO. 75239.
- TEST REPORT ON HEATHERING EXPOSURE TESTS WITH XENON ARC AND RAIN CYCLES, UNDER ASTM G-26, PREPARED BY APPLIED CONSUMER SERVICES, INC. REPORT NUMBER 98-01.
- TEST REPORT ON IMPACT LOAD RESISTANCE OF ACROWALL DA FINISH SYSTEMS UNDER ENA TEST METHOD AND STANDARD 101.86, PREPARED BY ACROCRETE, INC.
- TEST REPORT ON PHYSICAL PROPERTIES, PREPARED BY JIM WALTER RESEARCH COMPANY. THE FOLLOWING TESTS WERE PERFORMED:
 - COMPRESSIVE STRENGTH UNDER ASTM C 203.
 - FLEXURAL STRENGTH UNDER ASTM C 272.
 - WATER VAPOR TRANSMISSION UNDER ASTM E 96.
 - DIMENSIONAL STABILITY UNDER ASTM D 2126.
 - TEST REPORT ON SURFACE BURNING CHARACTERISTICS UNDER ASTM E 84 FOR ACROCRETE PRE-APPLIED BASE COAT, GLOTEX CORPORATION TESTING SERVICES, MTS JOB NO. 520228.
 - ENGINEERING FIRE INVESTIGATION BY WALKER ENGINEERING, INC.

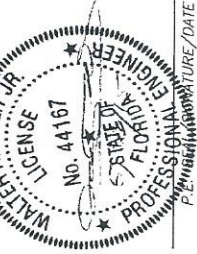

Warning note:
Attention Building Official / Building Inspector:
An "original signed and company sealed letter" from Wellbilt International is required proving that the panels were purchased from them in order for this NOA to be valid on any job.

APPLICATION SEQUENCE:

1. SPREAD 6-8 MIL OF ACRYLIC EMULSION TO BOND THE 22 GAUGE GALVANIZED STEEL SKIN (ALREADY ATTACHED TO WALL PANEL STEEL FRAME) TO THE PERMABASE™ CEMENT BOARD CONSTITUTING THE SURE-BOARD® SYSTEM.

2. USE (3) #10x3/4" S.M.S. LOCATED AT 2 1/4" FROM END, 8", 13" 1/2", 14", 7 1/2" TO SECURE PERMABASE™ CEMENT BOARD TO HORIZONTAL TOP AND BOTTOM SLIP TRACK AND USE (17) #10x1 1/2" S.M.S. STARTING AT 6" FROM BOTTOM AT 6" o.c. Max. TO SECURE PERMABASE™ CEMENT BOARD TO 20 GAUGE GALVANIZED STEEL VERTICAL STUDS SPACED AT 16" o.c. Max.

3. APPLY ACROPROY AND EMBED 9 1/4" WIDE FIBERGLASS MESH INTO THE WET ACROPROY OVER EVERY JOINT BETWEEN PANELS AND PANEL EDGE AROUND DOORS AND WINDOWS. A PERIOD OF 24 HOURS SHALL LAPSE BETWEEN THE INSTALLATION OF THE JOINT MESH AND THE ACROPROY LEVELING COAT.

4. APPLY ACROPROY LEVELING COAT USING 1/2"x1/2" STAINLESS STEEL NOTCHED TROWEL WITH 1 1/2" SPACE BETWEEN NOTCHES TO THE ENTIRE SURFACE OF BOARD AT A UNIFORM THICKNESS. A PERIOD OF 24 HOURS SHALL LAPSE BEFORE INSTALLING THE FINISH COAT.

5. FINISH WALL USING A STAINLESS STEEL TROWEL, APPLY AND LEAVE A COAT OF TROWEL FINISHES EFFECT OR SAND EFFECT TO A UNIFORM THICKNESS, APPROXIMATELY 1 TO 1 1/2 TIMES THE LARGEST AGGREGATE. THE TEXTURE IS ACHIEVED BY UNIFORM HAND MOTION AND TYPE OF TOOL USED. MAINTAIN WET EDGE FOR UNIFORMITY OF COLOR AND TEXTURE. A TIGHT COAT OF ACROCRETE ACROFINISH SHALL BE APPLIED CONTINUOUSLY TO A THICKNESS NOT GREATER THAN THE LARGEST AGGREGATES. A WET EDGE SHALL BE MAINTAINED. LEVELING AND TEXTURING SHALL TAKE PLACE IN ONE OPERATION. ACROFINISH DRYING TIME IS 24 HOURS. OVERALL METRAGE THICKNESS OF ACROCRETE DA SYSTEM IS 3/16".

6. TO REDUCE THE RISK OF DAMAGING WATER SENSITIVE SHEATHING OR FRAMING, ALL WINDOW AND DOOR OPENINGS MUST BE PROPERLY FLASHED AND WATERPROOFED AND INCIDENTAL WATER SHALL BE ALLOWED TO ESCAPE. PLEASE REFER TO SHEET 3 OF 10 FOR TYP.

7. SEALING DETAIL AT JOINT BETWEEN PANELS AND SHEET 10 OF 10 FOR TYP. SEALING DETAIL AT BOTTOM OF PANEL. FOLLOW WINDOW AND DOOR MANUFACTURERS RECOMMENDATIONS FOR PROPER INSTALLATION. SEALING DETAILS ON SHEET 9 OF 10 ARE TYPICAL AND SHOULD BE INTENT TO PREVENT WATER INFILTRATION INTO AND BEHIND THE SYSTEM. SEE CORNER DETAIL ON SHEET 10 OF 10. ALTERNATE DETAILS AND SPECIFIC CONDITIONS NOT COVERED BY THE TYPICAL DETAILS ARE THE RESPONSIBILITY OF THE LICENSED DESIGN PROFESSIONAL OF RECORD FOR THE BUILDING WHERE THIS SYSTEM WILL BE USED, IN CONSULTATION WITH WELBILT INTERNATIONAL, INC.

8. TEMPORARY PROTECTION SHALL BE PROVIDED AT ALL TIMES UNTIL BASE COAT, FINISH, AND PERMANENT FLASHINGS, SEALANT, ETC. TO PROTECT THE WALL FROM WEATHER AND OTHER DAMAGE. SEALANT AND FLASHINGS SHALL BE INSTALLED PROMPTLY.

9. GLASS FIBER OR SAFE BLANKET INSULATION MAY BE INSERTED IN THE WALL CAVITY FOR BETTER THERMAL AND SOUND PERFORMANCE.

10. THE MANUFACTURER'S PUBLISHED INSTALLATION INSTRUCTIONS AND THIS DRAWING SHALL BE STRICTLY ADHERED TO AND A COPY OF THESE INSTRUCTIONS SHALL BE AVAILABLE AT ALL TIMES ON THE JOB SITE DURING INSTALLATION.

11. THE INSTRUCTIONS WITHIN THIS DRAWING GOVERN IF THERE ARE ANY CONFLICTS BETWEEN THE MANUFACTURER'S INSTRUCTIONS AND THIS DRAWING.

PRODUCT REVISED as complying with the Florida Building Code. A revision to the Florida Building Code is effective on 11/27/2019. By *Heather H. Tillitt* Miami Dade Product Control

MIAMI DADE COUNTY

FLORIDA BUILDING CODE (High Velocity Hurricane Zone)

SURE-BOARD® WALL PANEL		F.R.L. DRAWN BY	05/22/15	DATE
WELLBILT INTERNATIONAL CORP.		PHONE: (305) 884-8020	FAX: (305) 884-8029	DRAWING No
14030 N.W. B2 AVE MIAMI LAKES, FL 33016		REV. No	REV. No	DATE
REV. No	DESCRIPTION	DATE	REV. No	DESCRIPTION
1	OLD 13-089	05/22/15	3	
2			4	

© 2015 TILTECO INC.

TILTECO INC.

TILIT TESTING & ENGINEERING COMPANY
6355 N.W. 36th St., Ste. 305, VIRGINIA GARDENS, FL 33166
Phone : (305)871-1530 • Fax : (305)871-1531
e-mail: tilteco@aol.com

WALTER A. TILLITT JR., P.E.
FLORIDA Lic. # 44167

FLORIDA BUILDING CODE (High Velocity Hurricane Zone)	MIAMI DADE COUNTY
--	-------------------

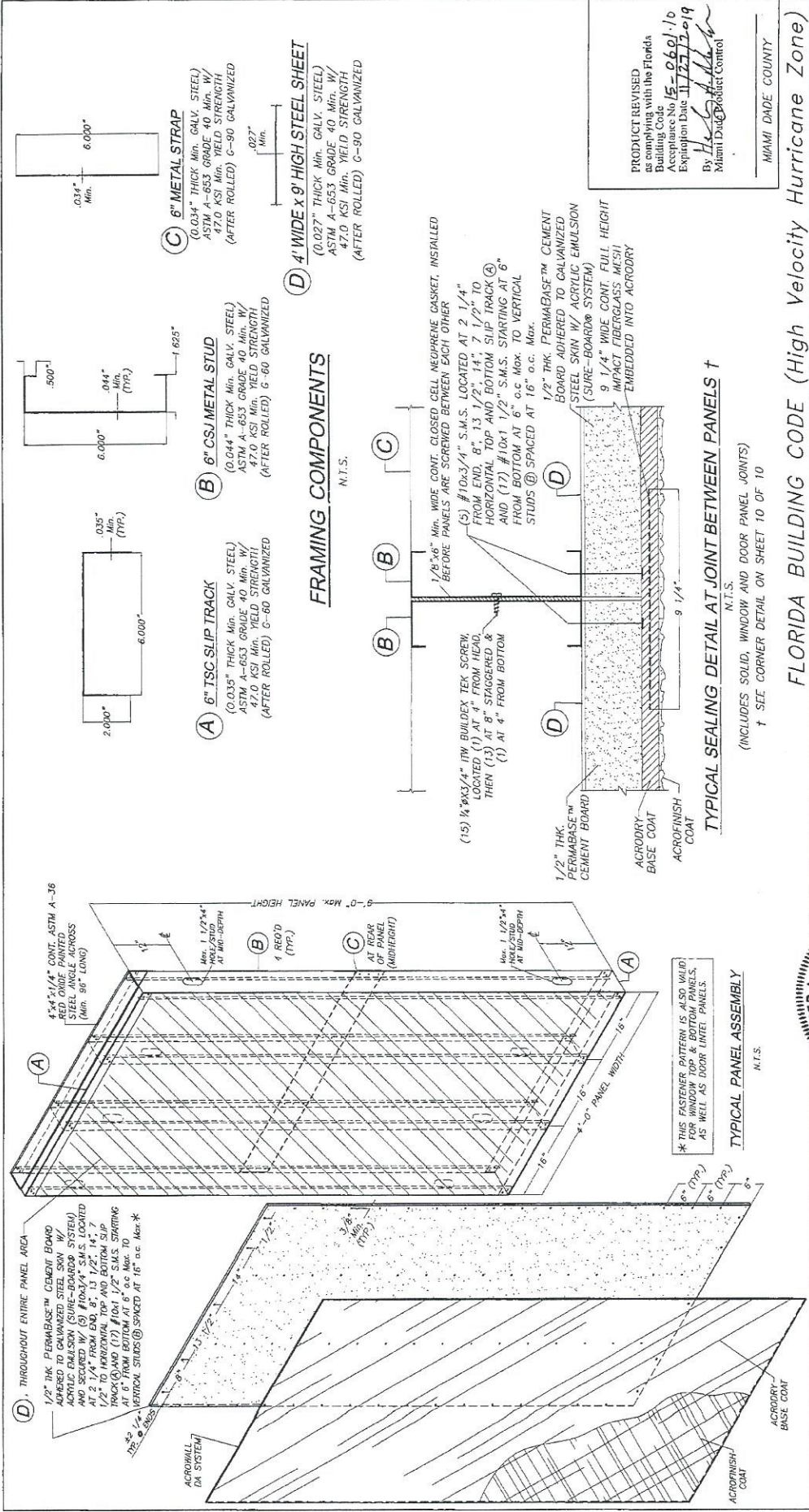

FLORIDA BUILDING CODE (High Velocity Hurricane Zone)

SURE-BOARD® WALL PANEL

WELLBIT INTERNATIONAL CORP.
 14030 N.W. 82 AVE
 MIAMI LAKES, FL 33016
 PHONE: (305) 884-8020 FAX: (305) 884-8029

TILECO INC.
 © 2015 TILECO INC.
 TILLIT TESTING & ENGINEERING COMPANY
 6355 N.W. 36th, Ste. 305, VIRGINIA GARDENS, FL 33166
 Phone: (305) 971-1530 Fax: (305) 971-1531
 6-month license # 00006719
 WALTER A. TILLIT, Jr., P.E.
 FLORIDA Lic. # 44167

Warning note:
 Attention Building Official / Building Inspector.
 An "original signed and company sealed letter" from Wellbit International is required proving that the panels were purchased from them in order for this NOA to be valid on any job.

PROFIT REVIEWED
 as complying with the Florida Building Code
 Acceptance No. **15-060110**
 Expiration Date **11-23-19**
 By: *[Signature]*
 Miami District Product Control

MIAMI DADE COUNTY

F.R.L. DRAWN BY	05/22/15	DATE
15-149	15-149	DRAWING No
REVISIONS	DATE	REV. No
1	05/22/15	3
2	05/22/15	4

SHEET 3 OF 10

SEE NOTE 8 ON SHEET 1 OF 10 FOR ROOF CONNECTION SPECS

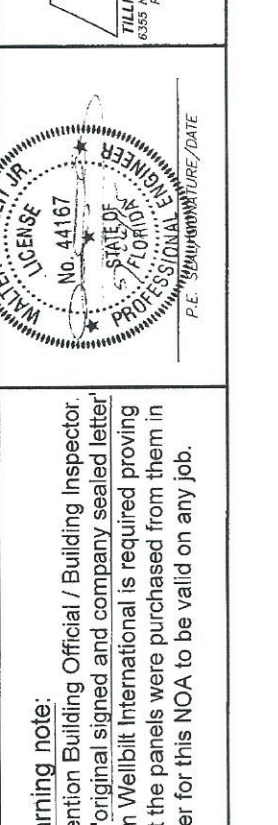
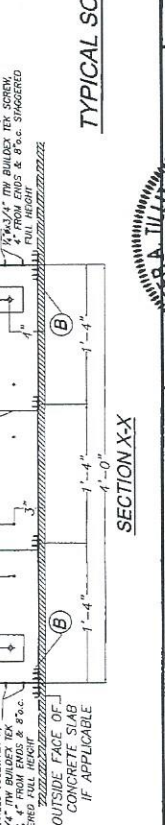
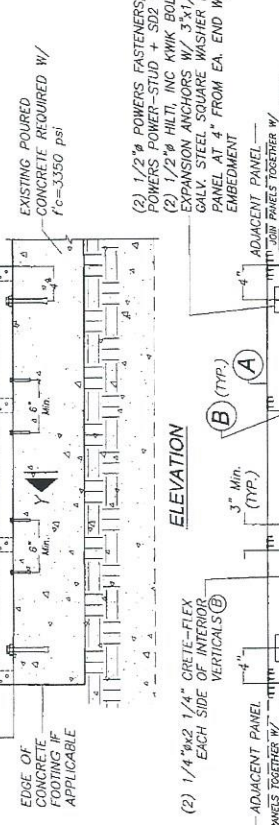
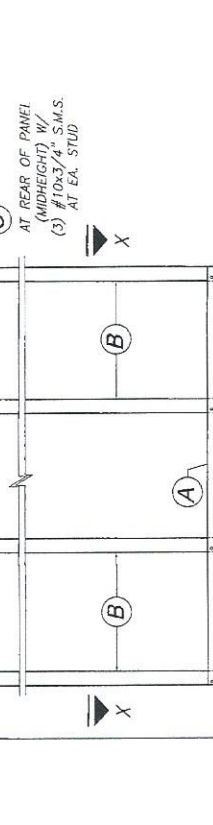
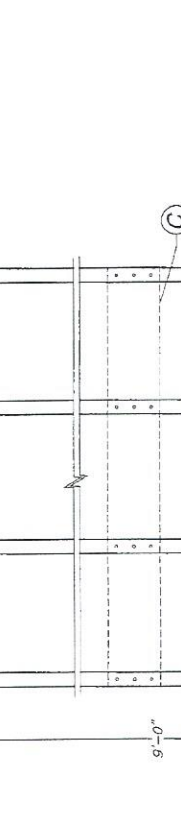
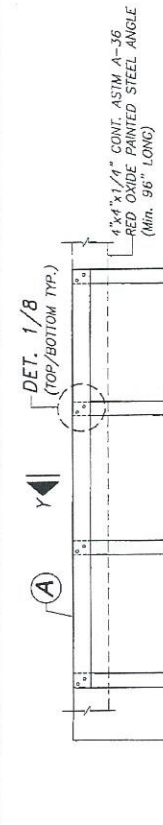

4x4x1/4" CONT. ASTM A-36 RED OXIDE PAINTED STEEL ANGLE (Min. 96" LONG)

AT REAR OF PANEL (MIDHEIGHT) W/ (3) #10x3/4" S.M.S. AT EA. STUD

EXISTING POURED CONCRETE REQUIRED W/ f'c=3350 psi

(2) 1/4" x 1/4" CREIE-FLEX VERTICALS EACH SIDE OF INTERIOR

ADJACENT PANEL TO BE FASTENED TOGETHER W/ 1/4" x 1/4" x 1/4" THIN BUILDUP KEY SCREW, 2" FROM ENDS & 8" O.C. STAGGERED

EXISTING POURED CONCRETE REQUIRED W/ f'c=3350 psi

2'-0" Max. O.H. ALLOWED

AT REAR OF PANEL (MIDHEIGHT) W/ (3) #10x3/4" S.M.S. AT EA. STUD

EXISTING POURED CONCRETE REQUIRED W/ f'c=3350 psi

(2) 1/2" POWER FASTENERS, INC. POWERS POWER-STUD + SD2 OR (2) 1/2" HILTI, INC KWIK BOLT TZ EXPANSION ANCHORS W/ 3"x1/4" THK. GALV. STEEL SQUARE WASHER FOR EA. PANEL AT 4" FROM EA. END W/ 5" Min. EMBEDMENT

ADJACENT PANEL TO BE FASTENED TOGETHER W/ 1/4" x 1/4" x 1/4" THIN BUILDUP KEY SCREW, 2" FROM ENDS & 8" O.C. STAGGERED

EXISTING POURED CONCRETE REQUIRED W/ f'c=3350 psi

DET. 1/B (TOP/BOTTOM TYP.)

DET. 2/B (TOP, TOP)

DET. 3/10

SECTION Y-Y

SECTION X-X

WALLER A. TILIT, JR., P.E. LICENSE No. 44167 STATE OF FLORIDA PROFESSIONAL ENGINEER

PRODUCT REVISED as complying with the Florida Building Code Acceptance No 15-060, 10 Expiration Date 11/27/2019 By He [Signature] Miami Dade Product Control

MIAMI DADE COUNTY

FLORIDA BUILDING CODE (High Velocity Hurricane Zone)

SURE-BOARD® WALL PANEL

WELLBILT INTERNATIONAL CORP. 14030 N.W. 82 AVE MIAMI LAKES, FL 33016 PHONE: (305) 884-8020 FAX: (305) 884-8029

REV. No	DATE	REV. No	DESCRIPTION
1	05/22/15	3	OLD 13-089
2		4	

WALTER A. TILIT, JR., P.E. LICENSE No. 44167 STATE OF FLORIDA PROFESSIONAL ENGINEER

Warning note: Attention Building Official / Building Inspector. An 'original signed and company sealed letter' from Wellbilt International is required proving that the panels were purchased from them in order for this NOA to be valid on any job.

FLORIDA LIC. # 44167

SHEET 4 OF 10

SEE NOTE 8 ON SHEET 1 OF 10 FOR ROOF CONNECTION SPECS

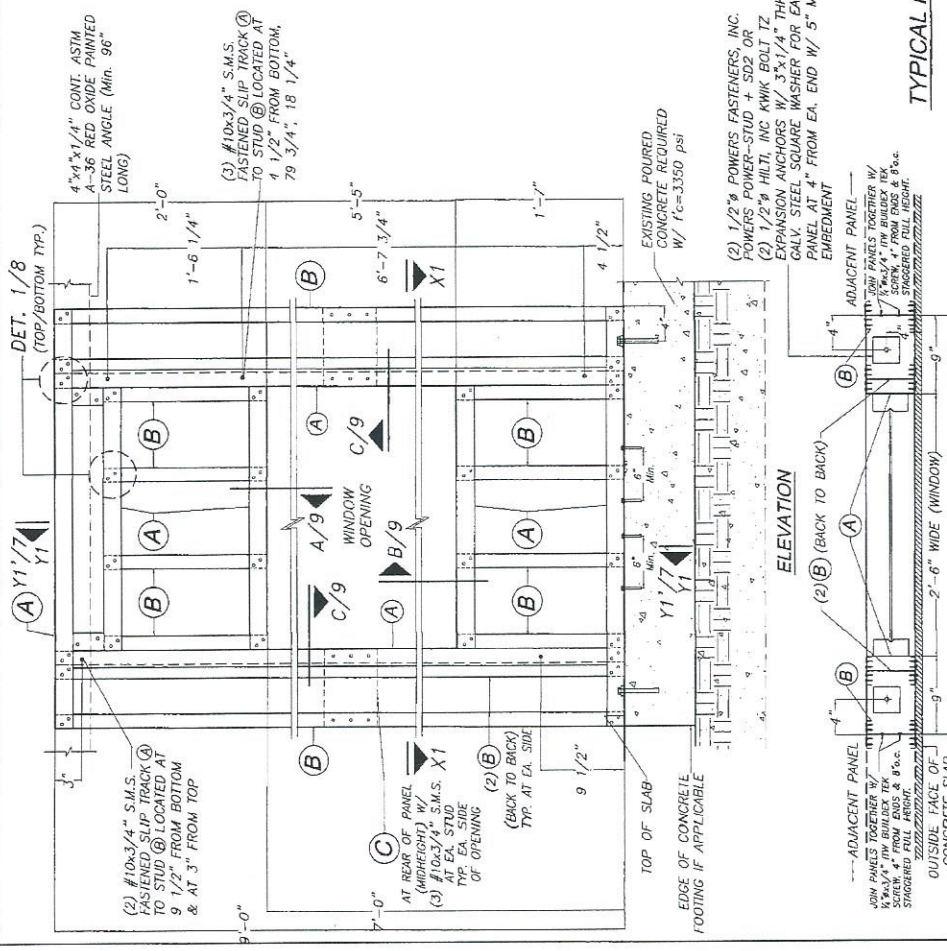
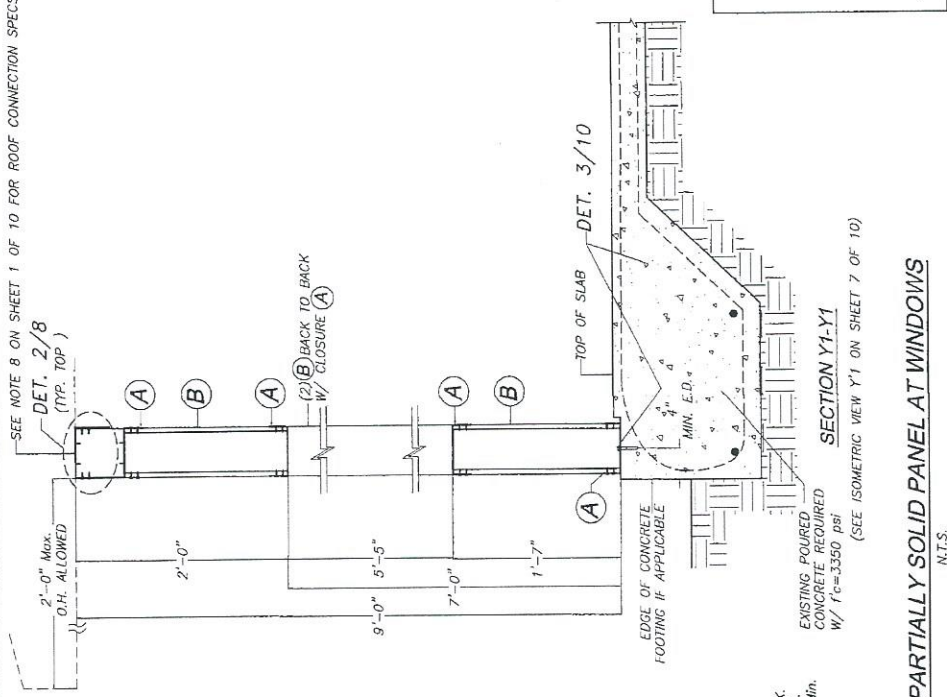

PRODUCT REVISED
 in compliance with the Florida
 Building Code
 Acceptance No. 15-0601-10
 Expiration Date 11/27/2019
 By *[Signature]*
 Miami Data Products Control

MIAMI DADE COUNTY

TYPICAL PARTIALLY SOLID PANEL AT WINDOWS

FLORIDA BUILDING CODE (High Velocity Hurricane Zone)

SURE-BOARD® WALL PANEL

WELLBILT INTERNATIONAL CORP.
 14030 N.W. 82 AVE
 MIAMI LAKES, FL 33016
 PHONE: (305) 884-8020 FAX: (305) 884-8029

TILECO INC.
 TILIT TESTING & ENGINEERING COMPANY
 6355 N.W. 36th St., Ste. 305, VIRGINIA GARDENS, FL 33166
 Phone: (305) 871-1550 Fax: (305) 871-1531

WALTER TILIT, JR. P.E.
 LICENSE NO. 44167
 PROFESSIONAL ENGINEER
 STATE OF FLORIDA

Warning note:
 Attention Building Official / Building Inspector.
 An 'original signed and company sealed letter'
 from Wellbilt International is required proving
 that the panels were purchased from them in
 order for this NOA to be valid on any job.

F.R.L.
 DRAWN BY
 05/22/15
 DATE

15-149
 DRAWING NO

REV. No.	DATE	REV. No.	DESCRIPTION
1	01.0 13-089	3	
2	05/22/15	4	

© 2015 TILECO INC.

WALTER TILIT, JR. P.E.
 LICENSE NO. 44167
 PROFESSIONAL ENGINEER
 STATE OF FLORIDA

SHEET 5 OF 10

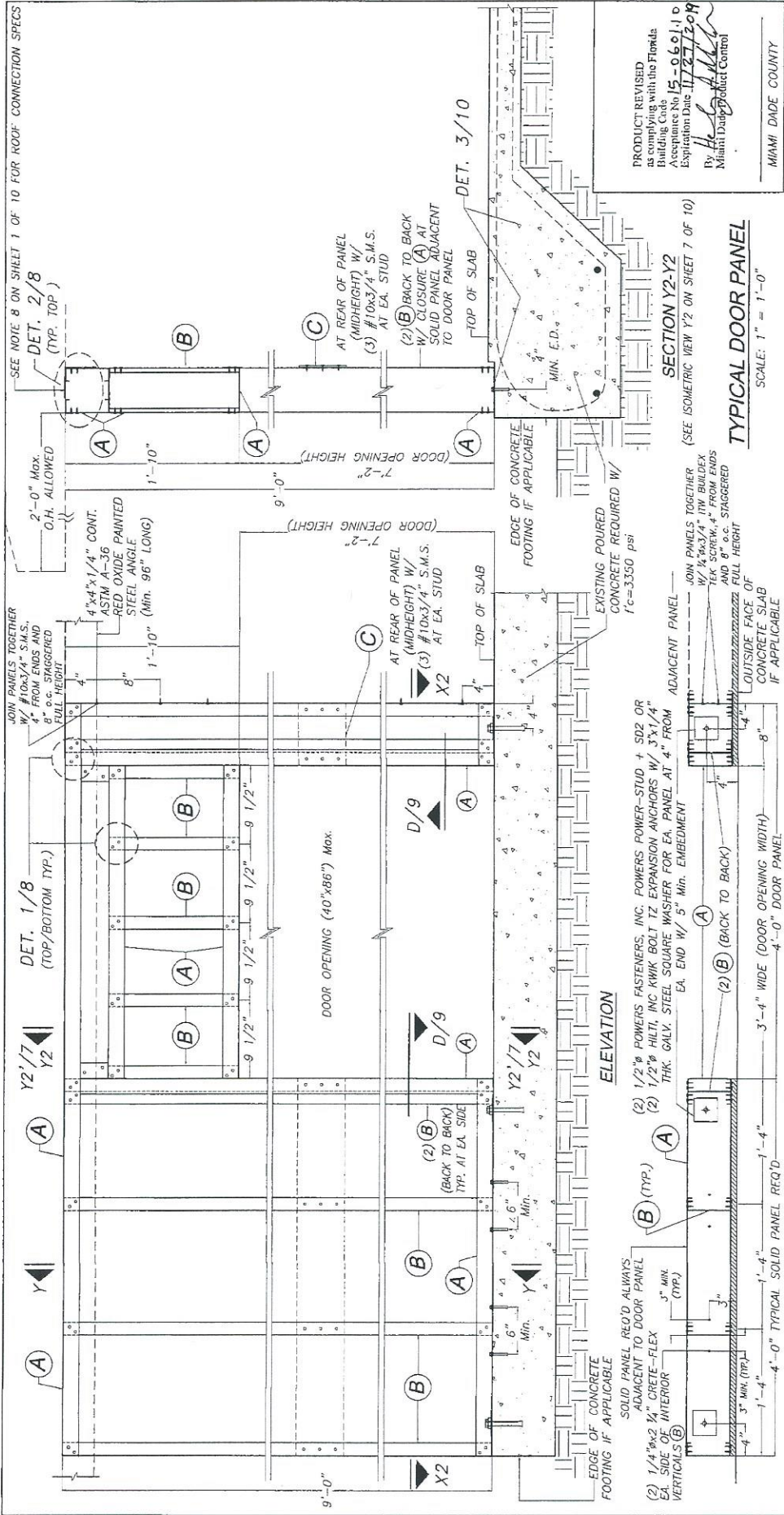

FLORIDA BUILDING CODE (High Velocity Hurricane Zone)

SURE-BOARD® WALL PANEL

F.R.L. DRAWN BY
05/22/15 DATE

WELLBILT INTERNATIONAL CORP.
14030 N.W. 82 AVE
MIAMI LAKES, FL 33016
PHONE: (305) 884-8020 FAX: (305) 884-8029

TILECO INC.
© 2015 TILECO INC.

TILECO INC.
TILIT TESTING & ENGINEERING COMPANY
605 W. WILSON ST.
MIAMI, FL 33136
Phone: (305) 971-1530 Fax: (305) 971-1531
e-mail: tileco@aol.com

WALTER A. TILIT JR.
LICENSED PROFESSIONAL ENGINEER
No. 44187
STATE OF FLORIDA
P.E. SPANISH HAVEN/DATE

Warning note:
Attention Building Official / Building Inspector.
An 'original signed and company sealed letter' from Wellbilt International is required proving that the panels were purchased from them in order for this NOA to be valid on any job.

15-149 DRAWING No
05/22/15 DATE
SHEET 6 OF 10

PRODUCT REVISED
as complying with the Florida
Building Code
As Amended
Effective Date 11/27/2010
By Heide Dwyer
Miami Dade Product Control

SECTION Y2-Y2
(SEE ISOMETRIC VIEW Y2 ON SHEET 7 OF 10)

TYPICAL DOOR PANEL
SCALE: 1" = 1'-0"

SECTION X2-X2
3'-4" WIDE (DOOR OPENING WIDTH)
1'-4" DOOR PANEL

FLORIDA BUILDING CODE (High Velocity Hurricane Zone)

SEE WINDOW AND DOOR FRAME CONNECTION
DETAIL TO PANEL FRAME ON SHEET 9 OF 10

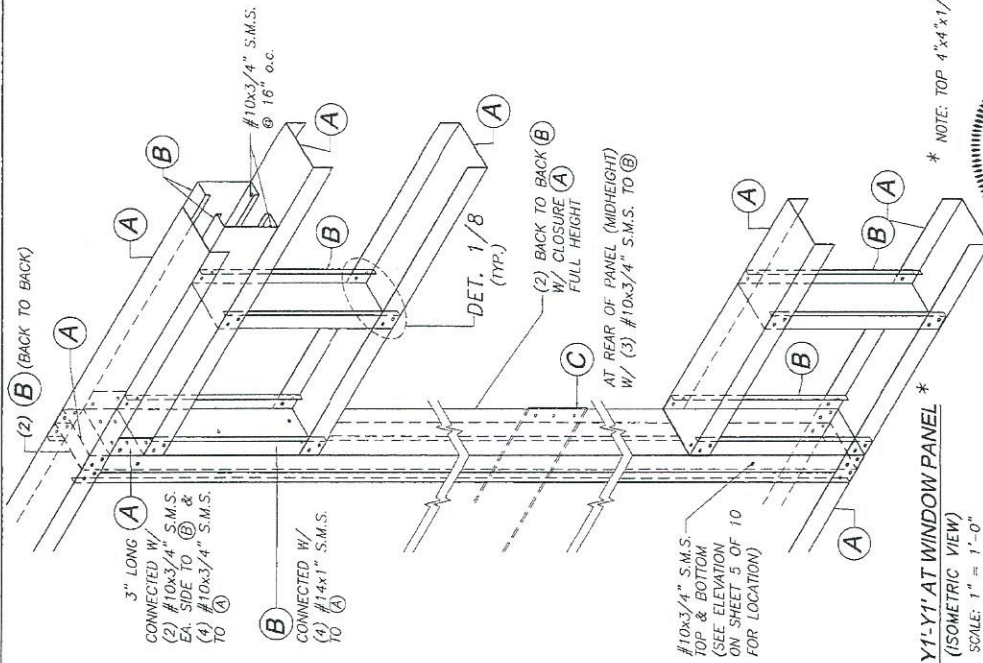
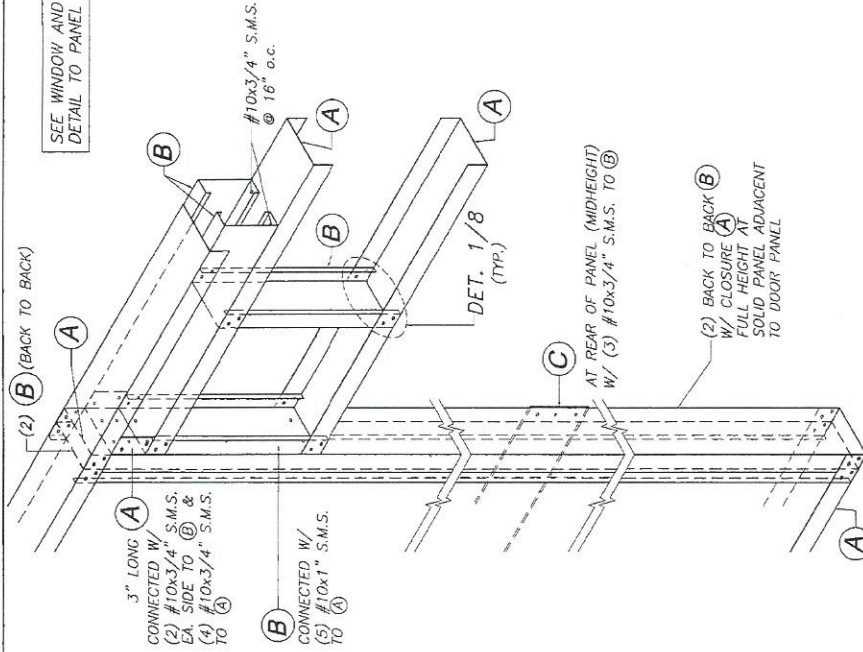

SECTION Y1-Y1 AT WINDOW PANEL *
(ISOMETRIC VIEW)
SCALE: 1" = 1'-0"

SECTION Y2-Y2 AT DOOR PANEL *
(ISOMETRIC VIEW)
SCALE: 1" = 1'-0"

* NOTE: TOP 4"x4"x1/4" TOP STRUT. ANGLE NOT SHOWN FOR CLARITY
(SEE DETAIL 2/9)

PRODUCT REVISED
as complying with the Florida
Building Code
Acceptance No. 15-0601-10
Expiration Date 11/23/2019
By *Heidi H. Hill*
Miami Trade Product Control

MIAMI DADE COUNTY

FLORIDA BUILDING CODE (High Velocity Hurricane Zone)

F.R.L. DRAWN BY	05/22/15 DATE
15-149 DRAWING No	SHEET 7 OF 10

REV. No	DATE	REV. No	DESCRIPTION
1	05/22/15	3	
2		4	

TILECO INC.
© 2015 TILECO INC.

TILLIT TESTING & ENGINEERING COMPANY
14030 N.W. 82 AVE
MIAMI LAKES, FL 33016
PHONE: (305) 884-8020 FAX: (305) 884-8029
e-mail: tillitco@aol.com

WALTER A. TILLIT JR., P.E.
FLORIDA LIC. # 44167

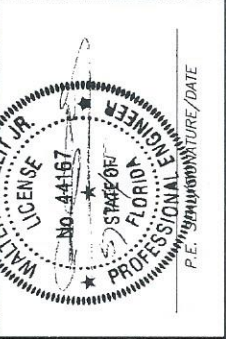

Warning note:
Attention Building Official / Building Inspector.
An 'original signed and company sealed letter'
from Wellbilt International is required proving
that the panels were purchased from them in
order for this NOA to be valid on any job.

14030 N.W. 82 AVE MIAMI LAKES, FL 33016 PHONE: (305) 884-8020 FAX: (305) 884-8029 e-mail: tillitco@aol.com

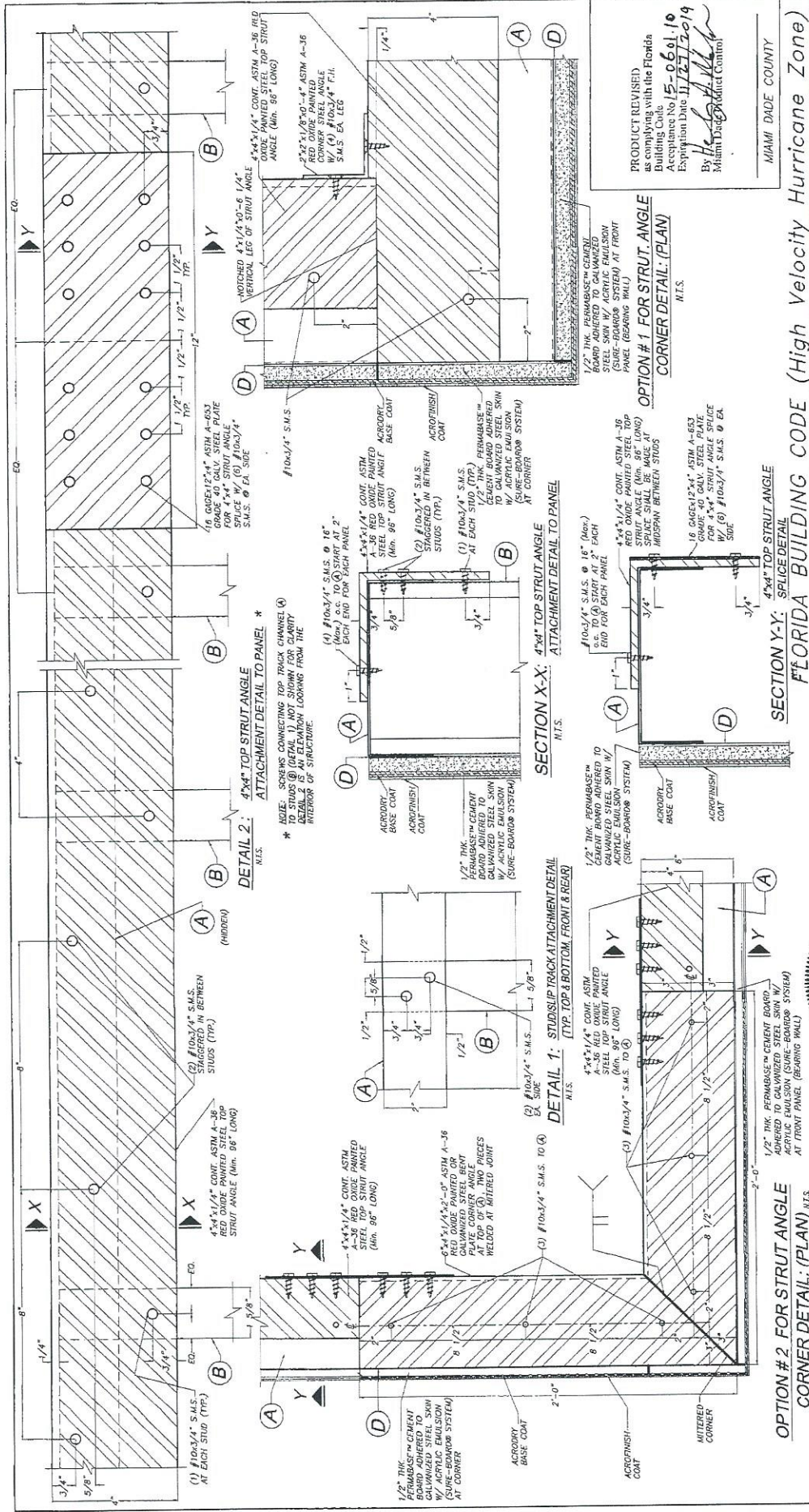

F.R.L.
DRAWN BY
05/22/15
DATE

SURE-BOARD® WALL PANEL

WELLBILT INTERNATIONAL CORP.
14030 N.W. 82 AVE
MIAMI LAKES, FL 33016
PHONE: (305) 884-8020 FAX: (305) 884-8029

REV. No	DESCRIPTION	DATE	REV. No	DESCRIPTION	DATE
1	OLD 13-009	05/28/12	3		
2			4		

15-149
DRAWING No

SHEET 8 OF 10

© 2015 TILTECO INC.

TILECO INC.

TILIT TESTING & ENGINEERING COMPANY
5635 N.W. 36th, Suite 1330, Virginia Beach, VA 23462
Phone: (757) 637-1330, (757) 637-1331
e-mail: tiliteco@tiliteco.com

WALTER A. TILIT JR., P.E.
FLORIDA Lic. # 44167



Warning note:
Attention Building Official / Building Inspector.
An "original signed and company sealed letter" from Wellbilt International is required proving that the panels were purchased from them in order for this NOA to be valid on any job.

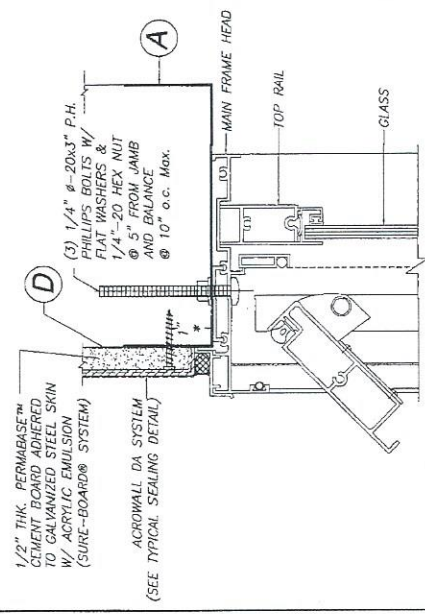

SECTION A: WINDOW HEAD CONNECTION TO PANEL
SCALE 3/8" = 1"

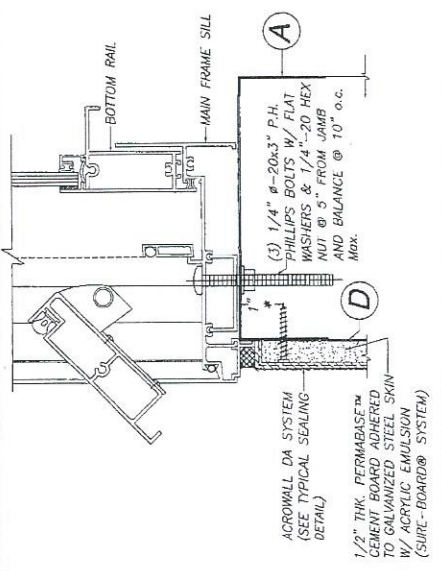

SECTION B: WINDOW SILL CONNECTION TO PANEL
SCALE 3/8" = 1"

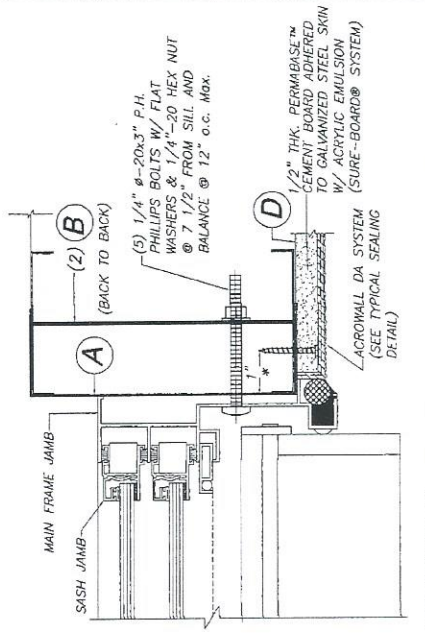

SECTION C: WINDOW JAMB CONNECTION TO PANEL
SCALE 3/8" = 1"

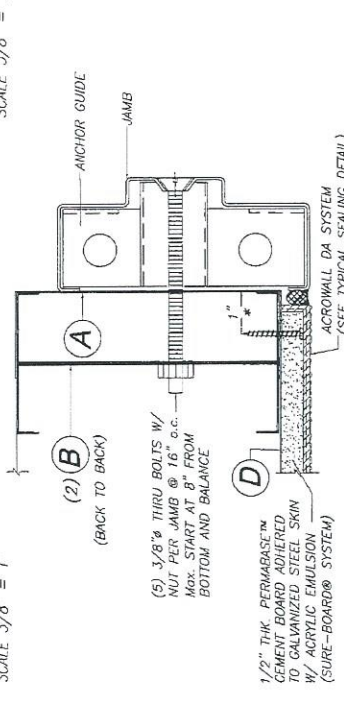

SECTION D: DOOR JAMB CONNECTION TO PANEL
SCALE 3/8" = 1"

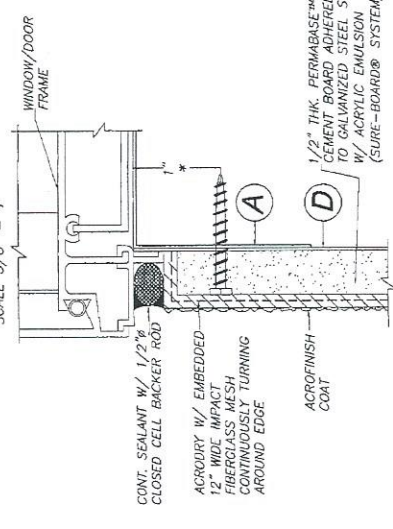

TYPICAL SEALING DETAIL
N.T.S.

PRODUCT REVISIED as complying with the Florida Building Code
Acceptance No. 15-060110
Expiration Date 11/27/2019
By: [Signature]
Miami-Dade Building Control

MIAMI DADE COUNTY
FLORIDA BUILDING CODE (High Velocity Hurricane Zone)

Warning note:
Attention Building Official / Building Inspector.
An 'original signed and company sealed letter' from Wellbilt International is required proving that the panels were purchased from them in order for this NOA to be valid on any job.

© 2015 TILTECO INC.

TILTECO INC.
TILLIT TESTING & ENGINEERING COMPANY
6355 N.W. 56th St. Ste. 305 VIRGINIA GARDENS, FL 33166
Phone: (305) 871-1530 Fax: (305) 871-1531
e-mail: tilteco@aol.com
ED-0006719
WALTER A. TILLIT Jr. P.E.
FLORIDA Lic. # 44167

PROFESSIONAL ENGINEER
STATE OF FLORIDA
LICENSE No. 44167
WALTER A. TILLIT Jr.
P.E. SEAL/SIGNATURE/DATE

WELLBILT INTERNATIONAL CORP.
14030 N.W. 82 AVE
MIAMI LAKES, FL 33016
PHONE: (305) 884-8020 FAX: (305) 884-8029

REV. No	DESCRIPTION	DATE	REV. No	DESCRIPTION	DATE
1	OLD 13-089	05/22/14	3		
2			4		

SURE-BOARD® WALL PANEL
F.R.L. DRAWN BY
05/22/15 DATE
15-149 DRAWING No
SHEET 9 OF 10

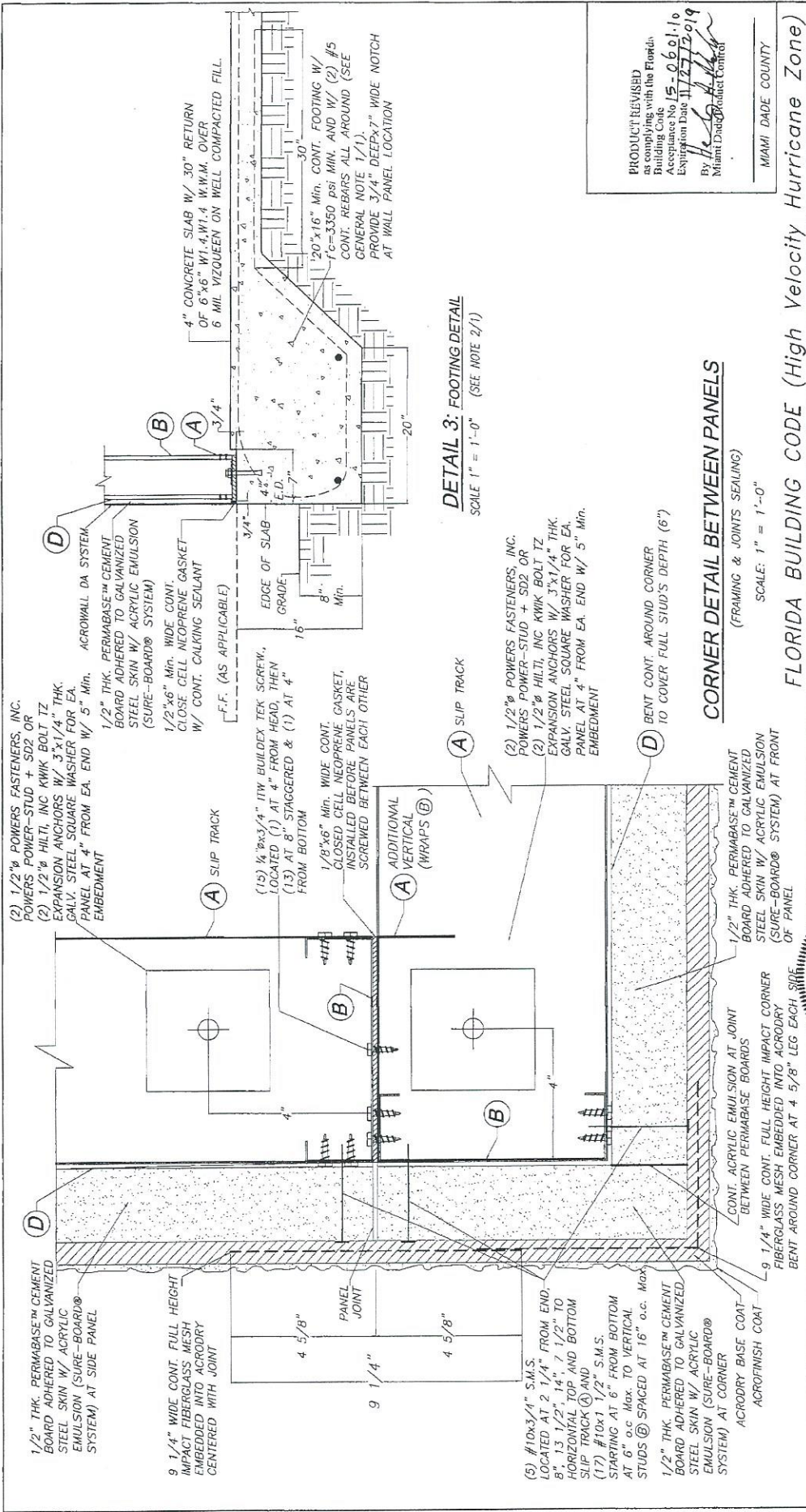

DETAIL 3: FOOTING DETAIL
SCALE 1" = 1'-0" (SEE NOTE 2/1)

CORNER DETAIL BETWEEN PANELS
(FRAMING & JOINTS SEALING)
SCALE: 1" = 1'-0"

PRODUCT REVISED
as complying with the Florida
Building Code
Acceptance No 15-060110
Expiration Date 11/27/2019
By: *[Signature]*
Miami District Product Control

MIAMI DADE COUNTY

F.R.L. DRAWN BY	05/22/15 DATE
SURE-BOARD® WALL PANEL	

WELLBILT INTERNATIONAL CORP.			
14030 N.W. 82 AVE MIAMI LAKES, FL 33016			
PHONE: (305) 884-8028 FAX: (305) 884-8029			
REV. No	DATE	REV. No	DATE
1	01/13/09	3	05/22/15
2		4	

© 2015 TILTECO INC.

TILTECO INC.

TILLIT TESTING & ENGINEERING COMPANY
6355 N.W. 36th St., Ste. 305, VIRGINIA GARDENS, FL 33166
Phone: (305) 871-1530 Fax: (305) 871-1531
e-mail: TTE@tilteco.com
EP-0006719
WALTER A. TILLIT, Jr., P.E.
FLORIDA Lic. # 44167

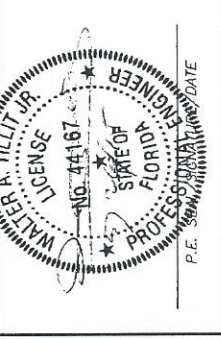

Warning note:
Attention Building Official / Building Inspector.
An 'original signed and company sealed letter'
from Wellbilt International is required proving
that the panels were purchased from them in
order for this NOA to be valid on any job.