

CT STUD, TABBED TRACK & JAMB TRACK

Marino\WARE created its CT Shaftwall System, to be a flexible shaftwall assembly that can accommodate any UL Classified gypsum liner board for maximum versatility in design, purchase, and construction. The Marino\WARE CT Shaftwall System is comprised of CT-Stud and Tabbled Track components, resulting in easier installation and fewer parts to inventory and purchase.

Features include:

- Fire rated
- Full range of sizes: 2 1/2", 4", and 6"
- 25, 20 and 18 gauges
- Multiple production locations
- Next day delivery options
- One-sided installation design



PHYSICAL PROPERTIES							SECTION PROPERTIES			
MODEL NO.	WEB	GAUGE	MIL	KSI	DESIGN (in)	COATING	WEIGHT (lb/ft)	AREA (in ²)	I _x (in ⁴)	S _x (in ³)
212CT25	2-1/2"	25	18	40	0.0188	G40	0.456	0.134	0.127	0.0939
212CT20	2-1/2"	20	33	40	0.0346	G40	0.833	0.245	0.226	0.166
400CT25	4"	25	18	40	0.0188	G40	0.552	0.162	0.387	0.185
400CT20	4"	20	33	40	0.0346	G40	1.010	0.297	0.695	0.331
400CT18	4"	18	43	40	0.0451	G60	1.310	0.385	0.892	0.424
600CT20	6"	20	33	40	0.0346	G40	1.250	0.366	1.850	0.598
600CT18	6"	18	43	40	0.0451	G60	1.620	0.475	2.380	0.770

Notes:

1. Tabbled Track and Jamb Track available in same size and gauge as CT studs
2. I_x = Moment of inertia
3. S_x = Section modulus
4. A = Sectional area

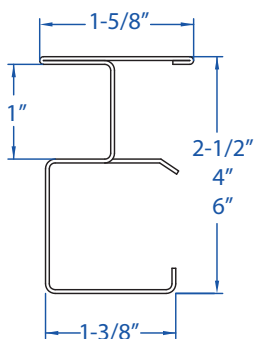

CT Stud

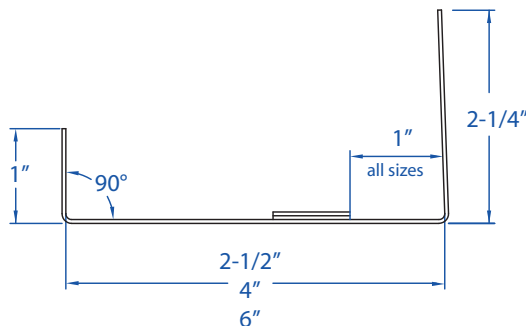

Tabbled Track

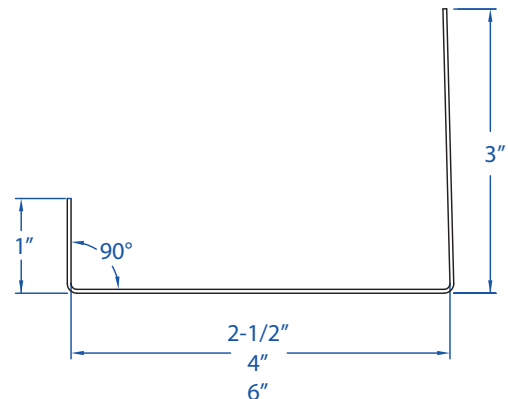

Jamb Track

For more information, please contact MarinoWARE® Technical Services at 866-545-1545.

This technical information reflects the most current information available and supersedes any and all previous publications effective March 20, 2019 | MW-Shaftwall_ASW_Catalog | © WARE Industries, Inc. 2019

CT STUD LIMITING HEIGHTS & HORIZONTAL SPANS

1 Hour Shaftwall System - limiting heights

DEPTH	GAUGE	DESIGN (in)	mil	5 PSF				7.5 PSF				10 PSF			
				L/120	L/180	L/240	L/360	L/120	L/180	L/240	L/360	L/120	L/180	L/240	L/360
2-1/2"	25	0.0188	18	13'-3"f	11'-11"	10'-10"	9'-5"	10'-10"f	10'-5"	9'-5"	8'-3"	9'-5"f	9'-5"	8'-7"	7'-6"
4"	25	0.0188	18	17'-6"f	15'-4"	13'-11"	12'-2"	14'-3"f	13'-5"	12'-2"	10'-8"	12'-4"f	12'-2"	11'-1"	9'-8"
2-1/2"	20	0.0346	33	17'-7"	15'-5"	14'-0"	12'-3"	15'-5"	13'-5"	12'-3"	10'-8"	13'-0"	12'-3"	11'-1"	9'-8"
4"	20	0.0346	33	21'-11"f	19'-3"	17'-6"	15'-3"	17'-11"f	16'-10"	15'-3"	13'-4"	15'-6"f	15'-3"	13'-11"	12'-2"
6"	20	0.0346	33	24'-6"f	24'-6"f	24'-6"f	22'-7"	20'-0"f	20'-0"f	20'-0"f	19'-9"	17'-4"f	17'-4"f	17'-4"f	17'-4"f
4"	18	0.0451	43	21'-11"f	19'-3"	17'-6"	15'-3"	17'-11"f	16'-10"	15'-3"	13'-4"	15'-6"f	15'-3"	13'-11"	12'-2"
6"	18	0.0451	43	28'-1"f	28'-1"f	27'-10"	24'-3"	22'-11"f	22'-11"f	22'-11"f	21'-3"	19'-10"f	19'-10"f	19'-10"f	19'-3"

2 Hour Shaftwall System - limiting heights

DEPTH	GAUGE	DESIGN (in)	MIL	5 PSF				7.5 PSF				10 PSF			
				L/120	L/180	L/240	L/360	L/120	L/180	L/240	L/360	L/120	L/180	L/240	L/360
2-1/2"	25	0.0188	18	14'-5"	12'-7"	11'-5"	10'-0"	12'-7"	11'-0"	10'-0"	8'-9"	11'-2"f	10'-0"	9'-1"	7'-11"
4"	25	0.0188	18	18'-6"	16'-2"	14'-8"	12'-10"	16'-0"f	14'-2"	12'-10"	11'-3"	13'-10"f	12'-10"	11'-8"	10'-2"
2-1/2"	20	0.0346	33	17'-0"	14'-10"	13'-6"	11'-9"	14'-10"	13'-0"	11'-9"	10'-4"	13'-6"	11'-9"	10'-9"	9'-4"
4"	20	0.0346	33	23'-8"	20'-8"	18'-9"	16'-5"	20'-8"	18'-1"	16'-5"	14'-4"	18'-9"	16'-5"	14'-11"	13'-0"
6"	20	0.0346	33	28'-10"f	28'-10"	26'-4"	23'-0"	23'-6"f	23'-6"	23'-0"	20'-1"	20'-5"f	20'-5"f	20'-5"f	18'-3"
4"	18	0.0451	43	23'-8"	20'-8"	18'-9"	16'-5"	20'-8"	18'-1"	16'-5"	14'-4"	18'-9"	16'-5"	14'-11"	13'-0"
6"	18	0.0451	43	30'-0"f	30'-0"f	28'-7"	25'-0"	24'-6"f	24'-6"f	24'-6"f	21'-10"	21'-2"f	21'-2"f	21'-2"f	19'-10"

2 Hour Stairwell System - limiting heights

DEPTH	GAUGE	DESIGN (in)	MIL	5 PSF				7.5 PSF				10 PSF			
				L/120	L/180	L/240	L/360	L/120	L/180	L/240	L/360	L/120	L/180	L/240	L/360
2-1/2"	25	0.0188	18	15'-7"	13'-8"	12'-5"	10'-10"	12'-9"	11'-11"	10'-10"	9'-5"	11'-0"f	10'-10"	9'-10"	8'-7"
4"	25	0.0188	18	17'-9"f	17'-6"	15'-11"	13'-11"	14'-6"f	14'-6"	13'-11"	12'-2"	12'-7"f	12'-7"f	12'-7"	11'-0"
2-1/2"	20	0.0346	33	19'-6"f	17'-5"	15'-10"	13'-10"	15'-11"f	15'-3"	13'-10"	12'-1"	13'-9"f	13'-9"f	12'-7"	11'-0"
4"	20	0.0346	33	22'-4"f	22'-4"f	20'-8"	18'-0"	18'-3"f	18'-3"	18'-0"	15'-9"	15'-9"f	15'-9"f	15'-9"	14'-4"
6"	20	0.0346	33	25'-1"f	25'-1"f	23'-5"	20'-6"	20'-5"f	20'-5"	20'-5"f	17'-11"	17'-9"f	17'-9"f	17'-9"	16'-3"
4"	18	0.0451	43	22'-4"f	22'-4"f	20'-8"	18'-0"	18'-3"f	18'-3"	18'-0"	15'-9"	15'-9"f	15'-9"f	15'-9"	14'-4"
6"	18	0.0451	43	28'-1"f	28'-1"f	26'-0"	22'-9"	22'-11"f	22'-11"f	22'-9"	19'-10"	19'-11"f	19'-11"f	19'-11"	18'-0"

Shaftwall Systems - Horizontal Spans (dead load only)

DEPTH	GAUGE	DESIGN (in)	mil	1 Hour				2 Hour			
				L/120	L/180	L/240	L/360	L/120	L/180	L/240	L/360
2-1/2"	25	0.0188	18	11'-7"f	10'-11"	9'-11"	8'-8"	12'-2"	10'-7"	9'-8"	8'-5"
2-1/2"	20	0.0346	33	15'-8"	13'-8"	12'-5"	10'-10"	13'-11"	12'-2"	11'-1"	9'-8"
4"	25	0.0188	18	15'-1"	14'-0"	12'-8"	11'-1"	14'-11"f	13'-7"	12'-4"	10'-9"
4"	20	0.0346	33	17'-11"	16'-10"	15'-3"	13'-4"	17'-6"f	16'-9"	15'-3"	13'-4"
6"	20	0.0346	33	19'-5"f	19'-5"f	19'-5"f	19'-5"f	18'-0"f	18'-0"f	18'-0"f	18'-0"
6"	18	0.0451	43	21'-7"f	21'-7"f	21'-7"f	20'-4"	18'-3"f	18'-3"f	18'-3"f	18'-3"f

Notes:

(F) Indicates flexure controls

24" o.c. only framing

Horizontal spans do not carry live loads, equipment, lighting or storage loads.

For more information, please contact MarinoWARE® Technical Services at 866-545-1545.

This technical information reflects the most current information available and supersedes any and all previous publications effective March 20, 2019 | MW-Shaftwall_ASW_Catalog | © WARE Industries, Inc. 2019

SHAFTWALL FIRE & SOUND RATING SUMMARIES

1 Hour Shaftwall Assembly

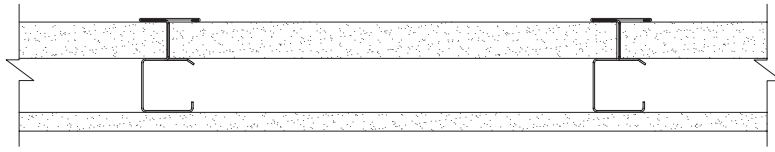

Test Reference:
Warnock-Hersey

Fire Components

- Any UL Classified 1" thick Liner Board Type X,
- MarinoWARE CT Stud and Tabbed Track
- Any UL Classified of one layer of 5/8" Type X or 1/2" Type C gypsum wallboard, oriented vertically.

Sound Rating (STC)

- 2 1/2" CT=38/41*
- 4" CT=41/47*
- 6" CT=44/48*

2 Hour Shaftwall Assembly

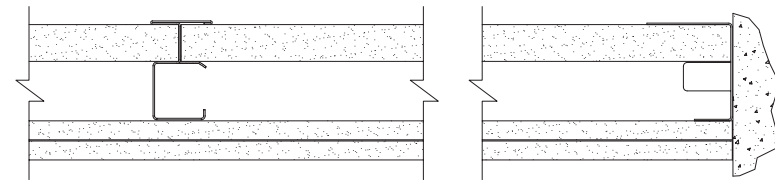

Test Reference:
Warnock-Hersey

Fire Components

- Any UL Classified 1" thick Liner Board Type X,
- MarinoWARE CT Stud and Tabbed Track
- Any UL Classified of two layers of 5/8" Type X or 1/2" Type C gypsum wallboard, oriented vertically.

Sound Rating (STC)

- 2-1/2" CT=40/45*
- 4" CT=45/49*
- 6" CT=45/50*

2 Hour Stairwall Assembly

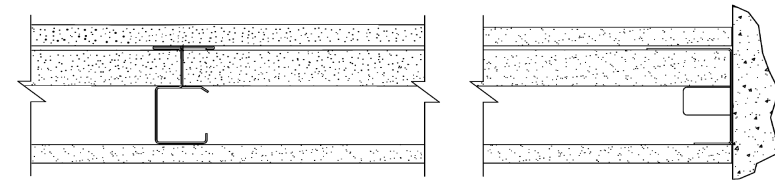

Test Reference:
Warnock-Hersey

Fire Components

- Any UL Classified 1" thick Liner Board Type X,
- MarinoWARE CT Stud and Tabbed Track
- Any UL Classified of two layers of 5/8" Type X or 1/2" Type C gypsum wallboard, oriented vertically.

Sound Rating (STC)

- 2-1/2" CT=40/45*
- 4" CT=45/49*
- 6" CT=45/50*

Notes:

* Represents the same assembly with the addition of 1-1/2" of blanket insulation installed in the cavity.

Generic UL Assemblies for CT Studs			NYC Approval
UL U417	UL U499	UL V473	CT Stud - MEA 148-05-M (2 Hours) CT Stud - MEA 148-05-M Vol. 2
UL U428	UL V451	UL V481	
UL U429	UL V455	UL V493	
UL U497	UL V470	UL V414	
UL U498	UL V472	UL V419	

SHAFTWALL INSTALLATION INSTRUCTIONS

1. Lay out per construction drawings. Secure Tabbed Track as perimeter framing on floor and plumb to ceiling and sides. Attach with suitable fasteners, spaced not more than 24" o.c.
2. Plan the stud layout 24" o.c. and adjust the spacing at either end so that the terminal stud will not fall closer than 8" from the end.
3. Erect the first 1" Liner Board panel, cut 3/4" less than the total height of the framed section. Plumb the panel flush against the web of the Tabbed Track and secure with 1-5/8" Type S screws 24" o.c. or bend out tabs in Tabbed Track to secure panels in place.
4. Insert a Marino\WARE CT Stud, cut 3/4" less than the overall height, into the top and bottom Tabbed Tracks and fit tightly over the previously installed 1" panel.
5. Install the next 1" Liner Board panel inside the Tabbed Tracks and within the tabs of the CT Stud. Note that the edges of the panel may be beveled to help guide the panel into the slotted and tabbed section of the stud.
6. Progressively install succeeding studs and panels as described above until the wall section is enclosed. The final panel section may be secured with 1-5/8" Type S screws or tabs from the Tabbed Track at 24" o.c.
7. For doors, ducts or other large penetrations or openings, install Jamb Track as perimeter framing. Use 20-gauge track with a 3" back leg for elevator doors and block cavity with 12" wide gypsum board filler strips when required by Door Frame Manufacturer.
8. 1" Liner Board panels may be abutted, spliced or stacked within the cavity. The shorter panel should be minimum 2" long or longer to engage two stud tabs on each panel edge. Joints of adjacent panels should be alternately stacked or staggered to prevent a continuous horizontal joint. NOTE: Warnock Hersey fire tests were conducted without back blocking of Liner Board joints.
9. Finished one side system. Install the first layer of 1/2" UL Classified gypsum board horizontally with 1" Type S or S-12 screws spaced 24" o.c. (5/8" Type X gypsum board may be used in lieu of 1/2" Type C gypsum board, if desired). The horizontal joints should be offset from any splice joints in the Liner Board panels by at least 12". The face layer may be installed either horizontally or vertically with 1-5/8" Type S or S-12 screws spaced 8" o.c. All edge and end joints should be offset from the base layer by 24" o.c.
10. Finished both sides system. Each side may be installed either horizontally or vertically with 1" Type S or S-12 screws spaced 8" o.c. Offset edges and ends on opposite sides 24" o.c.
11. When used as HVAC ducts, consult with HVAC engineer regarding level of caulking and sealant required. All joints on face layers are to be taped and finished and fasteners finished with joint compound meeting ASTM C 475. All penetration openings are to be filled with approved fire stopping sealants.

For more information, please contact Marino\WARE® Technical Services at 866-545-1545.

This technical information reflects the most current information available and supersedes any and all previous publications effective March 20, 2019 | MW-Shaftwall_ASW_Catalog | © WARE Industries, Inc. 2019

SHAFTWALL SYSTEMS SUGGESTED CONSTRUCTION DETAILS

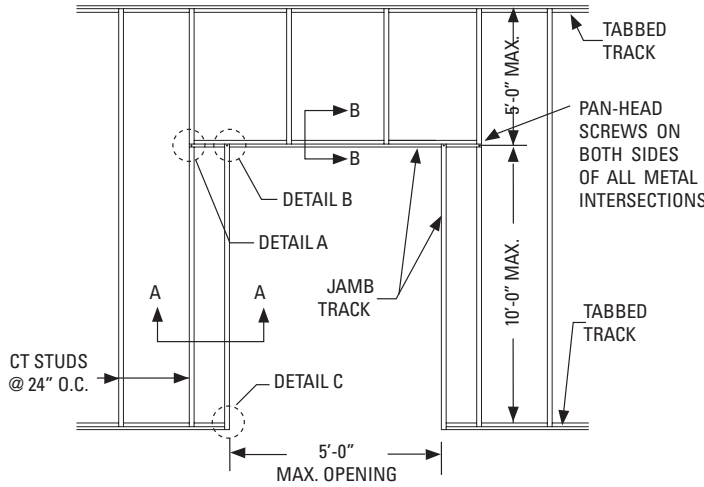

NOTES:
A.) FRAMING AT ELEVATOR DOOR SHALL BE MINIMUM 4" CT-STUDS AND RUNNERS 20 GAUGE.
B.) FOR DOOR GREATER THAN 5' WIDE AND 10' HIGH, IT NEEDS TO BE INVESTIGATED SEPARATELY.

1 Door Frame Elevation

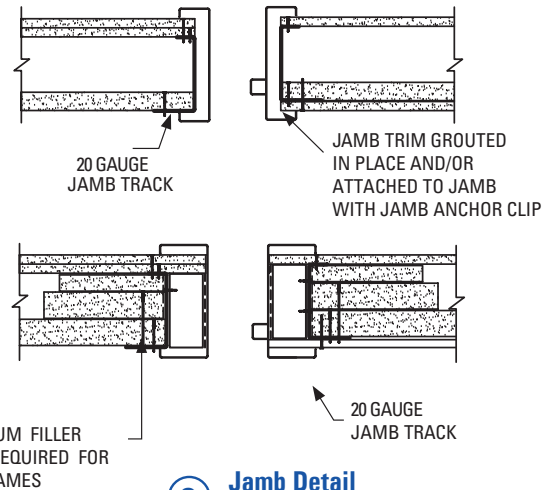

2 Jamb Detail Section A-A

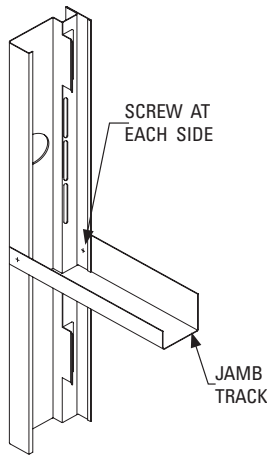

3 Header Detail Detail A

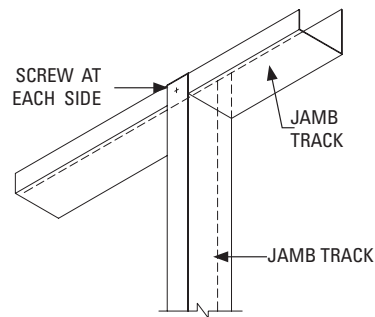

4 Header Detail Detail B

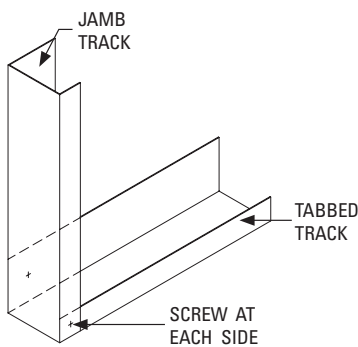

5 Jamb Detail Detail C

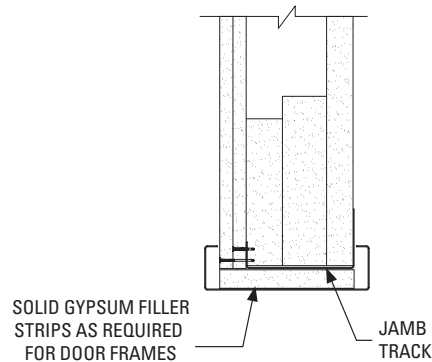

6 Header Detail Section B-B

For more information, please contact MarinoWARE® Technical Services at 866-545-1545.

This technical information reflects the most current information available and supersedes any and all previous publications effective March 20, 2019 | MW-Shaftwall_ASW_Catalog | © WARE Industries, Inc. 2019

SHAFTWALL SYSTEMS SUGGESTED CONSTRUCTION DETAILS

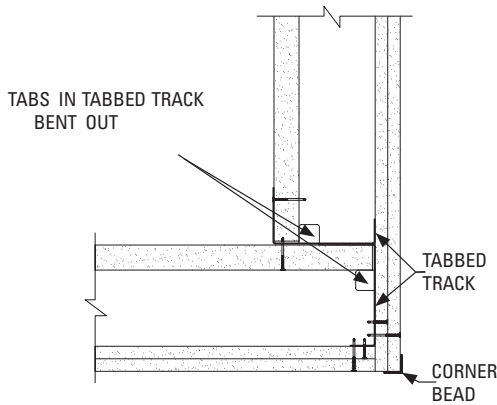

7 Outside Corner Detail

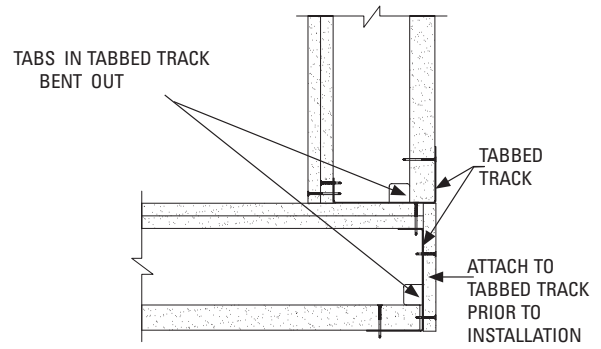

8 Inside Corner Detail

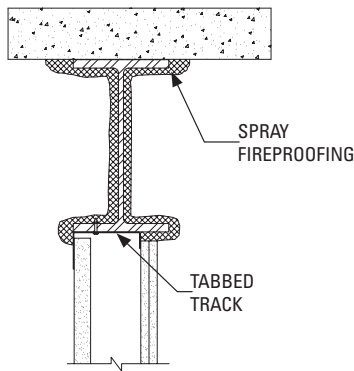

9 Steel Beam Detail

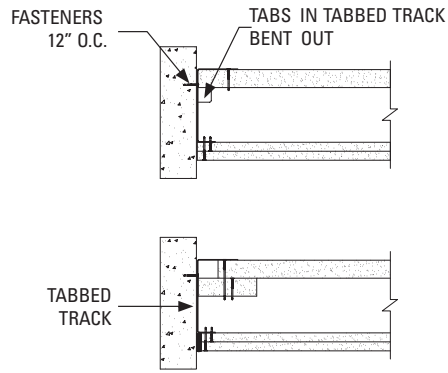

10 End of Wall Detail

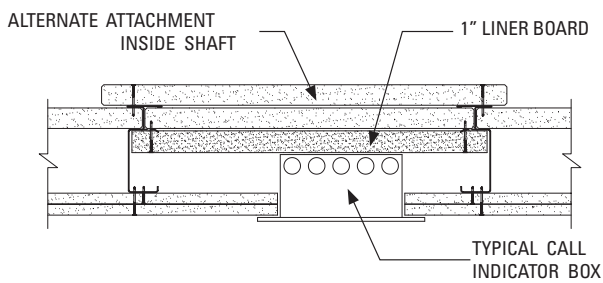

11 Call Box/Outlet Box/Mail Chute

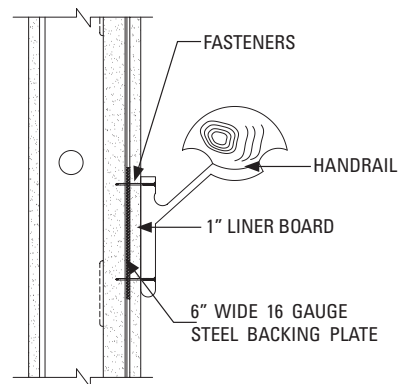

12 Handrail Connection