

## General Notes & Product Information

**Product profiles & details may vary by installation.**

**Consult architectural drawings, details & specifications before installation of any Marlite products.**

**Notice:** Statements expressed in this technical bulletin the recommendations for application of the Marlite brand products as outlined and illustrated under normal conditions of installation. The recommendations provided represent our best judgement, base on our experience with normal applications. Unless prior approval is obtained in writing from Marlite, deviation from these recommendations shall be at the sole risk of the installer(s).

**Preparation:** Building must be closed and HVAC systems operational and balanced. Concrete, paint, drywall compounds and other sources of humidity must be dry and cured. Structural walls must be flat & true. A subwall surface is recommended, such as drywall, plywood or OSB. Vapor barriers are required between wall framing and subwall surface for exterior walls, to discourage warping. Direct, repetitive and continuous exposure to HVAC ventilation, extreme temperatures and/or direct sun exposure can result in a detrimental effect to the panels. Such conditions should be corrected before product installation. Except as approved by the manufacturer, most Marlite products should not be installed in high-humidity areas, such as kitchens, restrooms, showers & cold storage areas. Protect exposed floor & wall areas from damage with drop-cloths & rigid cardboard or plywood.

**Conditioning:** Panels must be allowed to equalize to the building conditions before installation. Acclimation in the installation area of at least 48 hr. is recommended. To ensure product performance, temp range of 60-80° F and humidity range of 35-55% is recommended during storage, installation and product life cycle.

**Handling:** Open cartons and inspect all panels & hardware for damage. If material is found defective, notify Marlite immediately. Failure to do so will be at the sole risk of the installer(s). Store panels in a dry environment similar to final installation conditions. Store panels flat and off concrete floors. Color & texture variations may result from manufacturing techniques. Care must be taken during installation to check panel match before installing. Contact Marlite with questions.

**Caution:** Always wear eye protection and proper protective gear. Use proper safety guards and equipment during fabrication and installation. Note: Metal veneers & hardware can spark or produce sharp metal chips.

**Tools:** Regular carpentry tools, such as table, miter, circular & jig saws, sanding blocks & fine files, appropriate bubble level or laser lever, chalk line, carpenter's square, etc. Use medium-fine tooth carbide blades for cutting. When cutting solid phenolic panels, keep feed speed up to prevent blade overheating and damage.

**Fabrication:** Cut panels "face up" on a table saw or "face down" with a hand-held circular or jig saw. Use a sanding block or fine file to remove burrs or break sharp edges. Refinish exposed panel edges to match factory edges. Trim & hardware are easily cut & mitered using carbide tipped blades in power miter and table saws. Pre-drilling of trim & hardware for attachment is not required if drill-tip screws are used. Where adhesive is needed, Marlite brand adhesives are required. Others may be substituted, with Marlite approval. Follow manufacturer's use & clean-up recommendations for adhesives.

**Clean-up:** Most Marlite panels, trim & hardware are easily cleaned & maintained using a soft cloth and appropriate spray-on cleaner or polish. Dampen cloth with cleaner. Don't over saturate cloth or not spray directly on products. To clean adhesive from most panels and all hardware & trim follow the adhesive manufacturer's recommendation. Always test any cleaner or thinner on a scrap piece of panel before proceeding.

**For questions regarding product or installation issues, contact: Marlite, Surface Systems @ 800-377-1221**

# IMPORTANT! Please read before beginning installation.

## GENERAL NOTE NEMA LD-3 SECTION A.7

### TYPICAL PROBLEMS- CAUSES AND PREVENTION

- A. Stress cracking - Cracking of the laminate at corners and around cutouts (see Figure A-9) may be caused by improper fabrication during installation. Rough edges, inside corners that have not been radiused, and forced fits can cause cracking. Radiusing all edges and inside corners as large as possible 3 mm (1/8 in.) minimum will minimize stress cracking. A radiused corner created by a 6 mm (1/4 in.) diameter router bit is normally used.

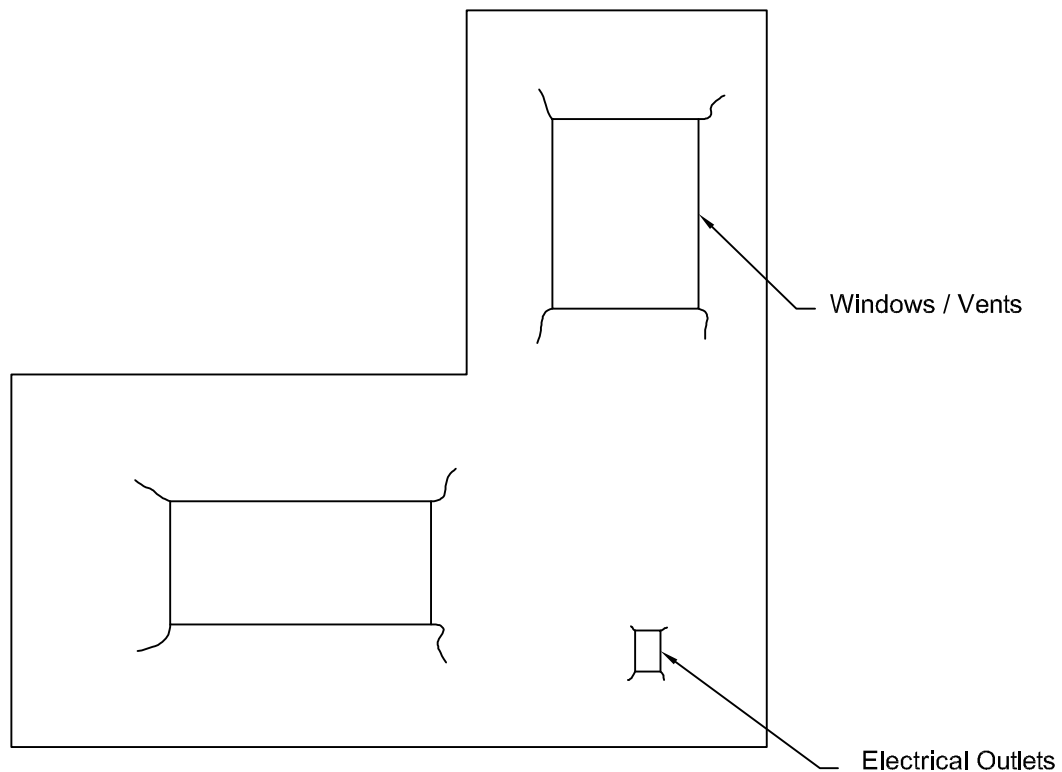
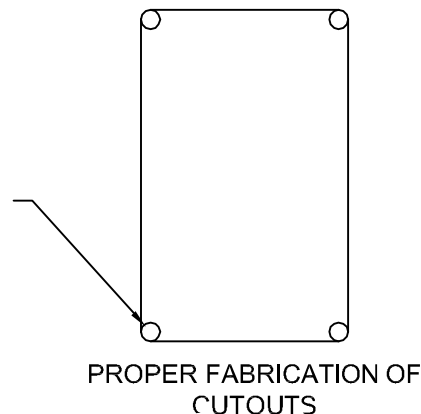

FIGURE A-9  
CRACKING OF LAMINATE

NOTE! To help prevent stress cracking of the laminate, pre-drill all four corners using a 1/4 " bit. Do not square the corners.



PROPER FABRICATION OF  
CUTOUTS

# Exploded view of typical installation

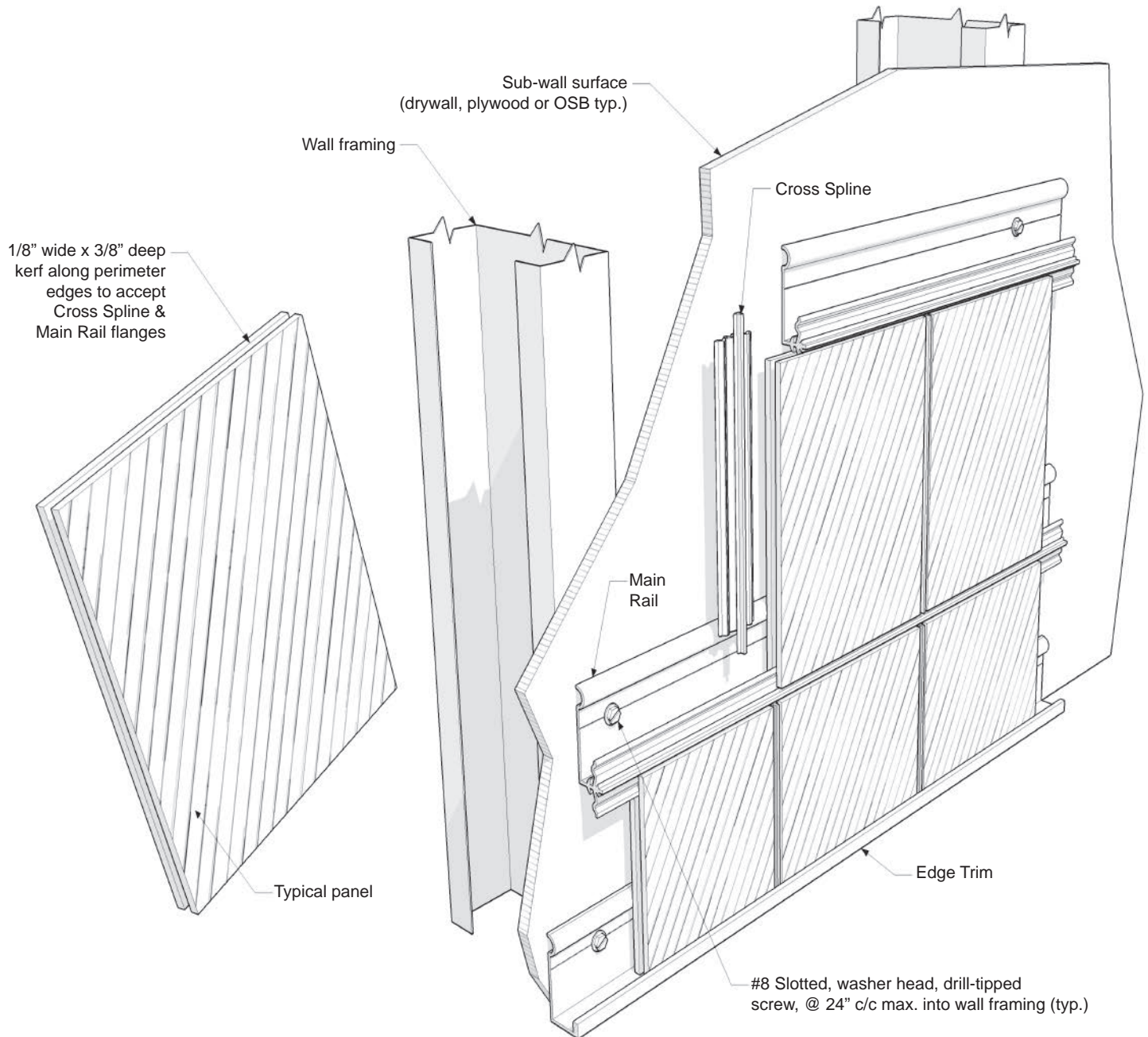

**Product profiles & details may vary by installation.  
Always consult architectural drawings & details  
before installation of any Marlite products.**

**For special detail or installation issues  
Contact:  
Marlite, Surface Systems @ 800-377-1221**

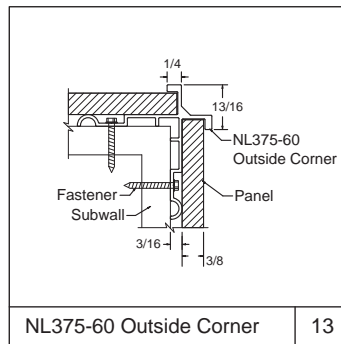
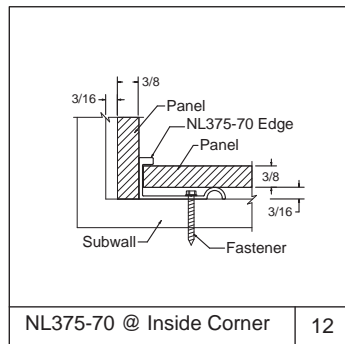
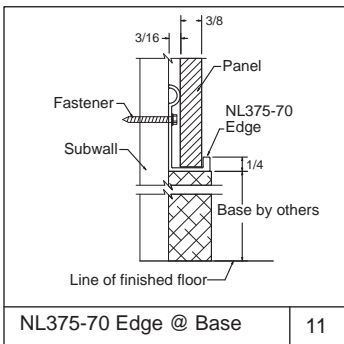
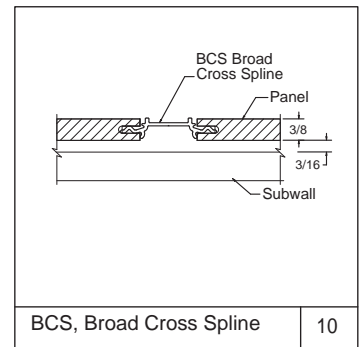
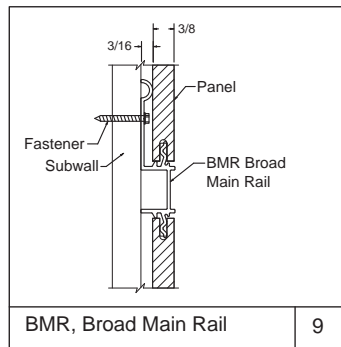
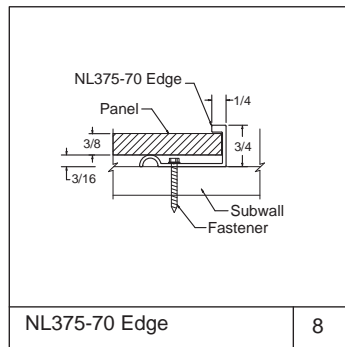
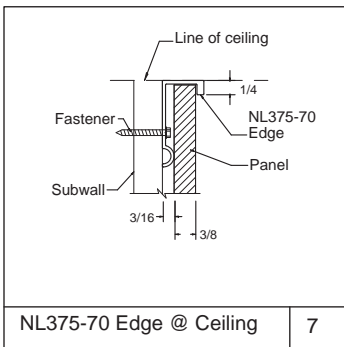
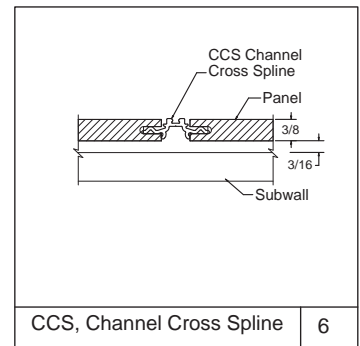
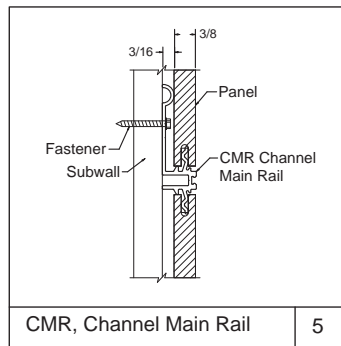
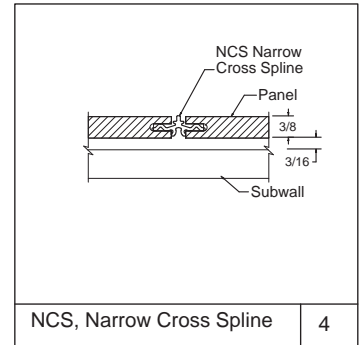
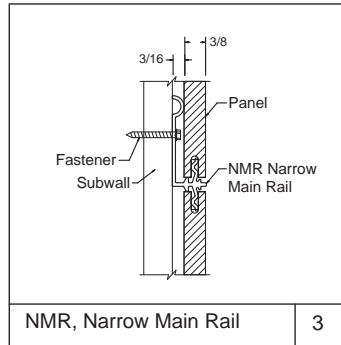
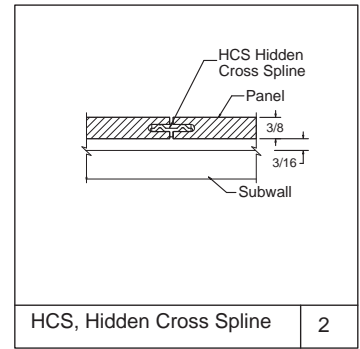
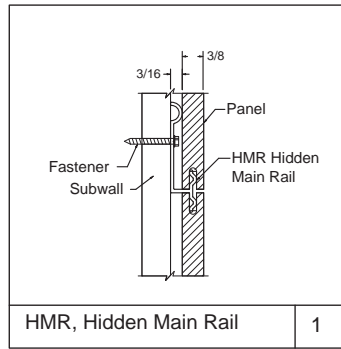
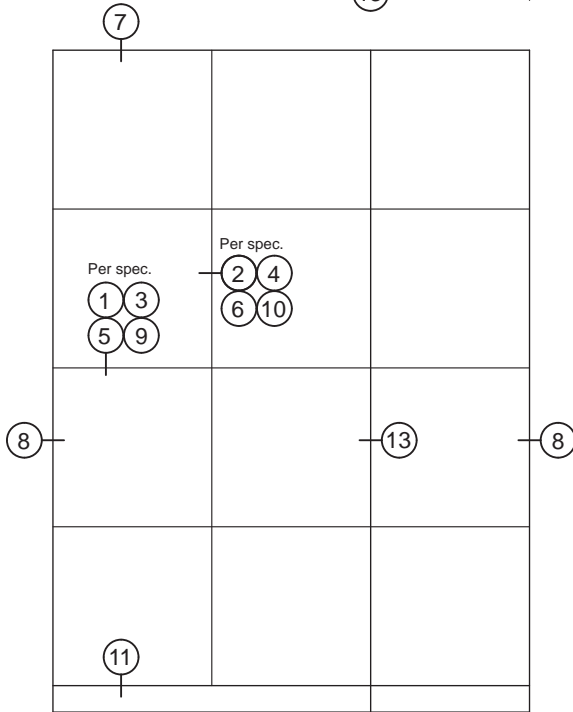
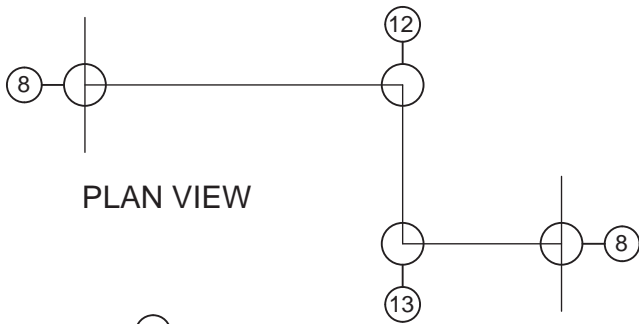

Typical details for hardware & panel installation

# Notching Main Rails to Fit Corner & Edge Trim

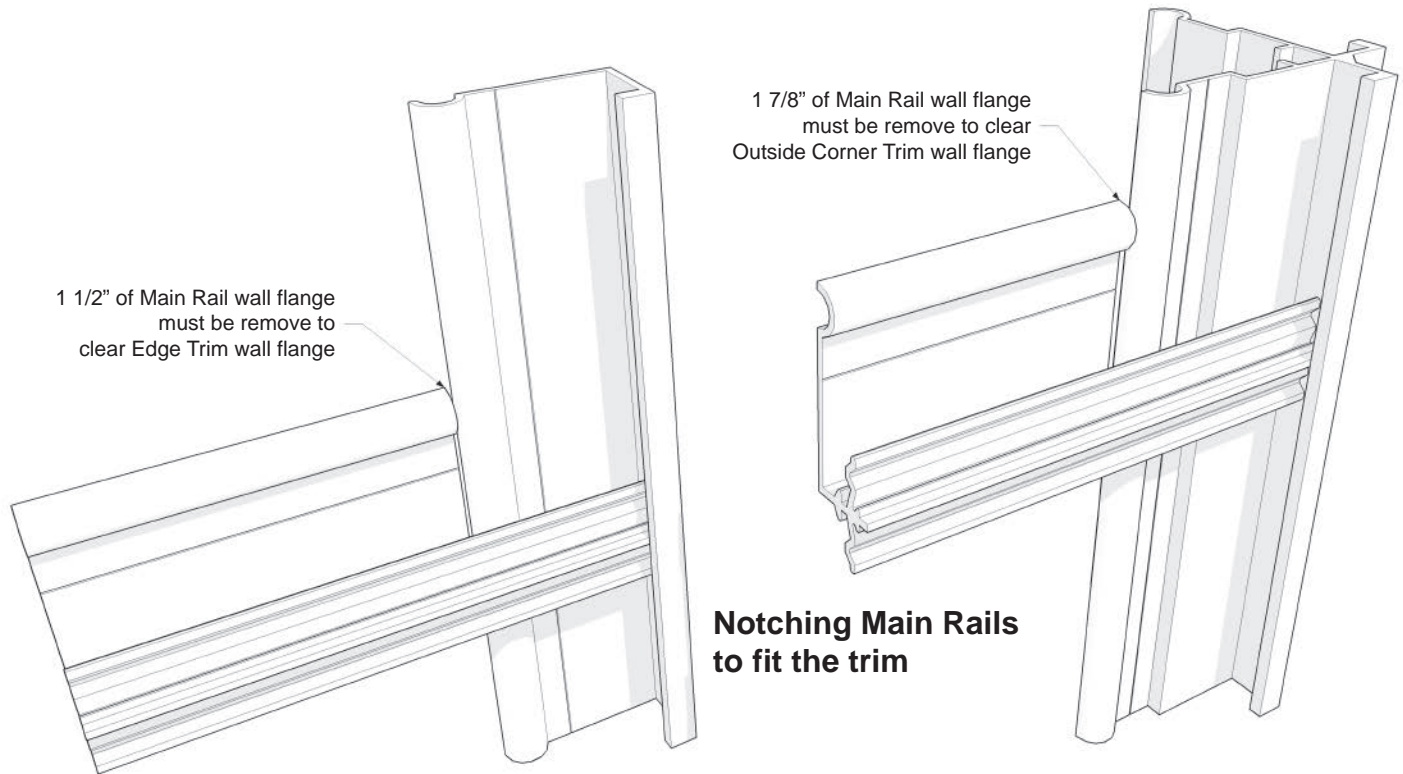

## Notching Main Rails to fit the trim

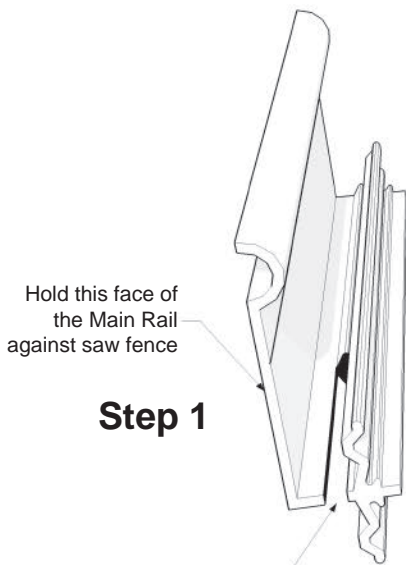
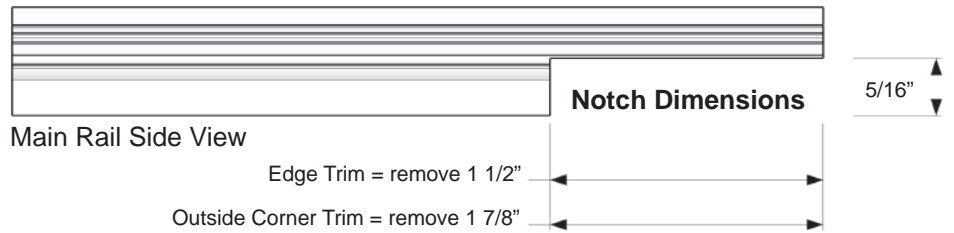

First cut:  
Set table saw fence 3/16" from blade and high as possible

## Cutting notches in the Main Rails

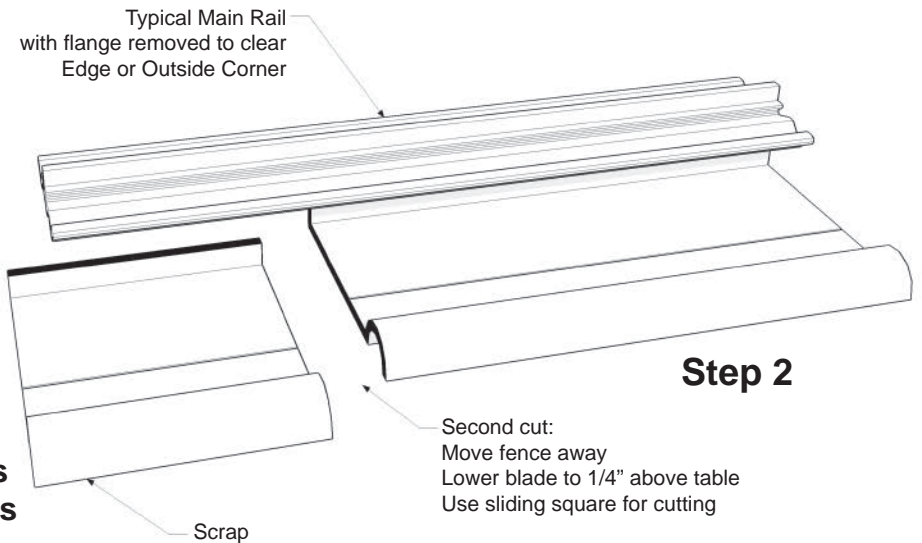

Second cut:  
Move fence away  
Lower blade to 1/4" above table  
Use sliding square for cutting



# Notching Trim for Inside & Outside Corners

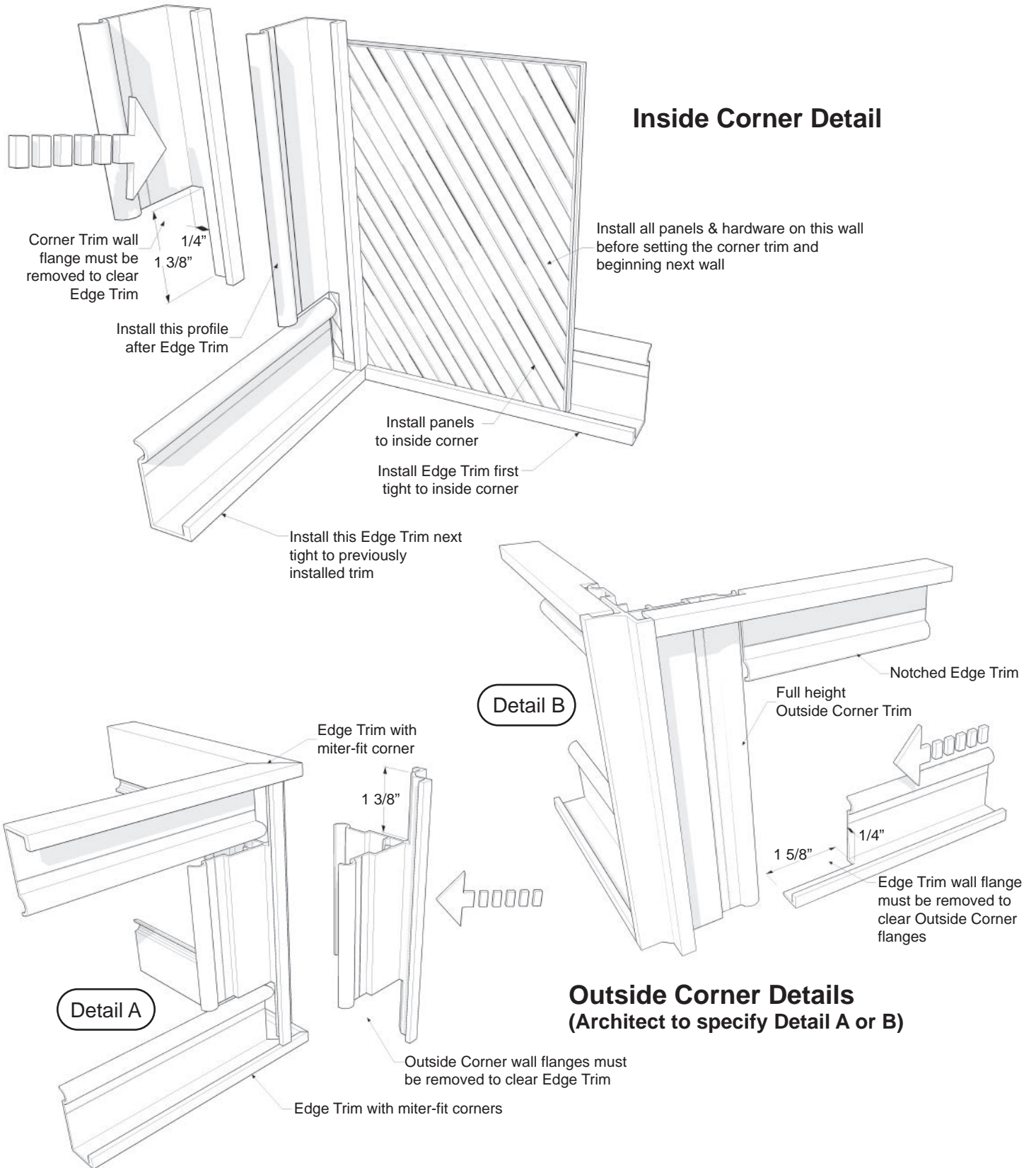

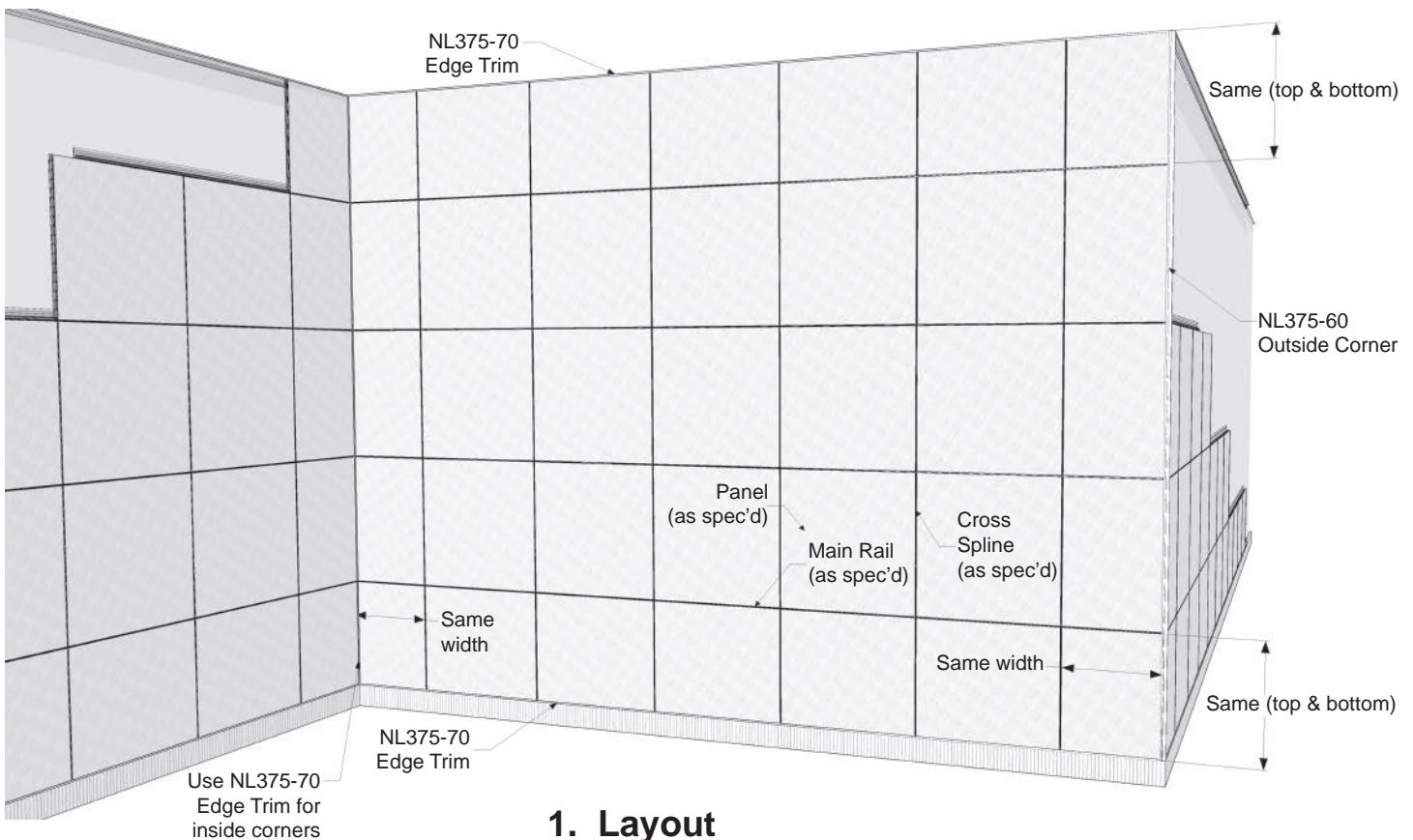

### Follow architectural elevation for panel and hardware layout.

(Otherwise, arrange it so panels along left & right edges are about the same width and panels along top & bottom rows are about the same height.)

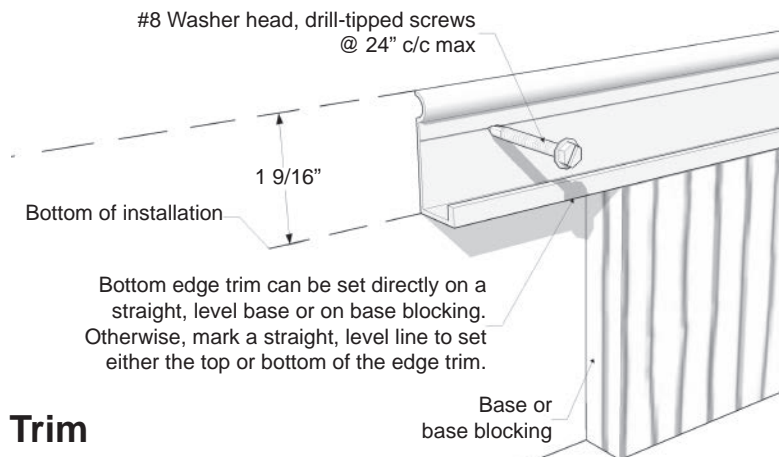

### 3. Install Perimeter Trim

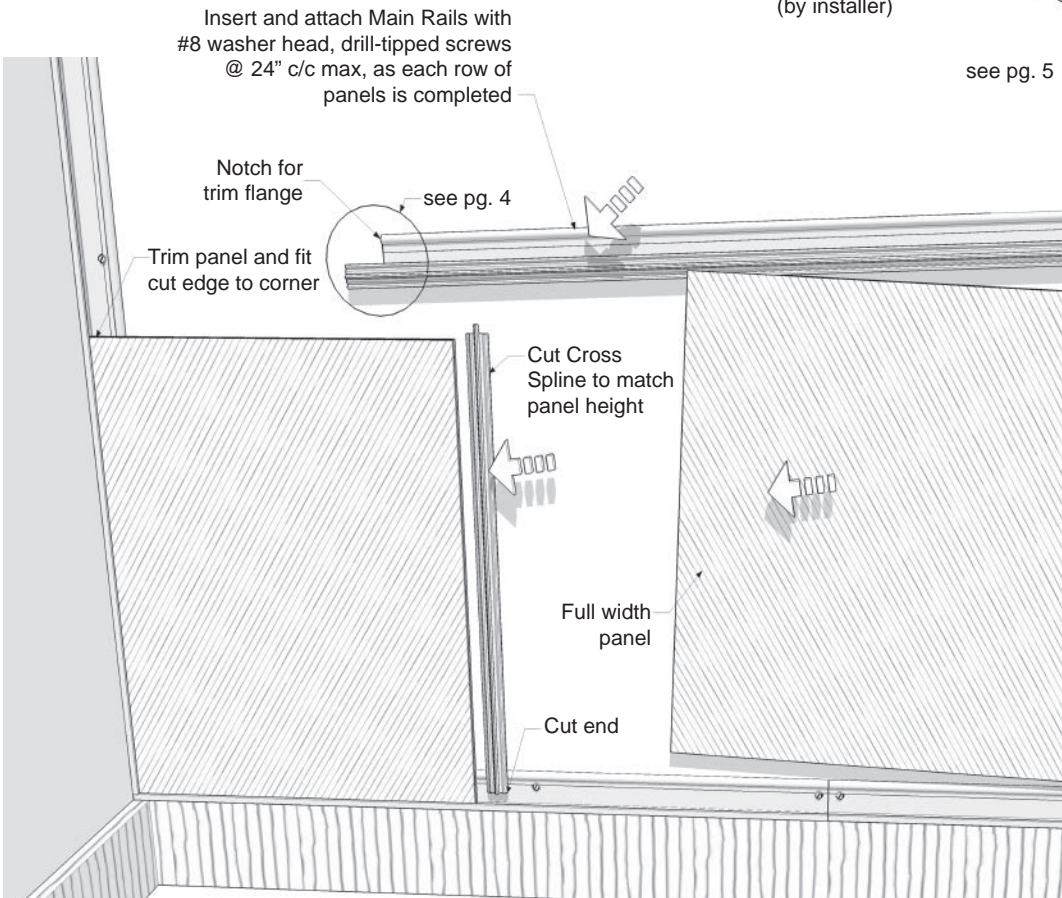
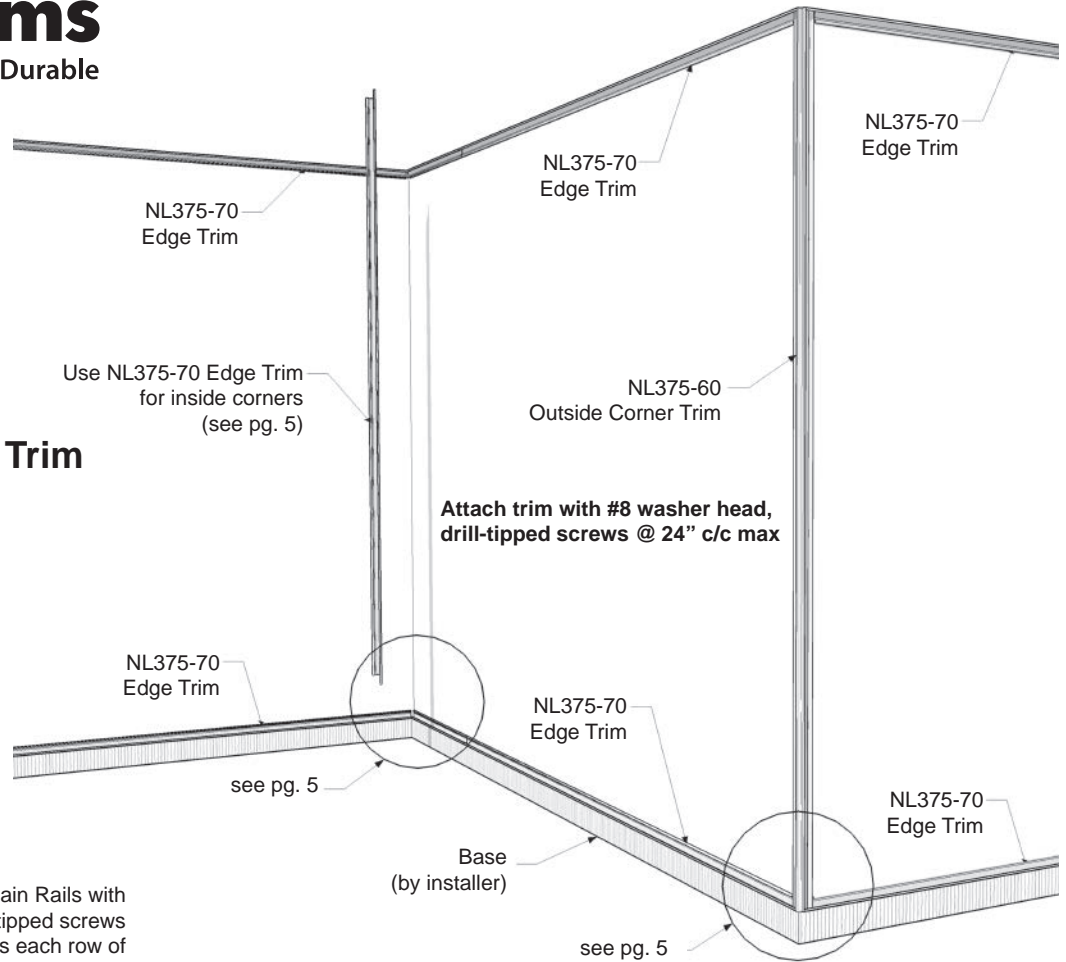

### 4. Install Hardware & Panels, One Row At a Time



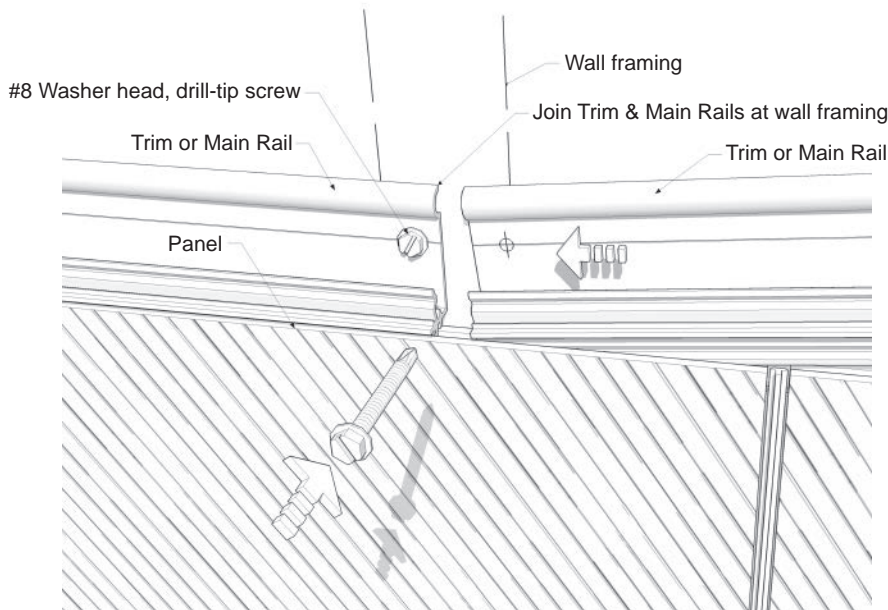

## 5. Close-up of Trim Joint @ Wall Framing

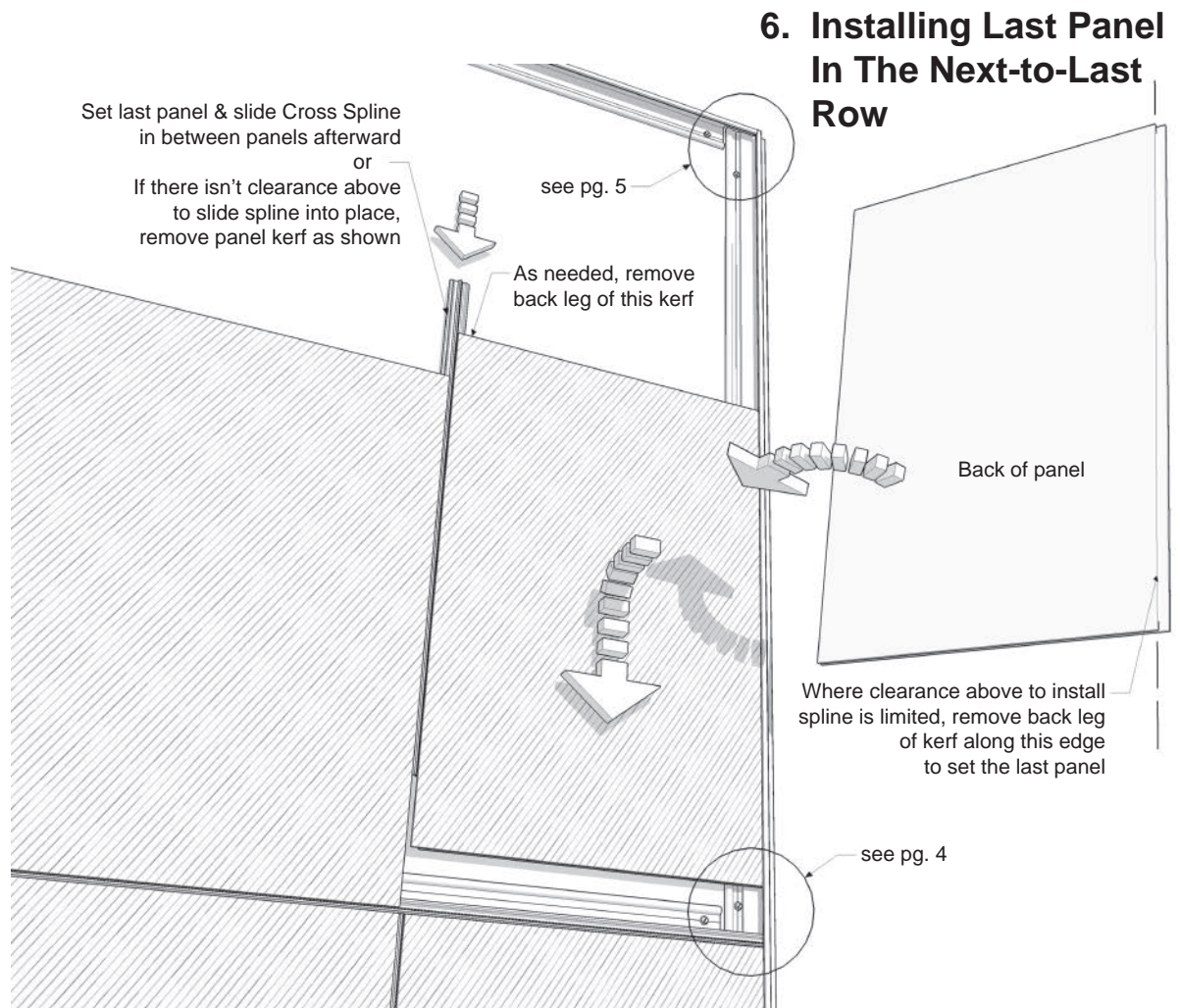

## 6. Installing Last Panel In The Next-to-Last Row

## 7. Installing The Top Row

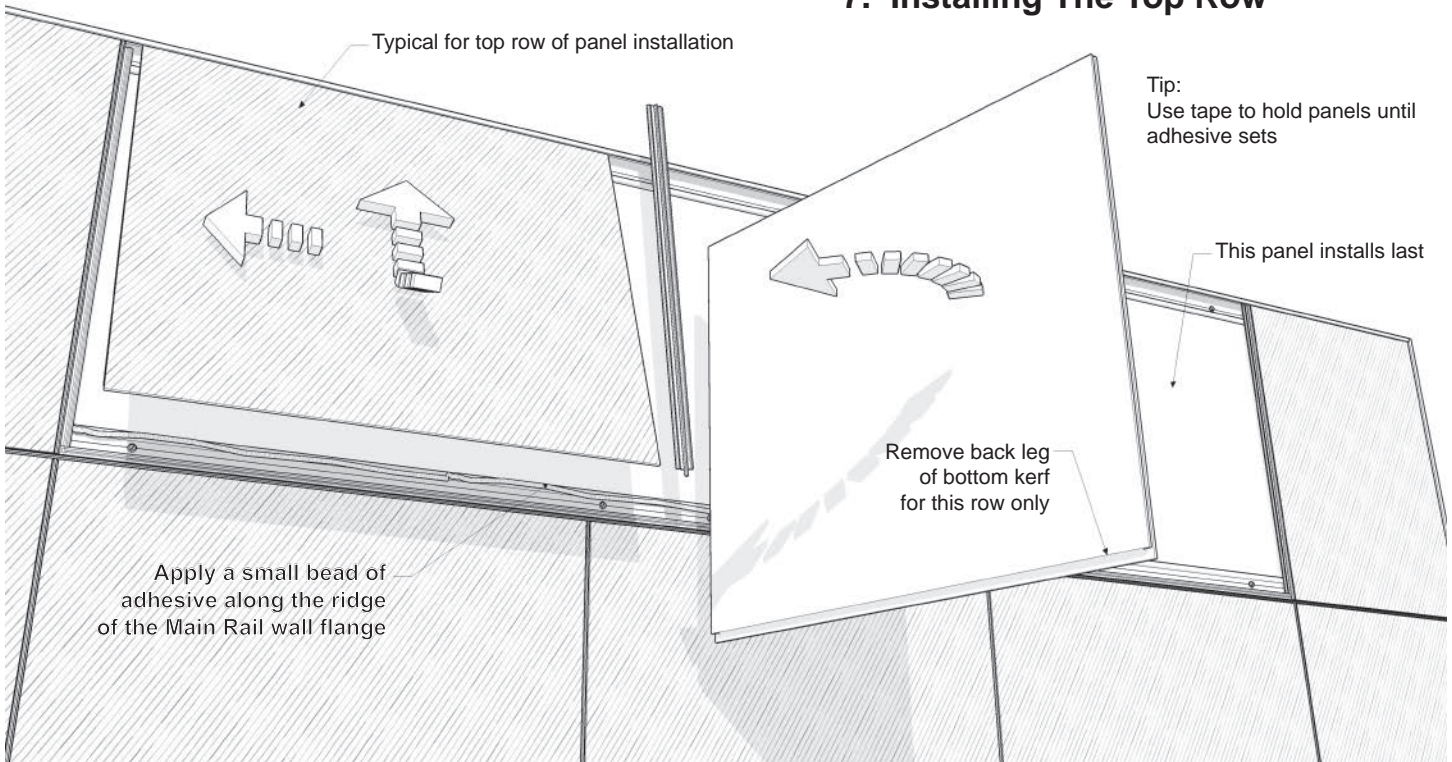

## 8. Installing The Last Panel

