

MX4 Series, 2" Wing Surface Mount Corner Guard w/ Retainer

LENGTH: Feet Inches

QUANTITY:

COLOR:

RCG -2

ALUMINUM RETAINER
.070" [1.8mm] THICK

TEXTURED VINYL
COVER
.080" [2mm] THICK

- Standard Lengths are 4', 8'.
- Custom Lengths are available, all custom cuts have a plus or minus 1/8" tolerance.

Core Colors

- 11921 Black
- 11924 Sawdust
- 11925 Sand
- 11926 Khaki Brown
- 11927 Gray
- 11929 White
- 11930 Taupe
- 11931 Pale Yellow
- 11932 Ivory
- 11933 Brown

Call Factory for availability, lead time, and possible set up charges for Non-Core Colors.

Installation

Surface Mount Corner Guard Systems: Attach end caps to aluminum retainer, mount retainer to the wall, snap on vinyl cover. Field trimming may be required to obtain exact desired height.

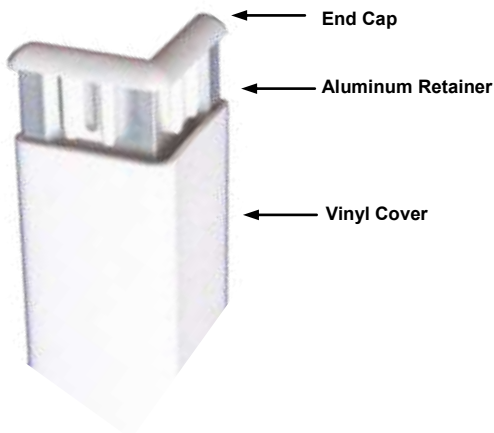
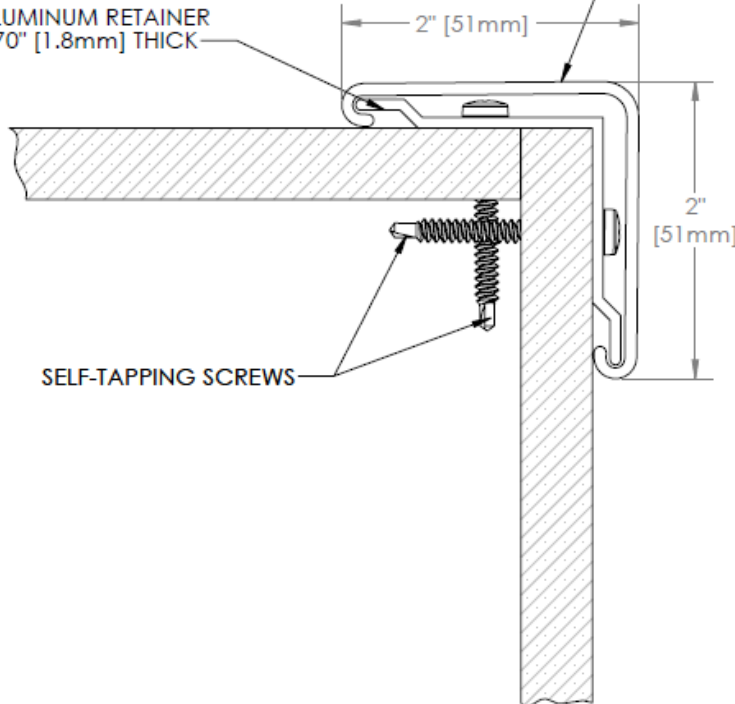

PROPERTIES

- Rigid Vinyl Tensile Yield Strength 6.0, 10³ psi as specified in ASTM D-638, wall thickness .080.
- Contains 50% Recycled Content.
- Chemical and Stain Resistance in accordance with ASTM D-543.
- Does not support fungal and bacterial growth in accordance with ASTM G-21 and ASTM G-22.
- Color Consistency in accordance with SAE J-1545-(DeltaE) with a color difference no greater the 1.0 units using CIE Lab, CIE CMC, CIE Lch, Hunter Lab or similar color space systems.
- Aluminum Retainers are extruded from 6063-T5 alloy, tensile strength of 29,000 psi, a yield strength of 25,000 psi, an elongation (% on 2") of 12 and a Brinell Hardness of 73.



A Division of Nudo® Products, Inc.

1 Marlite Drive
Dover, OH 44622
Ph: (800) 377-1221 Fax: (330) 343-7296
info@marlite.com

PROJECT:

CUSTOMER:

LOCATION:

ARCHITECT:

SALES REP:

REV.

DATE: