

MX6 Series, 4" Wall Guard with Aluminum Retainer

QUANTITY:

COLOR:

END CAPS:

OUTSIDE CORNERS:

- Standard Length is 12'.
- Custom lengths are available, all custom cuts have a plus or minus 1/8" tolerance.

Economy Colors

- 11921 Black
- 11924 Sawdust
- 11925 Sand
- 11926 Khaki Brown
- 11927 Gray
- 11929 White
- 11930 Taupe
- 11931 Pale Yellow
- 11932 Ivory
- 11933 Brown

Call Factory for availability, lead time, and possible set up charges for additional colors.

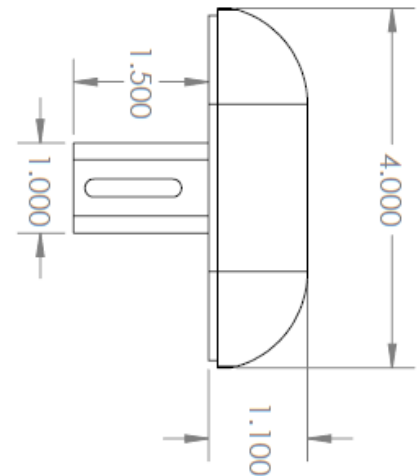
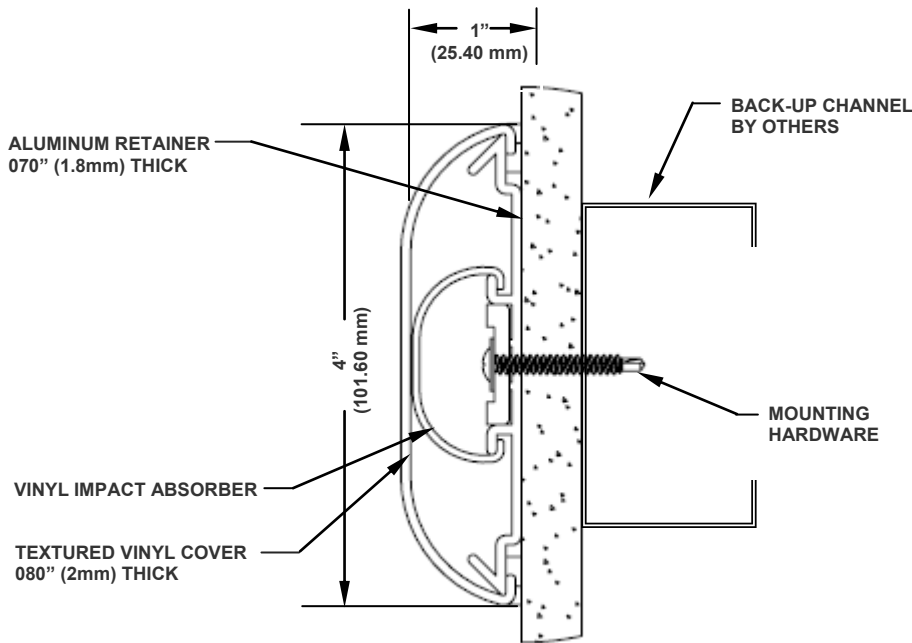

END CAP

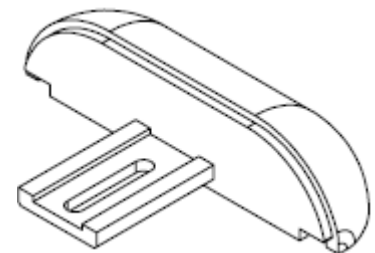

Installation

Wall Guard Systems: Cut aluminum to desired length, attach end caps or corners to the aluminum, attach aluminum to the wall, then cut cover and impact absorber to desired length and snap onto the aluminum. When a splice occurs, splice the aluminum retainer and the vinyl cover at different locations along the run. The use of back-up channels at stud wall conditions is recommended.



A Division of Nudo® Products, Inc.

**1 Marlite Drive
Dover, OH 44622
Ph: (800) 377-1221 Fax: (330) 343-7296
info@marlite.com**

PROJECT:

CUSTOMER:

LOCATION:

ARCHITECT:

SALES REP:

REV.

DATE: