



Surface
Systems



Radius Wall Installation Instructions

Statements expressed in this technical bulletin are the recommendations for the application of Marlite Decorative Wall Products as outlined and illustrated under normal conditions of installation. The recommendations provided in the bulletin represent our best judgment based on our experience with normal applications. Unless prior approval is obtained in writing from Marlite, any deviation from these recommended procedures shall be at the sole risk of the installer.

Important

Read all Installation Instructions prior to any installation. Call Marlite at 330.343.6621 with any questions.

Inspection

Carefully inspect all panels prior to installation. If panel is defective, notify Marlite at once. Failure to do so shall be at the sole risk of the installer. Due to texture and manufacturing techniques, some panels may vary in color, consistency, and pattern. Panels must be stored in a dry environment. Store panels flat and off concrete floors.

Conditioning and Expansion

Radius Wall Panels, like all wood products, are subject to the effects of moisture. Panels must be given 48 hours to condition to room environment. This is accomplished by standing the panels on end around the room. Room temperature should be approximately 70°F. Do not use in kitchens, restrooms, or other high-humidity areas.

Caution

Be sure to use the proper safety guards when cutting panels. Wear safety glasses, face shield, and hand protection. Metal veneer products may produce sparks when cutting. Take proper precautions for dust removal.

Sub Wall Preparation

Structural walls should be finished with building completely closed. Walls must be thoroughly dry before panels are applied. Panels must be applied over a smooth, solid, 3/8" minimum thick backing such as OSB, waferboard, or plywood. For exterior walls, vapor barrier must be used between backer and studs to prevent warping. Protect existing surfaces with drop cloths.

Clean-Up

Radius Wall Panels are easily cleaned with a soft cloth using spray-on furniture cleaner/polish for coated surfaces and spray-on stainless steel cleaner/polish for all metal products. Adhesive can be cleaned from the face of most Radius Wall Panels with Mineral Spirits. Always test thinners on a scrap piece of material. DO NOT SPRAY ANY LIQUIDS ON PANEL FACE OR SATURATE CLOTH WITH LIQUIDS.

IMPORTANT! Please read before beginning installation.

GENERAL NOTE NEMA LD-3 SECTION A.7

TYPICAL PROBLEMS- CAUSES AND PREVENTION

- A. Stress cracking - Cracking of the laminate at corners and around cutouts (see Figure A-9) may be caused by improper fabrication during installation. Rough edges, inside corners that have not been radiused, and forced fits can cause cracking. Radiusing all edges and inside corners as large as possible 3 mm (1/8 in.) minimum will minimize stress cracking. A radiused corner created by a 6 mm (1/4 in.) diameter router bit is normally used.

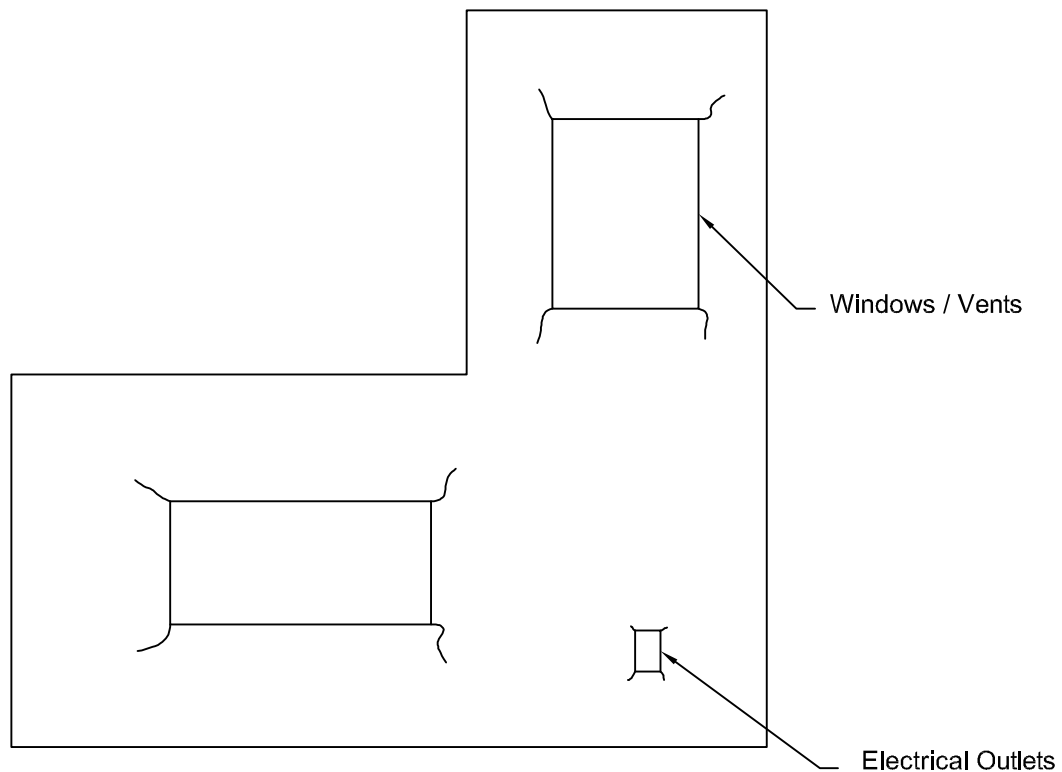
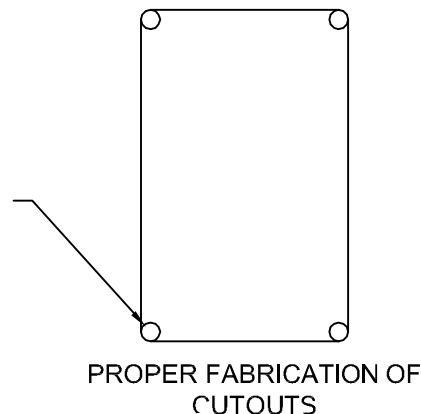
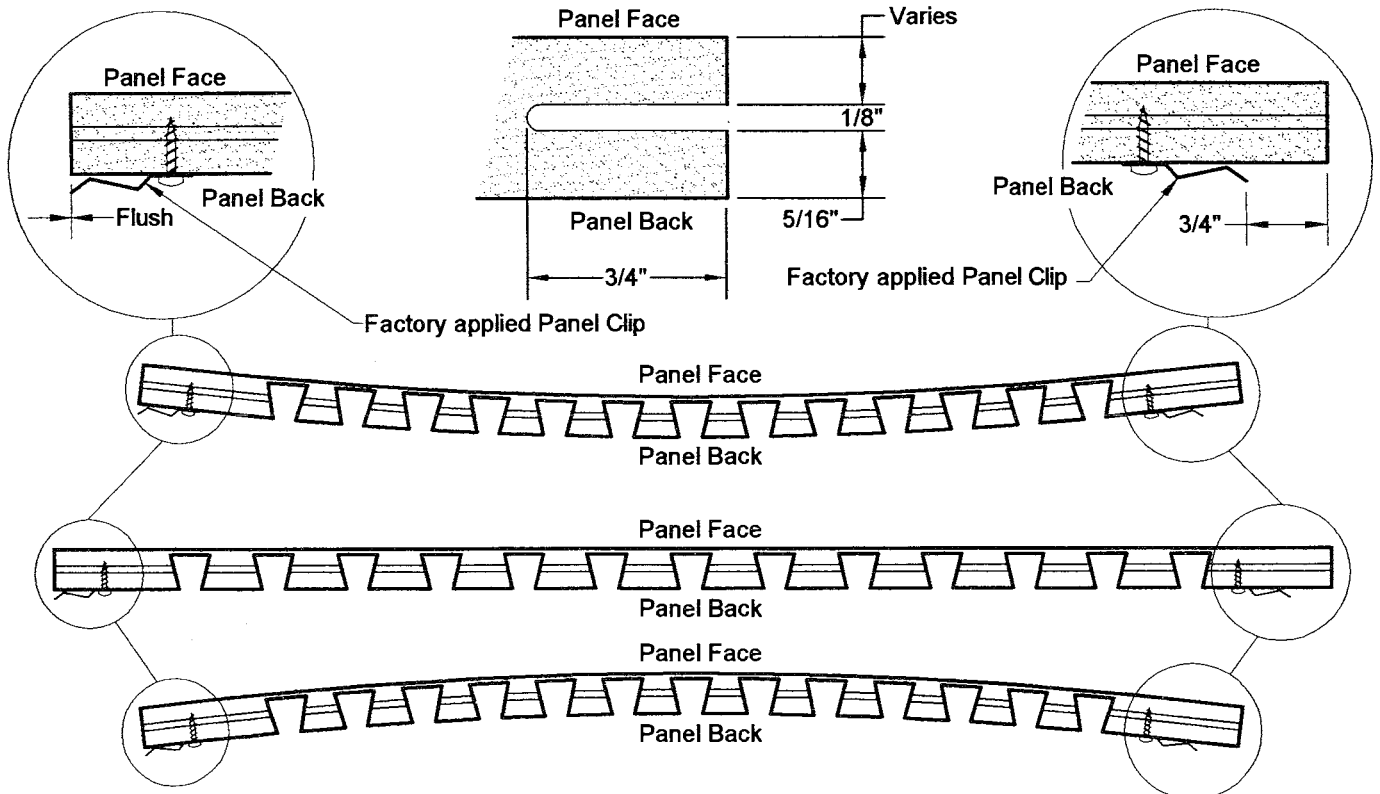
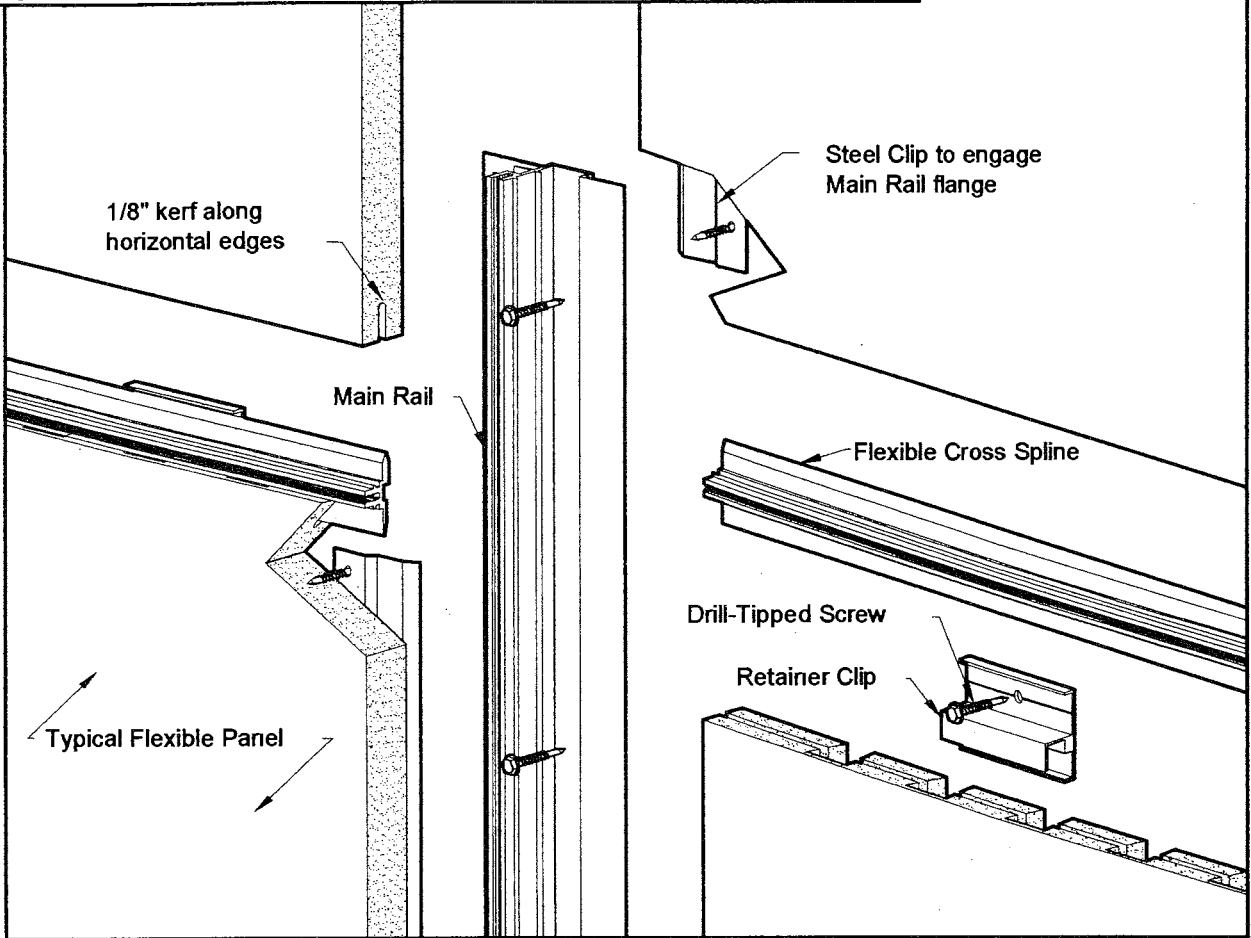

FIGURE A-9
CRACKING OF LAMINATE

NOTE! To help prevent stress cracking of the laminate, pre-drill all four corners using a 1/4 " bit. Do not square the corners.



Exploded View of Radius Wall System



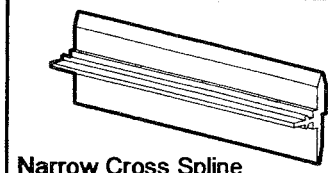

Narrow Cross Spline
NCSRAD

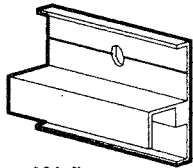

Radius Wall
Retainer Clip

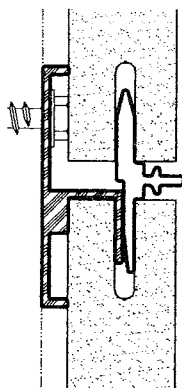

Detail: A-1

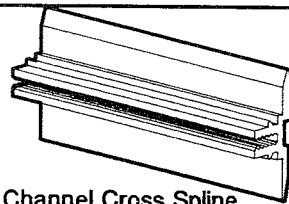

Channel Cross Spline
CCSRAD

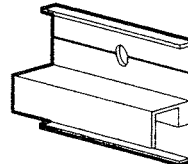

Radius Wall
Retainer Clip

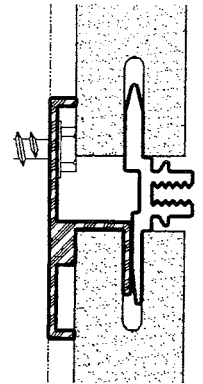

Detail: A-2

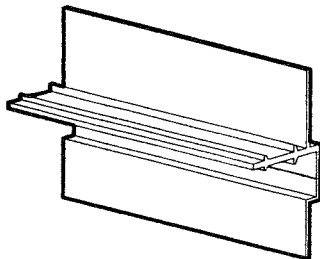

Narrow Main Rail
NML-8

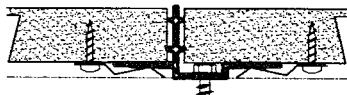

Detail: A-3

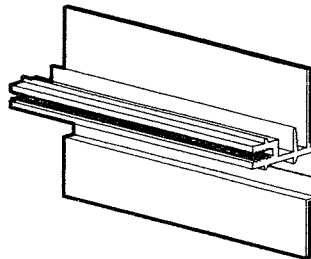

Channel Main Rail
CML-8

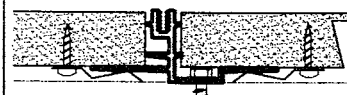

Detail: A-4

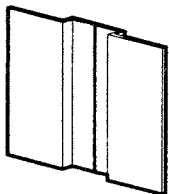

Panel Spacer
IML-PS

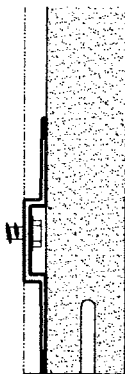

Detail: A-5

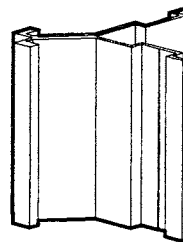

Narrow Line Outside Corner
NL-760

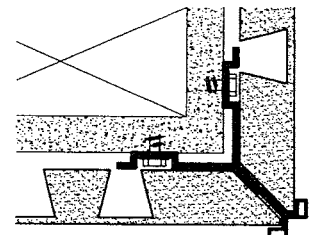

Detail: A-6

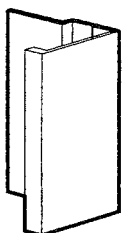

Narrow Line Edge
NL-770

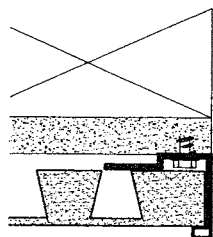

Detail: A-7

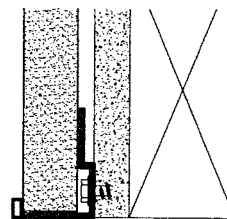

Detail: A-8

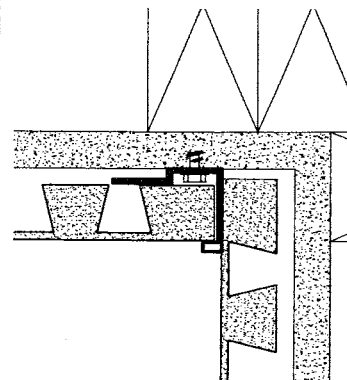

Detail: A-9

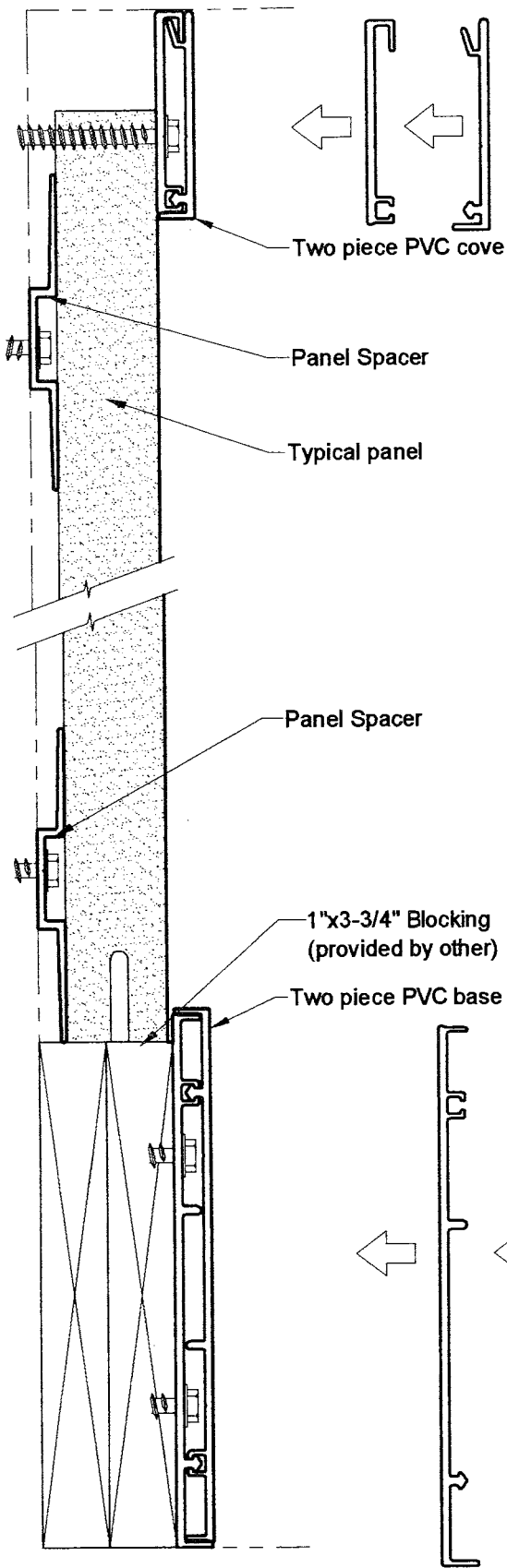

Detail: A-10

Flexible Cove & Base Details

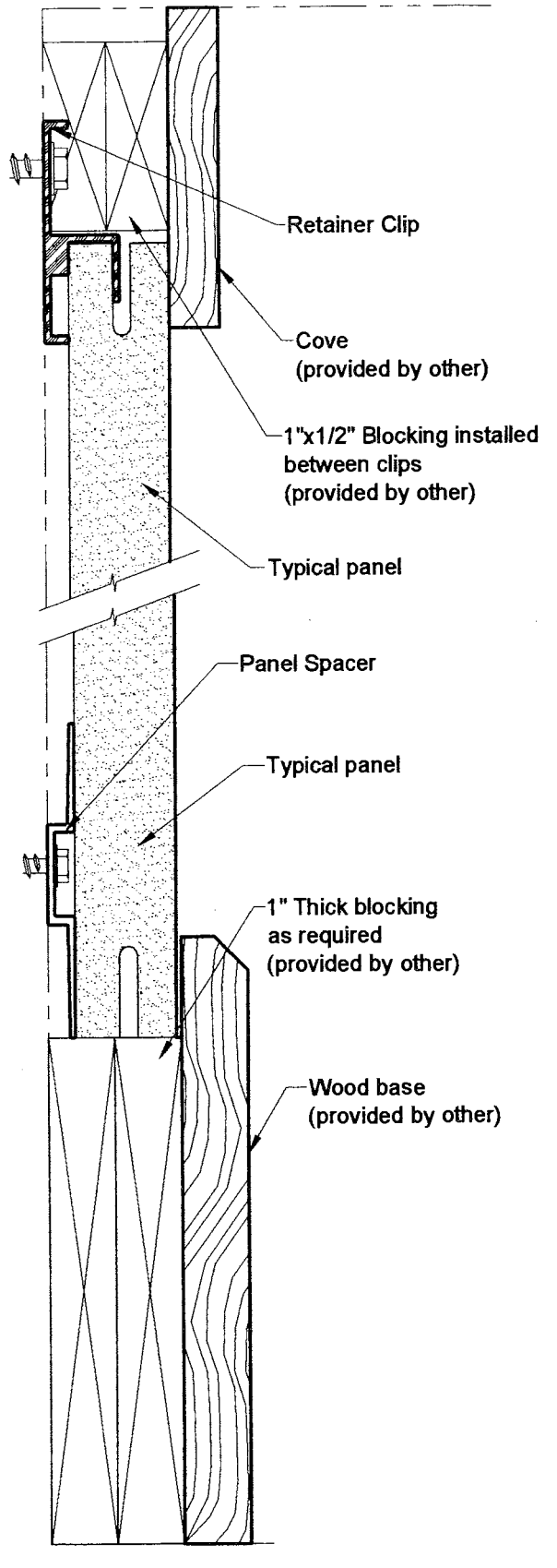

Detail: A-11

Wood Cove & Base Details

Detail: A-12

Narrow Main Rail (NML-8) to Narrow Line Edge (NL-770)

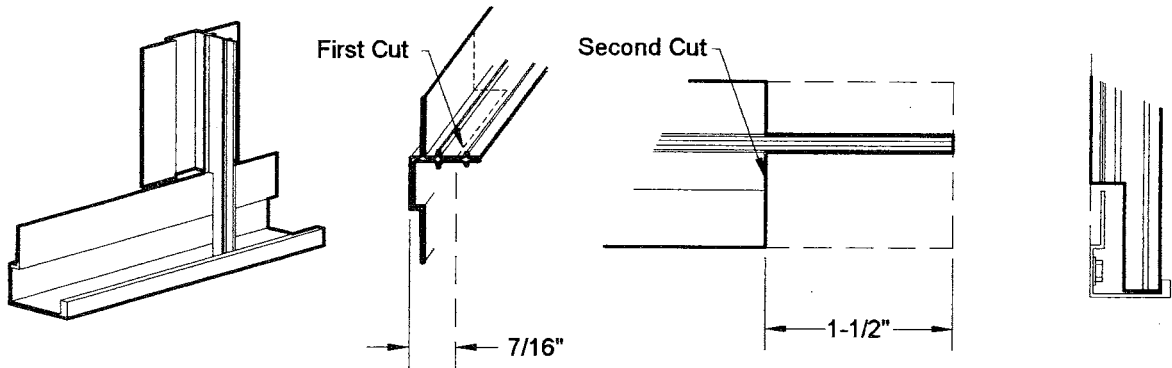

Note: Dimensions will be the same when using Channel Main Rail (CML-8)

Detail: A-13

Narrow Line Edge (NL-770) to Narrow Line Edge (NL-770)

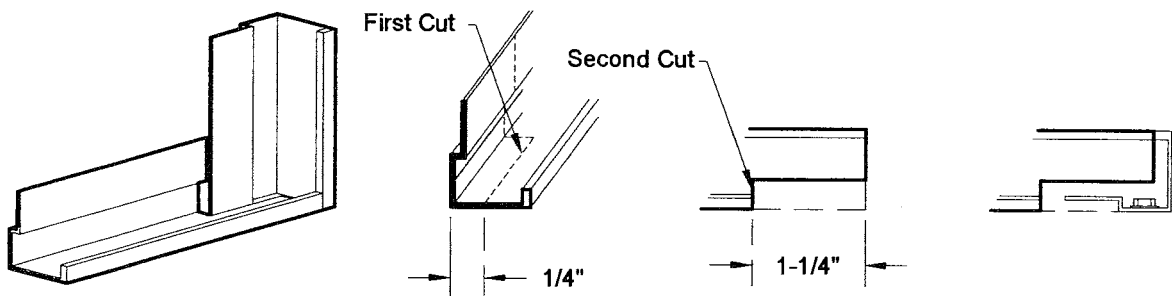

Detail: A-14

Narrow Line Edge (NL-770) to Narrow Line Outside Corner (NL-760)

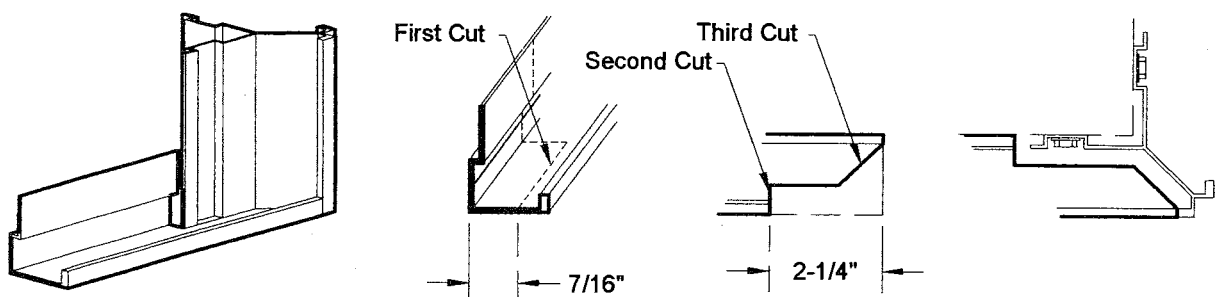

Detail: A-15

Narrow Main Rail (NML-8) to Narrow Main Rail (NML-8)

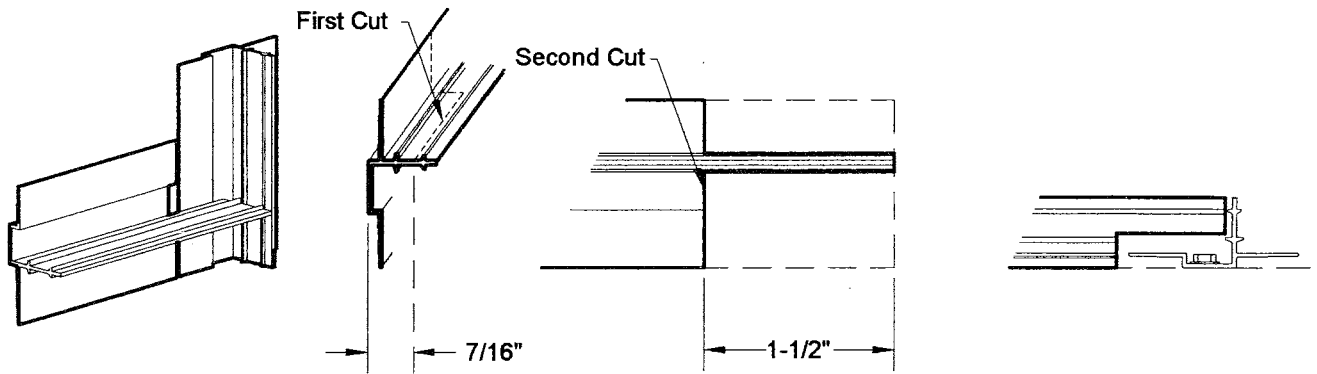

Note: Dimensions will be the same when using Channel Main Rail (CML-8)

Detail: A-16

Narrow Main Rail (NML-8) to Narrow Line Edge (NL-770)

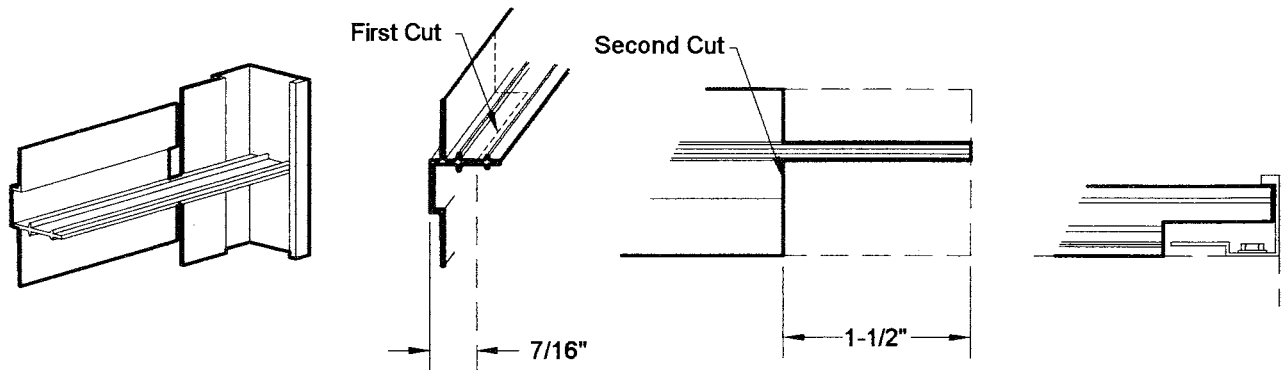

Note: Dimensions will be the same when using Channel Main Rail (CML-8)

Detail: A-17

Narrow Main Rail (NML-8) to Narrow Line Outside Corner (NL-760)

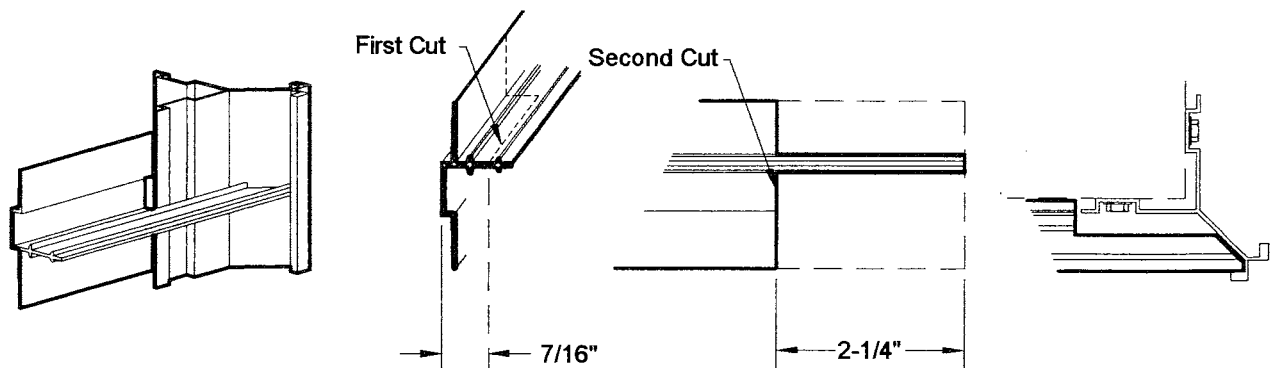

Note: Dimensions will be the same when using Channel Main Rail (CML-8)

Narrow (NCSRAD)
or Channel (CCSRAD)
Cross Spline (Horizontal)

Narrow Line
Edge Trim
(NL-770)

Panel

Narrow (NML-8)
or Channel (CML-8)
Main Rail (Vertical)

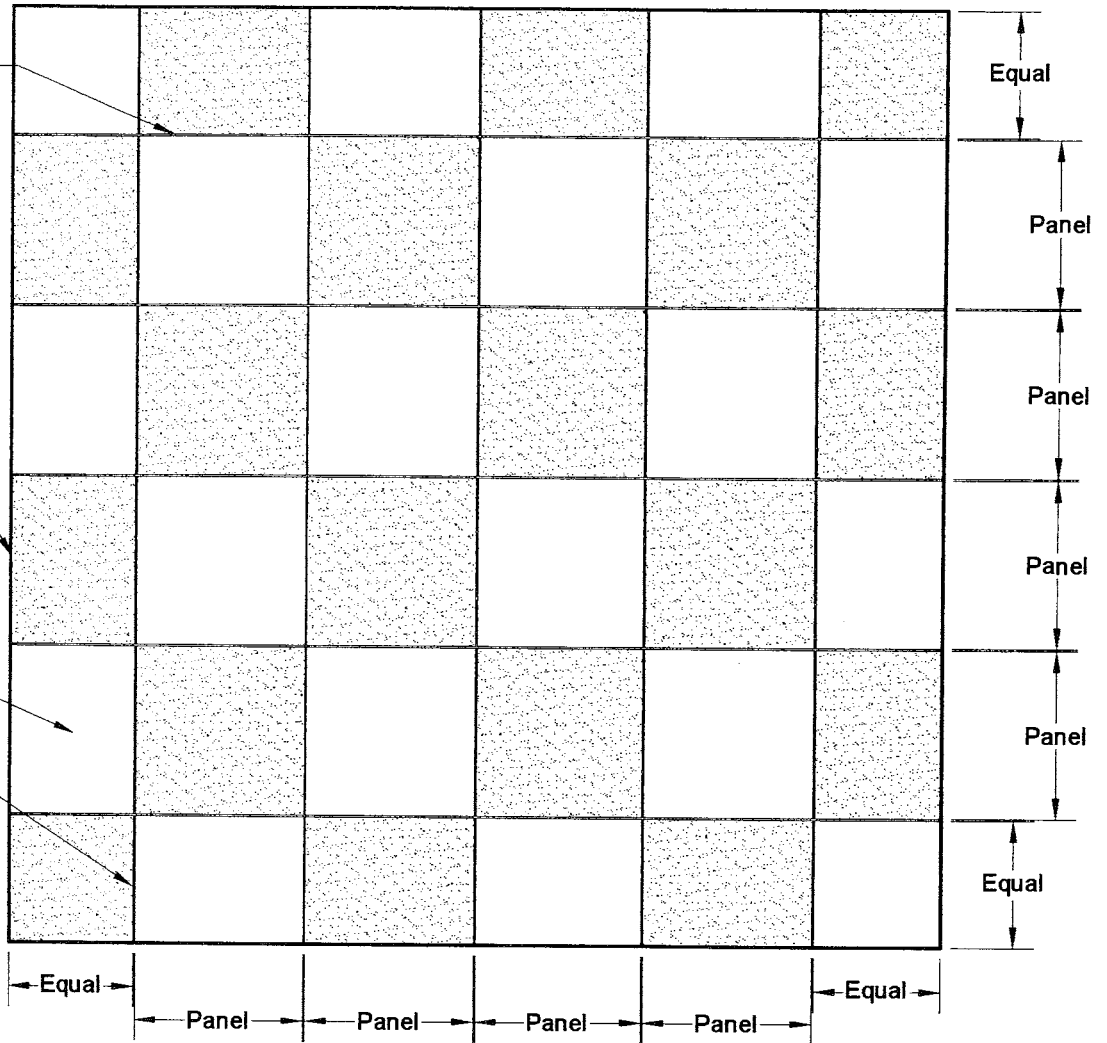

See architectural elevation to determine layout and location of panels. To pre-plan a balanced layout, top & bottom panels should be equal in height and end panels should be equal in width (see above illustration). Before installation begins, it may be necessary to arrange panels on the floor to determine the best combination of color and pattern.

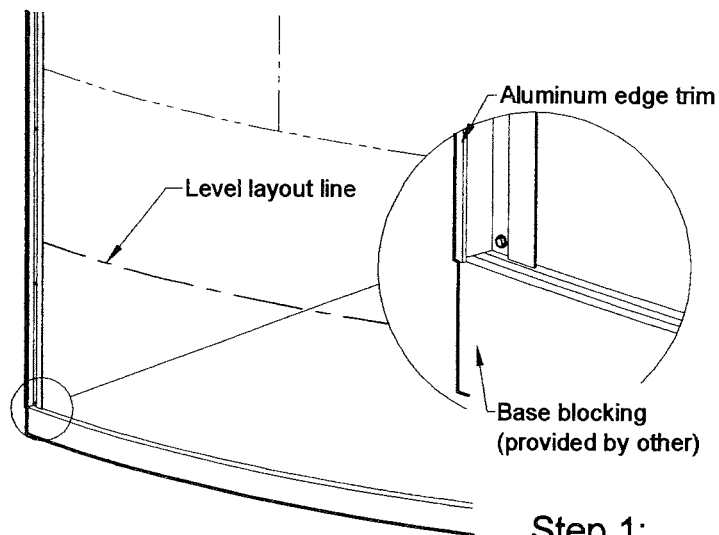

Always use Radius Wall application hardware and perimeter trim designed for the job. They are easily cut with a hack saw or power miter box. Be sure to finish all cut edges.

The subwall must have a minimum of 3/8" plywood face for application of panel system. The plywood must be applied following any construction required by fire codes. Local code may require the use of fire-retardant plywood.

Step 1:

Install layers of Plywood, OSB or Waferboard to create a 1" thick wood base blocking to hold base away from wall and allow the base to be flush against the face of the Radius Wall Panel.

Step 2:

Establish height at first horizontal reveal from architectural drawings and trim panel as required. Next, snap a level line that will serve as the horizontal reference when installing the wall system.

Tools

Tools Required: Regular carpentry tools such as a level, sanding block, drill, table saw or circular saw with a fine-toothed carbide blade, chalk line, tape measure, miter box, tin snips and a square.

Note:

Remember to allow for the width of the spline reveal when trimming the bottom of the panel.

Note:

When the Radius Wall transitions into a flat wall, it is easiest to begin the installation at the Radius Wall and finish the installation at the flat wall.

Step 3:

Install edge and outside corners as required. Inside corners will be installed during panel assembly.

Note:

The panel clips are attached to the back of the panels. The clips are mounted flush on one vertical edge and 3/4" from the other vertical edge. The 3/4" recess goes on the Main Rail side during installation. The horizontal edges of the panel have kerfs cut into them.

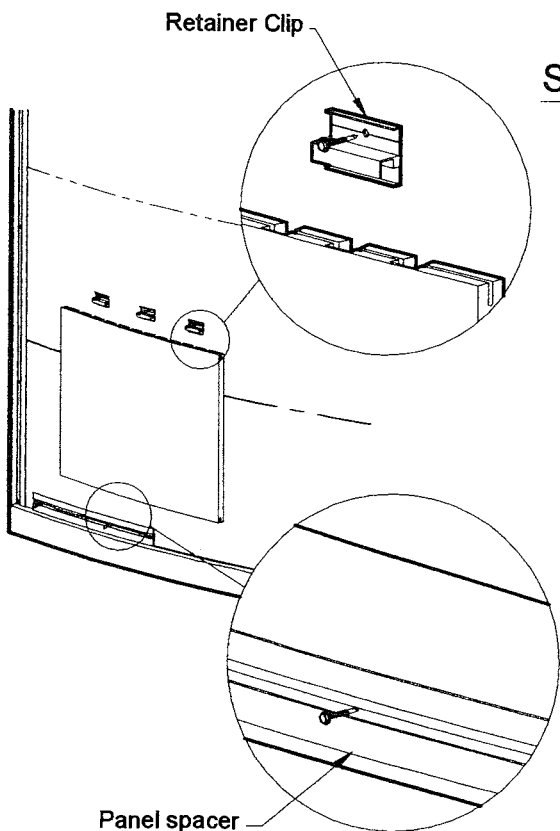

Insert retainer clips into panel top edge (space retainers 8" on center maximum). Fasten retainer to wall with the drill-tipped screws provided.

Step 4:

Install cross spline into top edge kerf. Be sure that the thinner edge is inserted with the clips. Measure and cut the cross spline to match the width of the first panel.

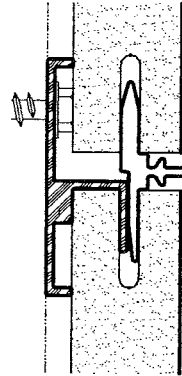
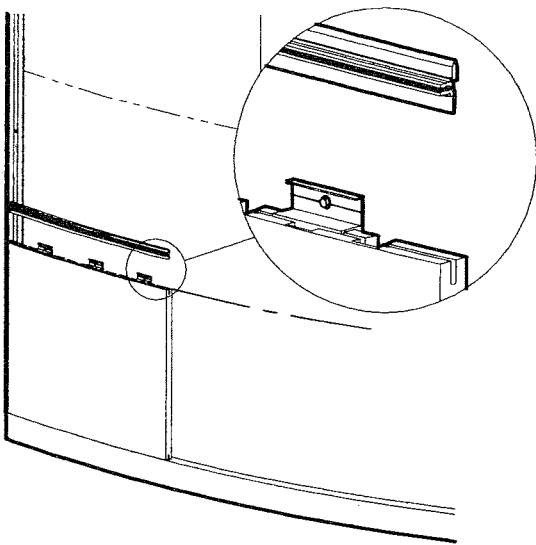

Detail: A-1
Narrow Profile

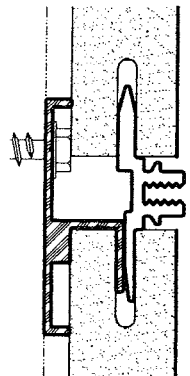

Detail: A-2
Channel Profile

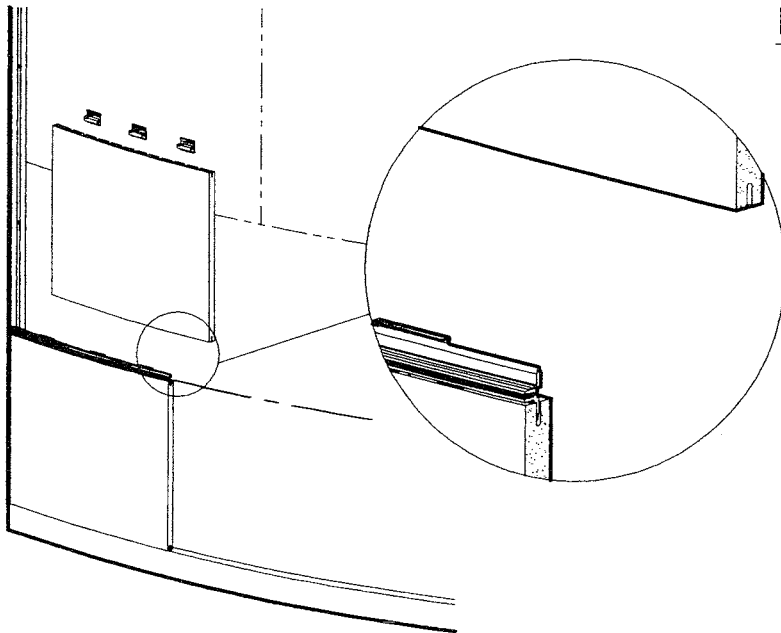

Step 5:

Repeat previous steps with full height panels to the top of the wall. If the topmost panel requires trimming, the edge kerf must be re-cut using a table saw or router.

Note:

Use the removed edge for setup. The topmost panel should be kept 1-3/4" from the ceiling to allow access to retainer clip. This space will be covered with trim.

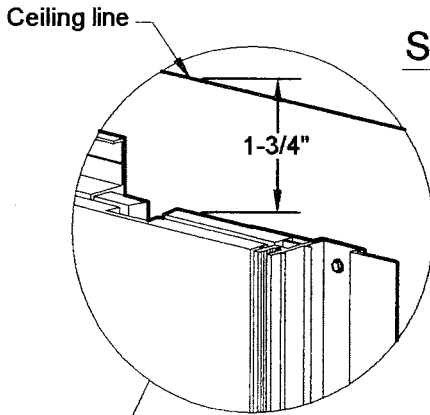

Step 6:

The vertical Main Rails are inserted into the clip along the vertical edges as shown. Attach the Main Rail to the wall with the drill-tipped screws provided at 32" on center maximum. Be sure that the panel clips properly engage the hardware flange.

Note:

Always cut panels "face up" with a table saw, or "face down" with a portable power saw to assure a clean-cut edge. The use of a sanding block will provide a clean edge.

Note:

ALWAYS REFINISH AND SEAL TRIMMED EDGES.

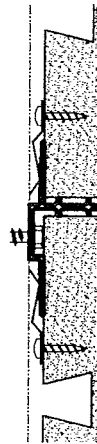
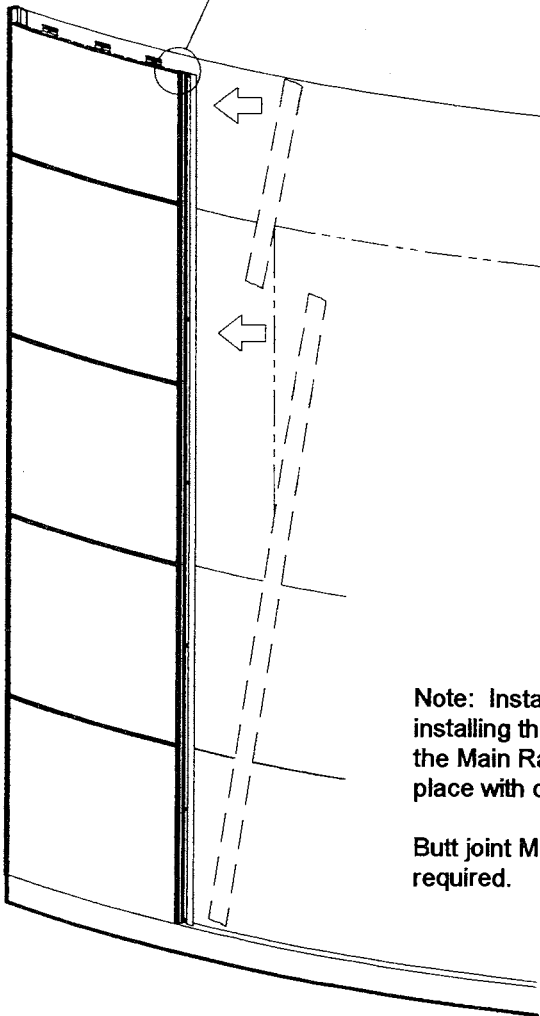

Detail: A-3
Narrow Profile

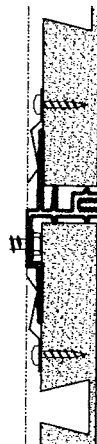

Detail: A-4
Channel Profile

Note: Install Main Rail at an angle by first installing that bottom corner and then working the Main Rail into position. Mechanically fasten into place with drill-tipped screws provided.

Butt joint Main Rails together when additional lengths are required.

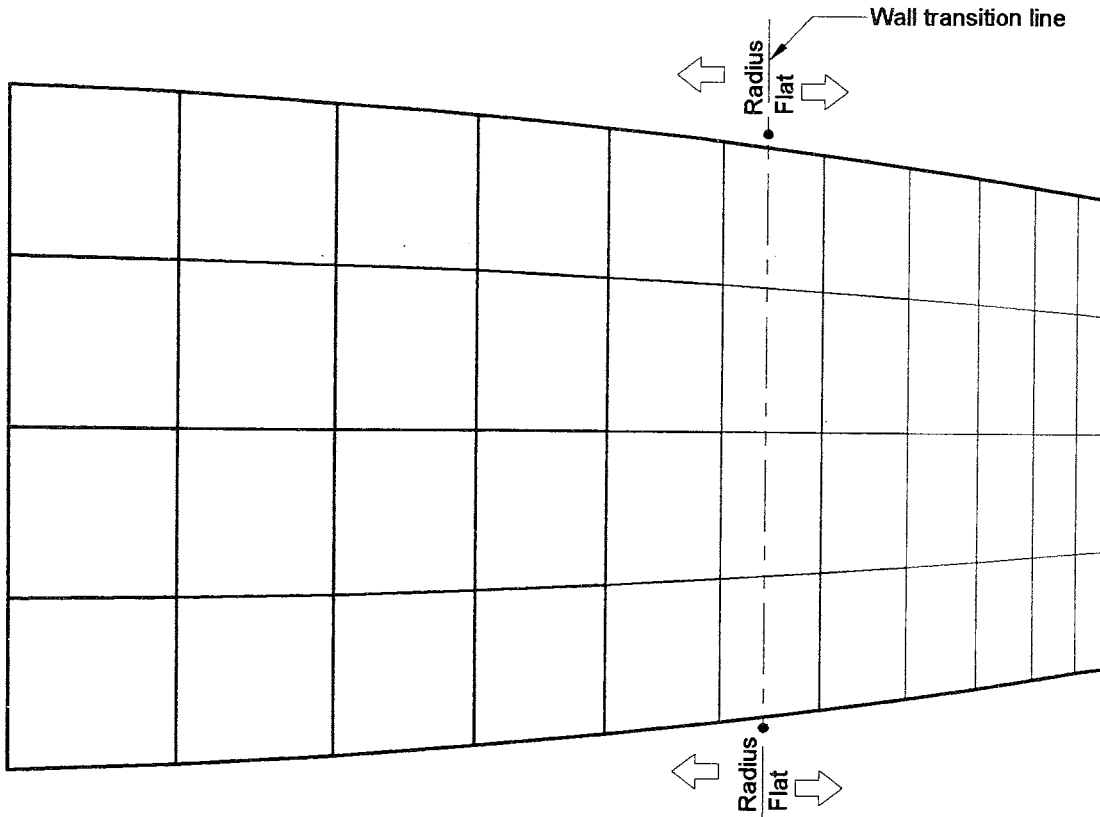

When transitioning from a radius wall to a straight wall, Radius Wall Panels must be installed beyond wall transition line. Once installation is past the wall transition line, depending on the length of the flat wall, the installation method may change from Radius Wall System Installation to the MAP System Installation. Contact Marlite at: 330.343.6621 or toll free at 800.377.1221 if MAP System Installation Instructions are not provided.

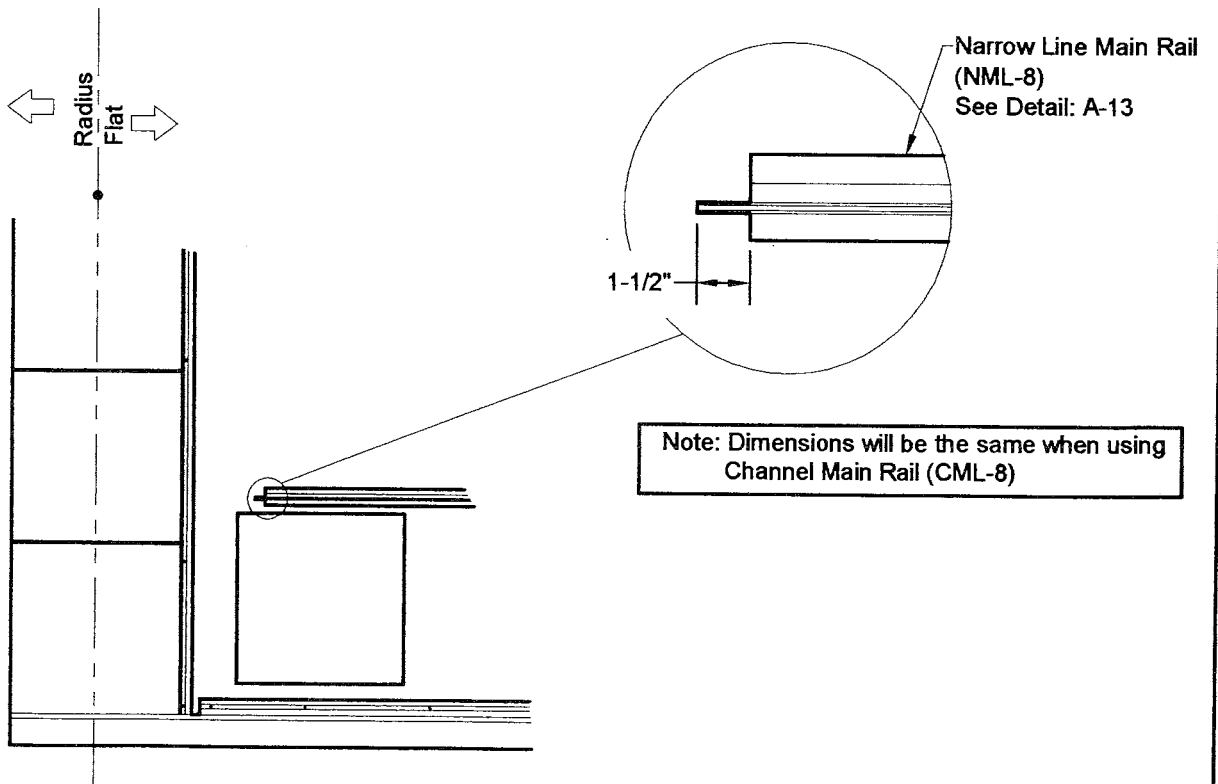

Note: Dimensions will be the same when using Channel Main Rail (CML-8)

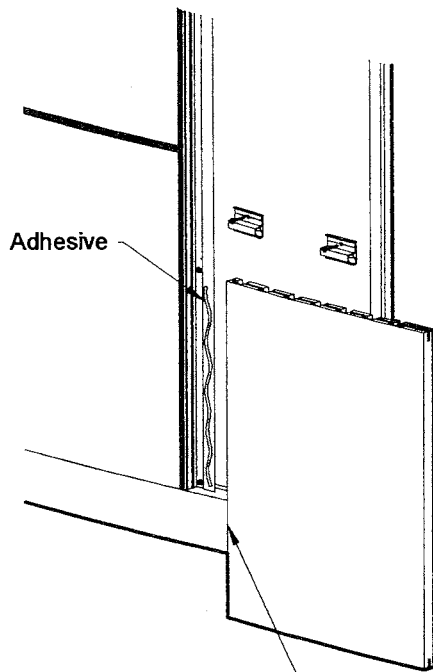

Note: When installation ends into a Narrow Line Edge (NL-770) or a Narrow Line Outside Corner (NL-760) and the panel is 15" wide or narrower, remove the clip from the Main Rail side. Apply a bead of adhesive to the Main Rail flange. Slide the Panel Clip onto the trim flange and then push the Main Rail side into place. Be sure to check for proper adhesive transfer from the Main Rail to the back of the panel.

Note: Adhesive Required: Marlite Brand C-702 Adhesive is the recommended adhesive. This adhesive is a solvent-based adhesive and may be restricted by some local codes. Any adhesive substitutions must meet manufacture's approval prior to use. Clean tools with naphtha or mineral spirits. Read cautions on adhesive package prior to use.

Less than 15" wide, trim this edge.

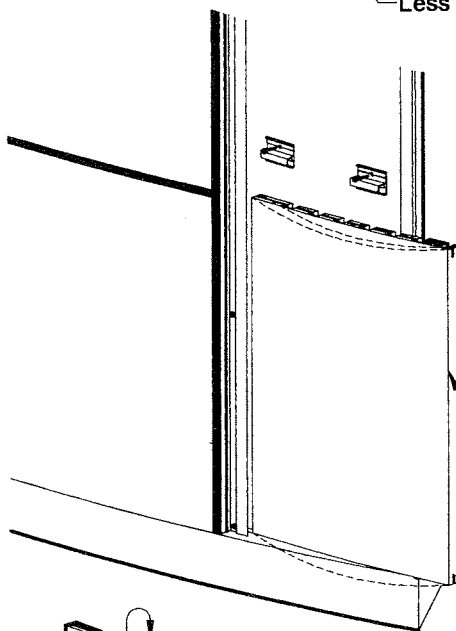

Note: When installation terminates into a Narrow Line Edge (NL-770) or a Narrow Line Outside Corner (NL-760) and the panel is wider than 15", slide the panel clip onto the Main Rail flange first, and then bend the panel to engage the edge of the panel into the trim.

Over 15" wide, trim this edge.

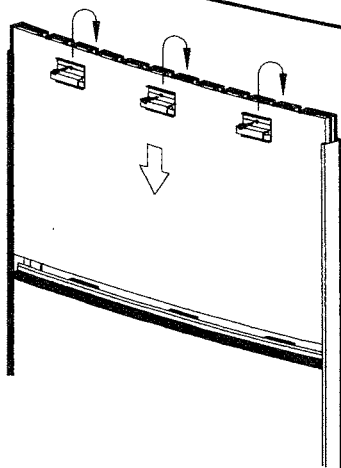

Note: To install the last, topmost panel, install high enough to clear the cross-spline, and then slide the panels down into place. Mechanically fasten to the wall with the panel retainer clips and drill-tipped screws provided.