

MasterFlow[®] 648

High-strength, high-flow epoxy grout

FORMERLY MASTERFLOW[®] 648 CP PLUS

PACKAGING AND YIELD

- 54.4 lb unit (0.4 ft³ [0.01 m³])
 - 5.5 lb (2.5 kg) pail Part A (Resin)
 - 1.65 lb (0.75 kg) bottle Part B (Hardener)
 - 47 lb (21.3 kg) bag Part C (Aggregate)All components are packaged in a 6 gallon plastic pail
- 216.6 lb unit (98.2 kg) (1.7 ft³ [0.05 m³])
 - 22.0 lb (10.0 kg) pail Part A
 - 6.6 lb (3.0 kg) bottle Part B
 - 4 x 47 lb (21.3 kg) bags Part CAll components packaged separately.

May be ordered as a 3-bag unit, which will yield 1.4 ft³ (0.04 m³). When estimating project requirements, be sure to account for application variables.

STORAGE

Store in unopened containers at 60 to 80°F (16 to 27° C) in clean, dry conditions.

SHELF LIFE

2 years when properly stored

VOC CONTENT

0 g/L less water and exempt solvents

DESCRIPTION

MasterFlow 648 is an epoxy resin-based precision grout used to secure critical equipment for proper alignment and transmission of static and dynamic loads. With carefully balanced physical properties and excellent resistance to chemical attack, elevated service temperatures, vibration and torque, MasterFlow 648 is formulated for easy installation, with good flow characteristics suitable for pouring or pumping, low dust generation and soap and water cleanup.

MasterFlow 648 is available in all regions of the world, supported by trained Master Builders Solutions Construction Chemicals sales and technical personnel with experience in the specification and installation of epoxy grouts on every continent.

PRODUCT HIGHLIGHTS

- High early and ultimate strengths for rapid turnaround
- Low creep maintains equipment alignment
- Retains physical properties at elevated temperatures increasing the service range
- Low-dusting for added worker comfort and safety
- Very low shrinkage for full baseplate contact and load transfer
- Excellent flowability with high bearing area for even load distribution
- Variable fill ratio for desired flowability
- Excellent adhesion to steel and concrete for optimum load transfer and vibration dampening
- Good chemical resistance enables use in challenging environments
- Excellent freeze/thaw resistance for equipment in low temperature service environments
- Resists water and chloride intrusion for use in wet and aggressive environments
- Resists impact and dampens torque to protect equipment and extend service life
- Extended working time
- Pumpable for maximum productivity on large grout installations.
- Durable bond to concrete and steel optimizes load transfer
- Globally available for consistent project results

APPLICATIONS

- Precision alignment of compressors, generators, pumps, fans and electric motors
- Pour-back grouting for post-tensioning cables
- Sole plates
- Crane rail grouting
- Grouting of rolling, stamping, grinding, crushing, drawing and finishing mills, forging hammers and other equipment subject to high torque, impact and vibration
- Grouting of wind turbine tower bases
- Grouting of anchors, bars and dowels

INDUSTRIES

- Chemical processing
- Oil and Gas extraction, refining, processing and distribution
- Power generation
- LNG production, storage and transmission
- Pulp and paper production
- Steel and aluminum manufacturing
- Mining
- Other heavy industry

Technical Data

Composition

MasterFlow 648 grout is three-component modified epoxy-resin-based grout.

Test Data

PROPERTY	RESULTS		TEST METHOD
Compressive strength, psi (MPa)			ASTM C 579, Method B
Consistency (Fill Ratio)	7 Day Ambient	Post Cured*	
4-Bag Mix (6.55:1)	14,500 (100)	16,000 (110)	
3-Bag Mix (4.92:1)	14,000 (96)	15,000 (103)	
Cure rate, filled 6.55:1			ASTM C 579 Method B
Compressive Strength, psi (MPa), when cured at:			
Time	50° F (10° C)	77° F (25° C)	90° F (32° C)
24 Hours	4,700 (32)	10,800 (75)	12,700 (88)
2 Days	10,000 (69)	12,100 (83)	13,200 (91)
3 Days	11,000 (76)	13,000 (90)	13,600 (94)
4 Days	12,000 (83)	13,400 (92)	13,900 (96)
Flexural modulus,* psi (GPa)			ASTM C 580
Consistency (Fill Ratio)	73° F (23° C)		
4-Bag Mix (6.55:1)	2.5 x 10 ⁶ (17.2)		
3-Bag Mix (4.92:1)	2.3 x 10 ⁶ (15.9)		
Flexural strength,* psi (MPa)			ASTM C 580
Consistency (Fill Ratio)	73° F (23° C)		
4-Bag Mix (6.55:1)	4,700 (32)		
3-Bag Mix (4.92:1)	4,300 (30)		
*Cured 24 hours at room temperature, post cured 16 hours at 140° F, and conditioned 24 hours at test temperature.			
Flow Times and Bearing Area	Back of Box	Full Plate Contact	ASTM C1339 Bearing Area
4-Bag Mix (6.55:1)			
1" Clearance	11 min.	13 min.	High (>85%)
2" Clearance	4 min., 45 sec.	5 min.	High (>85%)
Creep, in/in (cm/cm)			ASTM C 1181, 140° F (60° C), 28 days
Consistency (Fill Ratio)	400 psi (2.8 MPa) load		600 psi (4.1 MPa) load
4-Bag Mix (6.55:1)	3.8 x 10 ⁻³		4.2 x 10 ⁻³
3-Bag Mix (4.92:1)	4.0 x 10 ⁻³		4.9 x 10 ⁻³
Tensile strength, psi (MPa)			ASTM C 307
Consistency (Fill Ratio)			
4-Bag Mix (6.55:1)	2,000 (13.8)		
3-Bag Mix (4.92:1)	1,800 (12.4)		
Coefficient of thermal expansion,			ASTM C 531
73–210° F (23–99° C), in/in/° F (cm/cm/° C)			
Consistency (Fill Ratio)			
4-Bag Mix(6.55:1)	18 x 10 ⁻⁶ (32.2 x 10 ⁻⁶)		
3-Bag Mix (4.92:1)	20 x 10 ⁻⁶ (36 x 10 ⁻⁶)		
Shrinkage, unrestrained; linear, %,			ASTM C 531
Consistency (Fill Ratio)			
4-Bag Mix (6.55:1)	0.014		
3-Bag Mix (4.92:1)	0.031		

Fill Ratio Guideline

TEMPERATURE	1.7 FT ³ UNIT VERY THIN POURS OR VERY LONG DISTANCES	STANDARD POURS
> 90 °F (> 32 °C)	—	—
70 to 90 °F (21 to 32 °C)	Up to ½ bag	—
50 to 70 °F (10 to 21 °C)	½ to 1 bag	½ bag

The chart above provides guidelines for the amount of aggregate that can be removed from a 1.7 ft³ unit in order to optimize flow and cost per ft³. A maximum of 12 lbs of aggregate can be removed from a 0.4 ft³ unit.

HOW TO APPLY

SURFACE PREPARATION

1. Cure the foundation until design strength of the concrete is achieved and foundation is dry. Use the recommended procedure according to ACI 351.1R, Grouting Between Foundations and Bases for Support of Equipment and Machinery.
2. The surface to be grouted must be clean, strong, and roughened to a CSP of 5–9, following ICRI Technical Guideline No. 310.2 to permit proper bond. Do not use a bushing hammer.
3. Chamfer the edge of the concrete 45 degrees to about a 2" (51mm) width.

Figure 1 - Regular Equipment

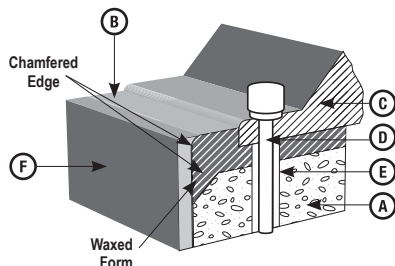

Key:

- | | |
|------------------------|----------------------------|
| A. Concrete Foundation | D. Anchor Bolt |
| B. Grout | E. Anchor Bolt Sleeve Seal |
| C. Equipment Base | F. Form |

4. If an anchor bolt sleeve is to be filled, be sure all water is removed. Use a siphon, vacuum pump, or rubber hose and bulb. Remove the residual moisture by either forced air or evaporation.

Test Data, continued

PROPERTY	RESULTS	TEST METHOD
Bond strength to steel, shear, psi (MPa), at 73° F (23° C)	2,000 (14)	Michigan DOT
Density, lb/ft³ (kg/m³)		ASTM C 905
4-Bag Mix (6.55:1)	130 (2,084)	
3-Bag Mix (4.92:1)	123 (1,971)	
Impact strength	Better than concrete	
Abrasion resistance	Better than concrete	
Flash points, ° F (° C)		Pensky-Martens Closed Cup
Masterflow 648 Part A (Resin)	419 (215)	
Masterflow 648 Part B (Hardener)	325 (163)	

All data shown is typical and representative of properties of actual production runs.

Chemical Resistance

Masterflow 648 grout resists nonoxidizing mineral acids and salts, caustics, dilute oxidizing acids and salts, plus some organic acids and solvents. For more specific information, see the MasterFlow Epoxy Grouts Chemical Resistance Guide, or contact your Master Builders Solutions representative.

5. Seal the anchor bolt hole with felt, foam rubber, or other means.
6. Cover all shims and leveling screws with putty or clay to keep the grout from adhering. Use model clay, glazing putty, or anything with a putty consistency that will stick but not harden. Shims or jack pockets may be formed with wood, and forms filled with damp sand.
7. Remove shims or jack screws after the grout cures.
8. Shade the foundation from direct sunlight for at least 24 hours before and 48 hours after grouting.

EQUIPMENT

1. If rust scale is present, abrade the bonding surfaces of the base to be grouted; it must be free of coatings, wax, grease, or scale. Mechanical methods, such as grinding or sanding, will suffice, but do not produce as high a bond strength as sandblasting.
2. Primer should be used ONLY when a long delay between cleaning and grouting could allow excessive rusting or contamination. If the base must be primed, use MasterEmaco ADH 1090 RS from Master Builders Solutions. If the primer has been on the surface for more than 1 month, abrade and solvent wipe it so that no residue remains.
3. The grout should come up at least ¾" (19 mm) onto the equipment. Protect the area above it with masking tape.
4. To facilitate cleanup, wax or cover all surfaces where the grout may splash or spill.

FORMING

1. Protect the foundation and equipment from rain or moisture. Water will prevent grout bond and inhibit cure.
2. Seal off areas that will not be grouted.
3. Place forms no greater than 6" (152 mm) away from the edge of the individual base rail or sole-plate on the sides where the grout is not being poured. Excessive edges create thermal stress and result in excessive cracking. On the pouring side forms are typically 2–6" (51–152 mm) from the edge of the supporting area. However, this may vary depending on the application. Moderate to large-size equipment and difficult or narrow placement applications should utilize an extended head form (headbox) to create additional head pressure and to enhance placement. Consult your Master Builders Solutions representative for specific recommendations.
4. Before erecting the forms, cover them with extra-heavy coats of paste wax. Forms can be shellacked before waxing to improve release. Keep wax off concrete and steel surfaces. As an alternative to waxing, a polyethylene or other non-bondable film may be used as a release agent. The top of the form should extend at least ¾" (19 mm) above the bottom of the rail or plate.
5. Forms must be liquid tight. Seal forms to vertical concrete surface by applying putty, foam, or caulk below top of concrete and then press form into place.
6. Expansion joints will reduce the possibility of cracking. On multiple soleplate installations, each soleplate may be isolated. Expansion joints can be made with any material that is resistant to oils and chemicals in the environment and will not allow penetration to the concrete foundation. Oil resistant, closed-cell foam works best. For more information contact your Master Builders Solutions representative or Technical Service.

DEEP POUR RECOMMENDATIONS

Masterflow 648 can be used for deep pours. When pour thickness will exceed six inches (150 mm) or mass exceeds 20 ft³ (0.57 m³), follow these procedures.

1. $\frac{3}{8}$ – $\frac{1}{2}$ " (9.5–13 mm) rebar on 8–12" (203 to 305 mm) centers may be used to minimize stress cracking. Locate a bottom tier about 2" (51 mm) above the foundation surface. Space additional tiers, if required, at equal distances in the grout pour, with vertical supports as required. All rebar must be 2" (51 mm) from any grout surface. For detailed information: see Master Builders Solutions technical bulletin "Reinforcing Bar Installation in Epoxy Grouts" or contact Master Builders Solutions Technical Service.
2. Let existing rebar protrude from the foundation on 12–18" (305–457 mm) centers around the perimeter and about 6–12" (152–305 mm) in from the edge. This will tie the deep pour to the foundation. The first pour should be within 2–3" (51–76 mm) of the bottom of the base. The final pour should not be made until the first pour is hard and has returned to ambient temperature, usually within 24–30 hours. (See Technical Data Guide for more information)
3. For deep-pour applications or situations that preclude the installation of rebar, consider using Masterflow 678 by Master Builders Solutions.

MIXING

1. Aggregate must be completely dry.
2. Precondition all components to 70° F (21° C) for 24 hours before using.
3. Pour the hardener (Part B) into a pail of grout resin (Part A) and stir by hand with a spatula or paint stir paddle until well mixed to a uniform amber color.
4. Pour the mixture into a horizontal shaft mortar mixer or a Kol type mixer without delay.
5. Add the grout aggregate, one bag at a time, and mix only until aggregate is completely wetted out to avoid air entrapment. The first batch may be slightly less fluid than later batches because some of the resin is retained on the walls of the mixer. Withholding $\frac{1}{2}$ –1 bag of aggregate from the first batch of a full unit will compensate for lost resin. Note: always add aggregate to the mixer after the premixed liquids have been poured in.

6. Adjust the amount of aggregate used for the temperature and type of pour. The temperature of the grout, foundation, and equipment base are more important than the air temperature because they will affect the grout flow rate. The required flow is related to the grout thickness (between the foundation and base) and the flow distance.

PUMPING MASTERFLOW 648

- Condition all grouting materials as close to 70° F (21.1° C) as possible. If an accelerator is used, a grout temperature of 60–65° F (15.6–18.3° C) is acceptable.
- Proper equipment is critical to successful pumping of epoxy grouts. Peristaltic and piston pumps are recommended.
- Grout should be pumped through the shortest distance possible. The maximum distance should be limited to 50 ft (15.2 m)
- For pumping distances greater than 10 ft (3 m), a 1- $\frac{1}{2}$ in (38 mm) diameter, PVC pipe should be used to convey grout from the pump outlet to the base of the equipment being grouted. A flexible, seamless, clear vinyl hose should be attached to the end of the PVC pipe to manipulate the grout into the grouting holes or around the forms.
- Prime the pump and pump lines with the neat epoxy resin or vegetable oil. Never prime the pump and hose with water or any other material that can contaminate the epoxy grout. Purge the pump, pipe and hose of all priming material prior to pumping the grout.
- High flow mixes (three bags of aggregate per full units of resin and hardener) are much easier to pump than fully loaded mixes (four bags of aggregate). Jobsite and weather conditions will influence the aggregate loading that can be pumped successfully. Never use less than three bags or more than four bags of aggregate fill per full unit of resin and hardener.
- Regardless of required aggregate fill ratio, begin pumping with a three-bag mix, to ensure wet-out of the pump and lines. If a four-bag mix is desired, the aggregate loading should be increased on subsequent mixes in half bag increments.
- Once the grouting operation begins do not allow the pump to run out of material until the piece of equipment is completely grouted.
- Install the tip of the pump line through the grout holes in the equipment or between the

formwork and the baseplate. Try to keep the tip of the grout line in sight whenever possible. Keep the pump line submerged in the grout and slowly withdraw it as the grout fills up under the application area. Avoid creating air pockets at all times.

- As the grout fills the space beneath the baseplate, and can be seen at the next grout hole or at the edge of the formwork on the opposite side, move the pump line to the next grout hole or down the length of the form and continue pumping.
- The pump and hose should be cleaned every 1- $\frac{1}{2}$ to 2 hours. If cleaned more frequently, soap and water will be effective; otherwise, a citrus degreaser should be used and followed with a final flush using vegetable oil.
- When the installation is complete, immediately clean the pump and lines.

*Contact the pump equipment manufacturer for additional information on the use and operation of their pumps.

PLACEMENT

1. Pour the grout into a wheelbarrow or buckets for transporting to pour-site. Remove it from the wheelbarrow within 15 minutes.
2. For flat bottom plates and bases, pour the grout from one side through to the other across the short dimension.
3. When grouting closed areas, prevent air entrapment by starting at one end of the form and filling the cavity completely while advancing toward the other end.
4. Masterflow 648 grout will flow, but it can be aided with pushing tools like banding straps or plywood strips. Push with long, slow strokes rather than short jabs until no air pockets remain under the frames. DO NOT VIBRATE.
5. Where grout cannot be adequately worked to fill the cavity (because of large size or limited space), a head box will greatly assist flow. Use a sturdy wooden box or sheet metal funnel about 1–2 ft (0.3–0.6 m) tall.
6. Check frequently for leaks. Leaks do not self-seal. If not stopped, they will cause voids.
7. If a multi-pour installation is necessary, sprinkle a small amount of MasterFlow 648 aggregate on the first pour's surface as the grout solidifies. Before placement of the second pour, brush the loose aggregate from the first pour's surface. Another method is to sandblast and brush clean the first pour's surface.

CLEANUP

After the pour is complete, remove uncured epoxy from the mixer, wheelbarrow and tools with soap and water or a citrus degreaser. Cured material must be removed mechanically.

WORKING TIME

The following chart shows the working time for a fresh grout mix at various ambient temperatures. The working time begins when the hardener is added to the resin. **Do not let resin and hardener stand without adding aggregate.** This material produces an exothermic. If the material exotherms without aggregate, the temperature can cause decomposition or gassing, releasing potentially hazardous fumes. If the catalyzed resin cannot be used immediately, spread the material over a large open surface, which will allow the heat to dissipate normally. These working times assume product has been properly preconditioned for cold or hot weather use.

Working Time

TEMPERATURE, °F (° C)	MINUTES
90 (32)	50–60
70 (21)	90–120
50 (10)	120–150

COLD-WEATHER CURING

For cold weather grouting use Masterflow 640 Accelerator. Refer to the Masterflow 640 Accelerator data sheet.

- The foundation and the equipment base will probably be cooler than room temperature unless room temperature has been constant for some time. Use the foundation and engine temperature, therefore, in estimating cure time.
- Temperatures vary so radically, day vs. night, atmospheric vs. metal surface, that field judgment must still be used as the final measure. Cured grout should have a solid, almost metallic feel when struck with a hammer. Be sure to check as close to the base of the equipment as possible.

HOT-WEATHER GROUTING

- Special care must be exercised when grouting at elevated temperatures, to reduce risks of premature hardening and subsequent cracking.
- If the packaged grout is above 90° F (32° C), chill the sealed pails of grout resin in a tub of ice or cover the pails with water-soaked burlap to cool the grout to 70° F (21° C).
- Provide shade from direct sunlight for at least 24 hours before and 48 hours after grouting.

COLD-WEATHER GROUTING

- Temperatures below 60° F (16° C) make the grout stiff and hard to handle and significantly increase the cure time. The baseplate and foundation may be much cooler than room temperature. In cold weather, store materials in a warm place. For best handling, the temperature of the grout components and mixing equipment should be at least 70° F (21° C).
- When baseplate and foundation temperatures (measured by a contact thermometer) are less than 50° F (10° C), heating of the area may be necessary.
- If heating is required, erect an enclosure around the equipment and foundation to be grouted. Forced air or infrared heaters may be used to obtain the necessary heat to increase the baseplate and foundation temperatures to 50 to 70° F (10 to 21° C). Avoid local hot spots. Apply heat 1–2 days in advance of grouting to achieve uniform baseplate and foundation temperatures. Avoid exposure to exhaust from heating equipment. Remove heat during grout placement.
- For temperatures from 40 to 50° F (4 to 10° C), consider using Masterflow 640 Grout Accelerator to accelerate strength development.

FILL RATIO

- The fill ratio is the weight of aggregate compared to the combined resin and hardener components. Masterflow 648 is used at a variable fill ratio from the standard 6.55:1 ratio to as low as 4.92:1 (high-flow version).
- The standard 1.7 ft³ (0.04 m³) unit of Masterflow 648 includes 188 lbs (85.2 kg) of aggregate (or four 47 lb bags). This 6.55:1 fill ratio can be reduced to as low as three bags or a 4.92:1 fill ratio yielding 1.4 ft³ (0.04 m³).

- For projects requiring a fill ratio different from the standard 4 bag mix, simply determine how many bags of aggregate will be used (number of bags x number of units) and purchase the components (resin, hardener, and aggregate) separately. When using Masterflow 648 in post-tensioning anchorages, always use the standard aggregate load of 6.55:1.

Fill Ratio Guideline

TEMPERATURE	1.7 FT ³ UNIT	
	VERY THIN POURS OR VERY LONG DISTANCES	STANDARD POURS
> 90° F (> 32° C)	—	—
70 to 90° F (21 to 32° C)	Up to ½ bag	—
50 to 70° F (10 to 21° C)	½ to 1 bag	½ bag

The chart above provides guidelines for the amount of aggregate that can be removed from a 1.7 ft³ unit in order to optimize flow and cost per ft³. A maximum of 12 lbs of aggregate can be removed from a 0.4 ft³ unit.

WASTE DISPOSAL METHOD

This product when discarded or disposed of, is not listed as a hazardous waste in federal regulations. Dispose of in a landfill in accordance with local regulations. For additional information on personal protective equipment, first aid, and emergency procedures, refer to the product Safety Data Sheet (SDS) on the job site or contact the company at the address or phone numbers given below.

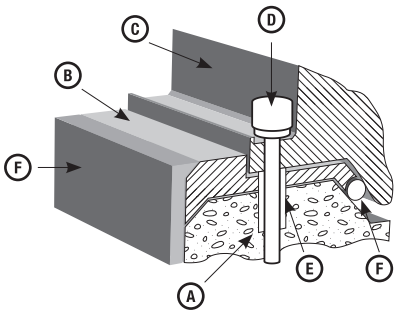

Figure 2 - Engine with Oil Pan

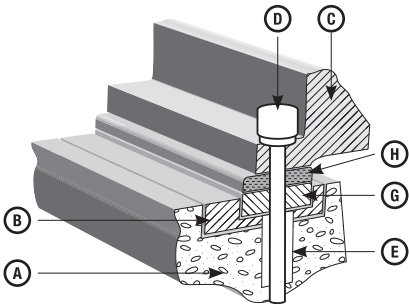

Figure 3 - Rail or Soleplate

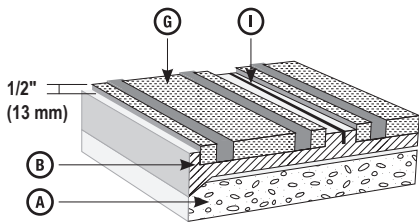

Figure 4 - Typical Rail With Expansion Joint Section

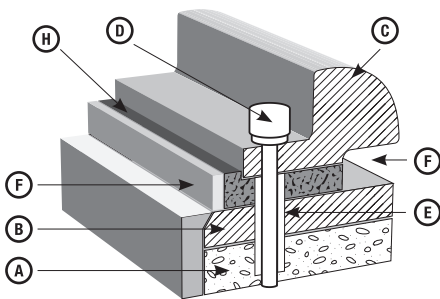

Figure 5 - Typical Epoxy Chock Application

Key

- | | |
|----------------------------|----------------------|
| A. Concrete Foundation | F. Form |
| B. Grout | G. Soleplate or Rail |
| C. Equipment Base | H. Shim or Chock |
| D. Anchor Bolt | I. Expansion Joint |
| E. Anchor Bolt Sleeve Seal | |

FOR BEST PERFORMANCE

- Do not add solvent, water, or any other material to the grout.
- Do not alter the resin or hardener proportions.
- Contact your local representative for a pre-job conference to plan the installation.
- For guidelines on specific anchor-bolt applications, contact Technical Service.
- Always use a head box when placing less than 1" (25 mm) depths.
- Substrate temperature must be greater than 50° F (10° C).
- Cold material will exhibit decreased flowability and reduced strength development.
- When using MasterFlow 648 in post-tensioning anchorages, always use the standard aggregate load of 6.55:1.
- Minimum placement thickness is ½" (13 mm). Consult your Master Builders Solutions representative before placing lifts more than 6" (152 mm) in depth.
- Chamfering the concrete edge helps reduce thermal cracking. Following proper installation procedures also reduces the potential for cracking.
- For professional use only; not for sale to or use by the general public.
- Make certain the most current versions of product data sheet and SDS are being used; visit www.master-builders-solutions.com/en-us to verify the most current versions.
- Proper application is the responsibility of the user. Field visits by Master Builders Solutions personnel are for the purpose of making technical recommendations only and not for supervising or providing quality control on the jobsite.

HEALTH, SAFETY AND ENVIRONMENTAL

Read, understand and follow all Safety Data Sheets and product label information for this product prior to use. The SDS can be obtained by visiting www.master-builders-solutions.com/en-us, e-mailing your request to mbsbscst@mbcc-group.com, or calling 1(800)433-9517. Use only as directed.

IN CASE OF EMERGENCY: Call CHEMTEL +1 (800) 255-3924 or if outside the US or Canada, +1 (813) 248-0585.

LIMITED WARRANTY NOTICE

Master Builders Solutions Construction Systems US, LLC (“Master Builders”) warrants this product to be free from manufacturing defects and to meet the technical properties on the current Technical Data Guide, if used as directed within shelf life. Satisfactory results depend not only on quality products but also upon many factors beyond our control. MASTER BUILDERS MAKES NO OTHER WARRANTY OR GUARANTEE, EXPRESS OR IMPLIED, INCLUDING WARRANTIES OF MERCHANTABILITY OR FITNESS FOR A PARTICULAR PURPOSE WITH RESPECT TO ITS PRODUCTS. The sole and exclusive remedy of Purchaser for any claim concerning this product, including but not limited to, claims alleging breach of warranty, negligence, strict liability or otherwise, is shipment to purchaser of product equal to the amount of product that fails to meet this warranty or refund of the original purchase price of product that fails to meet this warranty, at the sole option of Master Builders. Any claims concerning this product must be received in writing within one (1) year from the date of shipment and any claims not presented within that period are waived by Purchaser. MASTER BUILDERS WILL NOT BE RESPONSIBLE FOR ANY SPECIAL, INCIDENTAL, CONSEQUENTIAL (INCLUDING LOST PROFITS) OR PUNITIVE DAMAGES OF ANY KIND.

Purchaser must determine the suitability of the products for the intended use and assumes all risks and liabilities in connection therewith. This information and all further technical advice are based on Master Builders’ present knowledge and experience. However, Master Builders assumes no liability for providing such information and advice including the extent to which such information and advice may relate to existing third party intellectual property rights, especially patent rights, nor shall any legal relationship be created by or arise from the provision of such information and advice. Master Builders reserves the right to make any changes according to technological progress or further developments. The Purchaser of the Product(s) must test the product(s) for suitability for the intended application and purpose before proceeding with a full application of the product(s). Performance of the product described herein should be verified by testing and carried out by qualified experts.

FOR PROFESSIONAL USE ONLY. NOT FOR SALE TO OR USE BY THE GENERAL PUBLIC.