

Structural Studs & Track

Industry standard nomenclature is used to identify MBA's products. The Steel Framing Industry Association has established standard designation codes for structural studs and track. In each case, the identification starts with the measurement of the width of the member, followed by a letter (S = stud and T = track) followed by the flange dimension. A hyphen is used to separate all of this from the thickness of the metal.

Member Depth:

(Example: 6" = 600 x 1/100 inches)

All member depths are taken in 1/100 inches. For all "T" sections member depth is the inside to inside dimension.

Flange Width:

(Example: 1 5/8" = 1.625" 162 x 1/100 inches)

All flange widths are taken in 1/100 inches.

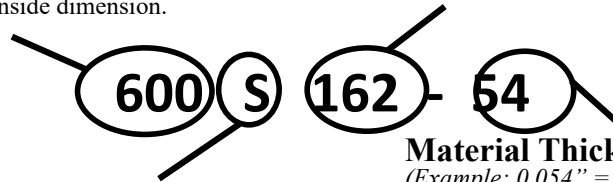

Style:

(Example: Stud or Joist Section = S)

Relevant alpha characters utilized by the designation system are:

S = Stud or Joist Sections T = Track Sections

Material Thickness:

(Example: 0.054" = 54 mils; 1 mil = 1/1000 in.)

Material thickness is the minimum base metal thickness in mils.

Minimum base metal thickness represents 95% of the design thickness.

Steel Thickness

Mils	Gauge	Thickness (in)	
		Design	Minimum ¹
33	20	0.0346	0.0329
43	18	0.0451	0.0428
54	16	0.0566	0.0538
68	14	0.0713	0.0677
97	12	0.1017	0.0966
118	10	0.1242	0.1180

¹ Minimum Thickness represents 95% of the design thickness and is the minimum acceptable thickness delivered to the job site based on AISI S100-16/S2-20.

Design Stiffening Lip Length

Section	Flange Width	Design Stiffening Lip Length (in)
S137	1-3/8"	0.375
S162	1-5/8"	0.500
S200	2"	0.625
S250	2-1/2"	0.625
S300	3"	1.000
S350	3-1/2"	1.000

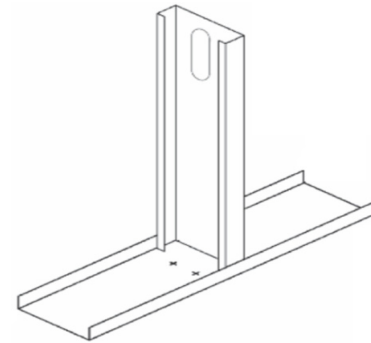

Structural Stud Punchouts

Punchouts for structural studs are ovals. These punchouts begin 12" from the lead end and are spaced at 24" o.c. intervals. The last punchout is 12" minimum from the trailing end of the stud. Care should be taken during installation to be sure the studs are oriented in the same direction to facilitate plumbing and electrical installation.

General Notes

- Physical properties and load tables have been calculated in conformance with the AISI S100-16/S2-20.
- All structural framing members have a protective coating conforming to ASTM C 955.
- Reference ASTM specification A 1003/A 1003 M table 1 for the universe of allowable coatings for light gauge steel framing.
- Stud/joists are manufactured to custom lengths. Stud/joists are manufactured with punched webs unless otherwise specified at time of order.
- Track is produced in standard lengths of 10 feet unless a custom track length is indicated. Track is manufactured with unpunched webs.
- Structural framing members are marked with product information per the requirements of ASTM C 955 section 12.
- All delivered material must be kept dry, preferably by being stored inside a building under a roof. If it is necessary to store material outside, it must be stacked off the ground, properly supported on a level platform, and fully protected from the weather. Reference ASTM C 754 section 8 and ASTM C 1007 section 4.

LEED Green Building Credits

MR Credit 2: Construction Waste Management – MBA steel framing is 100% recyclable.

MR Credit 4: Recycled Content – MBA steel framing is formed from no less than 25.5% post-consumer and 6.8% pre-consumer recycled content.

MR Credit 5: Regional Materials – MBA has manufacturing facilities in multiple states.

Section Properties

Section Properties Table Notes

1. Web depth for track sections is equal to the nominal height plus 2 times design thickness plus the bend radius.
2. Effective properties incorporate the strength increase from the cold work of forming as applicable per the AISI S100-16/S2-20.
3. Tabulated gross properties are based on the full, unreduced section away from punchouts.
4. Effective properties of all 'S' sections based on punched sections. Track sections are considered unpunched.
5. For deflection calculations, use the effective moment of inertia.
6. Where effective properties are not listed for a section at 33 or 50 ksi yield, web depth-to-thickness or flange width-to-thickness limits from the AISI are exceeded. Only gross properties are available.

Structural (S) Stud Section Properties

Section	Design Thickness (in)	Gross Properties						Effective Properties (33ksi)						Effective 50ksi						Torsional									
		Area (in ²)	Weight (lb/ft)	I _x (in ⁴)	S _x (in ³)	R _x (in)	I _y (in ⁴)	R _y (in)	I _x (in ⁴)	S _x (in ³)	M _a	(in-k)	Vag	(lb)	Vanet	(lb)	I _{xx} (in ⁴)	S _{xx} (in ³)	M _a	(in-k)	Vag	(lb)	Vanet	(lb)	J ¹⁰⁰⁰ (in ⁴)	C _w (in ²)	X _o (in)	X _o (in)	m (in)
250S137-33	0.0346	0.197	0.67	0.203	0.163	1.015	0.052	0.515	0.203	0.158	3.11	975	399											0.079	0.076	-1.141	0.677	1.612	0.499
250S137-43	0.0451	0.255	0.87	0.261	0.208	1.01	0.067	0.511	0.261	0.205	4.53 ¹	1265	394										0.173	0.096	-1.129	0.67	1.599	0.501	
250S137-54	0.0566	0.316	1.07	0.318	0.255	1.004	0.08	0.504	0.318	0.255	5.76 ¹	1553	373	0.318	0.244	8.22 ²	2353	565	0.337	0.115	-1.115	0.663	1.583	0.504					
250S137-68	0.0713	0.39	1.33	0.386	0.309	0.994	0.095	0.495	0.386	0.309	7.19 ¹	1891	342	0.386	0.308	10.65 ²	2866	519	0.661	0.138	-1.096	0.653	1.561	0.507					
250S162-33	0.0346	0.223	0.76	0.235	0.188	1.027	0.087	0.624	0.235	0.18	3.55	975	399										0.089	0.146	-1.47	0.859	1.898	0.401	
250S162-43	0.0451	0.289	0.98	0.302	0.242	1.022	0.111	0.62	0.302	0.24	5.22 ²	1265	394										0.196	0.184	-1.457	0.852	1.885	0.402	
250S162-54	0.0566	0.358	1.22	0.37	0.296	1.016	0.135	0.613	0.37	0.296	6.57 ¹	1553	373	0.37	0.284	9.42 ²	2353	565	0.383	0.223	-1.443	0.845	1.868	0.403					
250S162-68	0.0713	0.443	1.51	0.45	0.36	1.007	0.162	0.605	0.45	0.36	8.21 ¹	1891	342	0.45	0.357	12.11 ¹	2866	519	0.752	0.268	-1.424	0.835	1.846	0.405					
350S162-33	0.0346	0.258	0.88	0.508	0.29	1.404	0.098	0.617	0.508	0.257	5.08	1024	487										0.103	0.277	-1.324	0.796	2.036	0.573	
350S162-43	0.0451	0.334	1.14	0.654	0.374	1.4	0.125	0.612	0.654	0.357	7.05	1739	631										0.227	0.35	-1.312	0.789	2.014	0.575	
350S162-54	0.0566	0.415	1.41	0.804	0.46	1.392	0.152	0.606	0.804	0.447	8.83	2353	633	0.804	0.426	12.74	3372	947	0.443	0.426	-1.298	0.782	1.998	0.578					
350S162-68	0.0713	0.515	1.75	0.985	0.563	1.383	0.184	0.597	0.985	0.551	10.89	2774	592	0.985	0.549	16.44	4202	897	0.872	0.514	-1.28	0.772	1.977	0.581					
362S137-33	0.0346	0.236	0.8	0.479	0.264	1.424	0.059	0.501	0.479	0.232	4.59	1024	521										0.094	0.165	-1.003	0.615	1.813	0.694	
362S137-43	0.0451	0.306	1.04	0.616	0.34	1.419	0.075	0.497	0.616	0.32	6.32	1739	676										0.207	0.208	-0.991	0.608	1.801	0.697	
362S137-54	0.0566	0.379	1.29	0.756	0.417	1.411	0.091	0.48	0.756	0.402	7.94	2341	705	0.756	0.381	11.42	3372	1016	0.405	0.251	-0.978	0.601	1.785	0.7					
362S137-68	0.0713	0.47	1.6	0.922	0.509	1.401	0.109	0.49	0.922	0.498	9.84	2884	662	0.922	0.493	14.77	4370	1004	0.797	0.302	-0.959	0.592	1.764	0.704					
362S162-33	0.0346	0.262	0.89	0.551	0.304	1.45	0.099	0.616	0.551	0.268	5.29	1024	521										0.105	0.297	-1.308	0.789	2.048	0.592	
362S162-43	0.0451	0.34	1.16	0.71	0.392	1.445	0.127	0.611	0.71	0.372	7.34	1739	676										0.23	0.376	-1.297	0.782	2.036	0.594	
362S162-54	0.0566	0.422	1.44	0.873	0.481	1.438	0.154	0.604	0.873	0.466	9.22	2341	705	0.873	0.444	13.28	3372	1016	0.451	0.457	-1.283	0.774	2.02	0.597					
362S162-68	0.0713	0.524	1.78	1.069	0.59	1.429	0.186	0.596	1.069	0.579	11.43	2884	662	1.069	0.574	17.18	4370	1004	0.884	0.552	-1.264	0.765	1.998	0.6					
362S200-33	0.0346	0.297	1.01	0.648	0.358	1.478	0.177	0.772	0.647	0.294	5.81	1024	521										0.118	0.577	-1.741	1.03	2.411	0.478	
362S200-43	0.0451	0.385	1.31	0.836	0.461	1.474	0.227	0.767	0.836	0.427	8.43	1739	676										0.261	0.734	-1.729	1.024	2.398	0.48	
362S200-54	0.0566	0.479	1.63	1.03	0.568	1.467	0.277	0.761	1.03	0.553	10.93	2341	705	1.03	0.49	14.66	3372	1016	0.511	0.896	-1.715	1.016	2.382	0.482					
362S200-68	0.0713	0.595	2.02	1.265	0.698	1.458	0.337	0.753	1.265	0.687	13.58	2884	662	1.265	0.666	19.95	4370	1004	1.008	1.089	-1.696	1.006	2.36	0.484					
400S137-33	0.0346	0.249	0.85	0.603	0.301	1.556	0.061	0.496	0.603	0.259	5.12	976	595										0.099	0.204	-0.965	0.597	1.897	0.741	
400S137-43	0.0451	0.323	1.1	0.776	0.388	1.551	0.078	0.491	0.776	0.359	7.09	1739	810										0.219	0.257	-0.954	0.591	1.885	0.744	
400S137-54	0.0566	0.401	1.36	0.953	0.477	1.542	0.094	0.484	0.953	0.453	8.96	2603	944	0.953	0.428	12.82	3372	1223	0.428	0.311	-0.94	0.583	1.87	0.747					
400S137-68	0.0713	0.497	1.69	1.165	0.582	1.531	0.112	0.475	1.165	0.567	11.21	3215	895	1.165	0.558	16.7	4871	1956	0.842	0.375	-0.922	0.574	1.849	0.751					
400S162-33	0.0346	0.275	0.94	0.692	0.346	1.586	0.103	0.611	0.692	0.299	5.91	976	595										0.11	0.363	-1.263	0.768	2.118	0.644	
400S162-43	0.0451	0.357	1.21	0.892	0.446	1.581	0.131	0.606	0.892	0.417	8.23	1739	810										0.242	0.46	-1.252	0.761	2.106	0.647	
400S162-54	0.0566	0.443	1.51	1.098	0.549	1.574	0.159	0.6	1.098	0.526	10.39	2603	944	1.098	0.498	14.9	3372	1223	0.473	0.56	-1.238	0.754	2.09	0.649					
400S162-68	0.0713	0.55	1.87	1.346	0.673	1.564	0.192	0.591	1.346	0.658	13	3215	895	1.346	0.648	19.41	4871	1956	0.933	0.677	-1.22	0.745	2.069	0.653					
400S200-33	0.0346	0.31	1.05	0.812	0.406	1.619	0.183	0.769	0.812	0.328	6.49	976	595										0.124	0.697	-1.688	1.007	2.462	0.53	
400S200-43	0.0451	0.402	1.37	1.047	0.524	1.615	0.235	0.764	1.047	0.478	9.45	1739	810										0.272	0.886	-1.676	1	2.449	0.532	
400S200-54	0.0566	0.5	1.7	1.292	0.646	1.608	0.287	0.758	1.292	0.623	12.3	2603	944	1.292	0.549	16.43	3372	1223	0.534	1.083	-1.662	0.993	2.433	0.534					
400S200-68	0.0713	0.622	2.12	1.589	0.795	1.599	0.349	0.75	1.589	0.78	15.4	3215	895	1.589	0.751	22.48	4871	1956	1.054	1.318	-1.643	0.983	2.412	0.536					
550S162-33	0.0346	0.327	1.11	1.458	0.53	2.112	0.113	0.589	1.458	0.512	10.11	699	699										0.13	0.713	-1.114	0.697	2.459	0.795	
550S162-43	0.0451	0.424	1.44	1.883	0.685	2.107	0.145	0.584	1.883	0.681	14.79 ¹	1199	1199										0.288	0.905	-1.103	0.691	2.448	0.797	
550S162-54	0.0566	0.528	1.8	2.324	0.845	2.098	0.176	0.577	2.324	0.845	18.76 ¹	2739	1666	2.324	0.811	26.86 ²	3093	1881	0.564	1.105	-1.09	0.684	2.434	0.8					
550S162-68	0.0713	0.657	2.24	2.861	1.04	2.086	0.212	0.568	2.861	1.04	23.72 ¹	4347	2057	2.861	1.031	34.94 ²	5350	2532	1.114	1.342	-1.072	0.675	2.414	0.803					
600S137-33	0.0346	0.318	1.08	1.582	0.527	2.229	0.069	0.464	1.548	0.455	8.98	638	638										0.127	0.5	-0.807	0.519	2.416	0.889	
600S137-43	0.0451	0.413	1.41	2.042	0.681	2.223	0.087	0.459	2.041	0.645	12.74	1416	1240										0.28	0.633	-0.796	0.513	2.406	0.89	
600S137-54	0.0566	0.514	1.75	2.518	0.839	2.213	0.105	0.452	2.518	0.832	16.44	2739	1890	2.518	0.777	23.26	2823	1947	0.529	0.769	-0.784	0.506	2.391	0.893					
600S137-68	0.0713	0.64	2.18	3.094	1.031	2.2	0.125	0.443	3.094	1.031	24.05 ¹	4347	2339	3.094	1.03	30.84	5350	2879	1.084	0.93	-0.768	0.497	2.371	0.895					
600S137-97	0.1017																												

Section Properties (Continued)

Structural (S) Stud Section Properties

Section	Design Thickness (in)	Gross Properties							Effective Properties (33ksi)					Effective 50ksi					Torsional					
		Area (in ²)	Weight (lb/ft)	I _x (in ⁴)	S _x (in ³)	R _x (in)	I _y (in ⁴)	R _y (in)	I _x (in ⁴)	S _x (in ³)	Ma (in-k)	V _{ag} (lb)	V _{anet} (lb)	I _{xx} (in ⁴)	S _{xx} (in ³)	Ma (in-k)	V _{ag} (lb)	V _{anet} (lb)	J ^{x1000} (in ⁴)	C _w (in ⁶)	X _o (in)	m (in)	R _o (in)	β
600S200-33	0.0346	0.379	1.29	2.075	0.692	2.340	0.209	0.743	2.058	0.621	12.28 ²	638	638						0.151	1.593	-1.457	0.901	2.855	0.740
600S200-43	0.0451	0.492	1.67	2.683	0.894	2.335	0.268	0.739	2.683	0.873	17.24	1416	1240						0.334	2.033	-1.446	0.894	2.844	0.742
600S200-54	0.0566	0.613	2.09	3.319	1.106	2.327	0.328	0.732	3.319	1.106	24.07 ²	2739	1890	3.319	1.015	30.40	2823	1947	0.655	2.493	-1.432	0.887	2.829	0.744
600S200-68	0.0713	0.764	2.60	4.101	1.367	2.316	0.400	0.723	4.101	1.367	30.42 ²	4347	2339	4.101	1.317	43.71 ²	5350	2879	1.295	3.047	-1.415	0.878	2.809	0.746
600S200-97	0.1017	1.067	3.63	5.612	1.871	2.293	0.530	0.705	5.612	1.871	43.49 ²	6911	2512	5.612	1.871	64.53 ²	10472	3805	3.679	4.080	-1.378	0.859	2.767	0.752
600S250-43	0.0451	0.537	1.83	3.082	1.027	2.396	0.458	0.923	3.082	0.918	18.14	1416	1240						0.364	3.411	-1.874	1.136	3.179	0.652
600S250-54	0.0566	0.670	2.28	3.819	1.273	2.388	0.562	0.917	3.819	1.159	22.90	2739	1890	3.766	1.069	32.00	2823	1947	0.715	4.194	-1.860	1.129	3.163	0.654
600S250-68	0.0713	0.836	2.84	4.727	1.576	2.378	0.688	0.908	4.727	1.508	32.82 ²	4347	2339	4.723	1.386	41.49	5350	2879	1.416	5.145	-1.842	1.119	3.142	0.656
600S250-97	0.1017	1.169	3.98	6.496	2.165	2.357	0.923	0.889	6.496	2.161	48.81 ²	6911	2512	6.496	2.063	69.38 ²	10472	3805	4.030	6.947	-1.803	1.100	3.098	0.661
800S137-33 ¹	0.0346	0.388	1.32	3.198	0.799	2.873	0.073	0.435	2.998	0.622	12.30	474	474						0.155	0.957	-0.696	0.460	2.987	0.946
800S137-43	0.0451	0.503	1.71	4.134	1.033	2.866	0.093	0.430	4.001	0.896	17.70	1051	1051						0.341	1.214	-0.687	0.454	2.978	0.947
800S137-54	0.0566	0.627	2.13	5.110	1.277	2.855	0.112	0.423	5.077	1.179	23.29	2091	2091	4.974	1.083	32.42	2091	2091	0.670	1.478	-0.676	0.448	2.964	0.948
800S137-68	0.0713	0.782	2.66	6.303	1.576	2.839	0.134	0.414	6.303	1.541	30.45	4221	3367	6.285	1.468	43.96	4221	3367	1.325	1.789	-0.661	0.440	2.944	0.950
800S137-97	0.1017	1.093	3.72	8.597	2.149	2.805	0.169	0.394	8.597	2.149	53.09 ²	8843	4824	8.597	2.149	64.35	10885	5938	3.767	2.349	-0.630	0.423	2.902	0.953
800S162-33 ¹	0.0346	0.413	1.41	3.582	0.896	2.943	0.125	0.550	3.384	0.710	14.03	474	474						0.165	1.630	-0.936	0.607	3.137	0.911
800S162-43	0.0451	0.537	1.83	4.633	1.158	2.937	0.160	0.546	4.500	1.019	20.14	1051	1051						0.364	2.076	-0.926	0.601	3.128	0.912
800S162-54	0.0566	0.670	2.28	5.736	1.434	2.927	0.194	0.539	5.702	1.334	26.36	2091	2091	5.600	1.229	36.79	2091	2091	0.715	2.539	-0.914	0.594	3.113	0.914
800S162-68	0.0713	0.836	2.84	7.089	1.772	2.913	0.235	0.530	7.089	1.737	34.32	4221	3367	7.070	1.663	49.80	4221	3367	1.416	3.093	-0.899	0.586	3.094	0.916
800S162-97	0.1017	1.169	3.98	9.713	2.428	2.883	0.305	0.510	9.713	2.428	58.27 ²	8843	4824	9.713	2.428	72.70	10885	5938	4.030	4.114	-0.866	0.568	3.053	0.919
800S200-33 ¹	0.0346	0.448	1.52	4.096	1.024	3.023	0.227	0.712	4.096	0.816	16.12	474	474						0.179	2.971	-1.288	0.817	3.363	0.853
800S200-43	0.0451	0.582	1.98	5.302	1.325	3.018	0.292	0.708	5.302	1.293	25.54	1051	1051						0.395	3.797	-1.277	0.811	3.353	0.855
800S200-54	0.0566	0.726	2.47	6.573	1.643	3.009	0.357	0.701	6.573	1.643	35.75 ²	2091	2091	6.573	1.499	44.87	2091	2091	0.775	4.663	-1.265	0.804	3.338	0.856
800S200-68	0.0713	0.907	3.09	8.140	2.035	2.996	0.435	0.692	8.140	2.035	45.29 ²	4221	3367	8.140	1.964	65.21 ²	4221	3367	1.537	5.712	-1.248	0.796	3.319	0.859
800S200-97	0.1017	1.271	4.32	11.203	2.801	2.969	0.576	0.673	11.203	2.801	65.12 ²	8843	4824	11.203	2.801	96.63 ²	10885	5938	4.381	7.684	-1.214	0.777	3.278	0.863
800S250-43	0.0451	0.627	2.13	6.015	1.504	3.097	0.500	0.893	6.015	1.313	25.95	1051	1051						0.425	6.374	-1.675	1.043	3.632	0.787
800S250-54	0.0566	0.783	2.66	7.465	1.866	3.088	0.614	0.886	7.465	1.712	33.82	2091	2091	7.378	1.525	45.66	2091	2091	0.836	7.850	-1.661	1.036	3.617	0.789
800S250-68	0.0713	0.978	3.33	9.261	2.315	3.077	0.752	0.877	9.261	2.220	48.33 ²	4221	3367	9.240	2.059	61.65	4221	3367	1.658	9.652	-1.644	1.027	3.597	0.791
800S250-97	0.1017	1.372	4.67	12.789	3.197	3.053	1.009	0.857	12.789	3.191	72.07 ²	8843	4824	12.789	3.054	102.70 ²	10885	5938	4.731	13.091	-1.607	1.008	3.555	0.796
1000S162-43 ¹	0.0451	0.627	2.13	8.025	1.605	3.577	0.168	0.518	7.523	1.302	25.74	836	836						0.425	3.430	-0.823	0.545	3.707	0.951
1000S162-54	0.0566	0.783	2.66	9.950	1.990	3.565	0.204	0.511	9.627	1.722	34.02	1661	1661	9.391	1.572	47.07	1661	1661	0.836	4.198	-0.812	0.538	3.692	0.952
1000S162-68	0.0713	0.978	3.33	12.325	2.465	3.550	0.246	0.502	12.256	2.276	44.98	3345	3345	11.978	2.154	64.51	3345	3345	1.658	5.121	-0.798	0.531	3.673	0.953
1000S162-97	0.1017	1.372	4.67	16.967	3.393	3.516	0.320	0.483	16.967	3.393	67.06	8843	6434	16.967	3.269	97.89	9864	7177	4.731	6.827	-0.768	0.514	3.631	0.955
1000S200-43 ¹	0.0451	0.672	2.29	9.085	1.817	3.676	0.309	0.677	8.602	1.470	29.05	836	836						0.456	6.236	-1.147	0.743	3.910	0.914
1000S200-54	0.0566	0.839	2.86	11.278	2.256	3.666	0.378	0.671	10.953	1.984	39.20	1661	1661	10.769	1.705	51.05	1661	1661	0.896	7.665	-1.135	0.737	3.896	0.915
1000S200-68	0.0713	1.050	3.57	13.994	2.799	3.652	0.460	0.662	13.920	2.607	51.51	3345	3345	13.665	2.420	72.46	3345	3345	1.779	9.401	-1.120	0.729	3.876	0.917
1000S200-97	0.1017	1.474	5.02	19.336	3.867	3.622	0.609	0.643	19.336	3.867	76.42	8843	6434	19.336	3.741	112.00	9864	7177	5.082	12.679	-1.088	0.711	3.836	0.920
1000S250-43 ¹	0.0451	0.717	2.44	10.203	2.041	3.771	0.531	0.860	10.203	1.617	31.95	836	836						0.486	10.481	-1.518	0.965	4.155	0.867
1000S250-54	0.0566	0.896	3.05	12.677	2.535	3.762	0.653	0.854	12.677	2.277	44.99	1661	1661	12.660	1.879	56.26	1661	1661	0.957	12.922	-1.505	0.958	4.140	0.868
1000S250-68	0.0713	1.121	3.81	15.751	3.150	3.749	0.799	0.844	15.751	3.028	65.93 ²	3345	3345	15.741	2.768	82.89	3345	3345	1.899	15.909	-1.488	0.950	4.121	0.870
1000S250-97	0.1017	1.576	5.36	21.827	4.365	3.722	1.072	0.825	21.827	4.357	98.41 ²	8843	6434	21.827	4.181	140.63 ²	9864	7177	5.433	21.632	-1.454	0.932	4.080	0.873
1200S162-54 ¹	0.0566	0.896	3.05	15.730	2.622	4.190	0.212	0.486	14.743	2.109	41.68	1377	1377	14.298	1.914	57.31	1377	1377	0.957	6.340	-0.732	0.493	4.281	0.971
1200S162-68	0.0713	1.121	3.81	19.518	3.253	4.173	0.255	0.477	18.955	2.817	55.66	2771	2771	18.390	2.645	79.19	2771	2771	1.899	7.739	-0.719	0.485	4.261	0.972
1200S162-97	0.1017	1.576	5.36	26.966	4.494	4.137	0.331	0.459	26.966	4.327	85.51	8147	7411	26.735	4.091	122.49	8147	7411	5.433	10.331	-0.691	0.470	4.219	0.973
1200S200-54 ¹	0.0566	0.953	3.24	17.662	2.944	4.306	0.393	0.643	16.678	2.425	47.93	1377	1377	16.334	2.073	62.07	1377	1377	1.017	11.550	-1.032	0.681	4.474	0.947
1200S200-68	0.0713	1.192	4.06	21.947	3.658	4.291	0.479	0.634	21.376	3.215	63.54	2771	2771	20.864	2.963	88.71	2771	2771	2.020	14.176	-1.017	0.673	4.455	0.948
1200S200-97	0.1017	1.677	5.71	30.417	5.069	4.258	0.635	0.615	30.417	4.899	96.81	8147	7411	30.175	4.660	139.51	8147	7411	5.783	19.150	-0.987	0.656	4.414	0.950
1200S250-54 ¹	0.																							

Section Properties

Section Properties Table Notes

1. Web depth for track sections is equal to the nominal height plus 2 times design thickness plus the bend radius.
2. Effective properties incorporate the strength increase from the cold work of forming as applicable per the AISI S100-16/S2-20
3. Tabulated gross properties are based on the full, unreduced section away from punchouts.
4. Effective properties of all 'S' sections based on punched sections. Track sections are considered unpunched.
5. For deflection calculations, use the effective moment of inertia.
6. Where effective properties are not listed for a section at 33 or 50 ksi yield, web depth-to-thickness or flange width-to-thickness limits from the AISI are exceeded. Only gross properties are available.

Structural (T) Track Section Properties

Section	Design Thickness (in)	Gross Properties							Effective Properties (33ksi)				Effective 50ksi				Torsional					
		Area (in ²)	Weight (lb/ft)	I _x (in ⁴)	S _x (in ³)	R _x (in)	I _y (in ⁴)	R _y (in)	I _x (in ⁴)	S _x (in ³)	Ma (in-k)	V _{ag} (lb)	I _{xx} (in ⁴)	S _{xx} (in ³)	Ma (in-k)	V _a (lb)	J ^{x1000} (in ⁴)	C _w (in ⁶)	X _o (in)	m (in)	R _o (in)	β
162T125-18	0.0188	0.077	0.26	0.041	0.047	0.733	0.013	0.411	0.030	0.025	0.50	302				0.009	0.007	-0.878	0.503	1.215	0.478	
162T125-27	0.0283	0.117	0.40	0.063	0.072	0.735	0.020	0.410	0.050	0.044	0.87	541				0.031	0.010	-0.872	0.501	1.211	0.482	
162T125-30	0.0312	0.129	0.44	0.070	0.079	0.735	0.022	0.409	0.057	0.050	1.00	597				0.042	0.012	-0.870	0.500	1.210	0.483	
162T125-33	0.0346	0.143	0.49	0.077	0.087	0.736	0.024	0.408	0.066	0.058	1.15	663				0.057	0.013	-0.868	0.499	1.209	0.484	
250T125-18	0.0188	0.094	0.32	0.103	0.079	1.051	0.015	0.400	0.078	0.045	0.90	249				0.011	0.018	-0.769	0.460	1.362	0.681	
250T125-27	0.0283	0.141	0.48	0.157	0.119	1.053	0.022	0.398	0.129	0.079	1.56	685				0.038	0.027	-0.763	0.457	1.360	0.685	
250T125-30	0.0312	0.156	0.53	0.173	0.131	1.053	0.025	0.397	0.145	0.090	1.77	832				0.051	0.030	-0.762	0.456	1.359	0.686	
250T125-33	0.0346	0.173	0.59	0.192	0.145	1.054	0.027	0.397	0.166	0.103	2.03	1024				0.069	0.033	-0.760	0.456	1.358	0.687	
250T125-43	0.0451	0.225	0.77	0.250	0.188	1.055	0.035	0.395	0.231	0.147	2.91	1356				0.153	0.042	-0.755	0.453	1.356	0.690	
250T125-54	0.0566	0.282	0.96	0.318	0.236	1.062	0.043	0.392	0.310	0.203	4.01	1692	0.297	0.188	5.64	2563	0.301	0.054	-0.749	0.449	1.357	0.696
250T125-68	0.0713	0.355	1.21	0.408	0.297	1.072	0.054	0.389	0.408	0.281	5.56	2111	0.402	0.262	7.85	3199	0.602	0.069	-0.740	0.444	1.360	0.704
250T150-27	0.0283	0.156	0.53	0.181	0.137	1.078	0.037	0.486	0.139	0.082	1.61	685				0.042	0.044	-0.976	0.575	1.534	0.595	
250T150-30	0.0312	0.172	0.58	0.199	0.151	1.078	0.040	0.486	0.157	0.093	1.83	832				0.056	0.049	-0.975	0.574	1.533	0.595	
250T150-33	0.0346	0.190	0.65	0.221	0.167	1.079	0.045	0.485	0.179	0.107	2.11	1024				0.076	0.054	-0.973	0.573	1.532	0.596	
250T150-43	0.0451	0.248	0.84	0.289	0.217	1.080	0.058	0.483	0.252	0.154	3.03	1356				0.168	0.070	-0.968	0.570	1.529	0.599	
250T150-54	0.0566	0.311	1.06	0.368	0.273	1.088	0.072	0.481	0.342	0.213	4.22	1692	0.325	0.197	5.89	2563	0.332	0.089	-0.961	0.566	1.529	0.605
250T150-68	0.0713	0.391	1.33	0.472	0.344	1.099	0.089	0.478	0.465	0.299	5.92	2111	0.445	0.276	8.27	3199	0.663	0.114	-0.953	0.561	1.531	0.613
250T200-33	0.0346	0.225	0.76	0.280	0.212	1.117	0.097	0.658	0.203	0.112	2.22	1024				0.090	0.118	-1.418	0.813	1.921	0.455	
250T200-43	0.0451	0.293	1.00	0.366	0.275	1.118	0.126	0.657	0.288	0.163	3.21	1356				0.198	0.153	-1.413	0.810	1.918	0.457	
250T200-54	0.0566	0.367	1.25	0.466	0.346	1.127	0.157	0.654	0.396	0.228	4.51	1692	0.371	0.209	6.25	2563	0.392	0.195	-1.405	0.806	1.917	0.462
250T200-68	0.0713	0.462	1.57	0.600	0.437	1.139	0.196	0.652	0.548	0.324	6.41	2111	0.517	0.296	8.86	3199	0.783	0.251	-1.396	0.800	1.916	0.469
350T125-18	0.0188	0.113	0.38	0.219	0.121	1.394	0.016	0.383	0.174	0.063	1.25	175				0.013	0.038	-0.675	0.418	1.595	0.821	
350T125-27	0.0283	0.170	0.58	0.331	0.182	1.396	0.025	0.381	0.277	0.128	2.53	590				0.045	0.057	-0.670	0.416	1.595	0.823	
350T125-30	0.0312	0.187	0.64	0.365	0.200	1.396	0.027	0.380	0.312	0.145	2.86	790				0.061	0.063	-0.669	0.415	1.594	0.824	
350T125-33	0.0346	0.207	0.71	0.405	0.222	1.397	0.030	0.379	0.354	0.165	3.27	1024				0.083	0.070	-0.668	0.414	1.594	0.824	
350T125-43	0.0451	0.270	0.92	0.528	0.288	1.397	0.038	0.377	0.490	0.233	4.61	1739				0.183	0.090	-0.663	0.412	1.592	0.826	
350T125-54	0.0566	0.339	1.15	0.668	0.361	1.404	0.048	0.375	0.651	0.317	6.26	2392	0.626	0.297	8.89	3372	0.362	0.114	-0.658	0.408	1.595	0.830
350T125-68	0.0713	0.427	1.45	0.851	0.454	1.412	0.059	0.372	0.851	0.433	8.55	2994	0.839	0.407	12.18	4536	0.723	0.144	-0.650	0.403	1.599	0.835
350T150-27	0.0283	0.184	0.63	0.377	0.207	1.431	0.041	0.470	0.298	0.132	2.62	590				0.049	0.094	-0.869	0.529	1.739	0.750	
350T150-30	0.0312	0.203	0.69	0.416	0.228	1.432	0.045	0.469	0.336	0.150	2.96	790				0.066	0.103	-0.867	0.528	1.739	0.751	
350T150-33	0.0346	0.225	0.76	0.461	0.253	1.432	0.049	0.469	0.382	0.171	3.39	1024				0.090	0.114	-0.866	0.527	1.738	0.752	
350T150-43	0.0451	0.293	1.00	0.601	0.328	1.433	0.064	0.467	0.531	0.243	4.80	1739				0.198	0.148	-0.861	0.525	1.736	0.754	
350T150-54	0.0566	0.367	1.25	0.761	0.412	1.440	0.079	0.465	0.712	0.332	6.57	2392	0.679	0.31	9.28	3372	0.392	0.187	-0.855	0.521	1.738	0.758
350T150-68	0.0713	0.462	1.57	0.972	0.518	1.450	0.099	0.462	0.957	0.459	9.07	2994	0.919	0.428	12.81	4536	0.783	0.238	-0.847	0.516	1.741	0.763
350T200-33	0.0346	0.259	0.88	0.574	0.315	1.487	0.108	0.647	0.428	0.181	3.57	1024				0.103	0.249	-1.285	0.761	2.069	0.614	
350T200-43	0.0451	0.338	1.15	0.749	0.409	1.489	0.140	0.645	0.600	0.257	5.09	1739				0.229	0.323	-1.280	0.758	2.066	0.616	
350T200-54	0.0566	0.424	1.44	0.949	0.513	1.496	0.175	0.642	0.814	0.355	7.01	2392	0.77	0.329	9.85	3372	0.453	0.409	-1.273	0.754	2.067	0.621
350T200-68	0.0713	0.534	1.82	1.213	0.647	1.508	0.218	0.639	1.112	0.496	9.80	2994	1.054	0.458	13.71	4536	0.904	0.522	-1.264	0.749	2.069	0.626
362T125-18	0.0188	0.115	0.39	0.237	0.126	1.435	0.017	0.380	0.189	0.065	1.29	169				0.014	0.042	-0.665	0.413	1.627	0.833	
362T125-27	0.0283	0.173	0.59	0.358	0.191	1.438	0.025	0.378	0.301	0.135	2.66	569				0.046	0.062	-0.661	0.411	1.627	0.835	
362T125-30	0.0312	0.191	0.65	0.395	0.210	1.438	0.027	0.378	0.339	0.152	3.01	762				0.062	0.068	-0.659	0.410	1.626	0.836	

¹ Web-height to thickness ratio exceeds 200. Web Stiffeners are required at all support points and concentrated loads.

² Allowable moment includes cold-work of forming.

Section Properties (Continued)

Structural (T) Track Section Properties

Section	Design Thickness (in)	Gross Properties						Effective Properties (33ksi)						Effective 50ksi				Torsional				
		Area (in ²)	Weight (lb/ft)	I _x (in ⁴)	S _x (in ³)	R _x (in)	I _y (in ⁴)	R _y (in)	I _x (in ⁴)	S _x (in ³)	Ma (in-k)	V _{ag} (lb)	I _{xx} (in ⁴)	S _{xx} (in ³)	Ma (in-k)	V _a (lb)	J ^{x1000} (in ⁴)	C _w (in ⁶)	X _o (in)	m (in)	R _o (in)	β
362T125-33	0.0346	0.212	0.72	0.438	0.232	1.438	0.030	0.377	0.384	0.174	3.44	1024					0.085	0.076	-0.658	0.409	1.626	0.836
362T125-43	0.0451	0.276	0.94	0.571	0.302	1.439	0.039	0.375	0.531	0.245	4.84	1739					0.187	0.098	-0.654	0.407	1.625	0.838
362T125-54	0.0566	0.346	1.18	0.723	0.378	1.445	0.048	0.373	0.705	0.332	6.57	2480	0.678	0.312	9.34	3372	0.369	0.123	-0.648	0.404	1.627	0.841
362T125-68	0.0713	0.436	1.48	0.921	0.475	1.454	0.060	0.370	0.921	0.453	8.95	3104	0.907	0.427	12.78	4703	0.738	0.156	-0.641	0.399	1.631	0.846
362T150-27	0.0283	0.187	0.64	0.408	0.217	1.475	0.041	0.468	0.323	0.140	2.76	569					0.050	0.102	-0.857	0.524	1.769	0.765
362T150-30	0.0312	0.207	0.70	0.449	0.239	1.475	0.045	0.467	0.364	0.158	3.12	762					0.067	0.112	-0.856	0.523	1.768	0.766
362T150-33	0.0346	0.229	0.78	0.499	0.264	1.475	0.050	0.467	0.414	0.180	3.56	1024					0.091	0.124	-0.854	0.522	1.767	0.766
362T150-43	0.0451	0.298	1.02	0.650	0.343	1.476	0.064	0.465	0.574	0.255	5.04	1739					0.202	0.160	-0.850	0.519	1.766	0.768
362T150-54	0.0566	0.374	1.27	0.823	0.431	1.483	0.080	0.462	0.769	0.349	6.89	2480	0.735	0.325	9.74	3372	0.400	0.202	-0.844	0.516	1.768	0.772
362T150-68	0.0713	0.471	1.60	1.050	0.542	1.492	0.099	0.459	1.034	0.480	9.49	3104	0.993	0.449	13.43	4703	0.799	0.257	-0.836	0.511	1.771	0.777
362T200-33	0.0346	0.264	0.90	0.619	0.328	1.532	0.110	0.645	0.464	0.190	3.76	1024					0.105	0.269	-1.270	0.754	2.092	0.631
362T200-43	0.0451	0.343	1.17	0.808	0.427	1.534	0.142	0.643	0.649	0.270	5.34	1739					0.233	0.350	-1.265	0.752	2.090	0.633
362T200-54	0.0566	0.431	1.47	1.024	0.536	1.541	0.177	0.640	0.879	0.372	7.35	2480	0.832	0.345	10.34	3372	0.460	0.442	-1.259	0.748	2.091	0.637
362T200-68	0.0713	0.543	1.85	1.307	0.675	1.552	0.221	0.638	1.199	0.519	10.26	3104	1.138	0.48	14.37	4703	0.919	0.564	-1.250	0.743	2.093	0.643
400T125-18 ¹	0.0188	0.122	0.41	0.297	0.144	1.560	0.017	0.374	0.241	0.072	1.42	153					0.014	0.052	-0.637	0.400	1.726	0.864
400T125-27	0.0283	0.184	0.63	0.449	0.217	1.562	0.025	0.372	0.380	0.156	3.08	515					0.049	0.078	-0.633	0.398	1.726	0.866
400T125-30	0.0312	0.203	0.69	0.495	0.239	1.562	0.028	0.371	0.427	0.176	3.49	689					0.066	0.085	-0.632	0.397	1.726	0.866
400T125-33	0.0346	0.225	0.76	0.549	0.265	1.563	0.031	0.371	0.484	0.201	3.97	940					0.090	0.095	-0.630	0.396	1.725	0.867
400T125-43	0.0451	0.293	1.00	0.716	0.344	1.563	0.040	0.369	0.666	0.282	5.57	1739					0.198	0.122	-0.626	0.394	1.724	0.868
400T125-54	0.0566	0.367	1.25	0.904	0.431	1.569	0.049	0.366	0.882	0.381	7.53	2739	0.849	0.359	10.74	3372	0.392	0.154	-0.621	0.390	1.727	0.871
400T125-68	0.0713	0.462	1.57	1.150	0.541	1.577	0.061	0.363	1.150	0.517	10.22	3435	1.134	0.488	14.62	5205	0.783	0.194	-0.614	0.386	1.731	0.874
400T150-27	0.0283	0.198	0.67	0.509	0.246	1.602	0.042	0.461	0.409	0.154	3.04	515					0.053	0.127	-0.824	0.509	1.860	0.804
400T150-30	0.0312	0.218	0.74	0.561	0.271	1.603	0.046	0.461	0.458	0.183	3.61	689					0.071	0.140	-0.823	0.508	1.859	0.804
400T150-33	0.0346	0.242	0.82	0.622	0.300	1.603	0.051	0.460	0.519	0.208	4.12	940					0.097	0.155	-0.821	0.507	1.859	0.805
400T150-43	0.0451	0.315	1.07	0.811	0.390	1.604	0.066	0.458	0.719	0.293	5.80	1739					0.214	0.200	-0.817	0.504	1.857	0.807
400T150-54	0.0566	0.396	1.35	1.025	0.489	1.610	0.082	0.456	0.960	0.399	7.89	2739	0.918	0.374	11.19	3372	0.422	0.252	-0.811	0.501	1.860	0.810
400T150-68	0.0713	0.498	1.69	1.306	0.615	1.619	0.102	0.453	1.286	0.548	10.82	3435	1.237	0.513	15.35	5205	0.844	0.320	-0.804	0.496	1.864	0.814
400T200-33	0.0346	0.277	0.94	0.768	0.371	1.666	0.113	0.639	0.581	0.220	4.34	940					0.110	0.336	-1.229	0.737	2.166	0.678
400T200-43	0.0451	0.360	1.23	1.002	0.482	1.668	0.146	0.637	0.811	0.311	6.14	1739					0.244	0.436	-1.224	0.734	2.164	0.680
400T200-54	0.0566	0.452	1.54	1.268	0.604	1.675	0.182	0.635	1.093	0.426	8.42	2739	1.037	0.397	11.88	3372	0.483	0.551	-1.217	0.730	2.165	0.684
400T200-68	0.0713	0.569	1.94	1.617	0.761	1.685	0.227	0.632	1.485	0.591	11.68	3435	1.412	0.549	16.42	5205	0.965	0.702	-1.209	0.725	2.168	0.689
550T125-27	0.0283	0.226	0.77	0.948	0.336	2.046	0.027	0.348	0.786	0.192	3.79	372					0.060	0.160	-0.543	0.352	2.145	0.936
550T125-30	0.0312	0.250	0.85	1.045	0.370	2.046	0.030	0.347	0.897	0.226	4.47	499					0.081	0.176	-0.542	0.351	2.145	0.936
550T125-33	0.0346	0.277	0.94	1.159	0.410	2.046	0.033	0.346	1.029	0.270	5.33	680					0.110	0.195	-0.541	0.350	2.145	0.936
550T125-43	0.0451	0.360	1.23	1.510	0.533	2.047	0.043	0.344	1.428	0.416	8.23	1504					0.244	0.252	-0.537	0.348	2.144	0.937
550T125-54	0.0566	0.452	1.54	1.903	0.668	2.052	0.053	0.342	1.862	0.597	11.80	2739	1.811	0.535	16.01	2980	0.483	0.315	-0.532	0.345	2.147	0.939
550T125-68	0.0713	0.569	1.94	2.412	0.839	2.058	0.066	0.339	2.412	0.807	15.95	4347	2.379	0.769	23.02	5350	0.965	0.397	-0.526	0.341	2.152	0.940
550T150-27	0.0283	0.241	0.82	1.059	0.376	2.098	0.046	0.436	0.893	0.207	4.10	372					0.064	0.263	-0.716	0.456	2.259	0.900
550T150-30	0.0312	0.265	0.90	1.168	0.414	2.098	0.050	0.435	0.995	0.251	4.96	499					0.086	0.289	-0.715	0.455	2.259	0.900
550T150-33	0.0346	0.294	1.00	1.295	0.459	2.099	0.055	0.434	1.115	0.310	6.12	680					0.117	0.320	-0.714	0.455	2.259	0.900
550T150-43	0.0451	0.383	1.30	1.688	0.596	2.099	0.072	0.432	1.516	0.468	9.25	1504					0.260	0.414	-0.709	0.452	2.258	0.901
550T150-54	0.0566	0.480	1.63	2.128	0.747	2.105	0.089	0.430	2.005	0.628	12.41	2739	1.928	0.595	17.81	2980	0.513	0.519	-0.704	0.449	2.261	0.903
550T150-68	0.0713	0.605	2.06	2.699	0.939	2.112	0.110	0.427	2.660	0.850	16.80	4347	2.569	0.804	24.07	5350	1.025	0.655	-0.698	0.445	2.265	0.905
550T200-33	0.0346	0.329	1.12	1.567	0.555	2.184	0.123	0.613	1.246	0.307	6.06	680					0.131	0.694	-1.088	0.674	2.516	0.813
550T200-43	0.0451	0.428	1.46	2.043	0.722	2.185	0.160	0.611	1.690	0.495	9.79	1504					0.290	0.900	-1.083	0.671	2.514	0.814
550T200-54	0.0566	0.537	1.83	2.578	0.905	2.191	0.199	0.609	2.253	0.669	13.21	2739	2.153	0.63	18.86	2980	0.573	1.133	-1.077	0.668	2.517	0.817
550T200-68	0.0713	0.676	2.30	3.274	1.139	2.200	0.248	0.606	3.027	0.914	18.06	4347	2.894	0.857	25.67	5350	1.146	1.434	-1.070	0.663	2.521	0.820
600T125-27 ¹	0.0283	0.241	0.82	1.168	0.381	2.204	0.028	0.340	0.958	0.210	4.16	341					0.064	0.196	-0.519	0.339	2.290	0.949
600T125-30	0.0312	0.265	0.90	1.288	0.419	2.204	0.031	0.340	1.095	0.249	4.92	456					0.086	0.215	-0.518	0.338	2.289	0.949
600T125-33	0.0346	0.294	1.00	1.428	0.465	2.204	0.034	0.339	1.258	0.297	5.87	622					0.117	0.238	-0.516	0.337	2.289	0.949
600T125-43	0.0451	0.383	1.30	1.861	0.604	2.205	0.044	0.337	1.768	0.461	9.11	1377					0.260	0.307	-0.513	0.335	2.288	0.950
600T125-54	0.0566	0.480	1.63	2.344	0.756	2.209	0.054	0.335	2.299	0.666	13.15	2728	2.241	0.592	17.73	2728	0.513	0.384	-0.508	0.332	2.291	0.951
600T125-68	0.0713	0.605	2.06	2.969	0.950	2.215	0.067	0.332	2.969	0.916	18.09	4347	2.934	0.858	25.69							

Section Properties (Continued)

Structural (T) Track Section Properties

Section	Design Thickness (in)	Gross Properties							Effective Properties (33ksi)				Effective 50ksi				Torsional					
		Area (in ²)	Weight (lb/ft)	I _x (in ⁴)	S _x (in ³)	R _x (in)	I _y (in ⁴)	R _y (in)	I _x (in ⁴)	S _x (in ³)	Ma (in-k)	V _{ag} (lb)	I _{xx} (in ⁴)	S _{xx} (in ³)	Ma (in-k)	V _a (lb)	J ^{x1000} (in ⁴)	C _w (in ⁶)	X _o (in)	m (in)	R _o (in)	β
600T200-54	0.0566	0.565	1.92	3.145	1.015	2.359	0.203	0.600	2.759	0.759	15.00	2728	2.641	0.717	21.48	2728	0.604	1.381	-1.038	0.649	2.646	0.846
600T200-68	0.0713	0.712	2.42	3.990	1.277	2.367	0.254	0.597	3.696	1.034	20.42	4347	3.54	0.973	29.12	5350	1.206	1.746	-1.031	0.644	2.650	0.849
600T200-97	0.1017	1.015	3.45	5.773	1.816	2.385	0.354	0.591	5.758	1.667	32.95	7359	5.558	1.568	46.94	10885	3.499	2.510	-1.016	0.635	2.659	0.854
800T125-33 ¹	0.0346	0.363	1.24	2.895	0.711	2.824	0.036	0.313	2.441	0.407	8.03	465					0.145	0.456	-0.439	0.294	2.875	0.977
800T125-43	0.0451	0.473	1.61	3.773	0.924	2.824	0.046	0.311	3.484	0.640	12.65	1030					0.321	0.589	-0.436	0.292	2.874	0.977
800T125-54	0.0566	0.594	2.02	4.745	1.158	2.827	0.057	0.309	4.668	0.940	18.58	2039	4.426	0.824	24.66	2039	0.634	0.735	-0.432	0.289	2.877	0.977
800T125-68	0.0713	0.748	2.54	5.998	1.454	2.833	0.070	0.306	5.998	1.356	26.80	4087	5.956	1.216	36.39	4087	1.267	0.920	-0.427	0.286	2.881	0.978
800T125-97	0.1017	1.066	3.63	8.613	2.062	2.843	0.096	0.301	8.613	2.062	40.74	8843	8.613	2.062	61.72	10885	3.674	1.296	-0.417	0.279	2.889	0.979
800T150-33 ¹	0.0346	0.380	1.29	3.180	0.781	2.891	0.060	0.397	2.569	0.414	8.18	465					0.152	0.751	-0.588	0.388	2.977	0.961
800T150-43	0.0451	0.496	1.69	4.144	1.015	2.891	0.077	0.395	3.689	0.655	12.95	1030					0.336	0.972	-0.584	0.386	2.976	0.961
800T150-54	0.0566	0.622	2.12	5.214	1.272	2.896	0.096	0.393	4.976	0.969	19.15	2039	4.692	0.844	25.27	2039	0.664	1.215	-0.580	0.383	2.979	0.962
800T150-68	0.0713	0.783	2.67	6.594	1.599	2.902	0.119	0.390	6.527	1.412	27.91	4087	6.361	1.255	37.58	4087	1.327	1.526	-0.575	0.379	2.984	0.963
800T150-97	0.1017	1.116	3.80	9.479	2.269	2.914	0.165	0.384	9.479	2.269	44.83	8843	9.479	2.192	65.62	10885	3.849	2.162	-0.564	0.372	2.993	0.965
800T200-33 ¹	0.0346	0.415	1.41	3.749	0.921	3.005	0.135	0.571	2.788	0.424	8.37	465					0.166	1.638	-0.917	0.589	3.194	0.918
800T200-43	0.0451	0.541	1.84	4.887	1.197	3.006	0.175	0.569	4.043	0.676	13.35	1030					0.367	2.124	-0.913	0.587	3.193	0.918
800T200-54	0.0566	0.679	2.31	6.152	1.501	3.011	0.218	0.567	5.505	1.009	19.93	2039	5.149	0.871	26.09	2039	0.725	2.664	-0.908	0.584	3.196	0.919
800T200-68	0.0713	0.854	2.91	7.786	1.888	3.019	0.272	0.564	7.306	1.490	29.45	4087	7.051	1.31	39.22	4087	1.448	3.357	-0.902	0.580	3.201	0.921
800T200-97	0.1017	1.218	4.15	11.212	2.683	3.034	0.379	0.558	11.176	2.491	49.22	8843	10.833	2.347	70.27	10885	4.200	4.792	-0.889	0.571	3.210	0.923
1000T125-43 ¹	0.0451	0.563	1.92	6.630	1.305	3.431	0.047	0.290	5.886	0.819	16.19	822					0.382	0.973	-0.379	0.259	3.464	0.988
1000T125-54	0.0566	0.707	2.41	8.333	1.634	3.434	0.059	0.288	7.960	1.216	24.03	1628	7.479	1.055	31.59	1628	0.755	1.212	-0.376	0.256	3.466	0.988
1000T125-68	0.0713	0.890	3.03	10.522	2.053	3.438	0.073	0.286	10.452	1.781	35.19	3261	10.155	1.575	47.15	3261	1.508	1.515	-0.372	0.253	3.470	0.989
1000T125-97	0.1017	1.269	4.32	15.077	2.912	3.447	0.100	0.280	15.077	2.907	57.44	8843	15.077	2.753	82.42	9507	4.375	2.123	-0.363	0.247	3.477	0.989
1000T150-43 ¹	0.0451	0.586	1.99	7.207	1.419	3.507	0.080	0.370	6.195	0.837	16.54	822					0.397	1.612	-0.513	0.345	3.564	0.979
1000T150-54	0.0566	0.735	2.50	9.061	1.777	3.511	0.100	0.368	8.430	1.249	24.69	1628	7.88	1.079	32.29	1628	0.785	2.013	-0.509	0.342	3.567	0.980
1000T150-68	0.0713	0.926	3.15	11.445	2.233	3.516	0.124	0.366	11.342	1.846	36.48	3261	10.774	1.621	48.53	3261	1.569	2.522	-0.505	0.339	3.571	0.980
1000T150-97	0.1017	1.320	4.49	16.413	3.170	3.526	0.171	0.360	16.413	3.165	62.54	8843	16.413	2.902	86.9	9507	4.550	3.557	-0.495	0.332	3.579	0.981
1000T200-43 ¹	0.0451	0.631	2.15	8.361	1.646	3.640	0.183	0.539	6.722	0.861	17.01	822					0.428	3.540	-0.813	0.534	3.769	0.953
1000T200-54	0.0566	0.792	2.69	10.516	2.062	3.645	0.228	0.537	9.231	1.295	25.60	1628	8.56	1.111	33.26	1628	0.845	4.434	-0.809	0.531	3.772	0.954
1000T200-68	0.0713	0.997	3.39	13.292	2.594	3.651	0.284	0.534	12.551	1.936	38.26	3261	11.82	1.684	50.42	3261	1.690	5.576	-0.803	0.527	3.776	0.955
1000T200-97	0.1017	1.422	4.84	19.087	3.686	3.664	0.397	0.528	19.031	3.427	67.72	8843	18.583	3.081	92.25	9507	4.901	7.924	-0.791	0.519	3.786	0.956
1200T125-54 ¹	0.0566	0.820	2.79	13.335	2.186	4.033	0.060	0.271	12.296	1.491	29.47	1354	11.46	1.286	38.51	1354	0.876	1.820	-0.333	0.230	4.055	0.993
1200T125-68	0.0713	1.033	3.51	16.826	2.747	4.036	0.074	0.268	16.246	2.206	43.60	2713	15.686	1.934	57.9	2713	1.750	2.270	-0.329	0.227	4.059	0.993
1200T125-97	0.1017	1.472	5.01	24.078	3.897	4.044	0.102	0.263	24.078	3.690	72.92	7902	23.751	3.442	103.06	7902	5.076	3.171	-0.322	0.222	4.065	0.994
1200T150-54 ¹	0.0566	0.848	2.89	14.378	2.357	4.117	0.103	0.348	12.962	1.530	30.23	1354	12.02	1.313	39.31	1354	0.906	3.033	-0.454	0.310	4.156	0.988
1200T150-68	0.0713	1.068	3.64	18.148	2.963	4.121	0.127	0.345	17.568	2.281	45.08	2713	16.566	1.987	59.48	2713	1.810	3.795	-0.450	0.307	4.160	0.988
1200T150-97	0.1017	1.523	5.18	25.987	4.206	4.130	0.176	0.340	25.987	3.996	78.97	7902	25.719	3.616	108.27	7902	5.252	5.335	-0.441	0.301	4.168	0.989
1200T200-54 ¹	0.0566	0.905	3.08	16.464	2.699	4.265	0.236	0.510	14.078	1.582	31.26	1354	12.962	1.35	40.41	1354	0.966	6.714	-0.730	0.487	4.357	0.972
1200T200-68	0.0713	1.140	3.88	20.791	3.395	4.271	0.294	0.508	19.277	2.383	47.09	2713	18.026	2.058	61.62	2713	1.931	8.431	-0.725	0.483	4.362	0.972
1200T200-97	0.1017	1.625	5.53	29.805	4.824	4.283	0.410	0.502	29.805	4.298	84.93	7902	28.959	3.819	114.35	7902	5.602	11.945	-0.714	0.476	4.371	0.973

Allowable Floor and Roof Joist Span Data

Member	Fy (ksi)	Floor and Roof Joist Span Tables																	
		Allowable Uniform Load Table (plf) - Simple Span Joists																	
		Span (ft)																	
		6'-0"	7'-0"	8'-0"	9'-0"	10'-0"	11'-0"	12'-0"	13'-0"	14'-0"	15'-0"	16'-0"	17'-0"	18'-0"	19'-0"	20'-0"	22'-0"	24'-0"	
600S162-33	33	Total Load	168	124	95	75	61	50	42	36	31	27	24	21	19	17	15	13	11
		Live Load	168	124	95	75	61	50	42	36	29	23	19	16	13	11	10	7	6
600S200-33	33		193	142	109	86	70	57	48	41	35	31	27	24	21	19	17	14	12
			193	142	109	86	70	57	48	41	33	27	22	18	15	13	11	8	7
600S162-43	33		252	185	142	112	91	75	63	54	46	40	35	31	28	25	23	19	16
			252	185	142	112	91	75	59	46	37	30	25	21	17	15	13	10	7
600S200-43	33		276	203	155	123	99	82	69	59	51	44	39	34	31	27	25	21	17
			276	203	155	123	99	82	68	53	43	35	29	24	20	17	15	11	8
600S250-43	33		291	214	164	129	105	87	73	62	53	47	41	36	32	29	26	22	18
			291	214	164	129	105	87	73	61	49	40	33	27	23	20	17	13	10
600S162-54	50		426	313	240	189	153	127	107	91	78	68	60	53	47	43	38	32	27
			426	313	240	172	125	94	72	57	46	37	31	25	21	18	16	12	9
600S200-54	50		487	358	274	217	175	145	122	104	90	78	69	61	54	49	44	36	30
			487	358	274	199	145	109	84	66	53	43	35	30	25	21	18	14	10
600S250-54	50		513	377	289	228	185	153	128	109	94	82	72	64	57	51	46	38	32
			513	377	289	226	165	124	95	75	60	49	40	34	28	24	21	15	12
600S162-68	50		612	450	344	272	220	182	153	130	112	98	86	76	68	61	55	46	38
			612	449	301	211	154	116	89	70	56	46	38	31	26	22	19	14	11
600S200-68	50		657	483	370	292	237	195	164	140	121	105	92	82	73	66	59	49	41
			657	483	350	246	179	135	104	82	65	53	44	36	31	26	22	17	13
600S250-68	50		697	512	392	310	251	207	174	148	128	111	98	87	77	69	63	52	44
			697	512	392	283	207	155	120	94	75	61	50	42	35	30	26	19	15
600S162-97	50		1005	738	565	447	362	299	251	214	185	161	141	125	112	100	90	75	63
			971	612	410	288	210	158	121	95	76	62	51	43	36	31	26	20	15
600S200-97	50		1127	828	634	501	406	335	282	240	207	180	158	140	125	112	101	84	70
			1127	715	479	337	245	184	142	112	89	73	60	50	42	36	31	23	18
600S250-97	50		1096	805	616	487	395	326	274	233	201	175	154	137	122	109	99	82	68
			1096	805	555	390	284	213	164	129	104	84	69	58	49	41	36	27	21
600S162-118	50		1207 a	933	714	564	457	378	317	271	233	203	179	158	141	127	114	94	79
			1145 a	721	483	339	247	186	143	113	90	73	60	50	42	36	31	23	18
600S200-118	50		1207 a	1035 a	811	641	519	429	361	307	265	231	203	180	160	144	130	107	90
			1207 a	847 a	567	398	290	218	168	132	106	86	71	59	50	42	36	27	21

General Notes

- All loads are computed in accordance with AISI S100-16, NAS for Design of Cold-Formed Steel Structural Members with Supplement 2.
- Total loads shown are for single span condition and are limited by allowable bending stress or allowable end shear. Live loads shown are limited by allowable bending stress, allowable end shear, or by deflection on 1/360 of span.
- Total load values in table are based on maximum allowable stress only. To limit total load deflection to 1/240 of span, multiply live load value shown by 1.5.
- For two equal continuous spans, the total load shown in these tables will not change. The live load shown may be increased by a factor of 2.4 to maintain the L/360 live load deflection limit, however live load, in any case, cannot exceed the total load shown. Combined bending and shear stresses should be investigated by the designer.
- Joists must be braced against rotation at all supports.
- End web crippling check is based on 3.5 inch end bearing. Joist flanges must be fastened to the support.
- Spans are based on continuous support of compression flange over the full length of the joist.
- End shear and web crippling capacity have not been reduced for punchouts.
- “ a “ indicates that web stiffeners are required at all supports.
- Allowable flexural strength values in the tables are based on the minimum of local, distortional, and lateral-torsional buckling. Distortional buckling strength is based on a $k\phi = 0$. Higher values may be obtained when sheathing is applied to the walls resulting in a higher k-phi value.

LEED Green Building Credits

- MR Credit 2: Construction Waste Management – MBA steel framing is 100% recyclable.
- MR Credit 4: Recycled Content – MBA steel framing is formed from no less than 25.5% post-consumer and 6.8% pre-consumer recycled content.
- MR Credit 5: Regional Materials – MBA has manufacturing facilities in multiple states.

Allowable Floor and Roof Joist Span Data

Member	Fy (ksi)		Floor and Roof Joist Span Tables																
			Allowable Uniform Load Table (plf) - Simple Span Joists																
			Span (ft)																
			6'-0"	7'-0"	8'-0"	9'-0"	10'-0"	11'-0"	12'-0"	13'-0"	14'-0"	15'-0"	16'-0"	17'-0"	18'-0"	19'-0"	20'-0"	22'-0"	24'-0"
600S250-118	50	Total Load	1207	a 1026	785	620	503	415	349	297	256	223	196	174	155	139	126	104	87
		Live Load	1207	a 983	659	463	337	253	195	154	123	100	82	69	58	49	42	32	24
800S162-33	33		126	a 108	a 95	a 84	68	56	47	40	35	30	26	23	21	19	17	14	12
			126	a 108	a 95	a 84	68	56	47	40	35	30	26	23	21	19	17	14	11
800S200-33	33		126	a 108	a 95	a 84	a 76	a 65	54	46	40	35	31	27	24	22	20	16	14
			126	a 108	a 95	a 84	a 76	a 65	54	46	40	35	31	27	24	22	20	16	13
800S162-43	33		326	240	184	145	117	97	82	70	60	52	46	41	36	33	29	24	20
			326	240	184	145	117	97	82	70	60	52	46	40	34	29	25	18	14
800S200-43	33		350	a 277	212	167	136	112	94	80	69	60	53	47	42	38	34	28	24
			350	a 277	212	167	136	112	94	80	69	60	53	47	40	34	29	22	17
800S250-43	33		350	a 291	223	176	143	118	99	84	73	63	56	49	44	40	36	29	25
			350	a 291	223	176	143	118	99	84	73	63	56	49	44	38	33	25	19
800S162-54	50		580	426	326	258	209	173	145	124	107	93	82	72	64	58	52	43	36
			580	426	326	258	209	173	142	112	89	73	60	50	42	36	31	23	18
800S200-54	50		667	490	375	296	240	198	167	142	122	107	94	83	74	67	60	50	42
			667	490	375	296	240	198	166	131	105	85	70	58	49	42	36	27	21
800S250-54	50		697	a 515	394	311	252	208	175	149	129	112	99	87	78	70	63	52	44
			697	a 515	394	311	252	208	175	147	118	96	79	66	55	47	40	30	23

General Notes

- All loads are computed in accordance with AISI S100-16, NAS for Design of Cold-Formed Steel Structural Members with Supplement 2.
- Total loads shown are for single span condition and are limited by allowable bending stress or allowable end shear. Live loads shown are limited by allowable bending stress, allowable end shear, or by deflection on 1/360 of span.
- Total load values in table are based on maximum allowable stress only. To limit total load deflection to 1/240 of span, multiply live load value shown by 1.5.
- For two equal continuous spans, the total load shown in these tables will not change. The live load shown may be increased by a factor of 2.4 to maintain the L/360 live load deflection limit, however live load, in any case, cannot exceed the total load shown. Combined bending and shear stresses should be investigated by the designer.
- Joists must be braced against rotation at all supports.
- End web crippling check is based on 3.5 inch end bearing. Joist flanges must be fastened to the support.
- Spans are based on continuous support of compression flange over the full length of the joist.
- End shear and web crippling capacity have not been reduced for punchouts.
- “ a “ indicates that web stiffeners are required at all supports.
- Allowable flexural strength values in the tables are based on the minimum of local, distortional, and lateral-torsional buckling. Distortional buckling strength is based on a $k\phi = 0$. Higher values may be obtained when sheathing is applied to the walls resulting in a higher k-phi value.

LEED Green Building Credits

- MR Credit 2: Construction Waste Management – MBA steel framing is 100% recyclable.
- MR Credit 4: Recycled Content – MBA steel framing is formed from no less than 25.5% post-consumer and 6.8% pre-consumer recycled content.
- MR Credit 5: Regional Materials – MBA has manufacturing facilities in multiple states.

Allowable Floor and Roof Joist Span Data

Member	Fy (ksi)		Floor and Roof Joist Span Tables																
			Allowable Uniform Load Table (plf) - Simple Span Joists @ 24" o.c. Spacing																
			Span (ft)																
			6'-0"	7'-0"	8'-0"	9'-0"	10'-0"	11'-0"	12'-0"	13'-0"	14'-0"	15'-0"	16'-0"	17'-0"	18'-0"	19'-0"	20'-0"	22'-0"	24'-0"
800S162-68	50	Total Load	794	584	447	353	286	236	199	169	146	127	112	99	88	79	71	59	50
		Live Load	794	584	447	353	286	232	179	141	113	92	75	63	53	45	39	29	22
800S200-68	50		910	668	512	404	328	271	227	194	167	146	128	113	101	91	82	68	57
			910	668	512	404	328	267	206	162	130	105	87	72	61	52	44	33	26
800S250-68	50		960	705	540	427	346	286	240	205	176	154	135	120	107	96	86	71	60
			960	705	540	427	346	286	234	184	147	120	99	82	69	59	51	38	29
800S162-97	50		1385	1017	779	615	498	412	346	295	254	222	195	172	154	138	125	103	87
			1385	1017	779	583	425	319	246	193	155	126	104	86	73	62	53	40	31
800S200-97	50		1589	1168	894	706	572	473	397	339	292	254	224	198	177	159	143	118	99
			1589	1168	894	672	490	368	283	223	178	145	120	100	84	71	61	46	35
800S250-97	50		1537	1129	865	683	553	457	384	327	282	246	216	192	171	153	138	114	96
			1537	1129	865	683	553	420	324	254	204	166	136	114	96	82	70	53	40
800S162-118	50		1868	1372	1051	830	672	556	467	398	343	299	263	233	208	186	168	139	117
			1868	1372	983	690	503	378	291	229	183	149	123	102	86	73	63	47	36
800S200-118	50		2080	1528	1170	925	749	619	520	443	382	333	293	259	231	207	187	155	130
			2080	1528	1137	799	582	437	337	265	212	173	142	119	100	85	73	55	42
800S250-118	50		1982	1456	1115	881	714	590	496	422	364	317	279	247	220	198	178	147	124
			1982	1456	1115	881	666	501	386	303	243	197	163	136	114	97	83	63	48

General Notes

- All loads are computed in accordance with AISI S100-16, NAS for Design of Cold-Formed Steel Structural Members with Supplement 2.
- Total loads shown are for single span condition and are limited by allowable bending stress or allowable end shear. Live loads shown are limited by allowable bending stress, allowable end shear, or by deflection on 1/360 of span.
- Total load values in table are based on maximum allowable stress only. To limit total load deflection to 1/240 of span, multiply live load value shown by 1.5.
- For two equal continuous spans, the total load shown in these tables will not change. The live load shown may be increased by a factor of 2.4 to maintain the L/360 live load deflection limit, however live load, in any case, cannot exceed the total load shown. Combined bending and shear stresses should be investigated by the designer.
- Joists must be braced against rotation at all supports.
- End web crippling check is based on 3.5 inch end bearing. Joist flanges must be fastened to the support.
- Spans are based on continuous support of compression flange over the full length of the joist.
- End shear and web crippling capacity have not been reduced for punchouts.
- " a " indicates that web stiffeners are required at all supports.
- Allowable flexural strength values in the tables are based on the minimum of local, distortional, and lateral-torsional buckling. Distortional buckling strength is based on a $k\phi = 0$. Higher values may be obtained when sheathing is applied to the walls resulting in a higher k-phi value.

LEED Green Building Credits

- MR Credit 2: Construction Waste Management – MBA steel framing is 100% recyclable.
- MR Credit 4: Recycled Content – MBA steel framing is formed from no less than 25.5% post-consumer and 6.8% pre-consumer recycled content.
- MR Credit 5: Regional Materials – MBA has manufacturing facilities in multiple states.

Allowable Floor and Roof Joist Span Data

Member	Fy (ksi)		Floor and Roof Joist Span Tables																
			Allowable Uniform Load Table (plf) - Simple Span Joists @ 24" o.c. Spacing																
			Span (ft)																
			11'-0"	12'-0"	13'-0"	14'-0"	15'-0"	16'-0"	17'-0"	18'-0"	19'-0"	20'-0"	22'-0"	24'-0"	26'-0"	28'-0"	30'-0"	32'-0"	34'-0"
1000S162-431	33	Total Load	100	84	71	62	54	47	42	37	33	30	25	21	18	15	13	12	10
		Live Load	100	84	71	62	54	47	42	37	33	30	25	21	18	15	12	10	8
1000S200-431	33		117	98	84	72	63	55	49	44	39	35	29	25	21	18	16	14	12
			117	98	84	72	63	55	49	44	39	35	29	25	21	17	14	11	10
1000S250-431	33		122 a	104	88	76	66	58	52	46	41	37	31	26	22	19	17	15	13
			122 a	104	88	76	66	58	52	46	41	37	31	26	22	19	17	14	11
1000S162-54	50		213	179	153	132	115	101	89	80	71	64	53	45	38	33	29	25	22
			213	179	153	132	115	100	84	71	60	51	39	30	23	19	15	13	10
1000S200-54	50		248	209	178	153	134	117	104	93	83	75	62	52	44	38	33	29	26
			248	209	178	153	134	115	96	81	69	59	44	34	27	21	17	14	12
1000S250-54	50		263	221	188	162	141	124	110	98	88	79	66	55	47	41	35	31	27
			263	221	188	162	141	124	110	95	81	69	52	40	32	25	21	17	14
1000S162-68	50		296	249	212	183	159	140	124	111	99	90	74	62	53	46	40	35	31
			296	249	212	183	155	128	107	90	76	65	49	38	30	24	19	16	13
1000S200-68	50		342	288	245	211	184	162	143	128	115	104	86	72	61	53	46	40	36
			342	288	245	211	177	146	122	102	87	75	56	43	34	27	22	18	15
1000S250-68	50		363	305	260	224	195	172	152	136	122	110	91	76	65	56	49	43	38
			363	305	260	224	195	168	140	118	100	86	65	50	39	31	25	21	18
1000S162-97	50		483	406	346	298	260	228	202	180	162	146	121	102	86	75	65	57	51
			483	406	338	270	220	181	151	127	108	93	70	54	42	34	27	23	19
1000S200-97	50		554	465	396	342	298	262	232	207	186	167	138	116	99	85	74	65	58
			554	465	385	308	250	206	172	145	123	106	79	61	48	39	31	26	22
1000S250-97	50		590	496	423	364	317	279	247	220	198	179	148	124	106	91	79	70	62
			590	496	423	348	283	233	194	164	139	119	90	69	54	43	35	29	24
1000S162-118	50		664	558	476	410	357	314	278	248	223	201	166	140	119	103	89	78	70
			663	510	401	321	261	215	179	151	129	110	83	64	50	40	33	27	22
1000S200-118	50		759	638	543	469	408	359	318	283	254	230	190	159	136	117	102	90	79
			757	583	459	367	299	246	205	173	147	126	95	73	57	46	37	31	26
1000S250-118	50		769	646	551	475	414	364	322	287	258	233	192	162	138	119	103	91	81
			769	646	519	416	338	278	232	195	166	143	107	82	65	52	42	35	29

General Notes

- All loads are computed in accordance with AISI S100-16, NAS for Design of Cold-Formed Steel Structural Members with Supplement 2.
- Total loads shown are for single span condition and are limited by allowable bending stress or allowable end shear. Live loads shown are limited by allowable bending stress, allowable end shear, or by deflection on 1/360 of span.
- Total load values in table are based on maximum allowable stress only. To limit total load deflection to 1/240 of span, multiply live load value shown by 1.5.
- For two equal continuous spans, the total load shown in these tables will not change. The live load shown may be increased by a factor of 2.4 to maintain the L/360 live load deflection limit, however live load, in any case, cannot exceed the total load shown. Combined bending and shear stresses should be investigated by the designer.
- Joists must be braced against rotation at all supports.
- End web crippling check is based on 3.5 inch end bearing. Joist flanges must be fastened to the support.
- Spans are based on continuous support of compression flange over the full length of the joist.
- End shear and web crippling capacity have not been reduced for punchouts.
- “ a “ indicates that web stiffeners are required at all supports.
- Allowable flexural strength values in the tables are based on the minimum of local, distortional, and lateral-torsional buckling. Distortional buckling strength is based on a $k\phi = 0$. Higher values may be obtained when sheathing is applied to the walls resulting in a higher k-phi value.

LEED Green Building Credits

- MR Credit 2: Construction Waste Management – MBA steel framing is 100% recyclable.
- MR Credit 4: Recycled Content – MBA steel framing is formed from no less than 25.5% post-consumer and 6.8% pre-consumer recycled content.
- MR Credit 5: Regional Materials – MBA has manufacturing facilities in multiple states.

Allowable Floor and Roof Joist Span Data

Member	Fy (ksi)		Floor and Roof Joist Span Tables																
			Allowable Uniform Load Table (plf) - Simple Span Joists @ 24" o.c. Spacing																
			Span (ft)																
			11'-0"	12'-0"	13'-0"	14'-0"	15'-0"	16'-0"	17'-0"	18'-0"	19'-0"	20'-0"	22'-0"	24'-0"	26'-0"	28'-0"	30'-0"	32'-0"	34'-0"
1400S300-54	50	Total Load	171 ^a	157 ^a	145 ^a	134 ^a	125 ^a	118 ^a	111 ^a	105 ^a	99 ^a	94 ^a	78	65	56	48	42	37	33
		Live Load	171 ^a	157 ^a	145 ^a	134 ^a	125 ^a	118 ^a	111 ^a	105 ^a	99 ^a	94 ^a	78	65	56	48	42	36	30
1400S200-68	50		430 ^a	390	332	287	250	219	194	173	156	140	116	98	83	72	62	55	49
			430 ^a	390	332	287	250	219	194	173	156	140	116	94	74	59	48	40	33
1400S250-68	50		430 ^a	394 ^a	359	310	270	237	210	187	168	152	125	105	90	77	67	59	53
			430 ^a	394 ^a	359	310	270	237	210	187	168	152	125	105	84	67	54	45	37
1400S300-68	50		430 ^a	394 ^a	364 ^a	325	283	249	220	196	176	159	131	110	94	81	71	62	55
			430 ^a	394 ^a	364 ^a	325	283	249	220	196	176	159	131	110	91	73	59	49	41
1400S200-97	50		778	654	557	480	419	368	326	291	261	235	195	163	139	120	105	92	81
			778	654	557	480	419	368	326	291	261	235	179	138	109	87	71	58	49
1400S250-97	50		840	706	602	519	452	397	352	314	282	254	210	177	150	130	113	99	88
			840	706	602	519	452	397	352	314	282	254	200	154	121	97	79	65	54
1400S300-97	50		883	742	632	545	475	417	370	330	296	267	221	185	158	136	119	104	92
			883	742	632	545	475	417	370	330	296	267	219	169	133	106	86	71	59
1400S200-111	50		1032	867	739	637	555	488	432	385	346	312	258	217	185	159	139	122	108
			1032	867	739	637	555	488	432	385	341	293	220	169	133	107	87	71	60
1400S250-111	50		1116	938	799	689	600	528	467	417	374	338	279	235	200	172	150	132	117
			1116	938	799	689	600	528	467	417	374	325	244	188	148	119	96	79	66
1400S300-111	50		1175	988	842	726	632	556	492	439	394	356	294	247	210	181	158	139	123
			1175	988	842	726	632	556	492	439	394	356	269	207	163	131	106	87	73
1600S200-68	50		300 ^a	275 ^a	254 ^a	236 ^a	220 ^a	203	180	160	144	130	107	90	77	66	58	51	45
			300 ^a	275 ^a	254 ^a	236 ^a	220 ^a	203	180	160	144	130	107	90	77	66	58	51	45
1600S250-68	50		300 ^a	275 ^a	254 ^a	236 ^a	220 ^a	206 ^a	194 ^a	175	157	142	117	98	84	72	63	55	49
			300 ^a	275 ^a	254 ^a	236 ^a	220 ^a	206 ^a	194 ^a	175	157	142	117	98	84	72	63	55	49
1600S300-68	50		300 ^a	275 ^a	254 ^a	236 ^a	220 ^a	206 ^a	194 ^a	183 ^a	166	150	124	104	88	76	66	58	52
			300 ^a	275 ^a	254 ^a	236 ^a	220 ^a	206 ^a	194 ^a	183 ^a	166	150	124	104	88	76	66	58	52
1600S350-68	50		300 ^a	275 ^a	254 ^a	236 ^a	220 ^a	206 ^a	194 ^a	183 ^a	174 ^a	165 ^a	150 ^a	130	111	96	83	73	65
			300 ^a	275 ^a	254 ^a	236 ^a	220 ^a	206 ^a	194 ^a	183 ^a	174 ^a	165 ^a	150 ^a	130	111	96	83	73	64
1600S200-97	50		874	734	626	539	470	413	366	326	293	264	218	184	156	135	117	103	91
			874	734	626	539	470	413	366	326	293	264	218	184	149	119	97	80	67
1600S250-97	50		951	799	681	587	511	450	398	355	319	288	238	200	170	147	128	112	100
			951	799	681	587	511	450	398	355	319	288	238	200	166	133	108	89	74

General Notes

- All loads are computed in accordance with AISI S100-16, NAS for Design of Cold-Formed Steel Structural Members with Supplement 2.
- Total loads shown are for single span condition and are limited by allowable bending stress or allowable end shear. Live loads shown are limited by allowable bending stress, allowable end shear, or by deflection on 1/360 of span.
- Total load values in table are based on maximum allowable stress only. To limit total load deflection to 1/240 of span, multiply live load value shown by 1.5.
- For two equal continuous spans, the total load shown in these tables will not change. The live load shown may be increased by a factor of 2.4 to maintain the L/360 live load deflection limit, however live load, in any case, cannot exceed the total load shown. Combined bending and shear stresses should be investigated by the designer.
- Joists must be braced against rotation at all supports.
- End web crippling check is based on 3.5 inch end bearing. Joist flanges must be fastened to the support.
- Spans are based on continuous support of compression flange over the full length of the joist.
- End shear and web crippling capacity have not been reduced for punchouts.
- “ a “ indicates that web stiffeners are required at all supports.
- Allowable flexural strength values in the tables are based on the minimum of local, distortional, and lateral-torsional buckling. Distortional buckling strength is based on a $k\phi = 0$. Higher values may be obtained when sheathing is applied to the walls resulting in a higher k-phi value.

LEED Green Building Credits

- MR Credit 2: Construction Waste Management – MBA steel framing is 100% recyclable.
- MR Credit 4: Recycled Content – MBA steel framing is formed from no less than 25.5% post-consumer and 6.8% pre-consumer recycled content.
- MR Credit 5: Regional Materials – MBA has manufacturing facilities in multiple states.

Allowable Floor and Roof Joist Span Data

Member	Fy (ksi)		Floor and Roof Joist Span Tables																
			Allowable Uniform Load Table (plf) - Simple Span Joists																
			Span (ft)																
			6'-0"	7'-0"	8'-0"	9'-0"	10'-0"	11'-0"	12'-0"	13'-0"	14'-0"	15'-0"	16'-0"	17'-0"	18'-0"	19'-0"	20'-0"	22'-0"	24'-0"
600S162-33	33	Total Load	168	124	95	75	61	50	42	36	31	27	24	21	19	17	15	13	11
		Live Load	168	124	95	75	61	50	42	36	29	23	19	16	13	11	10	7	6
600S200-33	33		193	142	109	86	70	57	48	41	35	31	27	24	21	19	17	14	12
			193	142	109	86	70	57	48	41	33	27	22	18	15	13	11	8	7
600S162-43	33		252	185	142	112	91	75	63	54	46	40	35	31	28	25	23	19	16
			252	185	142	112	91	75	59	46	37	30	25	21	17	15	13	10	7
600S200-43	33		276	203	155	123	99	82	69	59	51	44	39	34	31	27	25	21	17
			276	203	155	123	99	82	68	53	43	35	29	24	20	17	15	11	8
600S250-43	33		291	214	164	129	105	87	73	62	53	47	41	36	32	29	26	22	18
			291	214	164	129	105	87	73	61	49	40	33	27	23	20	17	13	10
600S162-54	50		426	313	240	189	153	127	107	91	78	68	60	53	47	43	38	32	27
			426	313	240	172	125	94	72	57	46	37	31	25	21	18	16	12	9

General Notes

1. All loads are computed in accordance with AISI S100-16, NAS for Design of Cold-Formed Steel Structural Members with Supplement 2.
2. Total loads shown are for single span condition and are limited by allowable bending stress or allowable end shear. Live loads shown are limited by allowable bending stress, allowable end shear, or by deflection on 1/360 of span.
3. Total load values in table are based on maximum allowable stress only. To limit total load deflection to 1/240 of span, multiply live load value shown by 1.5.
4. For two equal continuous spans, the total load shown in these tables will not change. The live load shown may be increased by a factor of 2.4 to maintain the L/360 live load deflection limit, however live load, in any case, cannot exceed the total load shown. Combined bending and shear stresses should be investigated by the designer.
5. Joists must be braced against rotation at all supports.
6. End web crippling check is based on 3.5 inch end bearing. Joist flanges must be fastened to the support.
7. Spans are based on continuous support of compression flange over the full length of the joist.
8. End shear and web crippling capacity have not been reduced for punchouts.
9. “ a “ indicates that web stiffeners are required at all supports.
10. Allowable flexural strength values in the tables are based on the minimum of local, distortional, and lateral-torsional buckling. Distortional buckling strength is based on a $k\phi = 0$. Higher values may be obtained when sheathing is applied to the walls resulting in a higher k-phi value.

LEED Green Building Credits

- MR Credit 2: Construction Waste Management – MBA steel framing is 100% recyclable.
- MR Credit 4: Recycled Content – MBA steel framing is formed from no less than 25.5% post-consumer and 6.8% pre-consumer recycled content.
- MR Credit 5: Regional Materials – MBA has manufacturing facilities in multiple states.

Curtain Wall – Table Notes

1. Lateral loads have not been modified for strength checks: full loads are applied.
2. Calculated properties are based on AISI S100-16/52-20, "North American Specification for Cold-Formed Steel Structural Members."
3. For 15 psf or higher wind pressure, read the note below.

IBC 2021/ASCE 7-16: Due to the change in the model building codes, design wind pressures determined using IBC 2021/ASCE 7-16 are strength level loads (LRFD) in comparison to those determined in earlier IBC codes which were service level loads (ASD). The load/span tables that follow are based on service level (ASD) wind loads. Therefore, to properly use the load/span tables in this catalog, multiply the IBC 2021/ASCE 7-16 design wind pressures by 0.6 (Reference section 2.4 ASCE 7-16) prior to entering the load/span tables.

-Example:

- * ASCE 7-16 Calculated Design Wind Pressure = 25 psf (Strength level loads, LRFD)
- * Convert to service level loads (ASD) = 25 psf x 0.6 = 15 psf
- * Use 15 psf as the Pressure Value used in this Table to determine the member span

Any Other Building Code: The load/span tables that follow are based on service level (ASD) wind loads. If the wind load being used meets this criterion, it does not need to be modified prior to using the tables.

4. For 15 psf and higher wind pressures have been multiplied by 0.7 x ASD loads, or 0.42 x Ultimate loads for deflection determination, in accordance with footnote "f" of IBC Table 1604.3. The 5 psf live load has not been reduced for deflection checks.
5. Limiting heights are based on continuous support of each flange over the full length of the stud.
6. Limiting heights are based on steel properties alone (non-composite).
7. Web crippling checks are based on end-one flange loading condition using 1-inch end bearing.
8. End shear and web crippling capacity have not been reduced for punchouts. Punchouts are assumed to be at least 10-inches to centered no less than 12 inches from the end of members, in accordance with AISI 5240-20, Section A5.9.
9. Where limiting heights are followed by "e": web stiffeners are required.

Stud Member	Spacing	Fy (ksi)	5 psf			15 psf			20 psf			25 psf			30 psf			
			L/120	L/240	L/360	L/120	L/240	L/360	L/120	L/240	L/360	L/120	L/240	L/360	L/120	L/240	L/360	L/120
250S137-33	12	33	17'-6"	13'-10"	12'-1"	10'-10"	9'-5"	8'-0"	9'-10"	8'-7"	7'-3"	9'-1"	8'-0"	6'-9"	8'-3"	7'-6"	6'-4"	7'-8"
	16		15'-10"	12'-7"	11'-0"	9'-10"	8'-7"	7'-3"	8'-10"	7'-10"	6'-7"	7'-10"	7'-3"	6'-1"	7'-2"	6'-10"	5'-9"	6'-8"
	24		13'-10"	11'-0"	9'-7"	8'-3"	7'-6"	6'-4"	7'-2"	6'-10"	5'-9"	6'-5"	6'-4"	5'-4"	5'-10"	5'-0"	5'-5"	5'-8"
250S137-43	12	33	19'-0"	15'-1"	13'-2"	11'-9"	10'-3"	8'-8"	10'-8"	9'-4"	7'-10"	9'-11"	8'-8"	7'-4"	9'-4"	8'-2"	6'-11"	8'-10"
	16		17'-3"	13'-8"	11'-11"	10'-8"	9'-4"	7'-10"	9'-9"	8'-6"	7'-2"	9'-0"	7'-10"	6'-8"	8'-5"	7'-5"	6'-3"	7'-10"
	24		15'-1"	11'-11"	10'-5"	9'-4"	8'-2"	6'-11"	8'-5"	7'-5"	6'-3"	7'-6"	6'-11"	5'-10"	6'-10"	6'-6"	5'-6"	6'-4"
250S137-54	12	33	20'-3"	16'-1"	14'-1"	12'-7"	11'-0"	9'-3"	11'-5"	10'-0"	8'-5"	10'-7"	9'-3"	7'-10"	10'-0"	8'-9"	7'-4"	9'-6"
	16		18'-5"	14'-8"	12'-9"	11'-5"	10'-0"	8'-5"	10'-5"	9'-1"	7'-8"	9'-8"	8'-5"	7'-1"	9'-1"	7'-11"	6'-8"	8'-7"
	24		16'-1"	12'-9"	11'-2"	10'-0"	8'-9"	7'-4"	9'-1"	7'-11"	6'-8"	8'-5"	7'-4"	6'-2"	7'-11"	6'-11"	5'-10"	7'-5"
250S137-54	12	50	20'-3"	16'-1"	14'-1"	12'-7"	11'-0"	9'-3"	11'-5"	10'-0"	8'-5"	10'-7"	9'-3"	7'-10"	10'-0"	8'-9"	7'-4"	9'-6"
	16		18'-5"	14'-8"	12'-9"	11'-5"	10'-0"	8'-5"	10'-5"	9'-1"	7'-8"	9'-8"	8'-5"	7'-1"	9'-1"	7'-11"	6'-8"	8'-7"
	24		16'-1"	12'-9"	11'-2"	10'-0"	8'-9"	7'-4"	9'-1"	7'-11"	6'-8"	8'-5"	7'-4"	6'-2"	7'-11"	6'-11"	5'-10"	7'-6"
250S137-68	12	50	19'-8"	15'-7"	13'-8"	12'-2"	10'-8"	9'-0"	11'-1"	9'-8"	8'-2"	10'-3"	9'-0"	7'-7"	9'-8"	8'-5"	7'-1"	9'-2"
	16		17'-2"	13'-8"	11'-11"	10'-8"	9'-4"	7'-10"	9'-8"	8'-5"	7'-1"	9'-0"	7'-10"	6'-7"	8'-5"	7'-5"	6'-3"	8'-0"
	24		18'-4"	14'-7"	12'-9"	11'-4"	9'-11"	8'-5"	10'-4"	9'-0"	7'-7"	9'-7"	8'-5"	7'-1"	8'-10"	7'-11"	6'-8"	8'-3"
250S162-33	12	33	16'-8"	13'-3"	11'-7"	10'-4"	9'-0"	7'-7"	9'-5"	8'-2"	6'-11"	8'-5"	7'-7"	6'-5"	7'-8"	7'-2"	6'-0"	7'-1"
	16		14'-7"	11'-7"	10'-1"	8'-10"	7'-11"	6'-8"	7'-8"	7'-2"	6'-0"	6'-10"	6'-8"	5'-7"	6'-3"	5'-3"	5'-10"	5'-10"
	24		19'-11"	15'-10"	13'-10"	12'-4"	10'-10"	9'-1"	11'-3"	9'-10"	8'-3"	10'-5"	9'-1"	7'-8"	9'-10"	8'-7"	7'-3"	9'-4"
250S162-43	12	33	18'-1"	14'-5"	12'-7"	11'-3"	9'-10"	8'-3"	10'-2"	8'-11"	7'-6"	9'-6"	8'-3"	7'-0"	8'-11"	7'-9"	6'-7"	8'-6"
	16		15'-10"	12'-7"	11'-0"	9'-10"	8'-7"	7'-3"	8'-11"	7'-9"	8'-3"	7'-7"	6'-3"	6'-1"	7'-7"	6'-10"	5'-9"	7'-0"
	24		21'-4"	16'-11"	14'-9"	13'-3"	11'-7"	9'-5"	12'-0"	10'-6"	8'-10"	11'-2"	9'-9"	8'-3"	10'-6"	9'-2"	7'-9"	10'-1"
250S162-54	12	33	19'-5"	15'-5"	13'-5"	12'-0"	10'-6"	8'-10"	10'-11"	9'-6"	10'-2"	8'-10"	7'-6"	9'-6"	8'-4"	7'-0"	9'-0"	9'-0"
	16		16'-11"	13'-5"	11'-9"	10'-6"	9'-2"	7'-9"	9'-6"	8'-4"	7'-0"	8'-10"	7'-9"	6'-6"	8'-4"	7'-3"	6'-2"	7'-11"
	24		22'-9"	18'-1"	15'-10"	14'-1"	12'-4"	10'-5"	12'-10"	11'-2"	9'-5"	11'-11"	10'-5"	8'-9"	11'-2"	9'-9"	8'-3"	10'-8"
250S162-54	12	50	20'-8"	16'-5"	14'-4"	12'-10"	11'-2"	9'-5"	11'-8"	10'-2"	8'-7"	10'-10"	9'-5"	8'-0"	10'-2"	8'-11"	7'-6"	9'-8"
	16		18'-1"	14'-4"	12'-6"	11'-2"	9'-9"	8'-3"	10'-2"	8'-11"	7'-6"	9'-5"	8'-3"	7'-0"	8'-11"	7'-9"	6'-7"	8'-5"
	24		23'-0"	18'-10"	16'-5"	14'-8"	12'-10"	10'-10"	13'-2"	11'-8"	9'-10"	11'-10"	10'-10"	9'-2"	10'-9"	10'-2"	8'-7"	10'-0"
350S162-33	12	33	21'-7"	17'-1"	14'-11"	13'-2"	11'-8"	9'-10"	11'-5"	10'-7"	8'-11"	10'-3"	9'-10"	8'-4"	9'-4"	9'-3"	7'-10"	8'-8"
	16		18'-3"	14'-11"	13'-1"	10'-9"	10'-2"	8'-7"	9'-4"	9'-3"	7'-10"	8'-4"	8'-4"	7'-3"	7'-7"	6'-10"	7'-1"	8'-8"
	24		25'-10"	20'-6"	17'-11"	16'-0"	14'-0"	11'-9"	14'-6"	12'-8"	10'-8"	13'-6"	11'-9"	9'-11"	12'-8"	11'-1"	9'-4"	11'-8"
350S162-43	12	33	23'-5"	18'-7"	16'-3"	14'-6"	12'-8"	10'-8"	13'-2"	11'-6"	9'-9"	12'-0"	10'-8"	9'-0"	10'-11"	10'-1"	8'-6"	10'-2"
	16		20'-6"	16'-3"	14'-2"	12'-8"	11'-1"	9'-4"	10'-11"	10'-1"	8'-6"	9'-9"	9'-4"	7'-11"	8'-11"	8'-10"	7'-5"	8'-3"
	24		27'-8"	21'-11"	19'-2"	17'-2"	15'-0"	12'-7"	15'-7"	13'-7"	11'-6"	14'-5"	12'-7"	10'-8"	13'-7"	11'-11"	10'-0"	12'-11"
350S162-54	12	33	25'-1"	19'-11"	17'-5"	15'-7"	13'-7"	11'-6"	14'-2"	12'-4"	10'-5"	13'-1"	11'-6"	9'-8"	12'-4"	10'-9"	9'-1"	11'-9"
	16		21'-11"	17'-5"	15'-2"	13'-7"	11'-11"	10'-0"	12'-4"	10'-9"	9'-1"	11'-6"	10'-0"	8'-5"	10'-9"	9'-5"	7'-11"	10'-3"
	24		29'-7"	23'-6"	20'-6"	18'-4"	16'-0"	13'-6"	16'-8"	14'-7"	12'-3"	15'-5"	13'-6"	11'-5"	14'-7"	12'-8"	10'-9"	13'-10"
350S162-68	12	50	26'-10"	21'-4"	18'-7"	16'-8"	14'-7"	12'-3"	15'-1"	13'-3"	11'-2"	14'-0"	12'-3"	10'-4"	13'-3"	11'-7"	9'-9"	12'-7"
	16		23'-6"	18'-7"	16'-3"	14'-7"	12'-8"	10'-9"	13'-3"	11'-7"	9'-9"	12'-3"	10'-9"	9'-0"	11'-7"	11'-11"	8'-6"	11'-0"
	24		32'-7"	25'-11"	22'-7"	20'-3"	17'-8"	14'-11"	18'-4"	16'-0"	13'-6"	17'-1"	14'-11"	12'-7"	16'-0"	14'-0"	11'-10"	15'-3"
350S162-97	12	50	29'-8"	23'-6"	20'-7"	18'-4"	16'-0"	13'-6"	16'-8"	14'-7"	12'-4"	15'-6"	13'-6"	11'-5"	14'-7"	12'-9"	10'-9"	13'-10"
	16		25'-11"	20'-7"	17'-11"	16'-0"	14'-0"	11'-10"	14'-7"	12'-9"	10'-9"	13'-6"	11'-10"	10'-0"	12'-9"	11'-1"	9'-5"	12'-1"
	24		27'-3"	21'-8"	18'-11"	16'-11"	14'-9"	12'-5"	15'-4"	13'-5"	11'-4"	14'-3"	12'-5"	10'-6"	13'-5"	11'-9"	9'-11"	12'-6"
350S200-43	12	33	24'-9"	19'-8"	17'-2"	15'-4"	13'-5"	11'-4"	13'-11"	12'-2"	10'-3"	12'-10"	11'-4"	9'-6"	11'-9"	10'-8"	9'-0"	10'-10"
	16		21'-8"	17'-2"	15'-0"	13'-5"	11'-9"	9'-11"	11'-9"	10'-8"	9'-0"	10'-6"	9'-11"	8'-4"	9'-7"	9'-4"	7'-10"	8'-10"
	24		21'-8"	17'-2"	15'-0"	13'-5"	11'-9"	9'-11"	11'-9"	10'-8"	9'-0"	10'-6"	9'-11"	8'-4"	9'-7"	9'-4"	7'-10"	8'-10"

Curtain Wall – Limiting Wall Heights (Continued)

Stud Member	Spacing	Fy (ksi)	5 psf			15 psf			20 psf			25 psf			30 psf			35 psf			40 psf		
			L/120	L/240	L/360	L/120	L/240	L/360	L/120	L/240	L/360	L/120	L/240	L/360	L/120	L/240	L/360	L/120	L/240	L/360	L/120	L/240	L/360
350S200-54	12	33	29'-3"	23'-2"	20'-3"	18'-1"	15'-10"	13'-4"	16'-5"	14'-4"	12'-1"	15'-3"	13'-4"	11'-3"	14'-4"	12'-7"	13'-8"	11'-11"	10'-1"	13'-1"	11'-5"	9'-7"	
	16		26'-6"	21'-1"	18'-5"	16'-5"	14'-4"	12'-1"	14'-11"	13'-1"	11'-0"	13'-10"	12'-1"	10'-3"	13'-1"	11'-5"	9'-7"	12'-5"	10'-10"	9'-2"	11'-10"	10'-4"	8'-9"
	24		23'-2"	18'-5"	16'-1"	14'-4"	12'-7"	10'-7"	13'-1"	11'-5"	9'-7"	12'-1"	10'-7"	8'-11"	11'-4"	10'-0"	8'-5"	10'-6"	9'-6"	8'-0"	9'-10"	9'-1"	7'-8"
350S200-54	12	50	29'-3"	23'-2"	20'-3"	18'-1"	15'-10"	13'-4"	16'-5"	14'-4"	12'-1"	15'-3"	13'-4"	11'-3"	14'-4"	12'-7"	13'-8"	11'-11"	10'-1"	13'-1"	11'-5"	9'-7"	
	16		26'-6"	21'-1"	18'-5"	16'-5"	14'-4"	12'-1"	14'-11"	13'-1"	11'-0"	13'-10"	12'-1"	10'-3"	13'-1"	11'-5"	9'-7"	12'-5"	10'-10"	9'-2"	11'-10"	10'-4"	8'-9"
	24		23'-2"	18'-5"	16'-1"	14'-4"	12'-7"	10'-7"	13'-1"	11'-5"	9'-7"	12'-1"	10'-7"	8'-11"	11'-5"	10'-0"	8'-5"	10'-10"	9'-6"	8'-0"	10'-4"	9'-1"	7'-8"
350S200-68	12	50	31'-3"	24'-10"	21'-8"	19'-5"	16'-11"	14'-3"	17'-7"	15'-5"	13'-0"	16'-4"	14'-3"	12'-1"	15'-5"	11'-4"	14'-7"	12'-9"	10'-9"	14'-0"	12'-3"	10'-4"	
	16		28'-5"	22'-7"	19'-8"	17'-7"	15'-5"	13'-0"	16'-0"	14'-0"	11'-10"	14'-10"	13'-0"	10'-11"	14'-0"	12'-3"	10'-4"	13'-3"	11'-7"	9'-9"	12'-8"	11'-1"	9'-4"
	24		24'-10"	19'-8"	17'-3"	15'-5"	13'-5"	11'-4"	14'-0"	12'-3"	10'-4"	13'-0"	11'-4"	9'-7"	12'-3"	10'-8"	9'-0"	11'-7"	10'-2"	8'-7"	11'-1"	9'-8"	8'-2"
350S200-97	12	50	34'-7"	27'-5"	24'-0"	21'-5"	18'-9"	15'-10"	19'-6"	17'-0"	14'-4"	18'-1"	15'-10"	13'-4"	17'-0"	14'-10"	12'-6"	16'-2"	14'-1"	11'-11"	15'-6"	13'-6"	
	16		31'-5"	24'-11"	21'-9"	19'-6"	17'-0"	14'-4"	17'-8"	15'-6"	13'-0"	16'-5"	14'-4"	12'-1"	15'-6"	13'-6"	11'-5"	14'-8"	12'-10"	10'-10"	14'-1"	12'-3"	10'-4"
	24		27'-5"	21'-9"	19'-0"	17'-0"	14'-10"	12'-6"	15'-6"	13'-6"	11'-5"	14'-4"	12'-6"	10'-7"	13'-6"	11'-10"	9'-11"	12'-10"	11'-2"	9'-5"	12'-3"	10'-9"	9'-0"
362S137-33	12	33	23'-3"	18'-5"	16'-1"	14'-5"	12'-7"	10'-7"	12'-7"	11'-5"	9'-8"	11'-3"	10'-7"	8'-11"	10'-3"	10'-0"	8'-5"	9'-6"	9'-6"	8'-0"	8'-11"	8'-11"	7'-8"
	16		21'-1"	16'-9"	14'-8"	12'-7"	11'-5"	9'-8"	10'-11"	10'-5"	8'-9"	9'-9"	9'-8"	8'-2"	8'-11"	8'-11"	7'-8"	8'-3"	8'-3"	7'-3"	7'-8"	7'-8"	6'-11"
	24		17'-9"	14'-8"	12'-10"	10'-3"	10'-0"	8'-5"	8'-11"	8'-11"	7'-8"	7'-8"	7'-11"	7'-1"	7'-3"	7'-3"	6'-8"	6'-9"	6'-9"	6'-4"	6'-3"	6'-3"	6'-3"
362S137-43	12	33	25'-3"	20'-1"	17'-6"	15'-8"	13'-8"	11'-7"	14'-3"	12'-5"	10'-6"	13'-2"	11'-7"	9'-9"	12'-0"	10'-10"	9'-2"	11'-1"	10'-4"	8'-8"	10'-5"	9'-10"	8'-4"
	16		23'-0"	18'-3"	15'-11"	14'-3"	12'-5"	10'-6"	12'-9"	11'-4"	9'-6"	11'-5"	10'-6"	8'-10"	10'-5"	9'-10"	8'-4"	9'-7"	9'-5"	7'-11"	9'-0"	9'-0"	7'-7"
	24		20'-1"	15'-11"	13'-11"	12'-0"	10'-10"	9'-2"	10'-5"	9'-10"	8'-4"	9'-4"	7'-9"	6'-8"	8'-6"	7'-3"	7'-10"	7'-10"	6'-11"	7'-4"	7'-4"	7'-4"	6'-7"
362S137-54	12	33	27'-1"	21'-6"	18'-9"	16'-9"	14'-8"	12'-4"	15'-3"	13'-4"	11'-3"	14'-2"	12'-4"	10'-5"	13'-4"	11'-8"	9'-10"	12'-8"	11'-1"	9'-4"	12'-1"	10'-7"	8'-11"
	16		24'-7"	19'-6"	17'-1"	15'-3"	13'-4"	11'-3"	13'-10"	12'-1"	10'-2"	12'-10"	11'-3"	9'-6"	12'-1"	10'-7"	8'-11"	11'-3"	10'-0"	8'-6"	10'-6"	9'-7"	8'-1"
	24		21'-6"	17'-1"	14'-11"	13'-4"	11'-8"	9'-10"	12'-1"	10'-7"	8'-11"	11'-3"	9'-10"	8'-3"	9'-3"	7'-9"	9'-2"	8'-9"	7'-5"	8'-7"	8'-7"	8'-5"	7'-1"
362S137-54	12	50	27'-1"	21'-6"	18'-9"	16'-9"	14'-8"	12'-4"	15'-3"	13'-4"	11'-3"	14'-2"	12'-4"	10'-5"	13'-4"	11'-8"	9'-10"	12'-8"	11'-1"	9'-4"	12'-1"	10'-7"	8'-11"
	16		24'-7"	19'-6"	17'-1"	15'-3"	13'-4"	11'-3"	13'-10"	12'-1"	10'-2"	12'-10"	11'-3"	9'-6"	12'-1"	10'-7"	8'-11"	11'-6"	10'-0"	8'-6"	11'-0"	9'-7"	8'-1"
	24		21'-6"	17'-1"	14'-11"	13'-4"	11'-8"	9'-10"	12'-1"	10'-7"	8'-11"	11'-3"	9'-10"	8'-3"	9'-3"	7'-9"	9'-2"	8'-9"	7'-5"	8'-7"	8'-7"	8'-5"	7'-1"
362S137-68	12	50	28'-11"	23'-0"	20'-1"	17'-11"	15'-8"	13'-3"	16'-3"	14'-3"	12'-0"	15'-1"	13'-3"	11'-2"	14'-3"	12'-5"	10'-6"	13'-6"	11'-10"	10'-0"	12'-11"	11'-4"	9'-6"
	16		26'-3"	20'-10"	18'-3"	16'-3"	14'-3"	12'-0"	14'-10"	12'-11"	10'-11"	13'-9"	12'-0"	10'-1"	12'-11"	11'-4"	9'-6"	12'-3"	10'-9"	9'-1"	11'-9"	10'-3"	8'-8"
	24		23'-0"	18'-3"	15'-11"	14'-3"	12'-5"	10'-6"	12'-11"	11'-4"	9'-6"	12'-0"	10'-6"	8'-10"	11'-4"	9'-10"	8'-4"	10'-9"	9'-4"	7'-11"	10'-3"	9'-0"	7'-7"
362S162-33	12	33	24'-4"	19'-4"	16'-11"	15'-1"	13'-2"	11'-1"	13'-6"	12'-0"	10'-1"	12'-1"	11'-1"	9'-5"	11'-0"	10'-6"	8'-10"	10'-2"	9'-11"	8'-5"	9'-6"	9'-6"	8'-0"
	16		22'-2"	17'-7"	15'-4"	13'-6"	12'-0"	10'-1"	11'-8"	10'-11"	9'-2"	10'-5"	10'-1"	8'-6"	9'-6"	8'-0"	9'-6"	8'-0"	7'-7"	8'-10"	7'-7"	8'-3"	8'-3"
	24		19'-0"	15'-4"	13'-5"	11'-0"	10'-6"	8'-10"	9'-6"	9'-6"	8'-0"	8'-6"	8'-6"	7'-5"	7'-9"	7'-9"	7'-0"	7'-2"	7'-2"	6'-8"	6'-9"	6'-9"	6'-4"
362S162-43	12	33	26'-6"	21'-0"	18'-5"	16'-5"	14'-4"	12'-1"	14'-11"	13'-0"	11'-0"	13'-10"	12'-1"	10'-2"	12'-11"	11'-5"	9'-7"	11'-11"	10'-10"	9'-2"	11'-2"	10'-4"	8'-9"
	16		24'-1"	19'-1"	16'-8"	14'-11"	13'-0"	11'-0"	13'-7"	11'-10"	10'-0"	12'-3"	11'-0"	9'-3"	11'-2"	10'-4"	8'-9"	10'-4"	9'-10"	8'-3"	9'-8"	9'-5"	7'-11"
	24		21'-0"	16'-8"	14'-7"	12'-11"	11'-5"	9'-7"	11'-2"	10'-4"	8'-9"	10'-0"	9'-7"	8'-1"	9'-2"	9'-0"	7'-7"	8'-5"	8'-5"	7'-3"	7'-11"	7'-11"	6'-11"
350S162-54	12	33	27'-8"	21'-11"	19'-2"	17'-2"	15'-0"	12'-7"	15'-7"	13'-7"	11'-6"	14'-5"	12'-7"	10'-8"	13'-7"	11'-11"	10'-0"	12'-11"	11'-3"	9'-6"	12'-4"	10'-9"	9'-1"
	16		25'-1"	19'-11"	17'-5"	15'-7"	13'-7"	11'-6"	14'-2"	12'-4"	10'-5"	13'-1"	11'-6"	9'-8"	12'-4"	10'-9"	9'-1"	11'-9"	10'-3"	8'-8"	11'-2"	9'-10"	8'-3"
	24		21'-11"	17'-5"	15'-2"	13'-7"	11'-11"	10'-0"	12'-4"	10'-9"	9'-1"	11'-6"	10'-0"	8'-5"	10'-7"	9'-5"	7'-11"	9'-9"	8'-11"	7'-7"	9'-2"	8'-7"	7'-3"
350S162-54	12	50	27'-8"	21'-11"	19'-2"	17'-2"	15'-0"	12'-7"	15'-7"	13'-7"	11'-6"	14'-5"	12'-7"	10'-8"	13'-7"	11'-11"	10'-0"	12'-11"	11'-3"	9'-6"	12'-4"	10'-9"	9'-1"
	16		25'-1"	19'-11"	17'-5"	15'-7"	13'-7"	11'-6"	14'-2"	12'-4"	10'-5"	13'-1"	11'-6"	9'-8"	12'-4"	10'-9"	9'-1"	11'-9"	10'-3"	8'-8"	11'-2"	9'-10"	8'-3"
	24		21'-11"	17'-5"	15'-2"	13'-7"	11'-11"	10'-0"	12'-4"	10'-9"	9'-1"	11'-6"	10'-0"	8'-5"	10'-7"	9'-5"	7'-11"	9'-9"	8'-11"	7'-7"	9'-2"	8'-7"	7'-3"
350S162-68	12	50	27'-8"	21'-11"	19'-2"	17'-2"	15'-0"	12'-7"	15'-7"	13'-7"	11'-6"	14'-5"	12'-7"	10'-8"	13'-7"	11'-11"	10'-0"	12'-11"	11'-3"	9'-6"	12'-4"	10'-9"	9'-1"
	16		25'-1"	19'-11"	17'-5"	15'-7"	13'-7"	11'-6"	14'-2"	12'-4"	10'-5"	13'-1"	11'-6"	9'-8"	12'-4"	10'-9"	9'-1"	11'-9"	10'-3"	8'-8"	11'-2"	9'-10"	8'-3"
	24		21'-11"	17'-5"	15'-2"	13'-7"	11'-11"	10'-0"	12'-4"	10'-9"	9'-1"	11'-6"	10'-0"	8'-5"	10'-7"	9'-5"	7'-11"	9'-9"	8'-11"	7'-7"	9'-2"	8'-7"	7'-3"
350S162-97	12	50	29'-7"	23'-6"	20'-6"	18'-4"	16'-0"	13'-6"	16'-8"	14'-7"	12'-3"	15'-5"	13'-6"	11'-5"	14'-7"	12'-8"	10'-9"	13'-10"	12'-1"	10'-2"	13'-3"	11'-7"	9'-9"
	16		26'-10"	21'-4"	18'-7"	16'-8"	14'-7"	12'-3"	15'-1"	13'-3"	11'-2"	14'-0"	12'-3"	10'-4"	13'-3"	11'-7"	9'-9"	12'-7"	11'-0"	9'-3"	12'-0"	10'-6"	8'-10"
	24		23'-6"	18'-7"	16'-3"	14'-7"	12'-8"	10'-9"	13'-3"	11'-7"	9'-9"	12'-3"	10'-9"	8'-5"	11'-7"	10'-1"	11'-7"	11'-0"	10'-6"	9'-2"	10'-6"	9'-2"	7'-9"
350S200-43	12	33	32'-7"	25'-11"	22'-7"	20'-3"	17'-8"	14'-11"	18'-4"	16'-0"	13'-6"	17'-1"	14'-11"	12'-7"	16'-0"	14'-0"	11'-10"	15'-3"	13'-4"	11'-3"	14'-7"	12'-9"	10'-9"
	16		29'-8"	23'-6"	20'-7"	18'-4"	16'-0"	13'-6"	16'-8"	14'-7"	12'-4"	15'-6"	13'-6"	11'-5"	14'-7"	12'-9"	10'-9"	13'-10"	12'-1"	10'-2"	13'-3"	11'-7"	9'-9"
	24		25'-11"	20'-7"	17'-11"	16'-0"	14'-0"	11'-10"	14'-7"	12'-9"	10'-9"	13'-6"	11'-10"	10'-0"	12'-9"	11'-1"	9'-5"	12'-1"	10'-7"	8'-11"	11'-7"	10'-1"	8'-6"
350S200-54	12	33	27'-3"	21'-8"	18'-11"	16'-11"	14'-9"	12'-5"	15'-4"	13'-5"	11'-4"	14'-3"	12'-5"	10'-6"	13'-5"	11'-9"	9'-11"	12'-6"	11'-1"	9'-5"	11'-9"	10'-8"	9'-0"
	16		24'-9"	19'-8"	17'-2"	15'-4"	13'-5"	11'-4"	13'-11"	12'-2"	10'-3"	12'-10"	11'-4"	9'-6"	11'-9"	10'-8"	9'-0"	10'-10"	10'-1"	8'-6"	10'-2"	9'-8"	8'-2"
	24		21'-8"	17'-2"	15'-0"	13'-5"	11'-9"	9'-11"	11'-9"	10'-8"	9'-0"	10'-6"	9'-11"	8'-4"	9'-7"	9'-4"	7'-10"	8'-10"	8'-10"	7'-5"	8'-4"	8'-4"	7'-1"
350S200-54	12	50	2																				

Curtain Wall – Limiting Wall Heights (Continued)

Stud Member	Spacing	Fy (ksi)	5 psf			15 psf			20 psf			25 psf			30 psf			35 psf			40 psf		
			L/120	L/240	L/360	L/120	L/240	L/360	L/120	L/240	L/360	L/120	L/240	L/360	L/120	L/240	L/360	L/120	L/240	L/360	L/120	L/240	L/360
362S137-33	12	33	23'-3"	18'-5"	16'-1"	14'-5"	12'-7"	10'-7"	12'-7"	11'-5"	9'-8"	11'-3"	10'-7"	8'-11"	10'-3"	10'-0"	8'-5"	9'-6"	9'-6"	8'-0"	8'-11"	8'-11"	7'-8"
	16		21'-1"	16'-9"	14'-8"	12'-7"	11'-5"	9'-8"	10'-11"	10'-5"	8'-9"	9'-9"	9'-8"	8'-2"	8'-11"	8'-11"	7'-8"	8'-3"	8'-3"	6'-9"	7'-3"	7'-8"	6'-11"
	24		17'-9"	14'-8"	12'-10"	10'-3"	10'-0"	8'-5"	8'-11"	8'-11"	7'-8"	7'-11"	7'-11"	7'-1"	7'-3"	7'-3"	6'-8"	6'-9"	6'-9"	6'-4"	6'-3"	6'-3"	6'-1"
362S137-43	12	33	25'-3"	20'-1"	17'-6"	15'-8"	13'-8"	11'-7"	14'-3"	12'-5"	10'-6"	13'-2"	11'-7"	9'-9"	12'-0"	10'-10"	9'-2"	11'-1"	10'-4"	8'-8"	10'-5"	9'-10"	8'-8"
	16		23'-0"	18'-3"	15'-11"	14'-3"	12'-5"	10'-6"	12'-9"	11'-4"	9'-6"	11'-5"	10'-6"	8'-10"	10'-5"	9'-10"	8'-4"	9'-7"	9'-5"	7'-11"	9'-0"	9'-0"	7'-7"
	24		20'-1"	15'-11"	13'-11"	12'-0"	10'-10"	9'-2"	10'-5"	9'-10"	8'-4"	9'-4"	9'-2"	7'-9"	8'-6"	8'-6"	7'-3"	7'-10"	7'-10"	6'-11"	7'-4"	7'-4"	6'-7"
362S137-54	12	33	27'-1"	21'-6"	18'-9"	16'-9"	14'-8"	12'-4"	15'-3"	13'-4"	11'-3"	14'-2"	12'-4"	10'-5"	13'-4"	11'-8"	9'-10"	12'-8"	11'-1"	9'-4"	12'-1"	10'-7"	8'-11"
	16		24'-7"	19'-6"	17'-1"	15'-3"	13'-4"	11'-3"	13'-10"	12'-1"	10'-2"	12'-10"	11'-3"	9'-6"	12'-1"	10'-7"	8'-11"	11'-3"	10'-0"	8'-6"	10'-6"	9'-7"	8'-1"
	24		21'-6"	17'-1"	14'-11"	13'-4"	11'-8"	9'-10"	12'-1"	10'-7"	8'-11"	10'-10"	9'-10"	8'-3"	9'-11"	9'-3"	7'-9"	9'-2"	8'-9"	7'-5"	8'-7"	8'-5"	7'-1"
362S137-54	12	50	27'-1"	21'-6"	18'-9"	16'-9"	14'-8"	12'-4"	15'-3"	13'-4"	11'-3"	14'-2"	12'-4"	10'-5"	13'-4"	11'-8"	9'-10"	12'-8"	11'-1"	9'-4"	12'-1"	10'-7"	8'-11"
	16		24'-7"	19'-6"	17'-1"	15'-3"	13'-4"	11'-3"	13'-10"	12'-1"	10'-2"	12'-10"	11'-3"	9'-6"	12'-1"	10'-7"	8'-11"	11'-6"	10'-0"	8'-6"	11'-0"	9'-7"	8'-1"
	24		21'-6"	17'-1"	14'-11"	13'-4"	11'-8"	9'-10"	12'-1"	10'-7"	8'-11"	11'-3"	9'-10"	8'-3"	10'-7"	9'-3"	7'-9"	10'-0"	8'-9"	7'-5"	9'-7"	8'-5"	7'-1"
362S137-68	12	50	28'-11"	23'-0"	20'-1"	17'-11"	15'-8"	13'-3"	16'-3"	14'-3"	12'-0"	15'-1"	13'-3"	11'-2"	14'-3"	12'-5"	10'-6"	13'-6"	11'-10"	10'-0"	12'-11"	11'-4"	9'-6"
	16		26'-3"	20'-10"	18'-3"	16'-3"	14'-3"	12'-0"	14'-10"	12'-11"	10'-11"	13'-9"	12'-0"	10'-1"	12'-11"	11'-4"	9'-6"	12'-3"	10'-9"	9'-1"	11'-9"	10'-3"	8'-8"
	24		23'-0"	18'-3"	15'-11"	14'-3"	12'-5"	10'-6"	12'-11"	11'-4"	9'-6"	12'-0"	10'-6"	8'-10"	11'-4"	9'-10"	8'-4"	10'-9"	9'-4"	7'-11"	10'-3"	9'-0"	7'-7"
362S162-33	12	33	24'-4"	19'-4"	16'-11"	15'-1"	13'-2"	11'-1"	13'-6"	12'-0"	10'-1"	12'-1"	11'-1"	9'-5"	11'-0"	10'-6"	8'-10"	10'-2"	9'-11"	8'-5"	9'-6"	9'-6"	8'-0"
	16		22'-2"	17'-7"	15'-4"	13'-6"	12'-0"	10'-1"	11'-8"	10'-11"	9'-2"	10'-5"	10'-1"	8'-6"	9'-6"	9'-6"	8'-0"	8'-10"	8'-10"	7'-7"	8'-3"	8'-3"	7'-3"
	24		19'-0"	15'-4"	13'-5"	11'-0"	10'-6"	8'-10"	9'-6"	9'-6"	8'-0"	8'-6"	8'-6"	7'-5"	7'-9"	7'-9"	7'-0"	7'-2"	7'-2"	6'-8"	6'-9"	6'-9"	6'-4"
362S162-43	12	33	26'-6"	21'-0"	18'-5"	16'-5"	14'-4"	12'-1"	14'-11"	13'-0"	11'-0"	13'-10"	12'-1"	10'-2"	12'-11"	11'-5"	9'-7"	11'-11"	10'-10"	9'-2"	11'-2"	10'-4"	8'-9"
	16		24'-1"	19'-1"	16'-8"	14'-11"	13'-0"	11'-0"	13'-7"	11'-10"	10'-0"	12'-3"	11'-0"	9'-3"	11'-2"	10'-4"	8'-9"	10'-4"	9'-10"	8'-3"	9'-8"	9'-5"	7'-11"
	24		21'-0"	16'-8"	14'-7"	12'-11"	11'-5"	9'-7"	11'-2"	10'-4"	8'-9"	10'-0"	9'-7"	8'-1"	9'-2"	9'-0"	7'-7"	8'-5"	8'-5"	7'-3"	7'-11"	7'-11"	6'-11"
362S162-54	12	33	28'-5"	22'-6"	19'-8"	17'-7"	15'-4"	13'-0"	16'-0"	14'-0"	11'-9"	14'-10"	13'-0"	10'-11"	14'-0"	12'-2"	10'-4"	13'-3"	11'-7"	9'-9"	12'-8"	11'-1"	9'-4"
	16		25'-10"	20'-6"	17'-11"	16'-0"	14'-0"	11'-9"	14'-6"	12'-8"	10'-8"	13'-6"	11'-9"	9'-11"	12'-8"	11'-1"	9'-4"	12'-1"	10'-6"	8'-11"	11'-4"	10'-1"	8'-6"
	24		22'-6"	17'-11"	15'-8"	14'-0"	12'-2"	10'-4"	12'-8"	11'-1"	9'-4"	11'-9"	10'-4"	8'-8"	11'-1"	9'-8"	8'-2"	9'-11"	9'-2"	7'-9"	9'-3"	8'-10"	7'-5"
362S162-54	12	50	28'-5"	22'-6"	19'-8"	17'-7"	15'-4"	13'-0"	16'-0"	14'-0"	11'-9"	14'-10"	13'-0"	10'-11"	14'-0"	12'-2"	10'-4"	13'-3"	11'-7"	9'-9"	12'-8"	11'-1"	9'-4"
	16		25'-10"	20'-6"	17'-11"	16'-0"	14'-0"	11'-9"	14'-6"	12'-8"	10'-8"	13'-6"	11'-9"	9'-11"	12'-8"	11'-1"	9'-4"	12'-1"	10'-6"	8'-11"	11'-6"	10'-1"	8'-6"
	24		22'-6"	17'-11"	15'-8"	14'-0"	12'-2"	10'-4"	12'-8"	11'-1"	9'-4"	11'-9"	10'-4"	8'-8"	11'-1"	9'-8"	8'-2"	10'-6"	9'-2"	7'-9"	10'-1"	8'-10"	7'-5"
362S162-68	12	50	30'-5"	24'-1"	21'-1"	18'-10"	16'-5"	13'-10"	17'-1"	14'-11"	12'-7"	15'-11"	13'-10"	11'-8"	14'-11"	13'-1"	11'-0"	14'-2"	12'-5"	10'-6"	13'-7"	11'-10"	10'-0"
	16		27'-7"	21'-11"	19'-2"	17'-1"	14'-11"	12'-7"	15'-7"	13'-7"	11'-5"	14'-5"	12'-7"	10'-8"	13'-7"	11'-10"	10'-0"	12'-11"	11'-3"	9'-6"	12'-4"	10'-9"	9'-1"
	24		24'-1"	19'-2"	16'-9"	14'-11"	13'-1"	11'-0"	13'-7"	11'-10"	10'-0"	12'-7"	11'-0"	9'-3"	11'-10"	10'-4"	8'-9"	11'-3"	9'-10"	8'-4"	10'-9"	9'-5"	7'-11"
362S162-97	12	50	33'-6"	26'-7"	23'-3"	20'-9"	18'-2"	15'-4"	18'-11"	16'-6"	13'-11"	17'-6"	15'-4"	12'-11"	16'-6"	14'-5"	12'-2"	15'-8"	13'-8"	11'-7"	15'-0"	13'-1"	11'-0"
	16		30'-5"	24'-2"	21'-1"	18'-11"	16'-6"	13'-11"	17'-2"	15'-0"	12'-8"	15'-11"	13'-11"	11'-9"	15'-0"	13'-1"	11'-0"	14'-3"	12'-5"	10'-6"	13'-7"	11'-11"	10'-0"
	24		26'-7"	21'-1"	18'-5"	16'-6"	14'-5"	12'-2"	15'-0"	13'-1"	11'-0"	13'-11"	12'-2"	10'-3"	13'-1"	11'-5"	9'-8"	12'-5"	10'-10"	9'-2"	11'-11"	10'-5"	8'-9"
362S200-33	12	33	25'-8"	20'-5"	17'-10"	15'-11"	13'-11"	11'-9"	14'-1"	12'-8"	10'-8"	12'-7"	11'-9"	9'-11"	11'-6"	11'-0"	9'-4"	10'-8"	10'-6"	8'-10"	10'-0"	10'-0"	8'-6"
	16		23'-4"	18'-6"	16'-2"	14'-1"	12'-8"	10'-8"	12'-2"	11'-6"	9'-8"	10'-11"	10'-8"	9'-0"	10'-0"	9'-0"	8'-6"	9'-3"	9'-3"	8'-0"	8'-8"	8'-8"	7'-8"
	24		19'-11"	16'-2"	14'-2"	11'-6"	11'-0"	9'-4"	10'-0"	10'-0"	8'-6"	8'-11"	8'-11"	7'-10"	8'-2"	8'-2"	7'-5"	7'-6"	7'-6"	7'-1"	7'-1"	6'-9"	6'-9"
362S200-43	12	33	28'-0"	22'-3"	19'-5"	17'-4"	15'-2"	12'-9"	15'-9"	13'-9"	11'-7"	14'-8"	12'-9"	10'-9"	13'-9"	12'-0"	10'-2"	12'-10"	11'-5"	9'-8"	12'-0"	10'-11"	9'-3"
	16		25'-5"	20'-2"	17'-8"	15'-9"	13'-9"	11'-7"	14'-4"	12'-6"	10'-7"	13'-2"	11'-7"	9'-10"	12'-0"	10'-11"	9'-3"	11'-1"	10'-5"	8'-9"	10'-5"	9'-11"	8'-4"
	24		22'-3"	17'-8"	15'-5"	13'-9"	12'-0"	10'-2"	12'-0"	10'-11"	9'-3"	10'-9"	10'-2"	8'-7"	9'-9"	9'-7"	8'-1"	9'-1"	9'-1"	7'-8"	8'-6"	8'-6"	7'-4"
362S200-54	12	33	30'-0"	23'-10"	20'-10"	18'-7"	16'-3"	13'-8"	16'-11"	14'-9"	12'-5"	15'-8"	13'-8"	11'-7"	14'-9"	12'-11"	10'-11"	14'-0"	12'-3"	10'-4"	13'-5"	11'-9"	9'-11"
	16		27'-3"	21'-8"	18'-11"	16'-11"	14'-9"	12'-5"	15'-4"	13'-5"	11'-4"	14'-3"	12'-5"	10'-6"	13'-5"	11'-9"	9'-11"	12'-9"	11'-2"	9'-5"	12'-2"	10'-8"	9'-0"
	24		23'-10"	18'-11"	16'-6"	14'-9"	12'-11"	10'-11"	13'-5"	11'-9"	9'-11"	12'-5"	10'-11"	9'-2"	11'-7"	10'-3"	8'-8"	10'-9"	9'-9"	8'-2"	10'-1"	9'-4"	7'-10"
362S200-54	12	50	30'-0"	23'-10"	20'-10"	18'-7"	16'-3"	13'-8"	16'-11"	14'-9"	12'-5"	15'-8"	13'-8"	11'-7"	14'-9"	12'-11"	10'-11"	14'-0"	12'-3"	10'-4"	13'-5"	11'-9"	9'-11"
	16		27'-3"	21'-8"	18'-11"	16'-11"	14'-9"	12'-5"	15'-4"	13'-5"	11'-4"	14'-3"	12'-5"	10'-6"	13'-5"	11'-9"	9'-11"	12'-9"	11'-2"	9'-5"	12'-2"	10'-8"	9'-0"
	24		23'-10"	18'-11"	16'-6"	14'-9"	12'-11"	10'-11"	13'-5"	11'-9"	9'-11"	12'-5"	10'-11"	9'-2"	11'-9"	10'-3"	8'-8"	11'-2"	9'-9"	8'-2"	10'-8"	9'-4"	7'-10"
362S200-68	12	50	32'-2"	25'-6"	22'-3"	19'-11"	17'-5"	14'-8"	18'-1"	15'-10"	13'-4"	16'-10"	14'-8"	12'-5"	15'-10"	13'-10"	11'-8"	15'-0"	13'-1"	11'-1"	14'-4"	12'-7"	10'-7"
	16		29'-2"	23'-2"	20'-3"	18'-1"	15'-10"	13'-4"	16'-5"	14'-4"	12'-1"	15'-3"	13'-4"	11'-3"	14'-4"	12'-7"	10'-7"	13'-8"	11'-11"	10'-1"	13'-1"	11'-5"	9'-7"
	24		25'-6"	20'-3"	17'-8"	15'-10"	13'-10"	11'-8"	14'-4"	12'-7"	10'-7"	13'-4"	11'-8"	9'-10"	12'-7"	11'-0"	9'-3"	11'-11"	10'-5"	8'-9"	11'-5"	10'-0"	8'-5"
362S200-97	12	50	35'-7"	28'-3"	24'-8"	22'-0"	19'-3"	16'-3"	20'-0"	17'-6"	14'-9"	18'-7"	16'-3"	13'-8"	17'-6"	15'-3"	12'-11"	16'-7"	14'-6"	12'-3"	15'-11"	13'-11"	11'-8"
	16		32'-4"	25'-8"	22'-5"	20'-0"	17'-6"	14'-9"	18'-2"	15'-11"	13'-5"	16'-11"	14'-9"	12'-5"	15'-11"	13'-11"	11'-8"	15'-1"	13'-2"	11'-1"	14'-5"	12'-7"	10'-8"
	24		28'-3"	22'-5"	19'-7"	17'-6"	15'-3"	12'-11"	15'-11"	13'-11"	11'-8"	14'-9"	12'-11"	10'-10"	13'-11"	12'-2"	10'-3"	13'-2"	11'-6"	9'-9"	12'-7"	11'-0"	9'-4"
362S250-43	12	33	29'-6"	23'-5"	20'-6"	18'-4"	16'-0"	13'-6"	16'-7"	14'-6"	12'-3"	15'-5"	13'-6"	11'-4"	14'-2"	12'-8"	10'-8"	13'-2"	12'-1"	10'-2"	12'-4"	11'-6"	9'-9"
	16		26'-10"	21'-3"	18'-7"	16'-7"	14'-6"	12'-3"	15'-1"	13'-2"	11'-2"	13'-6"	12'-3"	10'-4"	12'-4"	11'-6"	9'-9"	11'-5"	10'-11"	9'-3"	10'-8"	10'-6"	8'-10"
	24		23'-5"	18'-7"	16'-3"	14'-2"	12'-8"	10'-8"	12'-4"	11'-6"	9'-9"	11'-0"	10'-8"	9'-0"	10'-0"	10'-0"	8'-6"	9'-4"	8'-1"	8'-8"	8'-8"	7'-9"	7'-9"
362S250-54	12	33	31'-8"	25'-2"	21'-11"	19'-7"	17'-2"	14'-6"	17'-10"	15'-7"	13'-2"	16'-7"	14'-6"	12'-2"	15'-7"	13'-7"	11'-6"	14'-10"	12'-11"	10'-11"	13'-11"	12'-4"	10'-5"
	16		28'-9"	22'-10"	19'-11"	17'-10"	15'-7"	13'-2"	16'-2"	14'-2"	11'-11"	15'-0"	13'-2"	1									

Curtain Wall – Limiting Wall Heights (Continued)

Stud Member	Spacing	Fy (ksi)	5 psf			15 psf			20 psf			25 psf			30 psf			35 psf			40 psf		
			L/120	L/240	L/360	L/120	L/240	L/360	L/120	L/240	L/360	L/120	L/240	L/360	L/120	L/240	L/360	L/120	L/240	L/360	L/120	L/240	L/360
362S250-68	12	50	33'-11"	26'-11"	23'-6"	21'-0"	18'-5"	15'-6"	19'-1"	16'-8"	14'-1"	17'-9"	15'-6"	13'-1"	16'-8"	14'-7"	12'-4"	15'-10"	13'-10"	11'-8"	15'-2"	13'-3"	11'-2"
	16		30'-10"	24'-6"	21'-5"	19'-1"	16'-8"	14'-1"	17'-4"	15'-2"	12'-10"	16'-1"	14'-1"	11'-11"	15'-2"	13'-3"	11'-2"	14'-5"	12'-7"	10'-7"	13'-9"	12'-0"	10'-2"
	24		26'-11"	21'-5"	18'-8"	16'-8"	14'-7"	12'-4"	15'-2"	13'-3"	11'-2"	14'-1"	12'-4"	10'-5"	13'-3"	11'-7"	9'-9"	12'-7"	11'-0"	9'-3"	12'-0"	10'-6"	8'-10"
362S250-97	12	50	37'-7"	29'-10"	26'-1"	23'-4"	20'-4"	17'-2"	21'-2"	18'-6"	15'-7"	19'-8"	17'-2"	14'-6"	18'-6"	16'-2"	13'-8"	17'-7"	15'-4"	12'-11"	16'-10"	14'-8"	12'-5"
	16		34'-2"	27'-1"	23'-8"	21'-2"	18'-6"	15'-7"	19'-3"	16'-10"	14'-2"	17'-10"	15'-7"	13'-2"	16'-10"	14'-8"	12'-5"	16'-0"	13'-11"	11'-9"	15'-3"	13'-4"	11'-3"
	24		29'-10"	23'-8"	20'-8"	18'-6"	16'-2"	13'-8"	16'-10"	14'-8"	12'-5"	15'-7"	13'-8"	11'-6"	14'-8"	12'-10"	10'-10"	13'-11"	12'-2"	10'-3"	13'-4"	11'-8"	9'-10"
362S300-332	12	33	-	-	-	-	-	-	-	-	-	-	-	-	-	-	-	-	-	-	-	-	
	16		-	-	-	-	-	-	-	-	-	-	-	-	-	-	-	-	-	-	-	-	-
	24		-	-	-	-	-	-	-	-	-	-	-	-	-	-	-	-	-	-	-	-	-
362S300-432	12	33	-	-	-	-	-	-	-	-	-	-	-	-	-	-	-	-	-	-	-	-	
	16		-	-	-	-	-	-	-	-	-	-	-	-	-	-	-	-	-	-	-	-	-
	24		-	-	-	-	-	-	-	-	-	-	-	-	-	-	-	-	-	-	-	-	-
362S300-54	12	33	33'-1"	26'-3"	22'-11"	20'-6"	17'-11"	15'-1"	18'-8"	16'-3"	13'-9"	17'-4"	15'-1"	12'-9"	16'-3"	14'-3"	12'-0"	15'-3"	13'-6"	11'-5"	14'-3"	12'-11"	10'-11"
	16		30'-1"	23'-10"	20'-10"	18'-8"	16'-3"	13'-9"	16'-11"	14'-10"	12'-6"	15'-7"	13'-9"	11'-7"	14'-3"	12'-11"	10'-11"	13'-2"	12'-3"	10'-4"	12'-4"	11'-9"	9'-11"
	24		26'-3"	20'-10"	18'-3"	16'-3"	14'-3"	12'-0"	14'-3"	12'-11"	10'-11"	12'-9"	12'-0"	10'-1"	11'-8"	11'-3"	9'-6"	10'-9"	10'-9"	9'-1"	10'-1"	10'-1"	8'-8"
362S300-54	12	50	32'-6"	25'-10"	22'-7"	20'-2"	17'-7"	14'-10"	18'-4"	16'-0"	13'-6"	17'-0"	14'-10"	12'-6"	16'-0"	14'-0"	11'-9"	13'-3"	11'-2"	14'-6"	12'-8"	10'-8"	
	16		29'-6"	23'-5"	20'-6"	18'-4"	16'-0"	13'-6"	16'-8"	14'-6"	12'-3"	15'-5"	13'-6"	11'-5"	14'-6"	12'-8"	10'-8"	13'-10"	12'-1"	10'-2"	13'-2"	11'-6"	9'-9"
	24		25'-10"	20'-6"	17'-11"	16'-0"	14'-0"	11'-9"	14'-6"	12'-8"	10'-8"	13'-6"	11'-9"	9'-11"	12'-8"	11'-1"	9'-4"	12'-1"	10'-6"	8'-11"	11'-6"	10'-1"	8'-6"
362S300-68	12	50	35'-4"	28'-1"	24'-6"	21'-11"	19'-2"	16'-2"	19'-11"	17'-5"	14'-8"	18'-6"	16'-2"	13'-7"	17'-5"	15'-2"	12'-10"	16'-6"	14'-5"	12'-2"	15'-10"	13'-10"	11'-8"
	16		32'-1"	25'-6"	22'-3"	19'-11"	17'-5"	14'-8"	18'-1"	15'-10"	13'-4"	16'-9"	14'-8"	12'-4"	15'-10"	13'-10"	11'-8"	15'-0"	13'-1"	11'-1"	14'-4"	12'-6"	10'-7"
	24		28'-1"	22'-3"	19'-5"	17'-5"	15'-2"	12'-10"	15'-10"	13'-10"	11'-8"	14'-8"	12'-10"	10'-10"	13'-10"	12'-1"	10'-2"	13'-1"	11'-5"	9'-8"	12'-6"	10'-11"	9'-3"
362S300-97	12	50	39'-4"	31'-3"	27'-3"	24'-5"	21'-4"	18'-0"	22'-2"	19'-4"	16'-4"	20'-7"	18'-0"	15'-2"	19'-4"	16'-11"	14'-3"	18'-5"	16'-1"	13'-7"	17'-7"	15'-4"	13'-0"
	16		35'-9"	28'-5"	24'-10"	22'-2"	19'-4"	16'-4"	20'-2"	17'-7"	14'-10"	18'-8"	16'-4"	13'-9"	17'-7"	15'-4"	13'-0"	16'-9"	14'-7"	12'-4"	16'-0"	14'-0"	11'-9"
	24		31'-3"	24'-10"	21'-8"	19'-4"	16'-11"	14'-3"	17'-7"	15'-4"	13'-0"	16'-4"	14'-3"	12'-0"	15'-4"	13'-5"	11'-4"	14'-7"	12'-9"	10'-9"	14'-0"	12'-2"	10'-3"
400S137-33	12	33	25'-1"	19'-11"	17'-5"	15'-4"	13'-7"	11'-6"	13'-4"	12'-4"	10'-5"	11'-11"	11'-6"	9'-8"	10'-10"	10'-9"	9'-1"	10'-1"	8'-8"	9'-5"	9'-5"	8'-3"	
	16		22'-10"	18'-1"	15'-10"	13'-4"	12'-4"	10'-5"	11'-6"	11'-3"	9'-6"	10'-4"	8'-9"	9'-5"	8'-3"	8'-9"	8'-9"	7'-10"	6'-8"	8'-2"	8'-2"	7'-6"	
	24		18'-10"	15'-10"	13'-10"	10'-10"	10'-9"	9'-1"	9'-5"	9'-5"	8'-3"	8'-5"	8'-5"	7'-8"	7'-8"	7'-8"	7'-3"	7'-1"	6'-10"	6'-8"	6'-8"	6'-7"	
400S137-43	12	33	27'-4"	21'-8"	18'-11"	16'-11"	14'-9"	12'-6"	15'-5"	13'-5"	11'-4"	14'-0"	12'-6"	10'-6"	12'-9"	11'-9"	9'-11"	11'-10"	11'-2"	9'-5"	11'-1"	10'-8"	9'-0"
	16		24'-10"	19'-8"	17'-2"	15'-5"	13'-5"	11'-4"	13'-6"	12'-2"	10'-4"	12'-1"	11'-4"	9'-7"	11'-1"	10'-8"	9'-0"	10'-3"	10'-2"	8'-6"	9'-7"	9'-7"	8'-2"
	24		21'-8"	17'-2"	15'-0"	12'-9"	11'-9"	9'-11"	11'-1"	10'-8"	9'-0"	9'-11"	9'-11"	8'-4"	9'-0"	9'-0"	7'-10"	8'-4"	7'-6"	7'-10"	7'-10"	7'-2"	
400S137-54	12	33	29'-3"	23'-3"	20'-3"	18'-1"	15'-10"	13'-4"	16'-6"	14'-5"	12'-2"	15'-3"	13'-4"	11'-3"	14'-4"	12'-7"	10'-7"	13'-4"	11'-11"	10'-1"	12'-5"	11'-5"	9'-8"
	16		26'-7"	21'-1"	18'-5"	16'-6"	14'-5"	12'-2"	15'-0"	13'-1"	11'-0"	13'-7"	12'-2"	10'-3"	12'-5"	11'-5"	9'-8"	11'-6"	10'-10"	9'-2"	10'-9"	10'-4"	8'-9"
	24		23'-3"	18'-5"	16'-1"	14'-4"	12'-7"	10'-7"	12'-5"	11'-5"	9'-8"	11'-1"	10'-7"	8'-11"	10'-1"	10'-0"	8'-5"	9'-4"	8'-0"	8'-9"	8'-9"	7'-8"	
400S137-54	12	50	29'-3"	23'-3"	20'-3"	18'-1"	15'-10"	13'-4"	16'-6"	14'-5"	12'-2"	15'-3"	13'-4"	11'-3"	14'-5"	12'-7"	10'-7"	13'-8"	11'-11"	10'-1"	13'-1"	11'-5"	9'-8"
	16		26'-7"	21'-1"	18'-5"	16'-6"	14'-5"	12'-2"	15'-0"	13'-1"	11'-0"	13'-11"	12'-2"	10'-3"	13'-1"	11'-5"	9'-8"	12'-5"	10'-10"	9'-2"	11'-10"	10'-4"	8'-9"
	24		23'-3"	18'-5"	16'-1"	14'-4"	12'-7"	10'-7"	12'-5"	11'-5"	9'-8"	12'-2"	10'-7"	8'-11"	11'-5"	10'-0"	8'-5"	10'-10"	9'-6"	8'-0"	10'-4"	9'-1"	7'-8"
400S137-68	12	50	31'-3"	24'-10"	21'-8"	19'-5"	16'-11"	14'-3"	17'-7"	15'-5"	13'-0"	16'-4"	13'-3"	12'-1"	15'-5"	13'-4"	11'-4"	14'-7"	12'-9"	10'-9"	14'-0"	12'-2"	10'-4"
	16		28'-5"	22'-7"	19'-8"	17'-7"	15'-5"	13'-0"	16'-0"	14'-0"	11'-9"	14'-10"	13'-0"	10'-11"	14'-0"	12'-2"	10'-4"	13'-3"	11'-7"	9'-9"	12'-8"	11'-1"	9'-4"
	24		24'-10"	19'-8"	17'-2"	15'-5"	13'-5"	11'-4"	14'-0"	12'-2"	10'-4"	13'-0"	11'-4"	9'-7"	12'-2"	10'-8"	9'-0"	11'-3"	10'-2"	8'-7"	11'-1"	9'-8"	8'-2"
400S162-33	12	33	26'-3"	20'-10"	18'-3"	16'-3"	14'-3"	12'-0"	14'-3"	12'-11"	10'-11"	12'-9"	12'-0"	10'-1"	11'-8"	11'-4"	9'-6"	10'-9"	10'-9"	9'-1"	10'-1"	10'-1"	8'-8"
	16		23'-11"	18'-11"	16'-7"	14'-3"	12'-11"	10'-11"	12'-4"	11'-9"	9'-11"	10'-11"	9'-2"	10'-1"	10'-1"	8'-8"	9'-4"	8'-3"	9'-4"	8'-3"	8'-9"	8'-9"	7'-10"
	24		20'-2"	16'-7"	14'-6"	11'-4"	9'-6"	10'-1"	10'-1"	8'-8"	9'-0"	9'-0"	8'-0"	8'-3"	7'-7"	7'-8"	7'-8"	6'-10"	6'-8"	7'-2"	7'-2"	6'-10"	
400S162-43	12	33	28'-7"	22'-8"	19'-10"	17'-9"	15'-6"	13'-1"	16'-1"	14'-1"	11'-10"	14'-11"	13'-1"	11'-0"	13'-9"	12'-3"	10'-4"	12'-8"	11'-8"	9'-10"	11'-11"	11'-2"	9'-5"
	16		26'-0"	20'-7"	18'-0"	16'-1"	14'-1"	11'-10"	14'-7"	12'-9"	10'-9"	13'-0"	11'-10"	10'-0"	11'-11"	11'-2"	9'-5"	11'-0"	10'-7"	8'-11"	10'-5"	10'-2"	8'-7"
	24		22'-8"	18'-0"	15'-9"	13'-9"	12'-3"	10'-4"	11'-11"	11'-2"	9'-5"	10'-8"	10'-4"	8'-9"	9'-8"	8'-3"	9'-0"	9'-0"	7'-10"	8'-3"	8'-5"	8'-5"	7'-6"
400S162-54	12	33	30'-8"	24'-4"	21'-3"	19'-0"	16'-7"	14'-0"	17'-3"	15'-1"	12'-9"	16'-0"	14'-0"	11'-10"	15'-1"	13'-2"	11'-1"	14'-3"	12'-6"	10'-7"	13'-4"	12'-0"	10'-1"
	16		27'-10"	22'-1"	19'-4"	17'-3"	15'-1"	12'-9"	15'-8"	13'-8"	11'-7"	14'-7"	12'-9"	10'-9"	13'-4"	12'-0"	10'-1"	12'-4"	11'-4"	9'-7"	11'-6"	10'-10"	9'-2"
	24		24'-4"	19'-4"	16'-10"	15'-1"	13'-2"	11'-1"	13'-4"	12'-0"	10'-1"	11'-11"	9'-4"	10'-10"	10'-5"	8'-10"	10'-1"	11'-11"	9'-11"	8'-5"	9'-5"	9'-5"	8'-0"
400S162-54	12	50	30'-8"	24'-4"	21'-3"	19'-0"	16'-7"	14'-0"	17'-3"	15'-1"	12'-9"	16'-0"	14'-0"	11'-10"	15'-1"	13'-2"	11'-1"	14'-4"	12'-6"	10'-7"	13'-8"	12'-0"	10'-1"
	16		27'-10"	22'-1"	19'-4"	17'-3"	15'-1"	12'-9"	15'-8"	13'-8"	11'-7"	14'-7"	12'-9"	10'-9"	13'-8"	12'-0"	10'-1"	13'-0"	11'-4"	9'-7"	12'-5"	10'-10"	9'-2"
	24		24'-4"	19'-4"	16'-10"	15'-1"	13'-2"	11'-1"	13'-8"	12'-0"	10'-1"	11'-11"	9'-4"	12'-0"	10'-5"	8'-10"	11'-4"	9'-11"	8'-5"	10'-10"	9'-6"	8'-0"	
400S162-68	12	50	32'-10"	26'-0"	22'-9"	20'-4"	17'-9"	15'-0"	18'-6"	16'-2"	13'-7"	17'-2"	15'-0"	12'-8"	16'-2"	14'-1"	11'-11"	15'-4"	13'-5"	11'-4"	14'-8"	12'-10"	10'-10"
	16		29'-0"	23'-8"	20'-8"	18'-6"	16'-2"	13'-7"	16'-9"	14'-8"	12'-4"	15'-7"	13'-7"	11'-6"	14'-8"	12'-10"	10'-10"	13'-11"	12'-2"	10'-3"	13'-4"	11'-8"	9'-10"

Curtain Wall – Limiting Wall Heights (Continued)

Stud Member	Spacing	Fy (ksi)	5 psf			15 psf			20 psf			25 psf			30 psf			35 psf			40 psf			
			L/120	L/240	L/360	L/120	L/240	L/360	L/120	L/240	L/360	L/120	L/240	L/360	L/120	L/240	L/360	L/120	L/240	L/360	L/120	L/240	L/360	
400S250-33 ²	12	33	-	-	-	-	-	-	-	-	-	-	-	-	-	-	-	-	-	-	-	-	-	
	16		-	-	-	-	-	-	-	-	-	-	-	-	-	-	-	-	-	-	-	-	-	-
	24		-	-	-	-	-	-	-	-	-	-	-	-	-	-	-	-	-	-	-	-	-	-
400S250-43	12	33	31'-9"	25'-3"	22'-0"	19'-8"	17'-2"	14'-6"	17'-11"	15'-8"	13'-2"	16'-6"	14'-6"	12'-3"	15'-1"	13'-8"	11'-6"	13'-11"	13'-0"	10'-11"	13'-0"	12'-5"	10'-6"	
	16		28'-10"	22'-11"	20'-0"	17'-11"	15'-8"	13'-2"	16'-0"	14'-2"	12'-0"	14'-3"	13'-2"	11'-1"	13'-0"	12'-5"	10'-6"	12'-1"	11'-9"	9'-11"	11'-3"	11'-3"	9'-6"	
	24		25'-3"	20'-0"	17'-6"	15'-1"	13'-8"	11'-6"	13'-0"	12'-5"	10'-6"	11'-8"	11'-6"	9'-9"	10'-8"	9'-2"	9'-10"	9'-10"	8'-8"	8'-8"	9'-3"	9'-3"	8'-4"	
400S250-54	12	33	34'-1"	27'-1"	23'-8"	21'-2"	18'-6"	15'-7"	19'-2"	16'-9"	14'-2"	17'-10"	15'-7"	13'-2"	16'-9"	14'-8"	12'-4"	15'-10"	13'-11"	11'-9"	14'-10"	13'-4"	11'-3"	
	16		31'-0"	24'-7"	21'-6"	19'-2"	16'-9"	14'-2"	17'-5"	15'-3"	12'-10"	16'-2"	14'-2"	11'-11"	14'-10"	13'-4"	11'-3"	13'-9"	12'-8"	10'-8"	12'-10"	12'-1"	10'-2"	
	24		27'-1"	21'-6"	18'-9"	16'-9"	14'-8"	12'-4"	14'-10"	13'-4"	11'-3"	13'-3"	12'-4"	10'-5"	12'-1"	11'-8"	9'-10"	11'-3"	11'-1"	9'-4"	10'-6"	10'-6"	8'-11"	
400S250-54	12	50	34'-1"	27'-0"	23'-7"	21'-1"	18'-5"	15'-7"	19'-2"	16'-9"	14'-1"	17'-10"	15'-7"	13'-1"	16'-9"	14'-8"	12'-4"	15'-11"	13'-11"	11'-9"	15'-3"	13'-4"	11'-3"	
	16		30'-11"	24'-7"	21'-5"	19'-2"	16'-9"	14'-1"	17'-5"	15'-3"	12'-10"	16'-2"	14'-1"	11'-11"	15'-3"	13'-4"	11'-3"	14'-5"	12'-8"	10'-8"	13'-10"	12'-1"	10'-2"	
	24		27'-0"	21'-5"	18'-9"	16'-9"	14'-8"	12'-4"	15'-3"	13'-4"	11'-3"	14'-1"	12'-4"	10'-5"	13'-4"	11'-7"	9'-10"	12'-8"	11'-0"	9'-4"	12'-1"	10'-7"	8'-11"	
400S250-68	12	50	36'-7"	29'-0"	25'-4"	22'-8"	19'-10"	16'-8"	20'-7"	18'-0"	15'-2"	19'-1"	16'-8"	14'-1"	18'-0"	15'-9"	13'-3"	17'-1"	14'-11"	12'-7"	16'-4"	14'-3"	12'-1"	
	16		33'-3"	26'-4"	23'-0"	20'-7"	18'-0"	15'-2"	18'-9"	16'-4"	13'-9"	17'-4"	15'-2"	12'-10"	16'-4"	14'-3"	12'-1"	15'-6"	13'-7"	11'-5"	14'-10"	13'-0"	10'-11"	
	24		29'-0"	23'-0"	20'-2"	18'-0"	15'-9"	13'-3"	16'-4"	14'-3"	12'-1"	15'-2"	13'-3"	11'-2"	14'-3"	12'-6"	10'-6"	13'-7"	11'-10"	10'-0"	13'-0"	11'-4"	9'-7"	
400S250-97	12	50	40'-7"	32'-2"	28'-1"	25'-2"	21'-11"	18'-6"	22'-10"	19'-11"	16'-10"	21'-2"	18'-6"	15'-7"	19'-11"	17'-5"	14'-8"	18'-11"	16'-7"	14'-0"	18'-2"	15'-10"	13'-4"	
	16		36'-10"	29'-3"	25'-7"	22'-10"	19'-11"	16'-10"	20'-9"	18'-2"	15'-3"	19'-3"	16'-10"	14'-2"	18'-2"	15'-10"	13'-4"	17'-3"	15'-0"	12'-8"	16'-6"	14'-5"	12'-2"	
	24		32'-2"	25'-7"	22'-4"	19'-11"	17'-5"	14'-8"	18'-2"	15'-10"	13'-4"	16'-10"	14'-8"	12'-5"	15'-10"	13'-10"	11'-8"	15'-0"	13'-2"	11'-1"	14'-5"	12'-7"	10'-7"	
400S300-33 ²	12	33	-	-	-	-	-	-	-	-	-	-	-	-	-	-	-	-	-	-	-	-		
	16		-	-	-	-	-	-	-	-	-	-	-	-	-	-	-	-	-	-	-	-	-	
	24		-	-	-	-	-	-	-	-	-	-	-	-	-	-	-	-	-	-	-	-	-	
400S300-43 ²	12	33	-	-	-	-	-	-	-	-	-	-	-	-	-	-	-	-	-	-	-	-		
	16		-	-	-	-	-	-	-	-	-	-	-	-	-	-	-	-	-	-	-	-	-	
	24		-	-	-	-	-	-	-	-	-	-	-	-	-	-	-	-	-	-	-	-	-	
400S300-54	12	33	35'-7"	28'-3"	24'-8"	22'-1"	19'-3"	16'-3"	20'-1"	17'-6"	14'-9"	18'-7"	16'-3"	13'-9"	17'-6"	15'-4"	12'-11"	16'-2"	14'-6"	12'-3"	15'-2"	13'-11"	11'-9"	
	16		32'-4"	25'-8"	22'-5"	20'-1"	17'-6"	14'-9"	18'-3"	15'-11"	13'-5"	16'-7"	14'-9"	12'-6"	15'-2"	13'-11"	11'-9"	14'-0"	13'-3"	11'-2"	13'-1"	12'-8"	10'-8"	
	24		28'-3"	22'-9"	19'-7"	17'-6"	15'-4"	12'-11"	15'-2"	13'-11"	11'-9"	13'-6"	12'-11"	10'-11"	12'-4"	12'-2"	10'-3"	11'-5"	11'-5"	9'-9"	10'-8"	10'-8"	9'-4"	
400S300-54	12	50	35'-0"	27'-5"	24'-3"	21'-8"	18'-11"	16'-0"	19'-8"	17'-3"	14'-6"	18'-3"	16'-0"	13'-6"	16'-0"	13'-6"	10'-7"	12'-8"	16'-4"	14'-3"	12'-1"	15'-8"	13'-8"	
	16		31'-9"	25'-3"	22'-1"	19'-8"	17'-3"	14'-6"	17'-11"	15'-8"	13'-2"	16'-7"	14'-6"	12'-3"	15'-8"	13'-8"	11'-6"	14'-10"	13'-0"	10'-11"	14'-3"	12'-5"	10'-6"	
	24		27'-9"	22'-1"	19'-3"	17'-3"	15'-0"	12'-8"	15'-8"	13'-8"	11'-6"	14'-6"	12'-8"	10'-8"	13'-8"	11'-11"	10'-1"	13'-0"	11'-4"	9'-7"	12'-4"	10'-10"	9'-2"	
400S300-68	12	50	38'-0"	30'-2"	26'-4"	23'-7"	20'-7"	17'-4"	21'-5"	18'-9"	15'-9"	19'-11"	17'-4"	14'-8"	18'-9"	16'-4"	13'-9"	17'-9"	15'-6"	13'-1"	17'-0"	14'-10"	12'-6"	
	16		34'-7"	27'-5"	24'-0"	21'-5"	18'-9"	15'-9"	19'-6"	17'-0"	14'-4"	18'-1"	15'-9"	13'-4"	17'-0"	14'-10"	12'-6"	16'-2"	14'-1"	11'-11"	15'-5"	13'-6"	11'-5"	
	24		30'-2"	24'-0"	20'-11"	18'-9"	16'-4"	13'-9"	17'-0"	14'-10"	12'-6"	15'-9"	13'-9"	11'-8"	14'-10"	13'-0"	10'-11"	14'-1"	12'-4"	10'-5"	13'-6"	11'-9"	9'-11"	
400S300-97	12	50	42'-5"	33'-8"	29'-5"	26'-3"	22'-11"	19'-4"	23'-10"	20'-10"	17'-7"	22'-2"	19'-4"	16'-4"	20'-10"	18'-3"	15'-4"	19'-10"	17'-4"	14'-7"	18'-11"	16'-7"	13'-11"	
	16		38'-6"	30'-7"	26'-8"	23'-10"	20'-10"	17'-7"	21'-8"	18'-11"	16'-0"	20'-2"	17'-7"	14'-10"	18'-11"	16'-7"	13'-11"	18'-0"	15'-9"	13'-3"	17'-3"	15'-0"	12'-8"	
	24		33'-8"	26'-8"	23'-4"	20'-10"	18'-3"	15'-4"	18'-11"	16'-7"	13'-11"	17'-7"	15'-4"	12'-11"	16'-7"	14'-5"	12'-2"	15'-9"	13'-9"	11'-7"	15'-0"	13'-2"	11'-1"	
550S162-33	12	33	33'-8"	26'-9"	23'-4"	20'-11"	18'-3"	15'-5"	18'-3"	16'-7"	14'-0"	16'-4"	15'-5"	13'-0"	14'-11"	14'-6"	12'-3"	13'-10"	13'-9"	11'-7"	12'-11"	12'-11"	11'-1"	
	16		30'-7"	24'-4"	21'-3"	18'-3"	16'-7"	14'-0"	15'-10"	15'-1"	12'-8"	14'-2"	14'-0"	11'-9"	12'-11"	12'-11"	12'-0"	12'-0"	10'-6"	11'-2"	11'-2"	10'-1"		
	24		25'-10"	21'-3"	18'-7"	14'-11"	14'-6"	12'-3"	12'-11"	12'-11"	11'-1"	11'-7"	11'-7"	10'-4"	10'-7"	10'-7"	9'-8"	9'-9"	9'-2"	9'-2"	8'-10"	8'-10"	8'-10"	
550S162-43	12	33	36'-8"	29'-1"	25'-5"	22'-9"	19'-10"	16'-9"	20'-8"	18'-1"	15'-3"	19'-2"	16'-9"	14'-2"	17'-11"	15'-9"	13'-4"	16'-7"	15'-0"	12'-8"	15'-6"	14'-4"	12'-1"	
	16		33'-4"	26'-5"	23'-1"	20'-8"	18'-1"	15'-3"	18'-9"	16'-5"	13'-10"	17'-0"	15'-3"	12'-10"	15'-6"	14'-4"	12'-1"	14'-4"	13'-7"	11'-6"	13'-5"	13'-0"	11'-0"	
	24		29'-1"	23'-1"	20'-2"	17'-11"	15'-9"	13'-4"	15'-6"	14'-4"	12'-1"	13'-11"	13'-4"	11'-3"	12'-8"	12'-6"	10'-7"	11'-9"	10'-0"	11'-0"	11'-0"	10'-3"	9'-7"	
550S162-54	12	33	39'-4"	31'-3"	27'-3"	24'-5"	21'-4"	18'-0"	22'-2"	19'-4"	16'-4"	20'-7"	18'-0"	15'-2"	19'-4"	16'-11"	14'-3"	18'-5"	16'-1"	13'-7"	17'-7"	15'-4"	13'-0"	
	16		35'-9"	28'-5"	24'-10"	22'-2"	19'-4"	16'-4"	20'-2"	17'-7"	14'-10"	18'-8"	16'-4"	13'-9"	17'-7"	15'-4"	13'-0"	16'-4"	14'-7"	12'-4"	15'-3"	14'-0"	11'-9"	
	24		31'-3"	24'-10"	21'-8"	19'-4"	16'-11"	14'-3"	17'-7"	15'-4"	13'-0"	15'-9"	14'-3"	12'-0"	14'-5"	11'-4"	13'-4"	12'-9"	10'-9"	12'-6"	12'-2"	10'-3"	10'-3"	
550S162-54	12	50	39'-4"	31'-3"	27'-3"	24'-5"	21'-4"	18'-0"	22'-2"	19'-4"	16'-4"	20'-7"	18'-0"	15'-2"	19'-4"	16'-11"	14'-3"	18'-5"	16'-1"	13'-7"	17'-7"	15'-4"	13'-0"	
	16		35'-9"	28'-5"	24'-10"	22'-2"	19'-4"	16'-4"	20'-2"	17'-7"	14'-10"	18'-8"	16'-4"	13'-9"	17'-7"	15'-4"	13'-0"	16'-9"	14'-7"	12'-4"	16'-0"	14'-0"	11'-9"	
	24		31'-3"	24'-10"	21'-8"	19'-4"	16'-11"	14'-3"	17'-7"	15'-4"	13'-0"	16'-4"	14'-3"	12'-0"	15'-4"	13'-5"	11'-4"	14'-7"	12'-9"	10'-9"	14'-0"	12'-2"	10'-3"	
550S162-68	12	50	42'-2"	33'-6"	29'-3"	26'-2"	22'-10"	19'-3"	23'-9"	20'-9"	17'-6"	22'-1"	19'-3"	16'-3"	20'-9"	18'-2"	15'-3"	19'-7"	17'-3"	14'-6"	18'-10"	16'-6"	13'-11"	
	16		38'-4"	30'-5"	26'-7"	23'-9"	20'-9"	17'-6"	21'-7"	18'-10"	15'-11"	20'-0"	17'-6"	14'-9"	18'-10"	16'-6"	13'-11"	17'-11"	15'-8"	13'-2"	17'-2"	15'-0"	12'-7"	
	24		33'-6"	26'-7"	23'-3"	20'-9"	18'-2"	15'-3"	18'-10"	16'-6"	13'-11"	17'-6"	15'-3"	12'-11"	16'-6"	14'-5"	12'-2"	15'-8"	13'-8"	11'-6"	15'-0"	13'-1"	11'-0"	
550S162-97	12	50	46'-9"	37'-1"	32'-5"	28'-11"	25'-4"	21'-4"	26'-4"	23'-0"	19'-5"	24'-5"	21'-4"	18'-0"	23'-0"	20'-1"	16'-11"	21'-10"	19'-1"	16'-1"	20'-11"	18'-3"	15'-5"	
	16		42'-5"	33'-8"	29'-5"	26'-4"	23'-0"	19'-5"	23'-11"	20'-11"	17'-7"	22'-2"	19'-5"	16'-4"	20'-11"	18'-3"	15'-5"	19'-10"	17'-4"	14'-7"	19'-0"	16'-7"	14'-0"	
	24		37'-1"	29'-5"	25'-9"	23'-0"	20'-1"	16'-11"	20'-11"	18'-3"	15'-5"	19'-5"	16'-11"	14'-3"	18'-3"	15'-11"	13'-5"	17'-4"	15'-2"	12'-9"	16'-7"	14'-6"	12'-3"	
550S200-33	12	33	35'-4"	28'-0"	24'-6"	21'-11"	19'-1"	16'-2"	19'-1"	17'-4"	14'-8"	17'-1"	16'-2"	13'-7"	15'-7"	15'-2"	12'-10"	14'-5"	14'-5"	12'-2"	13'-6"	13'-6"	11'-8"	
	16		32'-1"	25'-6"	22'-3"	19'-1"	17'-4"	14'-8"	16'-6"	15'-9"	13'-4"	14'-9"	14'-8"	12'-4"	13'-6"	13'-6"	11'-8"	12'-6"	12'-6"	11'-1"	11'-8"	11'-8"	10'-7"	
	24		27'-0"	22'-3"	19'-5"	15'-7"	15'-2"	12'-10"	13'-6"	13'-6"	11'-8"	12'-1"	12'-1"	10'-10"	11'-0"	11'-0"	10'-2"	10'-2"	9'-8"	9'-6"	9'-6"	9'-3"	9'-3"	
550S200-43	12	33	38'-7"	30'-7"	26'-9"	23'-11"	20'-11"	17'-7"	21'-9"	19'-0"	16'-0"	20'-2"	17'-7"	14'-10"	18'-5"	16'-7"	14'-0"	17'-0"	15'-9"	13'-3"	15'-11"	15'-1"	12'-8"	

Curtain Wall – Limiting Wall Heights (Continued)

Stud Member	Spacing	Fy (ksi)	5 psf			15 psf			20 psf			25 psf			30 psf			35 psf			40 psf			
			L/120	L/240	L/360	L/120	L/240	L/360	L/120	L/240	L/360	L/120	L/240	L/360	L/120	L/240	L/360	L/120	L/240	L/360	L/120	L/240	L/360	
600S162-43	12	33	37'-8"	29'-11"	26'-2"	23'-4"	20'-5"	17'-3"	20'-6"	18'-6"	15'-8"	18'-4"	17'-3"	14'-6"	16'-8"	16'-2"	13'-8"	15'-6"	13'-0"	14'-6"	14'-6"	12'-5"	14'-6"	12'-5"
			34'-3"	27'-2"	23'-9"	20'-6"	18'-6"	15'-8"	17'-9"	16'-10"	14'-3"	15'-10"	15'-8"	13'-2"	14'-6"	14'-6"	12'-5"	13'-5"	11'-9"	12'-6"	12'-6"	11'-3"	12'-6"	11'-3"
			28'-11"	23'-9"	20'-9"	16'-8"	16'-2"	13'-8"	14'-6"	14'-6"	12'-5"	12'-11"	12'-11"	11'-6"	11'-10"	11'-10"	10'-10"	10'-11"	10'-11"	10'-4"	10'-3"	10'-3"	9'-10"	9'-10"
600S162-54	12	33	40'-5"	32'-1"	28'-0"	25'-1"	21'-11"	18'-5"	22'-9"	19'-11"	16'-9"	21'-2"	18'-5"	15'-7"	19'-11"	17'-4"	14'-8"	18'-11"	16'-6"	13'-11"	18'-1"	15'-9"	13'-4"	16'-6"
			36'-9"	29'-2"	25'-6"	22'-9"	19'-11"	16'-9"	20'-8"	18'-1"	15'-3"	19'-2"	16'-9"	14'-2"	18'-1"	15'-9"	13'-4"	17'-2"	15'-0"	12'-8"	16'-5"	14'-4"	12'-1"	16'-6"
			32'-1"	25'-6"	22'-3"	19'-1"	17'-4"	14'-8"	16'-6"	15'-9"	13'-4"	14'-9"	14'-8"	12'-4"	13'-6"	13'-6"	11'-8"	12'-6"	12'-6"	11'-1"	11'-8"	11'-8"	10'-7"	10'-7"
600S162-54	16	50	36'-9"	29'-2"	25'-6"	22'-9"	19'-11"	16'-9"	20'-8"	18'-1"	15'-3"	19'-2"	16'-9"	14'-2"	18'-1"	15'-9"	13'-4"	17'-2"	15'-0"	12'-8"	16'-5"	14'-4"	12'-1"	16'-6"
			32'-1"	25'-6"	22'-3"	19'-1"	17'-4"	14'-8"	16'-6"	15'-9"	13'-4"	14'-9"	14'-8"	12'-4"	13'-6"	13'-6"	11'-8"	12'-6"	12'-6"	11'-1"	11'-8"	11'-8"	10'-7"	10'-7"
			43'-4"	34'-4"	30'-0"	26'-10"	23'-5"	19'-9"	24'-5"	21'-4"	18'-0"	22'-8"	19'-9"	16'-8"	21'-4"	18'-7"	15'-8"	20'-3"	17'-8"	14'-11"	19'-4"	16'-11"	14'-3"	14'-3"
600S162-68	16	50	39'-4"	31'-3"	27'-3"	24'-5"	21'-4"	18'-0"	22'-2"	19'-4"	16'-4"	20'-7"	18'-0"	15'-2"	19'-4"	16'-11"	14'-3"	18'-5"	16'-1"	13'-7"	17'-7"	15'-4"	12'-11"	12'-11"
			34'-4"	27'-3"	23'-10"	21'-4"	18'-7"	15'-8"	19'-4"	16'-11"	14'-3"	18'-0"	15'-8"	13'-3"	16'-11"	14'-9"	12'-5"	16'-1"	14'-0"	11'-10"	15'-4"	13'-5"	11'-4"	11'-4"
			47'-11"	38'-0"	33'-3"	29'-8"	25'-11"	21'-10"	27'-0"	23'-7"	19'-10"	25'-0"	21'-10"	18'-5"	23'-7"	20'-7"	17'-4"	22'-5"	19'-7"	16'-6"	21'-5"	18'-8"	15'-9"	15'-9"
600S162-97	12	50	43'-6"	34'-6"	30'-2"	27'-0"	23'-7"	19'-10"	24'-6"	21'-5"	18'-1"	22'-9"	19'-10"	16'-9"	21'-5"	18'-8"	15'-9"	20'-4"	17'-9"	15'-0"	19'-5"	17'-0"	14'-4"	14'-4"
			38'-0"	30'-2"	26'-4"	23'-7"	20'-7"	17'-4"	21'-5"	18'-8"	15'-9"	19'-10"	17'-4"	14'-8"	18'-8"	16'-4"	13'-9"	17'-9"	15'-6"	13'-1"	17'-0"	14'-10"	12'-6"	12'-6"
			36'-1"	28'-8"	25'-0"	22'-4"	19'-7"	16'-6"	19'-5"	17'-9"	15'-0"	17'-5"	16'-6"	13'-11"	15'-10"	12'-8"	13'-1"	14'-8"	12'-5"	13'-9"	13'-9"	11'-11"	11'-11"	
600S162-118	16	50	32'-9"	26'-0"	22'-9"	19'-5"	17'-9"	15'-0"	16'-10"	16'-2"	13'-7"	15'-1"	15'-0"	12'-8"	13'-9"	13'-9"	11'-11"	12'-9"	12'-9"	11'-3"	11'-11"	11'-11"	10'-10"	10'-10"
			27'-6"	22'-9"	19'-10"	15'-10"	15'-6"	13'-1"	13'-9"	13'-9"	11'-11"	12'-3"	12'-3"	11'-0"	11'-3"	11'-3"	10'-5"	10'-5"	10'-5"	9'-10"	9'-9"	9'-9"	9'-5"	9'-5"
			39'-4"	31'-2"	27'-3"	24'-4"	21'-3"	17'-11"	22'-2"	19'-4"	16'-4"	20'-7"	17'-11"	15'-2"	19'-0"	16'-11"	14'-3"	17'-7"	16'-1"	13'-6"	16'-6"	16'-6"	15'-4"	12'-11"
600S200-33	16	33	35'-9"	28'-4"	24'-9"	22'-2"	19'-4"	16'-4"	20'-1"	17'-7"	14'-10"	18'-11"	16'-4"	13'-9"	16'-6"	15'-4"	12'-11"	15'-3"	14'-7"	12'-4"	14'-3"	13'-11"	11'-9"	11'-9"
			31'-2"	24'-9"	21'-8"	19'-0"	16'-11"	14'-3"	16'-6"	15'-4"	12'-11"	14'-9"	14'-3"	12'-0"	13'-5"	13'-5"	11'-4"	12'-5"	12'-5"	10'-9"	11'-8"	11'-8"	10'-3"	10'-3"
			42'-2"	33'-6"	29'-3"	26'-2"	22'-10"	19'-3"	23'-9"	20'-9"	17'-6"	22'-1"	19'-3"	16'-3"	20'-9"	18'-1"	15'-3"	19'-8"	17'-3"	14'-6"	18'-9"	16'-6"	13'-11"	13'-11"
600S200-43	16	33	38'-4"	30'-5"	26'-7"	23'-9"	20'-9"	17'-6"	21'-7"	18'-10"	15'-11"	20'-0"	17'-6"	14'-9"	18'-9"	16'-6"	13'-11"	17'-4"	15'-8"	13'-2"	16'-3"	15'-0"	12'-7"	12'-7"
			33'-6"	26'-7"	23'-3"	20'-9"	18'-1"	15'-3"	18'-9"	16'-6"	13'-11"	16'-9"	15'-3"	12'-11"	15'-4"	14'-5"	12'-2"	13'-8"	11'-6"	13'-3"	13'-1"	11'-0"	11'-0"	
			42'-2"	33'-6"	29'-3"	26'-2"	22'-10"	19'-3"	23'-9"	20'-9"	17'-6"	22'-1"	19'-3"	16'-3"	20'-9"	18'-1"	15'-3"	19'-8"	17'-3"	14'-6"	18'-9"	16'-6"	13'-11"	13'-11"
600S200-54	16	33	38'-4"	30'-5"	26'-7"	23'-9"	20'-9"	17'-6"	21'-7"	18'-10"	15'-11"	20'-0"	17'-6"	14'-9"	18'-10"	16'-6"	13'-11"	17'-11"	15'-8"	13'-2"	17'-2"	15'-0"	12'-7"	12'-7"
			33'-6"	26'-7"	23'-3"	20'-9"	18'-1"	15'-3"	18'-10"	16'-6"	13'-11"	17'-6"	15'-3"	12'-11"	16'-6"	14'-5"	12'-2"	13'-8"	11'-6"	15'-0"	13'-1"	11'-0"	11'-0"	
			45'-3"	35'-11"	31'-4"	28'-0"	24'-6"	21'-3"	22'-3"	18'-9"	23'-8"	20'-8"	17'-5"	22'-3"	19'-5"	16'-5"	21'-2"	18'-6"	15'-7"	20'-3"	17'-8"	14'-11"	14'-11"	
600S200-54	16	50	41'-1"	32'-7"	28'-6"	25'-6"	22'-3"	18'-9"	23'-2"	20'-3"	17'-1"	21'-6"	18'-9"	15'-10"	20'-3"	17'-8"	14'-11"	19'-2"	16'-9"	14'-2"	18'-4"	16'-0"	13'-6"	13'-6"
			35'-11"	28'-6"	24'-11"	22'-3"	19'-5"	16'-5"	20'-3"	17'-8"	14'-11"	18'-9"	16'-5"	13'-10"	17'-8"	15'-5"	13'-0"	16'-9"	14'-8"	12'-4"	16'-0"	14'-0"	11'-10"	11'-10"
			50'-1"	39'-9"	34'-9"	31'-1"	27'-2"	22'-11"	28'-3"	24'-8"	20'-10"	26'-2"	22'-11"	19'-4"	24'-8"	21'-6"	18'-2"	23'-5"	20'-5"	17'-3"	22'-5"	19'-7"	16'-6"	16'-6"
600S200-68	16	50	45'-6"	36'-2"	31'-7"	28'-3"	24'-8"	20'-10"	25'-8"	22'-5"	18'-11"	23'-10"	20'-10"	17'-6"	22'-5"	19'-7"	16'-6"	21'-3"	18'-7"	15'-8"	20'-4"	17'-9"	15'-0"	15'-0"
			39'-9"	31'-7"	27'-7"	24'-8"	21'-6"	18'-2"	22'-5"	19'-7"	16'-6"	20'-10"	18'-2"	15'-4"	17'-1"	14'-5"	18'-7"	16'-3"	13'-8"	17'-9"	15'-6"	13'-1"	13'-1"	
			52'-11"	42'-0"	36'-8"	32'-10"	28'-8"	24'-2"	29'-10"	26'-1"	22'-0"	27'-8"	24'-2"	20'-5"	26'-1"	22'-9"	19'-2"	24'-9"	21'-7"	18'-3"	23'-8"	20'-8"	17'-5"	17'-5"
600S200-97	16	50	48'-1"	38'-2"	33'-4"	29'-10"	26'-1"	22'-0"	27'-1"	23'-8"	19'-11"	25'-2"	22'-0"	18'-6"	23'-8"	20'-8"	17'-5"	22'-6"	19'-8"	16'-7"	21'-6"	18'-9"	15'-10"	15'-10"
			42'-0"	33'-4"	29'-2"	26'-1"	22'-9"	19'-2"	23'-8"	20'-8"	17'-5"	22'-0"	19'-2"	16'-2"	20'-8"	18'-1"	15'-3"	19'-8"	17'-2"	14'-6"	18'-9"	16'-5"	13'-10"	13'-10"
			37'-10"	30'-0"	26'-3"	23'-2"	20'-6"	17'-3"	20'-1"	18'-7"	15'-8"	17'-11"	17'-3"	14'-7"	16'-4"	16'-3"	13'-8"	15'-2"	15'-2"	13'-0"	14'-2"	14'-2"	12'-5"	12'-5"
600S200-118	16	50	34'-4"	27'-3"	23'-10"	20'-1"	18'-7"	15'-8"	17'-4"	16'-11"	14'-3"	15'-6"	15'-6"	13'-3"	14'-2"	14'-2"	12'-5"	13'-1"	13'-1"	11'-10"	12'-3"	12'-3"	11'-4"	11'-4"
			28'-4"	23'-10"	20'-10"	16'-4"	16'-3"	13'-8"	14'-2"	14'-2"	12'-5"	12'-8"	12'-8"	11'-7"	11'-7"	10'-11"	10'-11"	10'-9"	10'-9"	10'-4"	10'-0"	10'-0"	9'-11"	9'-11"
			41'-3"	32'-9"	28'-7"	25'-7"	22'-4"	18'-10"	23'-3"	20'-4"	17'-2"	21'-5"	18'-10"	15'-11"	19'-6"	17'-9"	15'-0"	18'-1"	16'-10"	14'-3"	16'-11"	16'-11"	13'-7"	13'-7"
600S250-43	16	33	37'-6"	29'-9"	26'-0"	23'-3"	20'-4"	17'-2"	20'-9"	18'-5"	15'-7"	18'-6"	17'-2"	14'-5"	16'-11"	16'-1"	13'-7"	15'-8"	15'-4"	12'-11"	14'-8"	14'-8"	12'-4"	12'-4"
			32'-9"	26'-0"	22'-9"	19'-6"	17'-9"	15'-0"	16'-11"	16'-1"	13'-7"	15'-2"	15'-0"	12'-7"	13'-10"	13'-10"	11'-11"	12'-9"	12'-9"	11'-3"	12'-0"	12'-0"	10'-9"	10'-9"
			44'-4"	35'-2"	30'-9"	27'-6"	24'-0"	20'-3"	24'-11"	21'-10"	18'-5"	23'-2"	20'-3"	17'-1"	21'-10"	19'-1"	16'-1"	20'-9"	18'-1"	15'-3"	19'-10"	17'-4"	14'-7"	14'-7"
600S250-54	16	33	40'-3"	32'-0"	27'-11"	24'-11"	21'-10"	18'-5"	22'-8"	19'-10"	16'-8"	21'-1"	18'-5"	15'-6"	19'-10"	17'-4"	14'-7"	18'-6"	16'-5"	13'-10"	17'-4"	15'-9"	13'-3"	13'-3"
			35'-2"	27'-11"	24'-5"	21'-10"	19'-1"	16'-1"	19'-10"	17'-4"	14'-7"	17'-10"	16'-1"	13'-7"	16'-4"	15'-1"	12'-9"	15'-1"	14'-4"	12'-1"	14'-2"	13'-9"	11'-7"	11'-7"
			44'-4"	35'-2"	30'-9"	27'-6"	24'-0"	20'-3"	24'-11"	21'-10"	18'-5"	23'-2"	20'-3"	17'-1"	21'-10"	19'-1"	16'-1"	20'-9"	18'-1"	15'-3"	19'-10"	17'-4"	14'-7"	14'-7"
600S250-54	16	50	40'-3"	32'-0"	27'-11"	24'-11"	21'-10"	18'-5"	22'-8"	19'-10"	16'-8"	21'-1"	18'-5"	15'-6"	19'-10"	17'-4"	14'-7"	18'-10"	16'-5"	13'-10"	18'-0"	15'-9"	13'-3"	13'-3"
			35'-2"	27'-11"	24'-5"	21'-10"	19'-1"	16'-1"	19'-10"	17'-4"	14'-7"	18'-5"	16'-1"	13'-7"	17'-4"	15'-1"	12'-9"	16'-5"	14'-4"	12'-1"	15'-9"	13'-9"	11'-7"	11'-7"
			47'-7"	37'-9"	33'-0"	29'-6"	25'-9"	21'-9"	26'-9"	23'-5"	19'-9"	24'-10"	21'-9"	18'-4"	23'-5"	20'-5"	17'-3"	22'-3"	19'-5"	16'-4"	21'-3"	18'-7"	15'-8"	15'-8"
600S250-68	16	50	43'-2"	34'-4"	29'-11"	26'-9"	23'-5"	19'-9"	24'-4"	21'-3"	17'-11"	22'-7"	19'-9"	16'-8"	21'-3"	18'-7"	15'-8"	20'-2"	17'-8"	14'-11"	19'-4"	16'-10"	14'-3"	14'-3"
			37'-9"	29'-11"	26'-2"	23'-5"	20'-5"	17'-3"	21'-3"	18'-7"	15'-8"	19'-9"	17'-3"	14'-6"	18'-7"	16'-3"	13'-8"	17'-8"	15'-5"	13'-0"	16'-10"	14'-9"	12'-5"	12'-5"
			52'-10"	41'-11"	36'-7"	32'-9"	28'-7"	24'-1"	29'-9"	26'-0"	21'-11"	27'-7"	24'-1"	20'-4"	26'-0"	22'-8"	19'-2"	24'-8"	21'-7"	18'-2"	23'-7"	20'-7"	17'-5"	17'-5"
600S250-97	16	50	48'-0"	38'-1"	33'-3"	29'-9"	26'-0"	21'-11"	27'-0"	23'-7"	19'-11"	25'-1"	21'-11"	18'-6"	23'-7"	20'-7"	17'-5"	22'-5"	19'-7"	16'-6"	21'-5"	18'-9"	15'-10"	15'-10"
			41'-11"	33'-3"	29'-1"	26'-0"	22'-8"	19'-2"	23'-7"	20'-7"	17'-5"	21'-11"	19'-2"	16'-2"	20'-7"	18'-0"	15'-2"	19'-7"	17'-1"	14'-5"	18'-9"	16'-4"	13'-10"	13'-10"
			55'-10"	44'-4"	38'-9"	34'-7"	30'-3"	25'-6"	31'-5"</															

Curtain Wall – Limiting Wall Heights (Continued)

Stud Member	Spacing	Fy (ksi)	5 psf			15 psf			20 psf			25 psf			30 psf			35 psf			40 psf		
			L/120	L/240	L/360	L/120	L/240	L/360	L/120	L/240	L/360	L/120	L/240	L/360	L/120	L/240	L/360	L/120	L/240	L/360	L/120	L/240	L/360
600S350-68	12	50	37'-8"	29'-11"	26'-2"	23'-4"	20'-5"	17'-3"	20'-6"	18'-6"	15'-8"	18'-4"	17'-3"	14'-6"	16'-8"	16'-2"	13'-8"	15'-6"	15'-5"	13'-0"	14'-6"	14'-6"	12'-5"
	16		34'-3"	27'-2"	23'-9"	20'-6"	18'-6"	15'-8"	17'-9"	16'-10"	14'-3"	15'-10"	15'-8"	13'-2"	14'-6"	14'-6"	12'-5"	13'-5"	13'-5"	11'-9"	12'-6"	12'-6"	11'-3"
	24		28'-11"	23'-9"	20'-9"	16'-8"	16'-2"	13'-8"	14'-6"	14'-6"	12'-5"	12'-11"	12'-11"	11'-6"	11'-10"	11'-10"	10'-10"	10'-11"	10'-11"	10'-4"	10'-3"	10'-3"	9'-10"
600S350-97	12	50	40'-5"	32'-1"	28'-0"	25'-1"	21'-11"	18'-5"	22'-9"	19'-11"	16'-9"	20'-10"	18'-5"	15'-7"	19'-1"	17'-4"	14'-8"	17'-8"	16'-6"	13'-11"	16'-6"	15'-9"	13'-4"
	16		36'-9"	29'-2"	25'-6"	22'-9"	19'-11"	16'-9"	20'-2"	18'-1"	15'-3"	18'-1"	16'-9"	14'-2"	16'-6"	15'-9"	13'-4"	15'-3"	15'-0"	12'-8"	14'-3"	14'-3"	12'-1"
	24		32'-1"	25'-6"	22'-3"	19'-1"	17'-4"	14'-8"	16'-6"	15'-9"	13'-4"	14'-9"	14'-8"	12'-4"	13'-6"	13'-6"	11'-8"	12'-6"	12'-6"	11'-1"	11'-8"	11'-8"	10'-7"
600S350-118	12	50	40'-5"	32'-1"	28'-0"	25'-1"	21'-11"	18'-5"	22'-9"	19'-11"	16'-9"	20'-10"	18'-5"	15'-7"	19'-1"	17'-4"	14'-8"	18'-11"	16'-6"	13'-11"	18'-1"	15'-9"	13'-4"
	16		36'-9"	29'-2"	25'-6"	22'-9"	19'-11"	16'-9"	20'-8"	18'-1"	15'-3"	19'-2"	16'-9"	14'-2"	18'-1"	15'-9"	13'-4"	17'-2"	15'-0"	12'-8"	16'-5"	14'-4"	12'-1"
	24		32'-1"	25'-6"	22'-3"	19'-11"	17'-4"	14'-8"	18'-1"	15'-9"	13'-4"	16'-9"	14'-8"	12'-4"	15'-9"	13'-9"	11'-8"	14'-9"	13'-1"	11'-1"	13'-10"	12'-6"	10'-7"
800S137-33 ¹	12	33	43'-4"	30'-4"	26'-10"	23'-5"	19'-9"	23'-5"	21'-4"	18'-0"	22'-2"	19'-4"	16'-4"	20'-7"	18'-0"	15'-2"	19'-4"	16'-11"	14'-3"	18'-5"	16'-1"	13'-7"	17'-7"
	16		39'-4"	31'-3"	27'-3"	24'-5"	21'-4"	18'-0"	22'-2"	19'-4"	16'-4"	20'-7"	18'-0"	15'-2"	19'-4"	16'-11"	14'-3"	18'-5"	16'-1"	13'-7"	17'-7"	15'-4"	12'-11"
	24		34'-4"	27'-3"	23'-10"	21'-4"	18'-7"	15'-8"	19'-4"	16'-11"	14'-3"	18'-0"	15'-8"	13'-3"	16'-11"	14'-9"	12'-5"	16'-1"	14'-0"	11'-10"	15'-4"	13'-5"	11'-4"
800S137-43	12	33	47'-11"	38'-0"	33'-3"	29'-8"	25'-11"	21'-10"	27'-0"	23'-7"	19'-10"	25'-0"	21'-10"	18'-5"	23'-7"	17'-4"	22'-5"	19'-7"	17'-4"	22'-5"	19'-7"	16'-10"	15'-9"
	16		43'-6"	34'-6"	30'-2"	27'-0"	23'-7"	19'-10"	24'-6"	21'-5"	18'-1"	22'-9"	19'-10"	16'-9"	21'-5"	18'-8"	15'-9"	20'-4"	17'-9"	15'-0"	19'-5"	17'-0"	14'-4"
	24		38'-0"	30'-2"	26'-4"	23'-7"	17'-4"	21'-5"	18'-8"	15'-9"	19'-10"	17'-4"	14'-8"	16'-4"	13'-9"	18'-9"	15'-6"	13'-1"	17'-0"	14'-10"	12'-6"	11'-11"	10'-10"
800S137-54	12	33	36'-1"	28'-8"	25'-0"	22'-4"	19'-7"	16'-6"	19'-5"	17'-9"	15'-0"	17'-5"	16'-6"	13'-11"	15'-10"	15'-6"	13'-1"	14'-8"	14'-8"	12'-5"	13'-9"	13'-9"	11'-11"
	16		32'-9"	26'-0"	22'-9"	19'-5"	17'-9"	15'-0"	16'-10"	16'-2"	13'-7"	15'-1"	15'-0"	12'-8"	13'-9"	13'-9"	11'-11"	12'-9"	12'-9"	11'-3"	11'-11"	11'-11"	10'-10"
	24		27'-6"	22'-9"	19'-10"	15'-10"	15'-6"	13'-1"	13'-9"	13'-9"	11'-11"	12'-3"	12'-3"	11'-0"	11'-3"	11'-3"	10'-5"	10'-5"	10'-5"	9'-10"	9'-9"	9'-9"	9'-5"
800S137-54	12	50	39'-4"	31'-2"	27'-3"	24'-4"	21'-3"	17'-11"	22'-2"	19'-4"	16'-4"	20'-7"	17'-11"	15'-2"	19'-0"	16'-11"	14'-3"	17'-7"	16'-1"	13'-6"	16'-6"	15'-4"	12'-11"
	16		35'-9"	28'-4"	24'-9"	22'-2"	19'-4"	16'-4"	20'-1"	17'-7"	14'-10"	18'-1"	16'-4"	13'-9"	16'-6"	15'-4"	12'-11"	15'-3"	14'-7"	12'-4"	14'-3"	13'-11"	11'-9"
	24		31'-2"	24'-9"	21'-8"	19'-0"	16'-11"	14'-3"	16'-6"	15'-4"	12'-11"	14'-9"	14'-3"	12'-0"	13'-5"	13'-5"	11'-4"	12'-5"	12'-5"	10'-9"	11'-8"	11'-8"	10'-3"
800S137-68	12	50	42'-2"	33'-6"	29'-3"	26'-2"	22'-10"	19'-3"	23'-9"	20'-9"	17'-6"	22'-1"	19'-3"	16'-3"	20'-9"	18'-1"	15'-3"	19'-8"	17'-3"	14'-6"	18'-9"	16'-6"	13'-11"
	16		38'-4"	30'-5"	26'-7"	23'-9"	20'-9"	17'-6"	21'-7"	18'-10"	15'-11"	20'-0"	17'-6"	14'-9"	18'-10"	16'-6"	13'-11"	17'-4"	15'-8"	13'-2"	16'-3"	15'-0"	12'-7"
	24		33'-6"	26'-7"	23'-3"	20'-9"	18'-1"	15'-3"	18'-9"	16'-6"	13'-11"	16'-9"	15'-3"	12'-11"	15'-4"	14'-5"	12'-2"	14'-2"	13'-8"	11'-6"	13'-3"	13'-1"	11'-0"
800S137-97	12	50	42'-2"	33'-6"	29'-3"	26'-2"	22'-10"	19'-3"	23'-9"	20'-9"	17'-6"	22'-1"	19'-3"	16'-3"	20'-9"	18'-1"	15'-3"	19'-8"	17'-3"	14'-6"	18'-10"	16'-6"	13'-11"
	16		38'-4"	30'-5"	26'-7"	23'-9"	20'-9"	17'-6"	21'-7"	18'-10"	15'-11"	20'-0"	17'-6"	14'-9"	18'-10"	16'-6"	13'-11"	17'-11"	15'-8"	13'-2"	17'-2"	15'-0"	12'-7"
	24		33'-6"	26'-7"	23'-3"	20'-9"	18'-1"	15'-3"	18'-10"	16'-6"	13'-11"	16'-9"	15'-3"	12'-11"	15'-4"	14'-5"	12'-2"	15'-8"	13'-8"	11'-6"	15'-0"	13'-1"	11'-0"
800S162-33 ¹	12	33	45'-3"	35'-11"	31'-4"	28'-0"	24'-6"	20'-8"	25'-6"	22'-3"	18'-9"	23'-8"	20'-8"	17'-5"	22'-3"	19'-5"	16'-5"	21'-2"	18'-6"	15'-7"	20'-3"	17'-8"	14'-11"
	16		41'-1"	32'-7"	28'-6"	25'-3"	22'-3"	18'-9"	23'-2"	20'-3"	17'-1"	21'-6"	18'-9"	15'-10"	20'-3"	17'-8"	14'-11"	19'-2"	16'-9"	14'-2"	18'-4"	16'-0"	13'-6"
	24		35'-11"	28'-6"	24'-11"	22'-6"	19'-5"	16'-5"	20'-3"	17'-8"	14'-11"	18'-9"	16'-5"	13'-10"	17'-8"	15'-5"	13'-0"	16'-9"	14'-8"	12'-4"	16'-0"	14'-0"	11'-10"
800S162-43	12	33	50'-1"	39'-9"	34'-9"	31'-1"	27'-2"	22'-11"	28'-3"	24'-8"	20'-10"	26'-2"	22'-11"	19'-4"	24'-8"	21'-6"	18'-2"	23'-5"	20'-5"	17'-3"	22'-5"	19'-7"	16'-6"
	16		45'-6"	36'-2"	31'-7"	28'-3"	24'-8"	20'-10"	25'-8"	22'-5"	18'-11"	23'-10"	20'-10"	17'-6"	22'-5"	19'-7"	16'-6"	21'-3"	18'-7"	15'-8"	20'-4"	17'-9"	15'-0"
	24		39'-9"	31'-7"	27'-7"	24'-8"	21'-6"	18'-2"	22'-5"	19'-7"	16'-6"	20'-10"	18'-2"	15'-4"	19'-7"	17'-1"	14'-5"	18'-7"	16'-3"	13'-8"	17'-9"	15'-6"	13'-1"
800S162-54	12	50	52'-11"	42'-0"	36'-8"	32'-10"	28'-8"	24'-2"	29'-10"	26'-1"	22'-0"	27'-8"	24'-2"	20'-5"	26'-1"	22'-9"	19'-2"	24'-9"	21'-7"	18'-3"	23'-8"	20'-8"	17'-5"
	16		48'-1"	38'-2"	33'-4"	29'-10"	26'-1"	22'-0"	27'-1"	23'-8"	19'-11"	25'-2"	22'-0"	18'-6"	23'-8"	20'-8"	17'-5"	22'-6"	19'-8"	16'-7"	21'-6"	18'-9"	15'-10"
	24		42'-0"	33'-4"	29'-2"	26'-1"	22'-9"	19'-2"	23'-8"	20'-8"	17'-5"	22'-0"	19'-2"	16'-2"	20'-8"	18'-1"	15'-3"	19'-8"	17'-2"	14'-6"	18'-9"	16'-5"	13'-10"
800S162-68	12	50	41'-3"	32'-9"	28'-7"	25'-7"	22'-4"	18'-10"	23'-3"	20'-4"	17'-2"	21'-5"	18'-10"	15'-11"	19'-6"	17'-9"	15'-0"	18'-1"	16'-10"	14'-3"	16'-11"	16'-1"	13'-7"
	16		37'-6"	29'-9"	26'-0"	23'-3"	20'-4"	17'-2"	20'-9"	18'-5"	15'-7"	18'-6"	17'-2"	14'-5"	16'-11"	16'-1"	13'-7"	15'-8"	15'-4"	12'-11"	14'-8"	14'-8"	12'-4"
	24		32'-9"	26'-0"	22'-9"	19'-6"	17'-9"	15'-0"	16'-11"	16'-1"	13'-7"	15'-2"	15'-0"	12'-7"	13'-10"	13'-10"	11'-11"	12'-9"	12'-9"	12'-0"	12'-0"	12'-0"	10'-9"
800S162-97	12	50	44'-4"	35'-2"	30'-9"	27'-6"	24'-0"	20'-3"	24'-11"	21'-10"	18'-5"	23'-2"	20'-3"	17'-1"	21'-10"	19'-1"	16'-1"	20'-9"	18'-1"	15'-3"	19'-10"	17'-4"	14'-7"
	16		40'-3"	32'-0"	27'-11"	24'-11"	21'-10"	18'-5"	22'-8"	19'-10"	16'-8"	21'-1"	18'-5"	15'-6"	19'-10"	17'-4"	14'-7"	18'-6"	16'-5"	13'-10"	17'-4"	15'-9"	13'-3"
	24		35'-2"	27'-11"	24'-5"	21'-10"	19'-1"	16'-1"	19'-10"	17'-4"	14'-7"	17'-10"	16'-1"	13'-7"	16'-4"	15'-1"	12'-9"	15'-1"	14'-4"	12'-1"	14'-2"	13'-9"	11'-7"
800S162-118	12	50	44'-4"	35'-2"	30'-9"	27'-6"	24'-0"	20'-3"	24'-11"	21'-10"	18'-5"	23'-2"	20'-3"	17'-1"	21'-10"	19'-1"	16'-1"	20'-9"	18'-1"	15'-3"	19'-10"	17'-4"	14'-7"
	16		40'-3"	32'-0"	27'-11"	24'-11"	21'-10"	18'-5"	22'-8"	19'-10"	16'-8"	21'-1"	18'-5"	15'-6"	19'-10"	17'-4"	14'-7"	18'-10"	16'-5"	13'-10"	18'-0"	15'-9"	13'-3"
	24		35'-2"	27'-11"	24'-5"	21'-10"	19'-1"	16'-1"	19'-10"	17'-4"	14'-7"	18'-5"	16'-1"	13'-7"	17'-4"	15'-1"	12'-9"	16'-5"	14'-4"	12'-1"	15'-9"	13'-9"	11'-7"
800S200-33 ¹	12	33	47'-7"	37'-9"	33'-0"	29'-6"	25'-9"	21'-9"	26'-9"	23'-5"	19'-9"	24'-10"	21'-9"	18'-4"	23'-5"	20'-5"	17'-3"	22'-3"	19'-5"	16'-4"	21'-3"	18'-7"	15'-8"
	16		43'-2"	34'-4"	29'-11"	26'-9"	23'-5"	19'-9"	24'-4"	21'-3"	17'-11"	22'-7"	19'-9"	16'-8"	21'-3"	18'-7"	15'-8"	20'-2"	17'-8"	14'-11"	19'-4"	16'-10"	14'-3"
	24		37'-9"	29'-11"	26'-2"	23'-5"	20'-5"	17'-3"	21'-3"	18'-7"	15'-8"	19'-9"	17'-3"	14'-6"	18'-7"	16'-3"	13'-8"	17'-8"	15'-5"	13'-0"	16'-10"	14'-9"	12'-5"
800S200-43	12	33	52'-10"	41'-11"	36'-7"	32'-9"	28'-7"	24'-1"	29'-9"	26'-0"	21'-11"	27'-7"	24'-1"	20'-4"	26'-0"	22'-8"	19'-2"	24'-8"	21'-7"	18'-2"	23'-7"	20'-7"	17'-5"
	16		48'-0"	38'-1"	33'-3"	29'-9"	26'-0"	21'-11"	27'-0"	23'-7"	19'-11"	25'-1"	21'-11"	18'-6"	23'-7"	20'-7"	17'-5"	22'-5"	19'-7"	16'-6"	21'-5"	18'-9"	15'-10"
	24		41'-11"	33'-3"	29'-1"	26'-0"	22'-8"	19'-2"	23'-7"	20'-7"	17'-5"	21'-11"	19'-2"	16'-2"	20'-7"	18'-0"	15'-2"	19'-7"	17'-1"	14'-5"	18'-9"	16'-4"	13'-10"
800S200-54	12	33	55'-10"	44'-4"	38'-9"	34'-7"	30'-3"	25'-6"	31'-5"	27'-6"	23'-2"	29'-2"	25'-6"	21'-6"	27'-6"	24'-0"	20'-3"	26'-1"	22'-10"	19'-3"	25'-0"	21'-10"	18'-5"
	16		50'-9"	40'-3"	35'-2"	31'-5"	27'-6"	23'-2"	28'-7"	25'-0"	21'-1"	26'-6"	23'-2"	19'-7"	25'-0"	21'-10"	18'-5"	23'-9"	20'-9"	17'-6"	22'-8"	19'-10"	16'-9"
	24		44'-4"	35'-2"	30'-9"	27'-6"	24'-0"	20'-3"	25'-0"	21'-10"	18'-5"	23'-2"	20'-3"	17'-1"	21'-10"	19'-1"	16'-1"	20'-9"	18'-1"	15'-3"	19'-10"	17'-4"	14'-7"
800S200-54	12	50	43'-3"	34'-4"																			

Curtain Wall – Limiting Wall Heights (Continued)

Stud Member	Spacing	Fy (ksi)	5 psf			15 psf			20 psf			25 psf			30 psf			
			L/120	L/240	L/360	L/120	L/240	L/360	L/120	L/240	L/360	L/120	L/240	L/360	L/120	L/240	L/360	L/120
800S250-54	12	50	37'-8"	29'-11"	26'-2"	23'-4"	20'-5"	17'-3"	20'-6"	18'-6"	15'-8"	18'-4"	17'-3"	14'-6"	16'-8"	16'-2"	13'-8"	15'-6"
	16		34'-3"	27'-2"	23'-9"	20'-6"	18'-6"	15'-8"	17'-9"	16'-10"	14'-3"	15'-10"	15'-8"	13'-2"	14'-6"	14'-6"	12'-5"	13'-5"
	24		28'-11"	23'-9"	20'-9"	16'-8"	16'-2"	13'-8"	14'-6"	14'-6"	12'-5"	12'-11"	12'-11"	11'-6"	11'-10"	11'-10"	10'-10"	10'-11"
800S250-68	12	50	40'-5"	32'-1"	28'-0"	25'-1"	21'-11"	18'-5"	22'-9"	19'-11"	16'-9"	20'-10"	18'-5"	15'-7"	19'-1"	17'-4"	14'-8"	17'-8"
	16		36'-9"	29'-2"	25'-6"	22'-9"	19'-11"	16'-9"	20'-2"	18'-1"	15'-3"	18'-1"	16'-9"	14'-2"	16'-6"	15'-9"	13'-4"	15'-3"
	24		32'-1"	25'-6"	22'-3"	19'-1"	17'-4"	14'-8"	16'-6"	15'-9"	13'-4"	14'-9"	14'-8"	12'-4"	13'-6"	13'-6"	11'-8"	12'-6"
800S250-97	12	50	40'-5"	32'-1"	28'-0"	25'-1"	21'-11"	18'-5"	22'-9"	19'-11"	16'-9"	21'-2"	18'-5"	15'-7"	19'-11"	17'-4"	14'-8"	18'-11"
	16		36'-9"	29'-2"	25'-6"	22'-9"	19'-11"	16'-9"	20'-8"	18'-1"	15'-3"	19'-2"	16'-9"	14'-2"	18'-1"	15'-9"	13'-4"	17'-2"
	24		32'-1"	25'-6"	22'-3"	19'-11"	17'-4"	14'-8"	18'-1"	15'-9"	13'-4"	16'-9"	14'-8"	12'-4"	15'-9"	13'-9"	11'-8"	14'-9"
800S250-118	12	50	43'-4"	34'-4"	30'-0"	26'-10"	23'-5"	19'-9"	24'-5"	21'-4"	18'-0"	22'-8"	19'-9"	16'-8"	21'-4"	18'-7"	15'-8"	20'-3"
	16		39'-4"	31'-3"	27'-3"	24'-5"	21'-4"	18'-0"	22'-2"	19'-4"	16'-4"	20'-7"	18'-0"	15'-2"	19'-4"	16'-11"	14'-3"	18'-5"
	24		34'-4"	27'-3"	23'-10"	21'-4"	18'-7"	15'-8"	19'-4"	16'-11"	14'-3"	18'-0"	15'-8"	13'-3"	16'-11"	14'-9"	12'-5"	16'-1"
800S300-54	12	50	47'-11"	38'-0"	33'-3"	29'-8"	25'-11"	21'-10"	27'-0"	23'-7"	19'-10"	25'-0"	21'-10"	18'-5"	23'-7"	20'-7"	17'-4"	22'-5"
	16		43'-6"	34'-6"	30'-2"	27'-0"	23'-7"	19'-10"	24'-6"	21'-5"	18'-1"	22'-9"	19'-10"	16'-9"	21'-8"	18'-5"	15'-8"	20'-3"
	24		38'-0"	30'-2"	26'-4"	23'-7"	20'-7"	17'-4"	21'-5"	18'-8"	15'-9"	19'-10"	17'-4"	14'-8"	18'-8"	16'-4"	13'-9"	17'-9"
800S300-68	12	50	36'-1"	28'-8"	25'-0"	22'-4"	19'-7"	16'-6"	19'-5"	17'-9"	15'-0"	17'-5"	16'-6"	13'-11"	15'-10"	15'-6"	13'-1"	14'-8"
	16		32'-9"	26'-0"	22'-9"	19'-5"	17'-9"	15'-0"	16'-10"	16'-2"	13'-7"	15'-1"	15'-0"	12'-8"	13'-9"	13'-9"	11'-11"	12'-9"
	24		27'-6"	22'-9"	19'-10"	15'-10"	15'-6"	13'-1"	13'-9"	13'-9"	11'-11"	12'-3"	12'-3"	11'-0"	11'-3"	11'-3"	10'-5"	10'-5"
800S300-97	12	50	39'-4"	31'-2"	27'-3"	24'-4"	21'-3"	17'-11"	22'-2"	19'-4"	16'-4"	20'-7"	17'-11"	15'-2"	19'-0"	16'-11"	14'-3"	17'-7"
	16		35'-9"	28'-4"	24'-9"	22'-2"	19'-4"	16'-4"	20'-1"	17'-7"	14'-10"	18'-1"	16'-4"	13'-9"	16'-6"	15'-4"	12'-11"	15'-3"
	24		31'-2"	24'-9"	21'-8"	19'-0"	16'-11"	14'-3"	16'-6"	15'-4"	12'-11"	14'-9"	14'-3"	12'-0"	13'-5"	13'-5"	11'-4"	12'-5"
800S300-118	12	50	42'-2"	33'-6"	29'-3"	26'-2"	22'-10"	19'-3"	23'-9"	20'-9"	17'-6"	22'-1"	19'-3"	16'-3"	20'-9"	18'-1"	15'-3"	19'-8"
	16		38'-4"	30'-5"	26'-7"	23'-9"	20'-9"	17'-6"	21'-7"	18'-10"	15'-11"	20'-0"	17'-6"	14'-9"	18'-9"	16'-6"	13'-11"	17'-4"
	24		33'-6"	26'-7"	23'-3"	20'-9"	18'-1"	15'-3"	18'-9"	16'-6"	13'-11"	16'-9"	15'-3"	12'-11"	15'-4"	14'-5"	12'-2"	14'-2"
800S350-54	12	50	42'-2"	33'-6"	29'-3"	26'-2"	22'-10"	19'-3"	23'-9"	20'-9"	17'-6"	22'-1"	19'-3"	16'-3"	20'-9"	18'-1"	15'-3"	19'-8"
	16		38'-4"	30'-5"	26'-7"	23'-9"	20'-9"	17'-6"	21'-7"	18'-10"	15'-11"	20'-0"	17'-6"	14'-9"	18'-10"	16'-6"	13'-11"	17'-11"
	24		33'-6"	26'-7"	23'-3"	20'-9"	18'-1"	15'-3"	18'-10"	16'-6"	13'-11"	17'-6"	15'-3"	12'-11"	16'-6"	14'-5"	12'-2"	15'-8"
800S350-68	12	50	45'-3"	35'-11"	31'-4"	28'-0"	24'-6"	20'-8"	25'-6"	22'-3"	18'-9"	23'-8"	20'-8"	17'-5"	22'-3"	19'-5"	16'-5"	21'-2"
	16		41'-1"	32'-7"	28'-6"	25'-6"	22'-3"	18'-9"	23'-2"	20'-3"	17'-1"	21'-6"	18'-9"	15'-10"	20'-3"	17'-8"	14'-11"	19'-2"
	24		35'-11"	28'-6"	24'-11"	22'-3"	19'-5"	16'-5"	20'-3"	17'-8"	14'-11"	18'-9"	16'-5"	13'-10"	17'-8"	15'-5"	13'-0"	16'-9"
800S350-97	12	50	50'-1"	39'-9"	34'-9"	31'-1"	27'-2"	22'-11"	28'-3"	24'-8"	20'-10"	26'-2"	22'-11"	19'-4"	24'-8"	21'-6"	18'-2"	23'-5"
	16		45'-6"	36'-2"	31'-7"	28'-3"	24'-8"	20'-10"	25'-8"	22'-5"	18'-11"	23'-10"	20'-10"	17'-6"	22'-5"	19'-7"	16'-6"	21'-3"
	24		39'-9"	31'-7"	27'-7"	24'-8"	21'-6"	18'-2"	22'-5"	19'-7"	16'-6"	20'-10"	18'-2"	15'-4"	19'-7"	17'-1"	14'-5"	18'-7"
800S350-118	12	50	52'-11"	42'-0"	36'-8"	32'-10"	28'-8"	24'-2"	29'-10"	26'-1"	22'-0"	27'-8"	24'-2"	20'-5"	26'-1"	22'-9"	19'-2"	24'-9"
	16		48'-1"	38'-2"	33'-4"	29'-10"	26'-1"	22'-0"	27'-1"	23'-8"	19'-11"	25'-2"	22'-0"	18'-6"	23'-8"	20'-8"	17'-5"	22'-6"
	24		42'-0"	33'-4"	29'-2"	26'-1"	22'-9"	19'-2"	23'-8"	20'-8"	17'-5"	22'-0"	19'-2"	16'-2"	20'-8"	18'-1"	15'-3"	19'-8"