

Product	Page No.
Panel Information	
IC72-Panel Profiles.....	PIC-2
Panel Overview	PIC-2
Flashing Profiles	
Eave	PIC-3
IC72-Panel Sculptured Gutter	PIC-3
IC72-Panel Sculptured Gutter End	PIC-3
Universal Gutter/Downspout Strap	PIC-3
4" x 3 1/2" Downspout.....	PIC-3
4" x 3 1/2" 90° Elbow.....	PIC-3
Downspout Bracket	PIC-3
Valley	PIC-3
IC72-Panel Rake	PIC-3
IC72-Panel Sculptured Rake.....	PIC-3
Sculptured Rake End.....	PIC-3
Rakewall	PIC-3
Pitch Break	PIC-3
Peak	PIC-3
Counter Flashing	PIC-3
Reglet Flashing.....	PIC-4
Sculptured High Side Eave.....	PIC-4
20" Ridge/Hip Cover.....	PIC-4
Universal Ridge	PIC-4
Coping	PIC-4
Gravel Stop.....	PIC-4
Outside Corner	PIC-4
Inside Corner	PIC-4
IC72-Panel Outside Corner	PIC-4
IC72-Panel Inside Corner.....	PIC-4
1.5" Sill/Head.....	PIC-4
1.5" Sill to Soffit	PIC-4
IC72-Panel C-Closure	PIC-4
IC72-Panel Jamb.....	PIC-4
Head Channel.....	PIC-4
Head/Jamb Cover.....	PIC-5
Base	PIC-5
IC72-Panel Gutter Hanger.....	PIC-5
Accessory Profiles	
IC72-Panel Light Transmitting Panel	PIC-5
IC72-Panel Closures	PIC-5
Universal Closure	PIC-5
Tube Sealant	PIC-5
Tape Sealant.....	PIC-5
Rubber Roof Jack.....	PIC-5
Retro Roof Jack.....	PIC-5
Rubber Roof Flash Kit	PIC-5
Touch-Up Paint.....	PIC-5
Testing Information	
Section Properties and General Information	PIC-6
Design/Installation Considerations	
Fastener Installation Technique.....	PIC-7
Condition of Substructure.....	PIC-7
Roof Panel Fastening Pattern	PIC-8
Wall Panel Fastening Pattern	PIC-8

Product	Page No.
Detail Conditions	
Eave Detail	PIC-9
Sculptured Gutter Detail	PIC-9
Valley Detail.....	PIC-10
Sculptured Rake Detail.....	PIC-10
Rakewall Detail.....	PIC-11
Endwall Detail.....	PIC-11
Peak Detail	PIC-12
Ridge/Hip Detail.....	PIC-12
Universal Ridge Detail.....	PIC-13
Gravel Stop Detail	PIC-13
Outside Corner Detail.....	PIC-14
Inside Corner Detail.....	PIC-14
Jamb Detail.....	PIC-15
Head Detail.....	PIC-15
Base Detail	PIC-16
Notes	
Notes	PIC-16

ROOF PROFILE

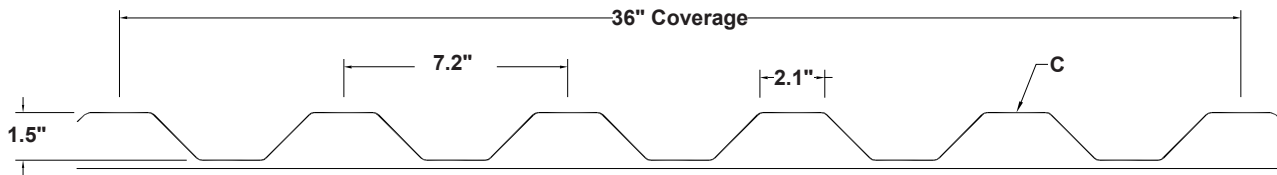

WALL PROFILE

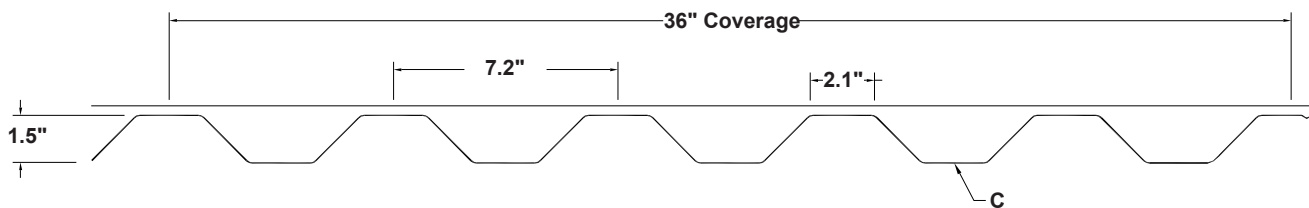

SLOPE

The minimum recommended slope for IC72-Panel roof panel is 1:12.

SUBSTRATE

IC72-Panel is designed to be utilized over open structural framing, but can easily be used with a solid substrate. For solid substrate applications, the recommended substrate is 5/8" plywood with a 30 pound felt moisture barrier. To avoid panel distortion, use a properly aligned and uniform substructure.

COVERAGE

IC72-Panel has a coverage of 36" with a 1 1/2" rib height.

LENGTH

Lengths under 5'-0" are available with some cutting restrictions. Maximum recommended panel length is 45'-0". Longer panels require additional consideration in packaging, shipping and erection. Please consult your Metal Sales branch for recommendations (see PGI-2 and PGI-3 for locations).

AVAILABILITY

26, 24 and 22 Gauge (minimum quantities may apply)

APPLICATION

Commercial and Industrial Panel

FASTENING SYSTEM

Direct Fastened (exposed)

FASTENERS

The fastener selection guide should be consulted for choosing proper fasteners for specific applications. Quantity and type of fastener must meet necessary loading and code requirements (see PGI-12 through PGI-14).

MATERIALS

26, 24 and 22 gauge steel: Grade 50 per ASTM A 792

FINISH

- ▶ *Acrylic-Coated Galvalume® (ACG), AZ55 per ASTM A 792
- ▶ Prepainted Galvalume®, AZ50 per ASTM A 792
- ▶ **PVDF
 - * Differential appearance of Acrylic Coated Galvalume® roofing materials is not a cause for rejection.
 - ** Meets both Kynar 500® and Hylar 5000® specifications.

EAVE

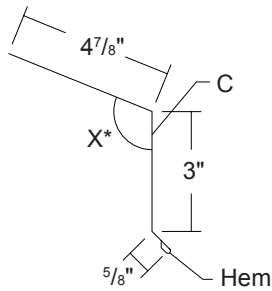

Length 10'-2" - *Specify Slope Angle

IC72-PANEL SCULPTURED GUTTER

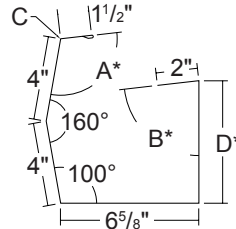

Lengths 10'-2" and 20'-3"
*Specify Slope Angle For A and B, and Length for D.

IC72-PANEL SCULPTURED GUTTER END

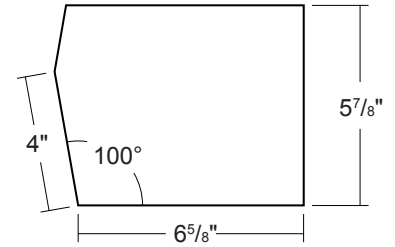

UNIVERSAL GUTTER/ DOWNSPOUT STRAP

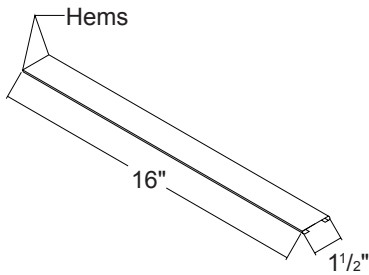

4" x 3 1/2" DOWNSPOUT

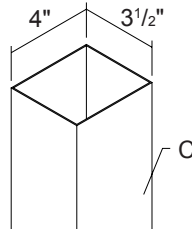

Lengths 10'-2" and 20'-3"
(6" x 4" is also available)

4" x 3 1/2" 95° ELBOW

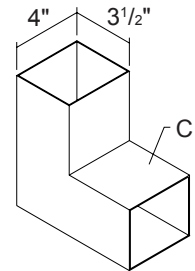

(6" x 4" is also available)

DOWNSPOUT BRACKET

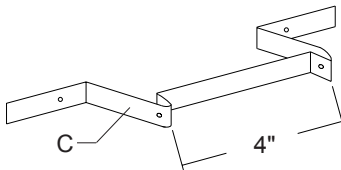

(6" is also available)

VALLEY

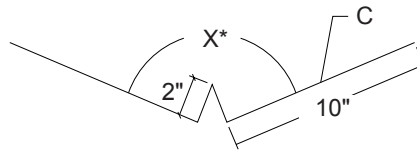

Lengths 10'-2" and 20'-3"
*Specify Slope Angle

IC72-PANEL RAKE

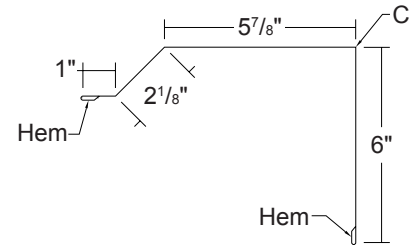

Lengths 10'-2" and 20'-3"

IC72-PANEL SCULPTURED RAKE

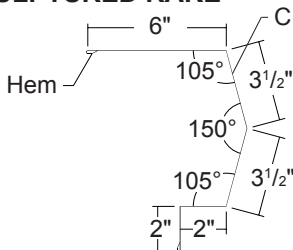

Lengths 10'-2" and 20'-3"

SCULPTURED RAKE END

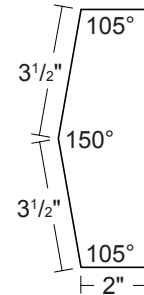

RAKEWALL

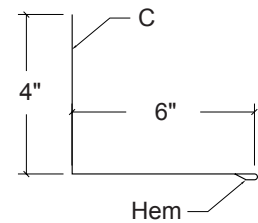

Length 10'-2"

PITCH BREAK

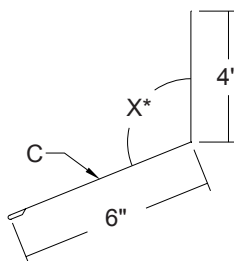

Length 10'-2" - *Specify Slope Angle

PEAK

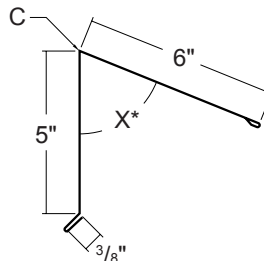

Lengths 10'-2" and 20'-3"
*Specify Slope Angle

COUNTER FLASHING

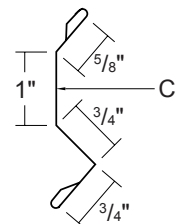

Length 10'-2"

IC72-PANEL FLASHING PROFILES (CONT.)

REGLET FLASHING

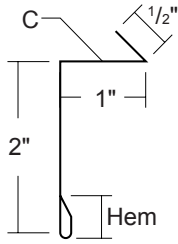

Length 10'-2"

SCULPTURED HIGH SIDE EAVE

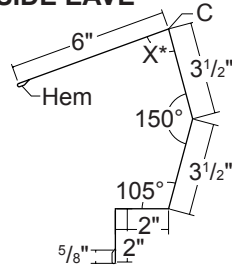

Lengths 10'-2" and 20'-3"
*Specify Slope Angle

20" RIDGE/HIP COVER

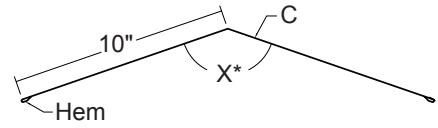

Lengths 10'-2" and 20'-3"
*Specify Slope Angle

UNIVERSAL RIDGE

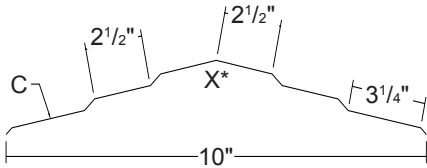

Length 10'-2" - *Specify Slope Angle

COPING

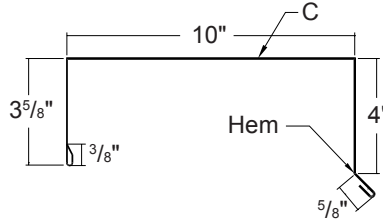

Lengths 10'-2" and 20'-3"

GRAVEL STOP

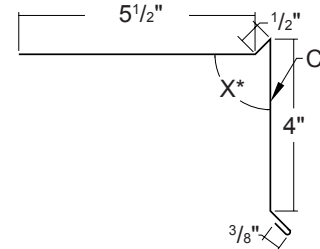

Lengths 10'-2" and 20'-3"
*Specify Slope Angle

OUTSIDE CORNER

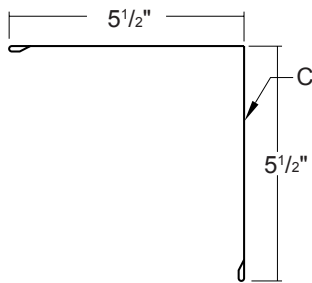

Lengths 10'-2" and 20'-3"

INSIDE CORNER

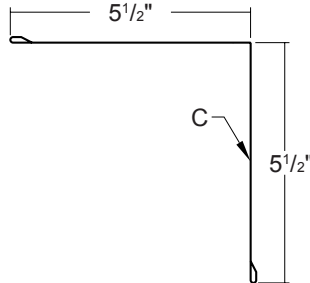

Lengths 10'-2" and 20'-3"

IC72-PANEL OUTSIDE CORNER

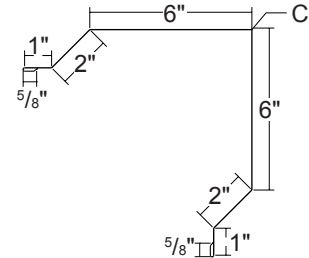

Lengths 10'-2", 14'-2" and 20'-3"

IC72-PANEL INSIDE CORNER

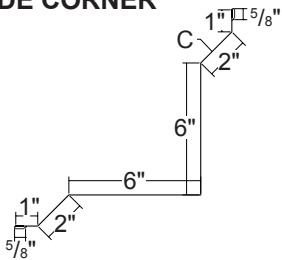

Lengths 10'-2", 14'-2" and 20'-3"

1.5" SILL/HEAD

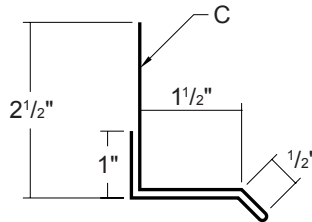

Length 10'-2"

1.5" SILL TO SOFFIT

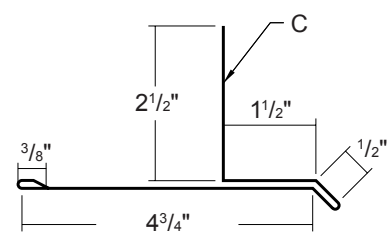

Length 10'-2"

IC72-PANEL C-CLOSURE

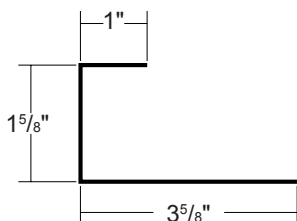

Length 10'-2"

IC72-PANEL JAMB

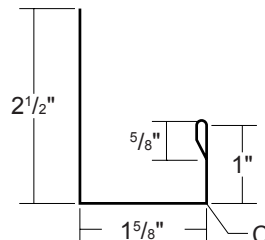

Lengths 7'-3", 10'-2" and 14'-2"

HEAD CHANNEL

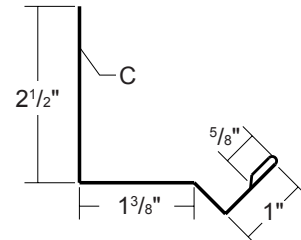

Length 10'-2"

HEAD/JAMB COVER

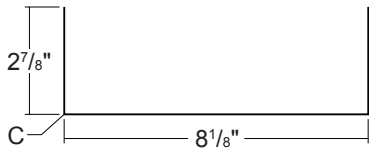

Lengths 10'-2" and 14'-2"

BASE

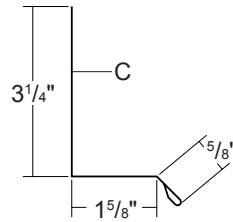

Length 10'-2"

IC72-PANEL GUTTER HANGER

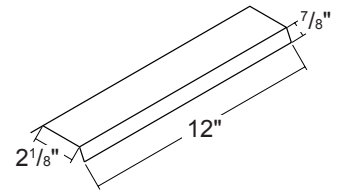

Length 1'-0"

IC72-PANEL

ACCESSORY PROFILES

IC72-PANEL LIGHT TRANSMITTING PANEL

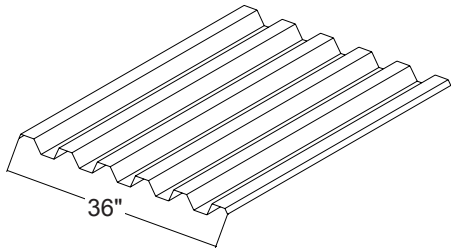

IC72-PANEL CLOSURES



Inside and Outside Polyethylene Foam

UNIVERSAL CLOSURE

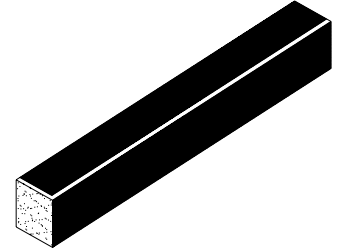

1" x 1 1/2" x 50' Polyethylene Foam
1" x 1 1/2" x 10' Polyethylene Foam

TUBE SEALANT

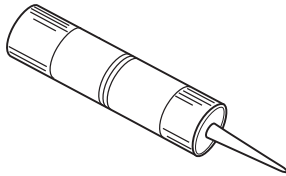

10.3 oz. Cartridge Urethane

TAPE SEALANT

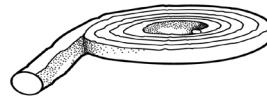

3/8" X 3/32" X 50'
Single Bead Tape Sealant
Butyl - Gray

RUBBER ROOF JACK

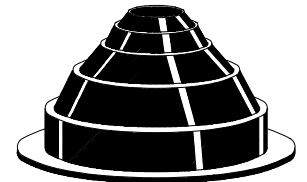

Mini (1/4" to 1 1/8" O.D. Pipe)
#2 (1 3/4" to 3" O.D. Pipe)
#4 (3" to 6" O.D. Pipe)
#6 (6" to 9" O.D. Pipe)
#8 (7" to 13" O.D. Pipe)

RETRO ROOF JACK

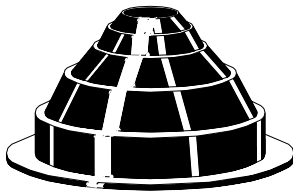

#801_{RETRO} (3/4" to 2 3/4" O.D. Pipe)
#802_{RETRO} (2" to 7 1/4" O.D. Pipe)
#803_{RETRO} (3 1/4" to 10" O.D. Pipe)

RUBBER ROOF FLASH KIT

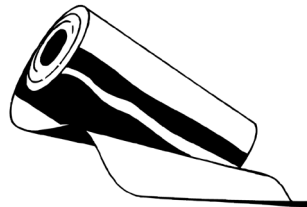

12" x 50'-0" Flash Kit
18" x 50'-0" Flash Kit

TOUCH-UP PAINT

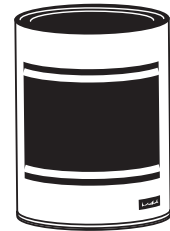

Available in 2 oz Bottles
PVDF / MS Colorfast45®

C- Indicates color side of flashing.

IC72-PANEL SECTION PROPERTIES AND GENERAL INFORMATION

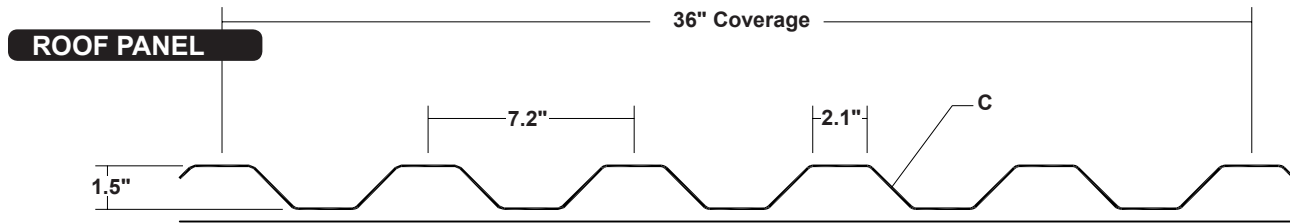

SECTION PROPERTIES								ALLOWABLE UNIFORM LOADS psf (3 or More Equal Spans)											
Ga	Width in	Yield ksi	Weight psf	Top In Compression		Bottom In Compression		Inward Load						Outward Load					
				Ixx in ⁴ /ft	Sxx in ³ /ft	Ixx in ⁴ /ft	Sxx in ³ /ft	5'	6'	7'	8'	9'	10'	5'	6'	7'	8'	9'	10'
26	36	50	0.88	0.0706	0.0817	0.0653	0.0663	58	41	31	24	19	15	70	50	37	29	22	16
24	36	50	1.15	0.1000	0.1208	0.0987	0.1076	97	68	50	39	29	21	108	76	56	42	29	21
22	36	50	1.51	0.1408	0.1757	0.1391	0.1557	142	100	73	54	38	28	160	112	82	55	38	28

- Theoretical section properties have been calculated per AISI 2012 "Specifications for the Design of Cold-formed Steel Structural Members." Ixx and Sxx are effective section properties for deflection and bending.
- Allowable load is calculated in accordance with AISI 2012 specifications considering bending, shear, combined bending and shear and deflection. Allowable load considers the 3 or more equal span condition. Allowable load does not address web crippling, fasteners/support connection or load testing. Panel weight is not considered.
- Deflection consideration is limited by a maximum deflection ratio of L/180 of span.
- Allowable loads do not include a 1/3 stress increase in uplift.

ATTACHMENT DETAIL

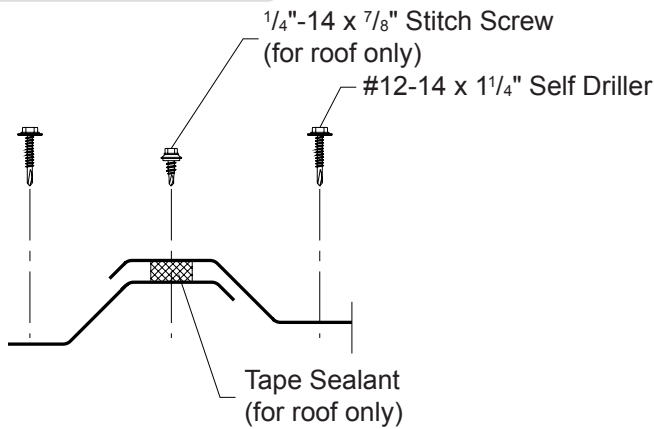

FASTENING PATTERNS

ENDS OF PANEL

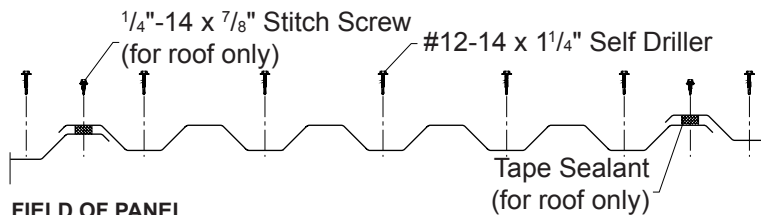

FIELD OF PANEL

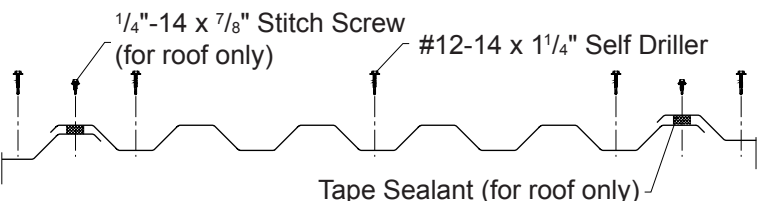

GENERAL INFORMATION

► Slope

The minimum recommended slope for IC72-Panel is 1:12. Metal Sales recommends that in all roof applications sealants be used on all sidelaps with stitch screw 1'-0" on center.

► Substructure

IC72-Panel is designed to be utilized over open structural framing or a solid substrate. To avoid panel distortion use a properly aligned and uniform substructure.

► Coverage

IC72-Panel is available in a 1 1/2" rib height with a 36" width coverage.

► Length

Minimum factory cut length is 5'-0". Maximum recommended panel length is 45'-0". Longer panels require additional consideration in packaging, shipping, and erection. Please consult Metal Sales for recommendations.

► Fasteners

The fastener selection guide should be consulted for choosing the proper fastener for specific applications. Quantity and type of fastener must meet necessary loading and code requirements.

NOTE: All panels are subject to surface distortion due to improperly applied fasteners. Overdriven fasteners will cause stress and induce oil canning across the face of the panel at or near the point of attachment.

► Availability

Finishes: Acrylic-Coated Galvalume® and PVDF
Gauges: 26 ga, 24 ga and 22 ga

FASTENER INSTALLATION TECHNIQUE

Recommended Tool Type - Use depth locating nose or adjustable clutch on screw gun to prevent overdrilling and strip out. **Do not use impact tools or runners.**

Seating the washer - Apply sufficient torque to seat the washer - do not overdrive the fastener.

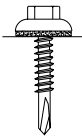
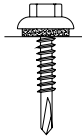
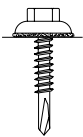
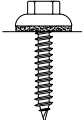
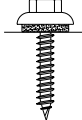
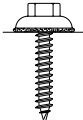
	CORRECT Sealing material slightly visible at edge of metal washer. Assembly is watertight.	TOO LOOSE Sealing material is not visible; not enough compression to seal properly.	TOO TIGHT Metal washer deformed; sealing material pressed beyond washer edge.
SELF DRILLER			
WOODSCREW			

To prevent wobbling - Make sure fastener head is completely engaged in the socket. If the head does not go all the way in the socket - tap the magnet deeper into the socket to allow full head engagement. Metal chips will build up from drilling and should be removed from time to time.

Protect drill point - Push only hard enough on the screw gun to engage clutch. This prevents excess friction and burn out of the drill point. Correct pressure will allow screw to drill and tap without binding.

Drilling through sheet and insulation - Ease up on pressure when drilling through insulation to avoid striking the purlin or girt with the point - apply more pressure after drill point contacts purlin or girt.

Drilling through purlin overlaps - Drilling through lapped purlins requires extra care. Excessive voids between purlins sometimes damages drill points and two self-drillers might be necessary to complete the operation. It is sometimes advantageous to predrill.

CONDITION OF SUBSTRUCTURE

Whether over solid substrate or open structural framing, panel distortion may occur if not applied over properly aligned and uniform substructure.

The installer should check the roof deck for squareness before installing IC72-Panels. Several methods can be used to verify squareness of the structure for proper installation of the panels.

METHOD "A" - One method for checking the roof for squareness is to measure diagonally across one slope of the roof from similar points at the ridge and eave and obtain the same dimension.

METHOD "B" - The 3-4-5 triangle system may also be used. To use this system measure a point from the corner along the edge of the roof at a module of three (3). Measure a point from the same corner along another edge at a module of four (4). Then by measuring diagonally between the two points established, the dimension should be exactly a module of five (5) to have a square corner. Multiple uses of this system may be required to determine building squareness. If the endwall cannot be made square, the roof system cannot be installed as shown in these instructions.

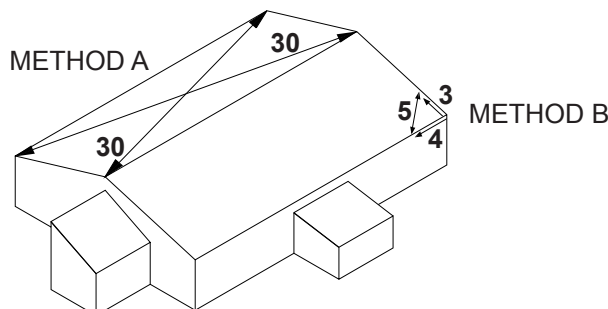

IC72-PANEL DESIGN / INSTALLATION CONSIDERATIONS (CONT.)

ROOF PANEL FASTENING PATTERN

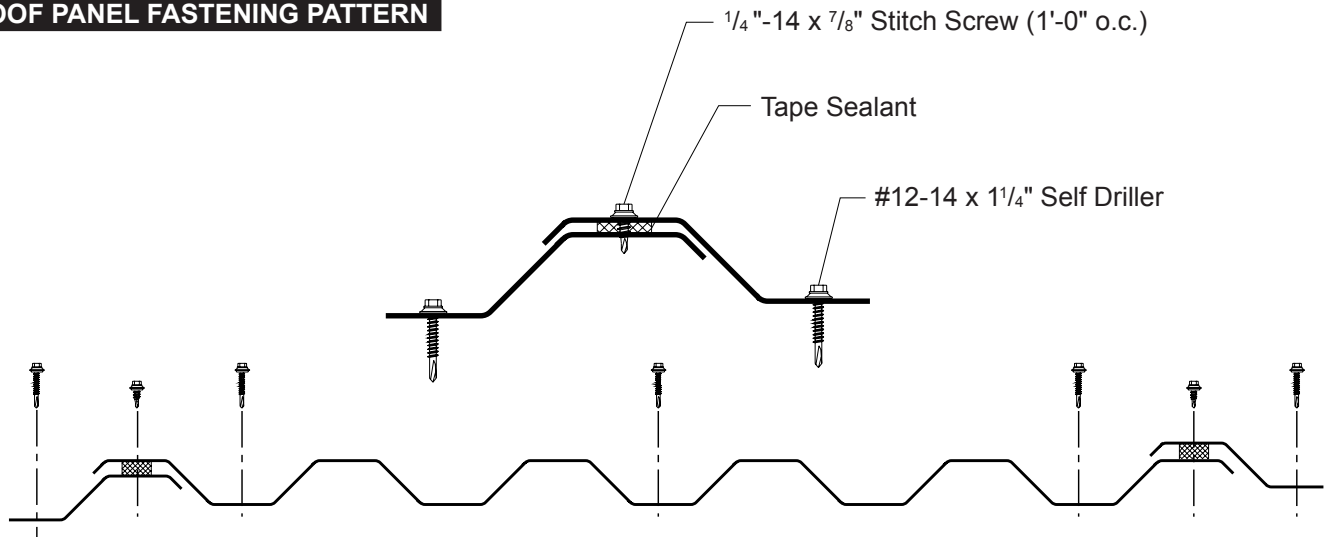

IC72-Panel Fastening Pattern - Interior

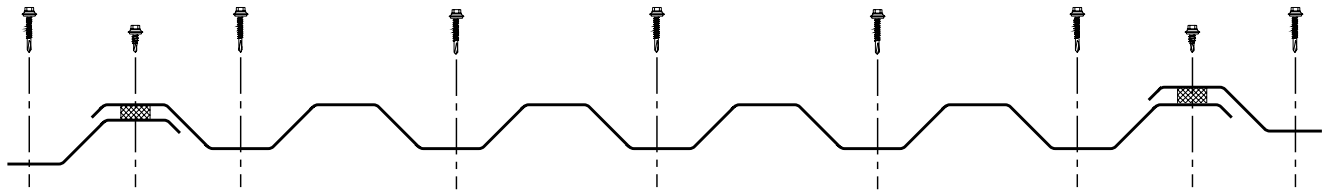

IC72-Panel Fastening Pattern - Ends

WALL PANEL FASTENING PATTERN

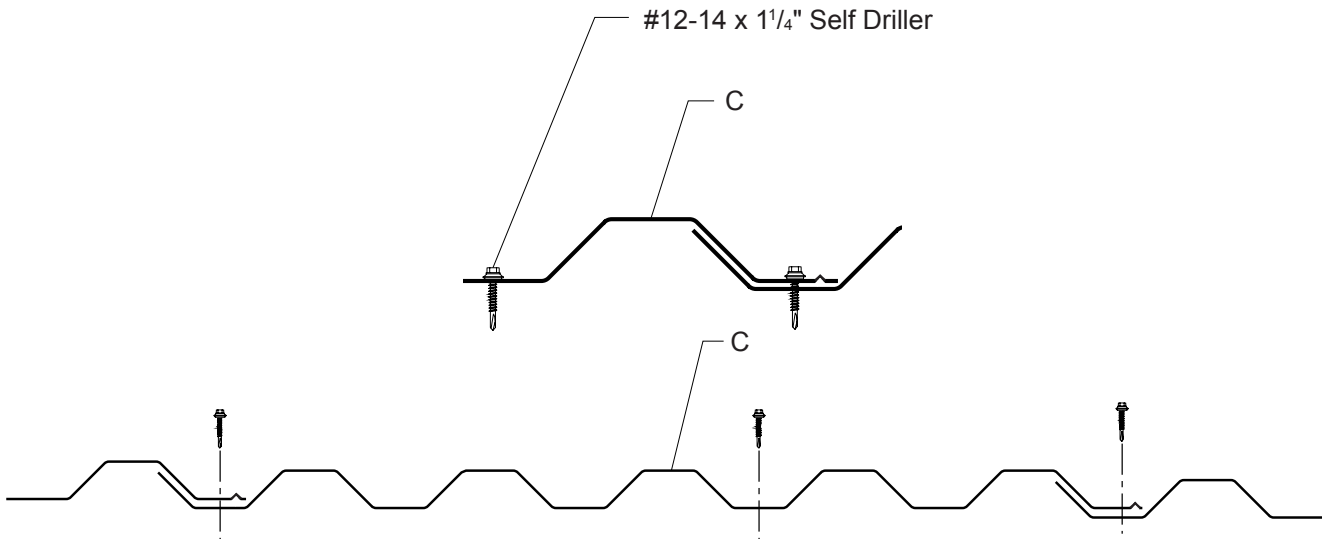

IC72-Panel Fastening Pattern - Interior

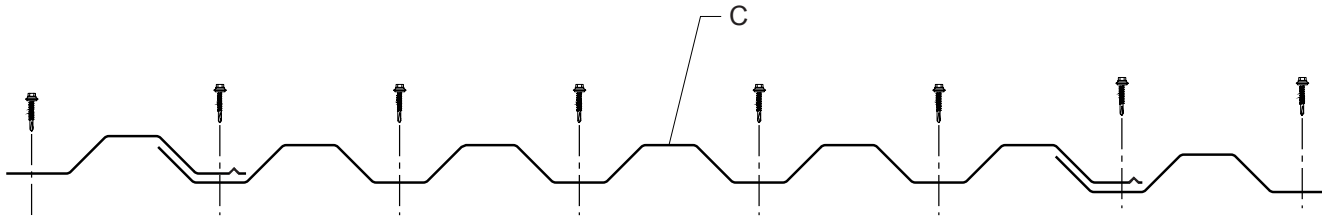

IC72-Panel Fastening Pattern - Ends

IC72-PANEL

EAVE DETAIL

1:12 Minimum
Roof Slope

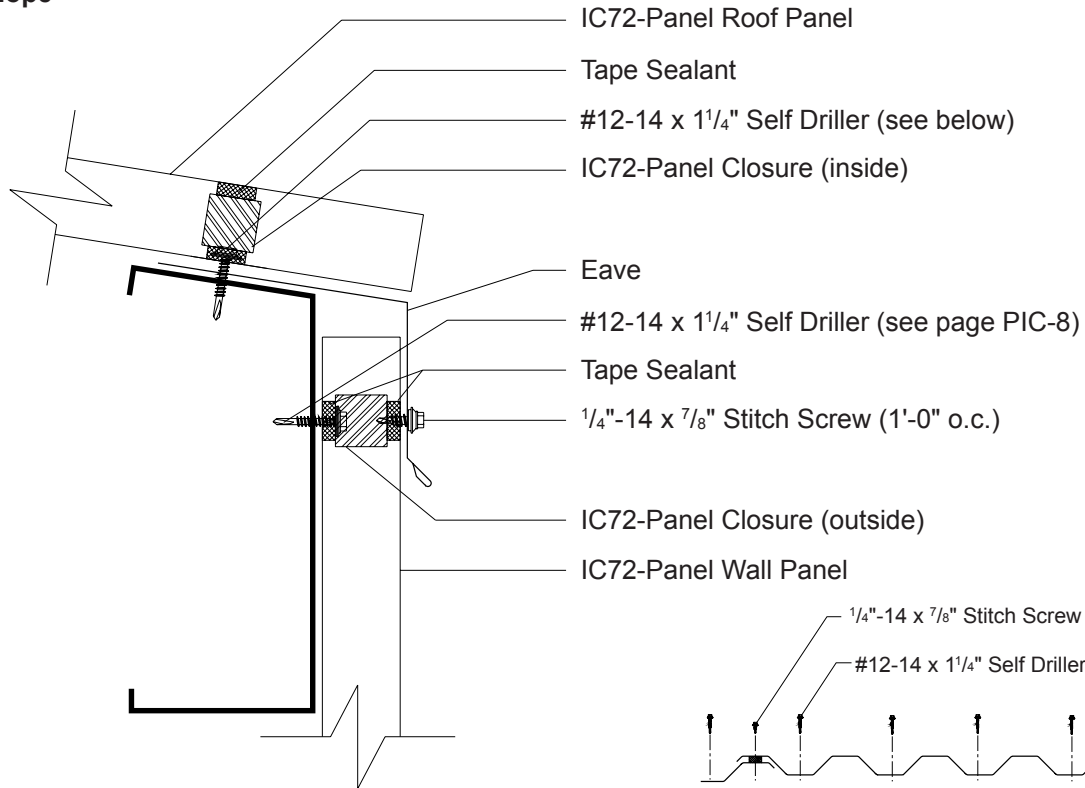

- IC72-PANEL Roof Panel
- Tape Sealant
- #12-14 x 1 1/4" Self Driller (see below)
- IC72-PANEL Closure (inside)
- Eave
- #12-14 x 1 1/4" Self Driller (see page PIC-8)
- Tape Sealant
- 1/4"-14 x 7/8" Stitch Screw (1'-0" o.c.)
- IC72-PANEL Closure (outside)
- IC72-PANEL Wall Panel

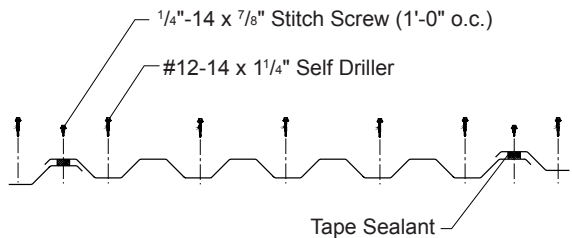

IC72-Panel Roof Fastening Pattern

IC72-PANEL

SCULPTURED GUTTER DETAIL

1:12 Minimum
Roof Slope

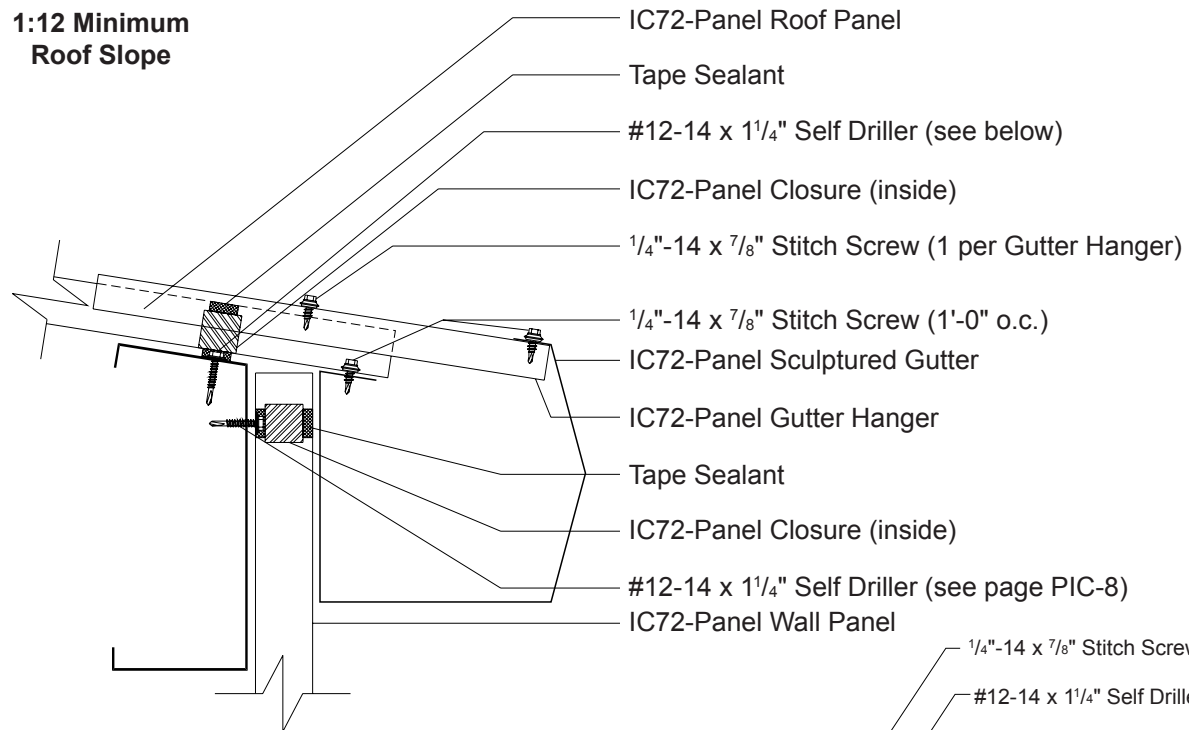

- IC72-PANEL Roof Panel
- Tape Sealant
- #12-14 x 1 1/4" Self Driller (see below)
- IC72-PANEL Closure (inside)
- 1/4"-14 x 7/8" Stitch Screw (1 per Gutter Hanger)
- 1/4"-14 x 7/8" Stitch Screw (1'-0" o.c.)
- IC72-PANEL Sculptured Gutter
- IC72-PANEL Gutter Hanger
- Tape Sealant
- IC72-PANEL Closure (inside)
- #12-14 x 1 1/4" Self Driller (see page PIC-8)
- IC72-PANEL Wall Panel

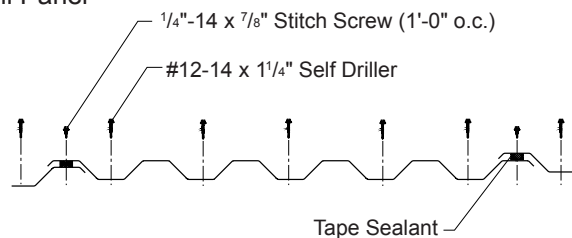

IC72-Panel Roof Fastening Pattern

IC72-PANEL

VALLEY DETAIL

1:12 Minimum
Roof Slope

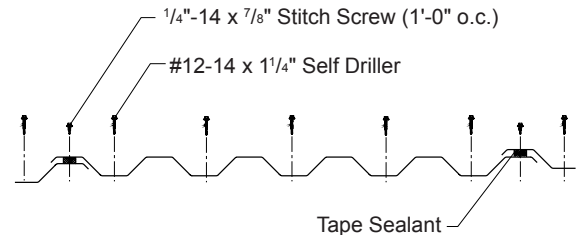
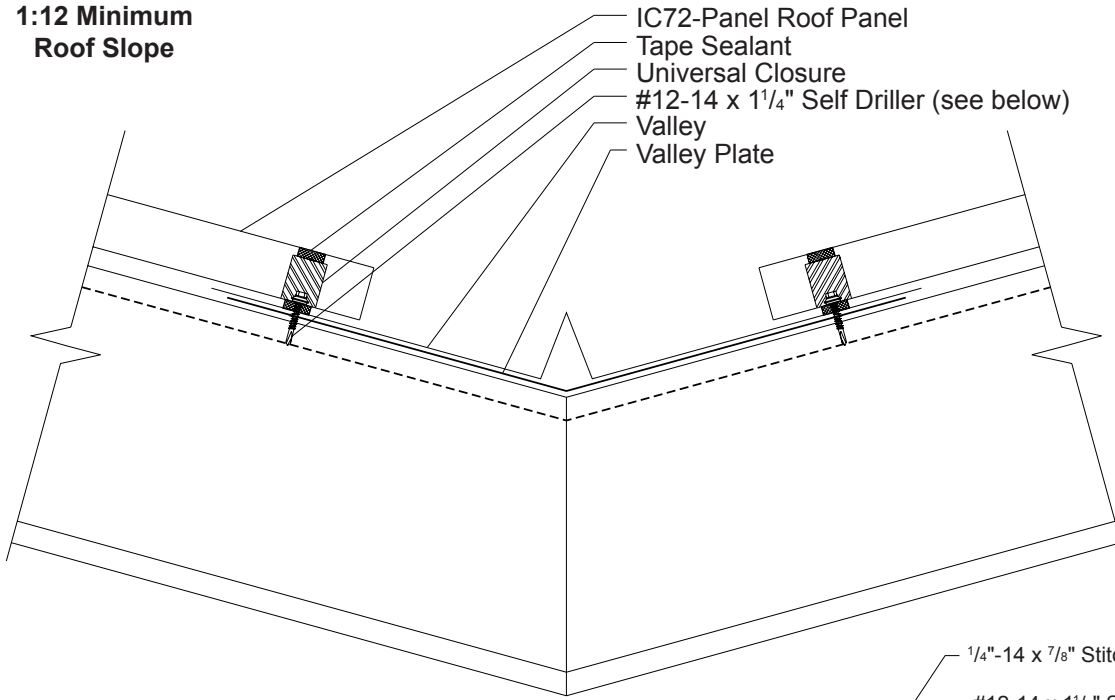

IC72-Panel Roof Fastening Pattern

IC72-PANEL

SCULPTURED RAKE DETAIL

1:12 Minimum
Roof Slope

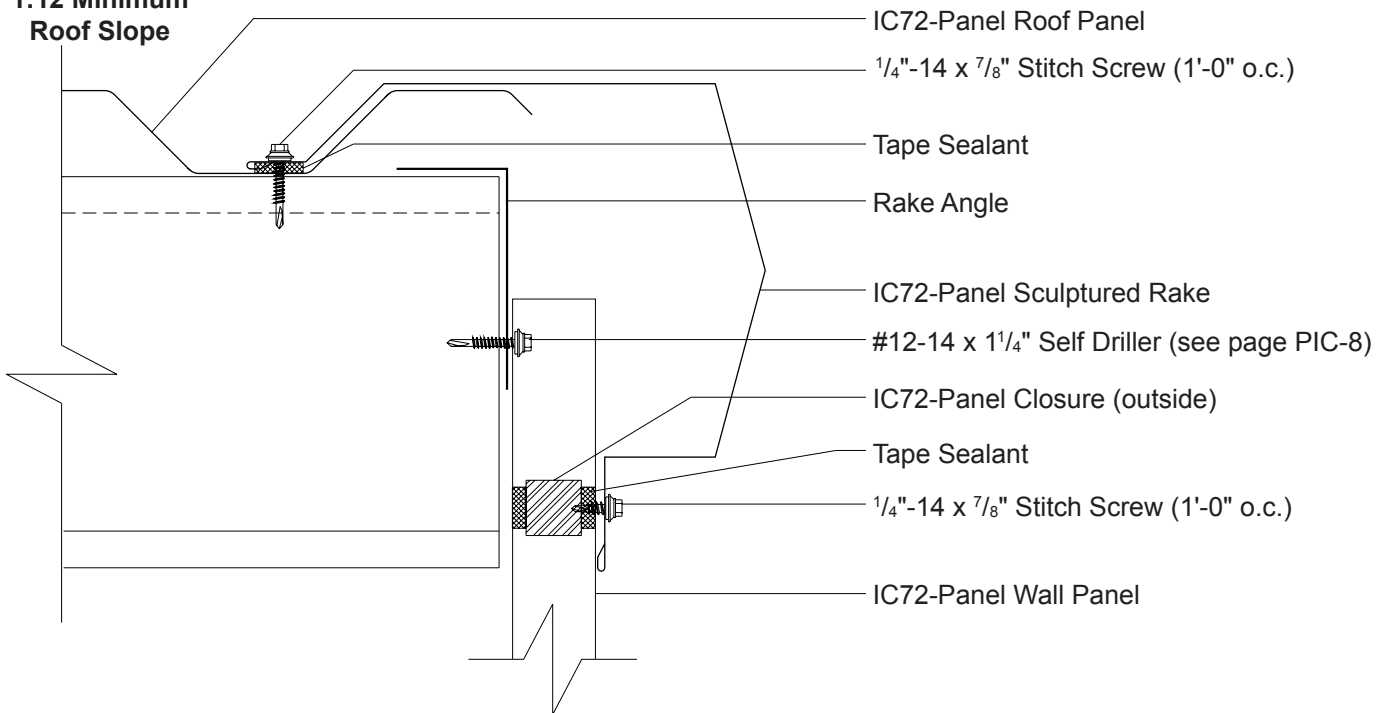

IC72-PANEL

RAKEWALL DETAIL

1:12 Minimum
Roof Slope

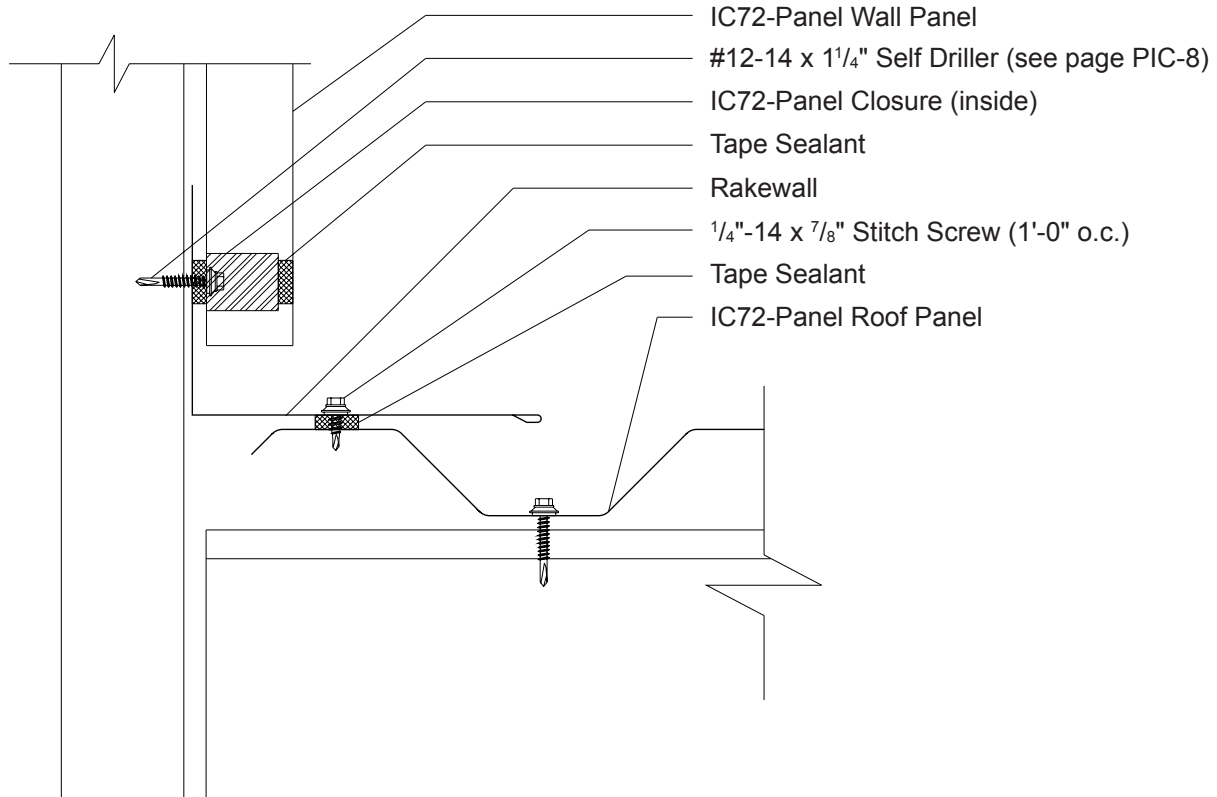

IC72-PANEL

ENDWALL DETAIL

1:12 Minimum
Roof Slope

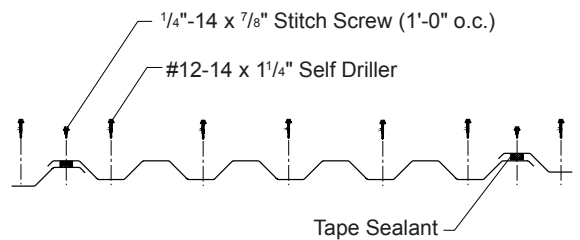
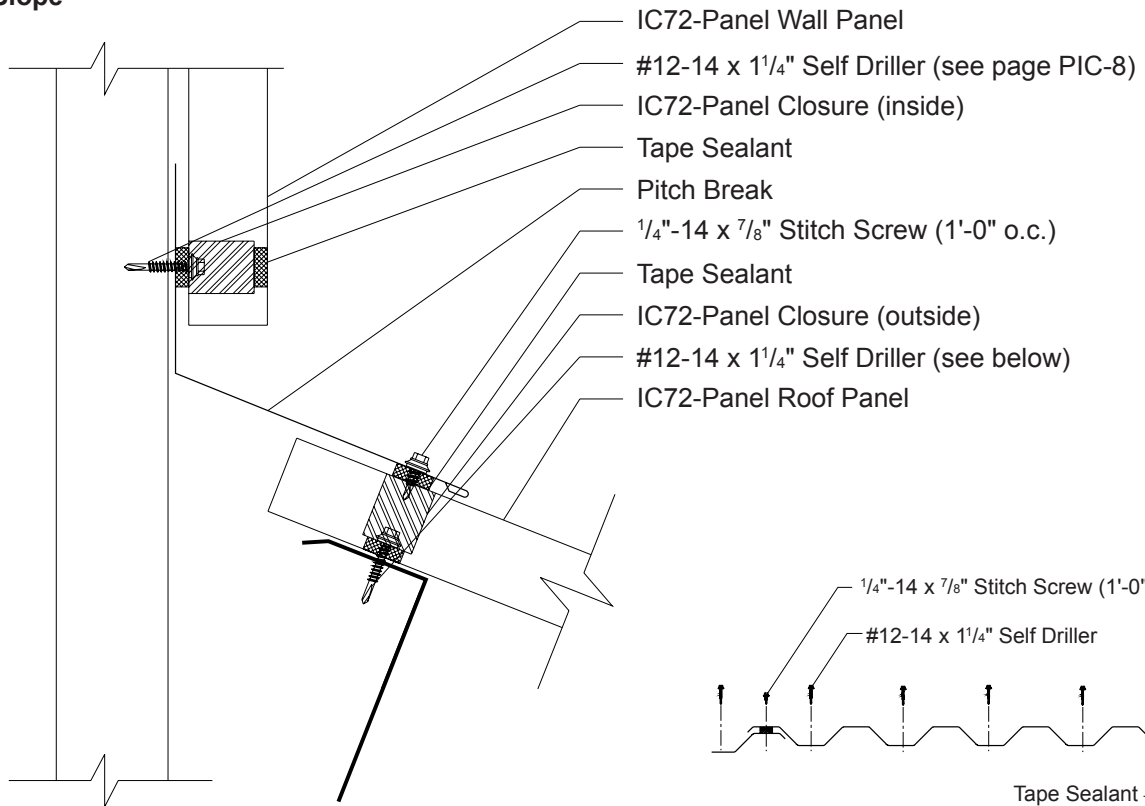

IC72-Panel Roof Fastening Pattern

IC72-PANEL

PEAK DETAIL

1:12 Minimum
Roof Slope

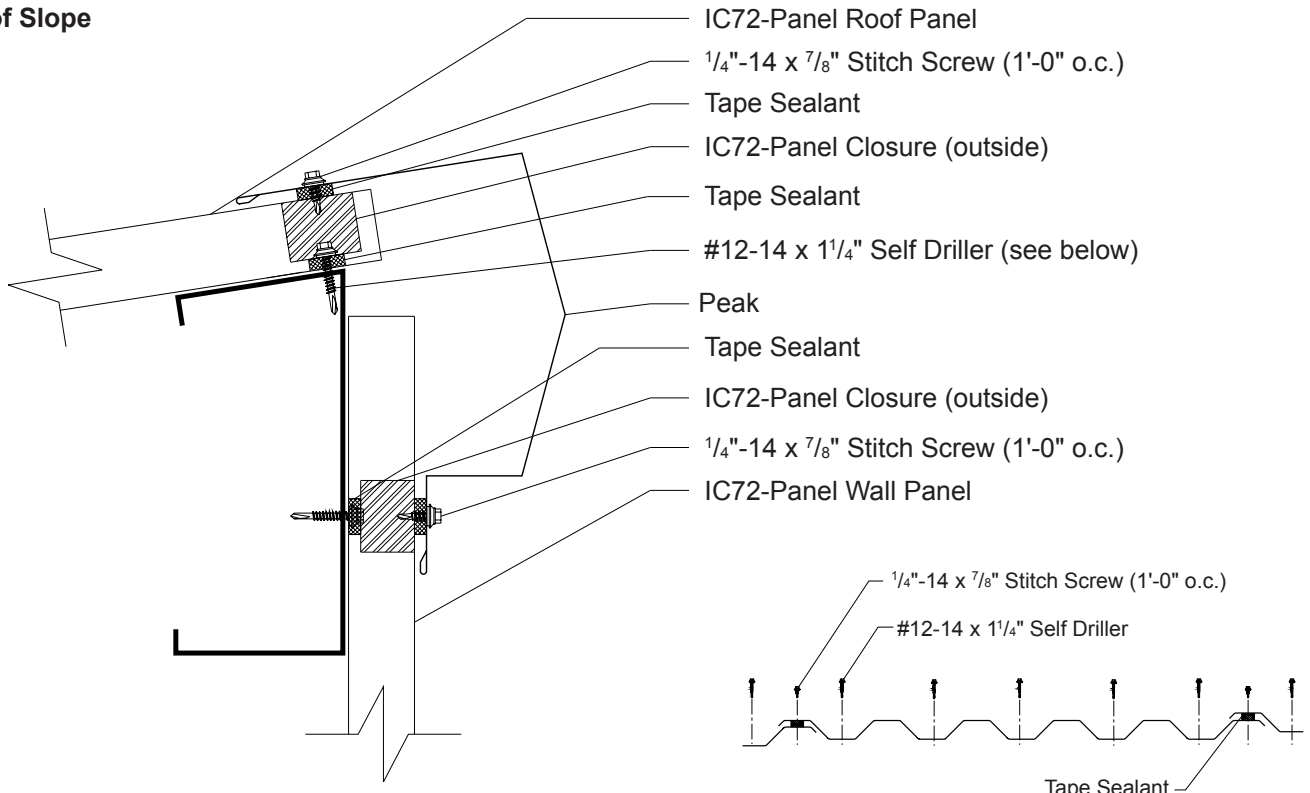

IC72-Panel Roof Fastening Pattern

IC72-PANEL

RIDGE/HIP DETAIL

1:12 Minimum
Roof Slope

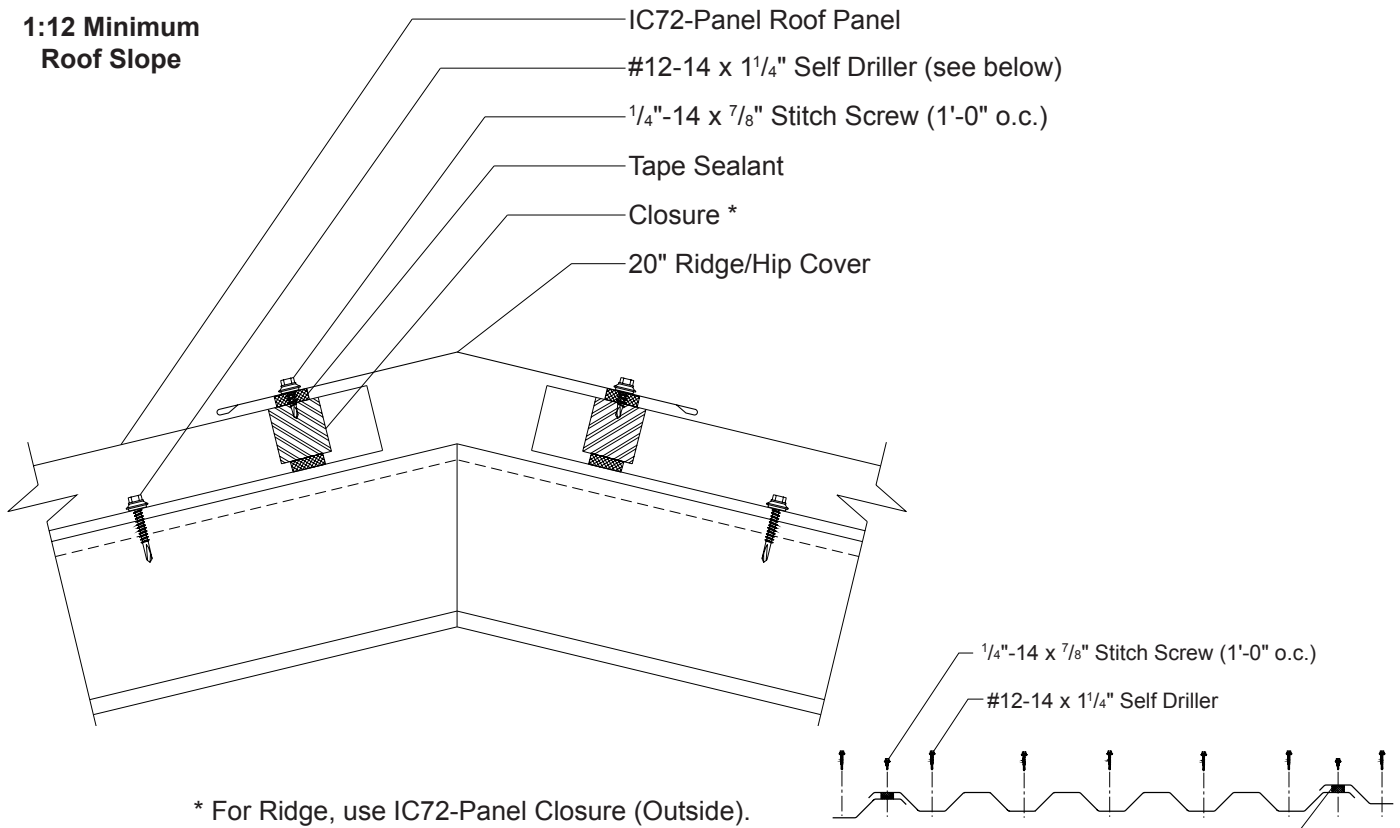

* For Ridge, use IC72-Panel Closure (Outside).
For Hip, use Universal Closure.

IC72-Panel Roof Fastening Pattern

IC72-PANEL

UNIVERSAL RIDGE DETAIL

1:12 Minimum
Roof Slope

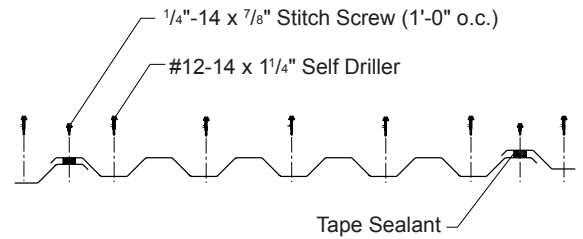
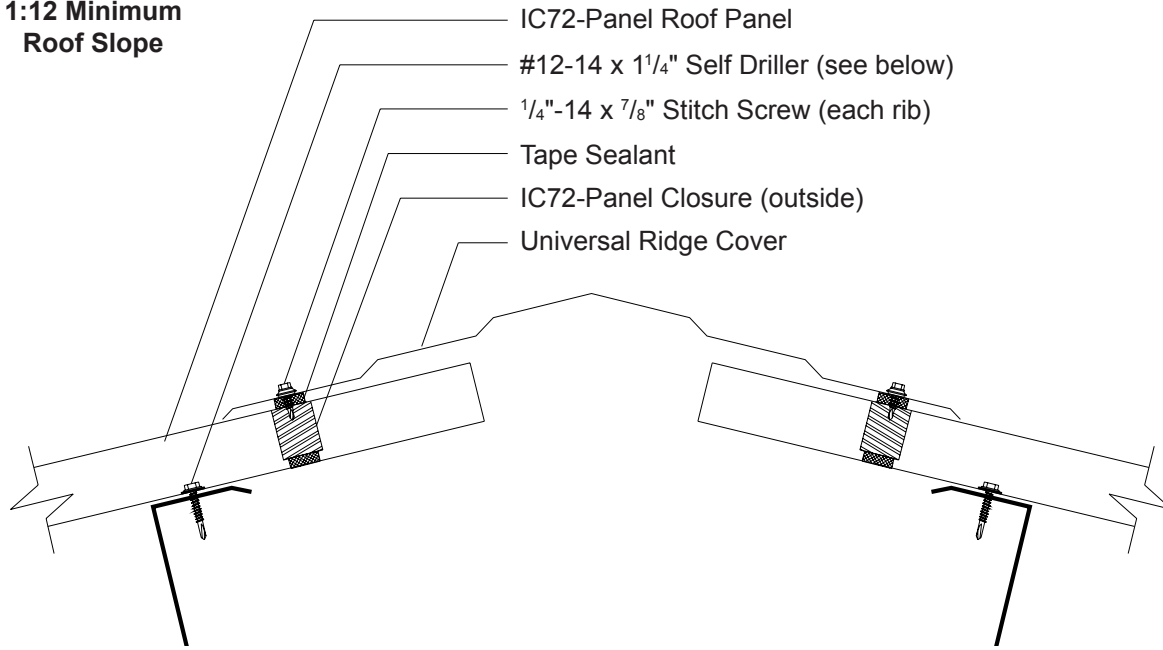

IC72-PANEL

GRAVEL STOP DETAIL

IC72-Panel Roof Fastening Pattern

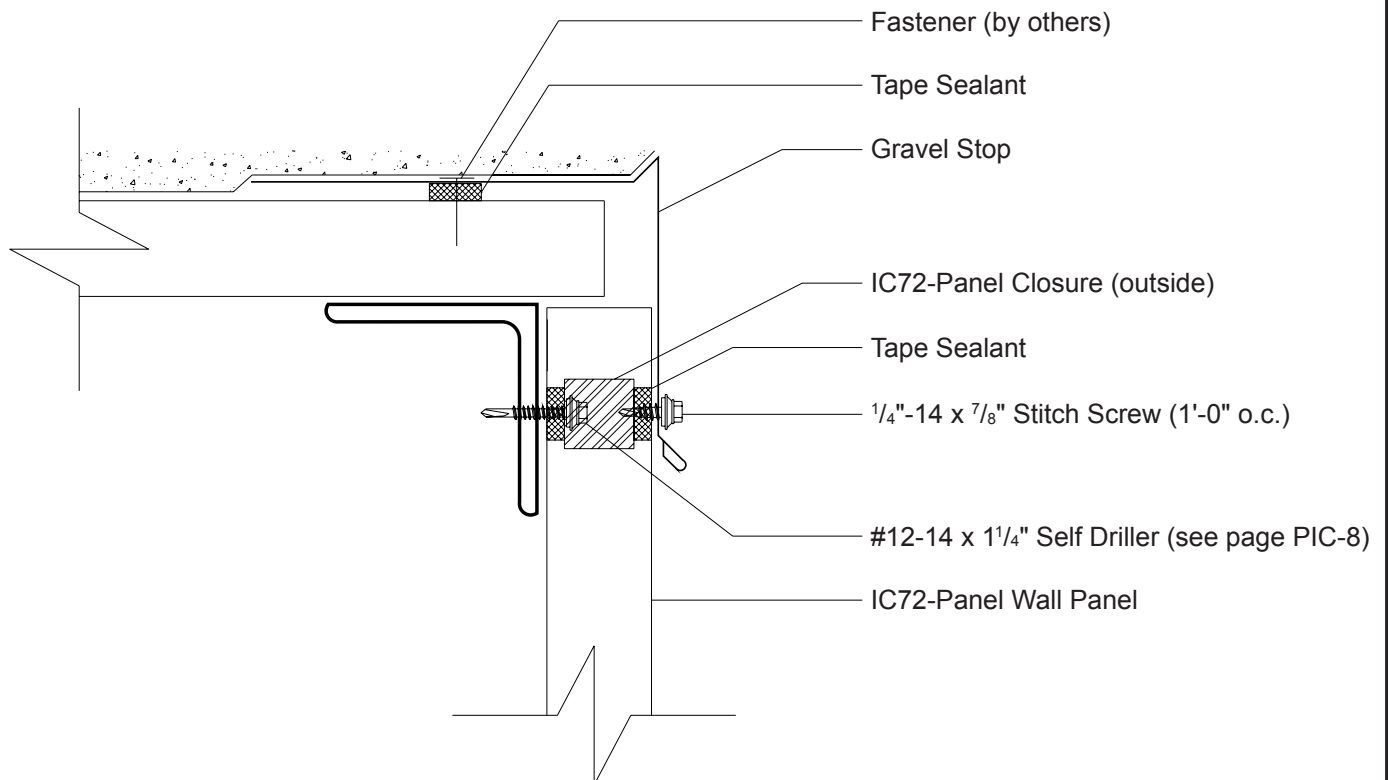

IC72-PANEL

OUTSIDE CORNER DETAIL

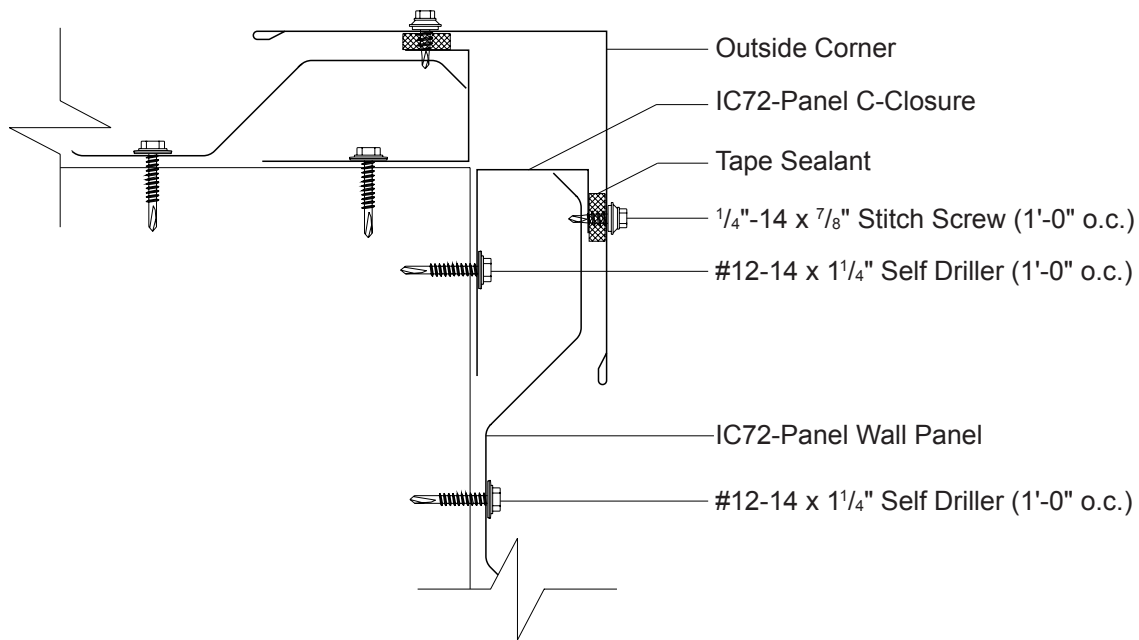

IC72-PANEL

INSIDE CORNER DETAIL

