

# SEAM-LOC 24®

Condensed  
Technical  
Reference

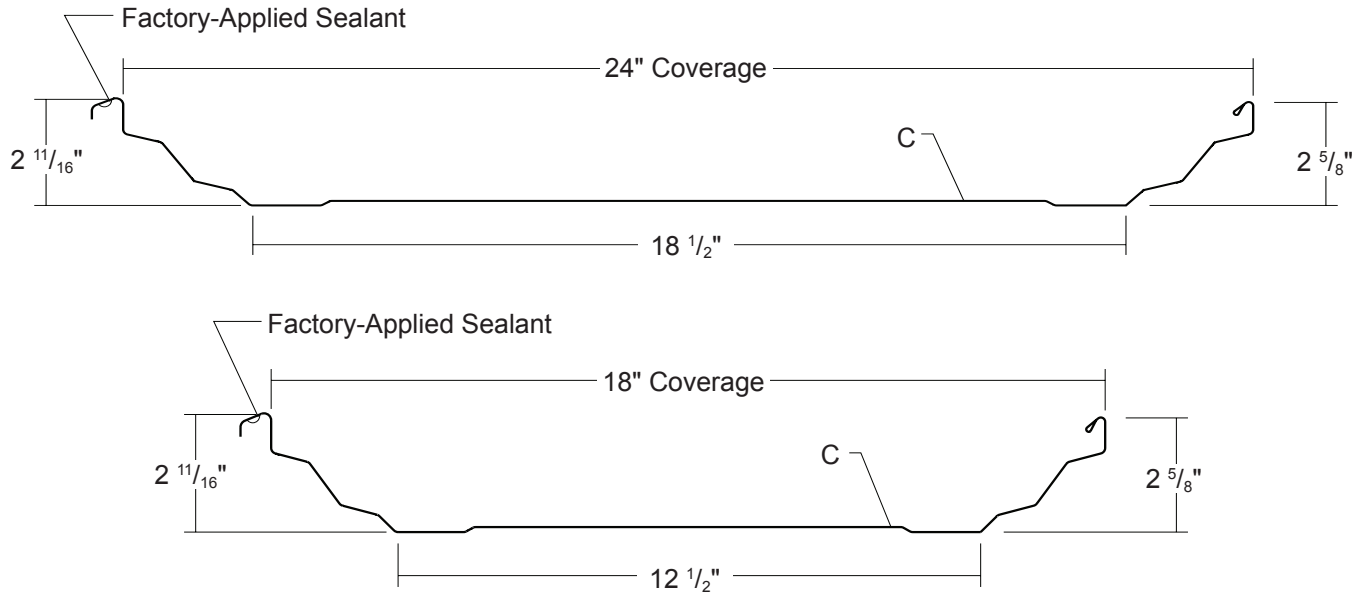

COMMERCIAL  
INDUSTRIAL  
PANEL

CONCEALED  
FASTENED

24" OR 18"  
COVERAGE

MINIMUM  
SLOPE  
1/4:12

OPEN FRAMING OR  
SOLID SUBSTRATE

## PANEL OVERVIEW

- ▶ Finishes: PVDF and Acrylic-Coated Galvalume®
- ▶ Corrosion Protection: AZ55 per ASTM A 792 for unpainted Galvalume®  
AZ50 per ASTM A 792 for painted Galvalume®  
G90 per ASTM A 653 for Galvanized
- ▶ Gauges: 24 ga standard; 22 ga optional
- ▶ 24" or 18" panel coverage, 2 11/16" rib height
- ▶ Panel Length: Minimum: 5'; Maximum: 45' recommended
- ▶ Structural trapezoidal standing seam roof system
- ▶ Pittsburgh double flat locking mechanically-seamed side lap
- ▶ Factory-applied side lap sealant in panel and clip
- ▶ Minimum roof slope: 1/4:12
- ▶ Panels can be factory-notched and punched
- ▶ Accommodates 1/2" to 6" blanket insulation

## TESTING AND APPROVALS

- ▶ UL 2218 Impact Resistance - Class 4
- ▶ UL 790 Fire Resistance Rating - Class A, per building code
- ▶ UL 263 Fire Resistance Rating - per assembly
- ▶ ASTM E 283 Air Leakage - 0.06 cfm/ft² at 6.24 psf
- ▶ ASTM E 331 Water Penetration - none at 6.24 psf
- ▶ ASTM E 1680 Air Leakage - 0.0011 cfm/ft² at 6.24 psf
- ▶ ASTM E 1646 Water Penetration - none at 12 psf
- ▶ ASTM E 1592 Structural Performance
- ▶ UL 580 Uplift Resistance - Class 90 Constructions: #197 and #197A
- ▶ 2020 FBC Approvals - FL10999.8 and FL10999.9

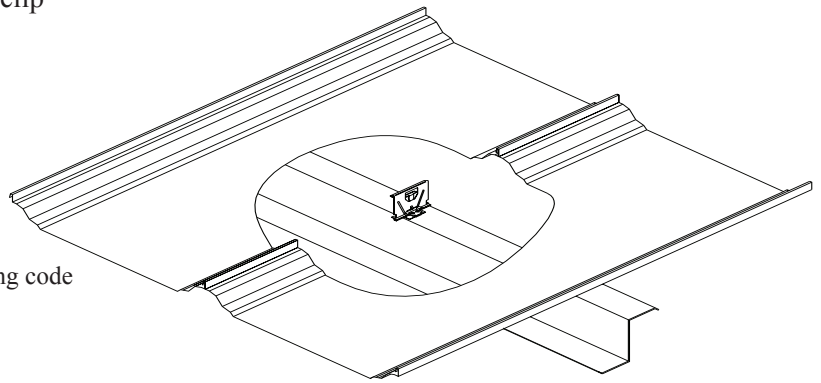

**MMS Metal Sales™**

# SEAM-LOC 24<sup>®</sup>

**Condensed  
Technical  
Reference**

## ATTACHMENT DETAILS

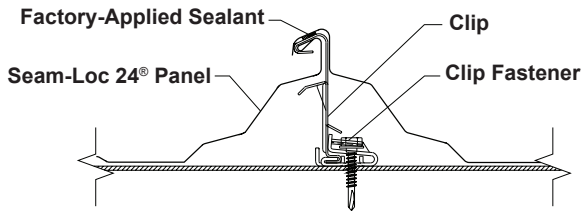

**BEFORE SEAMING**

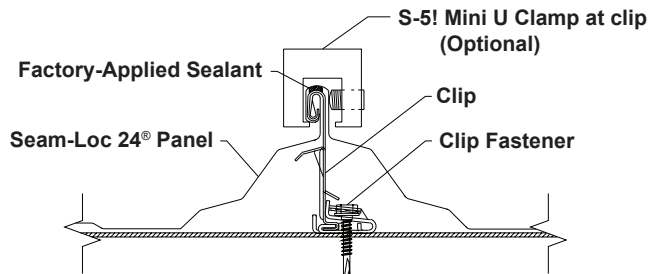

**AFTER SEAMING**

## PANEL CLIP

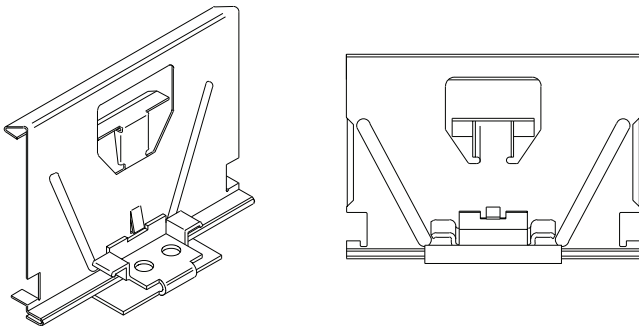

## FASTENING INFORMATION

### ► Clips

Clip spacing is based upon the design loads, the spanning capacity of the panels, the fasteners and the support members.

Clip Tabs are 0.037" thick, G90. Clip base is 0.060" thick, G60.

Floating Clips can accommodate 1-1/2" of thermal movement each way.

### ► Fasteners

Overdriven fasteners will cause panel distortions.

Fasteners should extend 1/2" or more past the inside face of the support material.

Clip Fasteners:

Attaching to Wood:

#10-12 Pancake Head Wood Screw

Attaching to Steel:

<18 ga: 1/4"-14 Deck Screw

>=18 ga, <=12 ga: 1/4"-14 Driller, No Washer

>12 ga: 1/4"-24 Driller, No Washer

Exposed End Fasteners:

At Eave Plate or Compression Plate:

#12-14 XL Driller

Concealed End Fasteners:

At Compression Plate:

#12-14 Driller, No Washer

Trim Fasteners:

1/4"-14 x 7/8" XL Stitch Screw

## SECTION PROPERTIES

Ga	Width in	Yield ksi	Weight psf	Top In Compression		Bottom In Compression	
				I <sub>xx</sub> in <sup>4</sup> /ft	S <sub>xx</sub> in <sup>3</sup> /ft	I <sub>xx</sub> in <sup>4</sup> /ft	S <sub>xx</sub> in <sup>3</sup> /ft
				<b>24</b>	24	50	1.09
<b>24*</b>	24	50	1.09	0.2055	0.0952	0.0920	0.0653
<b>24</b>	18	50	1.15	0.2480	0.1221	0.1220	0.0869
<b>24*</b>	18	50	1.15	0.2480	0.1221	0.1220	0.0869
<b>22</b>	24	50	1.43	0.2725	0.1263	0.1280	0.0882

## ALLOWABLE UNIFORM LOADS, psf For various clip spacings

								Inward Load					Outward Load						
								2'	2.5'	3'	3.5'	4'	5'	2'	2.5'	3'	3.5'	4'	5'
<b>24</b>	24	50	1.09	0.2055	0.0952	0.0920	0.0653	342	227	161	120	93	60	70	64	59	54	49	38
<b>24*</b>	24	50	1.09	0.2055	0.0952	0.0920	0.0653	342	227	161	120	93	60	130	117	104	91	79	53
<b>24</b>	18	50	1.15	0.2480	0.1221	0.1220	0.0869	455	302	214	160	123	80	92	85	77	69	62	46
<b>24*</b>	18	50	1.15	0.2480	0.1221	0.1220	0.0869	455	302	214	160	123	80	167	150	133	116	99	65
<b>22</b>	24	50	1.43	0.2725	0.1263	0.1280	0.0882	458	305	217	161	125	81	74	69	64	59	54	44

- Theoretical section properties have been calculated per AISI 2016 'North American Specification for the Design of Cold-Formed Steel Structural Members'. I<sub>xx</sub> and S<sub>xx</sub> are effective section properties for deflection and bending.
  - Allowable load is calculated in accordance with AISI 2016 specifications considering bending, shear, combined bending & shear and deflection. Allowable load does not address web crippling, fasteners, support material or load testing. Allowable load considers the three or more equal spans condition. Panel weight is not considered.
  - Deflection consideration is limited by a maximum deflection ratio of L/180 of span.
  - Allowable loads do not include a 1/3 stress increase for wind.
- \* - indicates the use of S-5! Mini-U Clamp at panel clip.

**MS Metal Sales<sup>™</sup>**

[metalsales.us.com](http://metalsales.us.com)

Anchorage, AK 866.640.7663  
Bay City, MI 888.777.7640  
Deer Lake, PA 800.544.2577  
Denver, CO 800.289.7663

Detroit Lakes, MN 888.594.1394  
Fontana, CA 800.782.7953  
Fort Smith, AR 877.452.3915  
Independence, MO 800.747.0012

Jacksonville, FL 800.394.4419  
Jefferson, OH 800.321.5833  
Mocksville, NC 800.228.6119  
Nashville, TN 800.251.8508  
Rock Island, IL 800.747.1206  
Rogers, MN 800.328.9316

Seattle, WA 800.431.3470  
Sellersburg, IN 800.999.7777  
Sioux Falls, SD 888.299.0024  
Spokane, WA 800.572.6565  
Temple, TX 800.543.4415  
Woodland, CA 800.759.6019