

TLC-9 WALL PANEL

Condensed
Technical
Reference

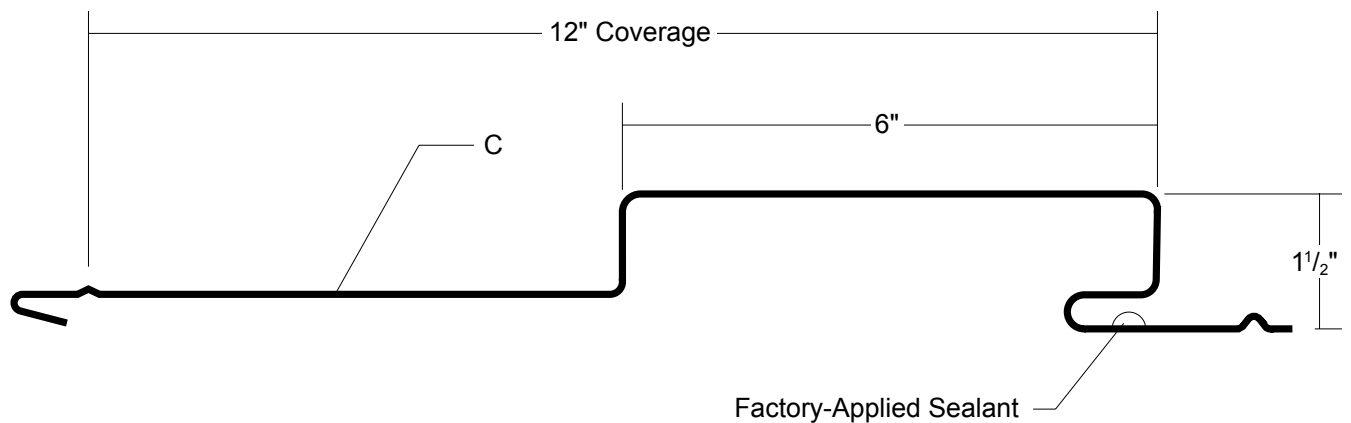

ARCHITECTURAL
COMMERCIAL
INDUSTRIAL
PANEL

CONCEALED
FASTENED

12"
COVERAGE

SOFFIT, FASCIA,
WALL AND LINER
PANEL

OPEN FRAMING OR
SOLID SUBSTRATE

PANEL OVERVIEW

- ▶ Finish: Standard: PVDF
Optional: multi-pass Kynar 500®, Marblique, Plastisol and Polyester
- ▶ Corrosion Protection: AZ50 per ASTM A 792 for painted Galvalume®
G90 per ASTM A 653 for Galvanized
- ▶ Gauges: 24 ga, 22 ga and 20 ga
- ▶ 12" panel coverage, 1 1/2" panel height
- ▶ Flush face with 6" reveal, concealed fastened, non-end lapping panel system
- ▶ Roll-Formed Panels
- ▶ Panel Length: 5' minimum, 40' maximum
- ▶ Optional material availability: Stainless Steel, Copper and Aluminum
- ▶ Use on single-skin or field-assembled wall systems
- ▶ Panels can be installed horizontally or vertically and are interchangeable for accent effects
- ▶ Custom capabilities include:
 - Perforated panels for wind screens and liner panels

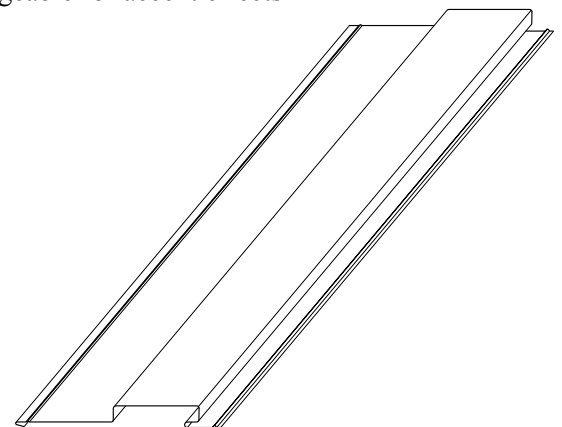

TESTING AND APPROVALS

- ▶ ASTM E 283 Air Leakage
- ▶ ASTM E 331 Water Penetration
- ▶ ASTM E 330 Uniform Static Air Pressure Difference

ms metal sales™
manufacturing corporation

TLC-9 WALL PANEL

**Condensed
Technical
Reference**

FASTENING PATTERN

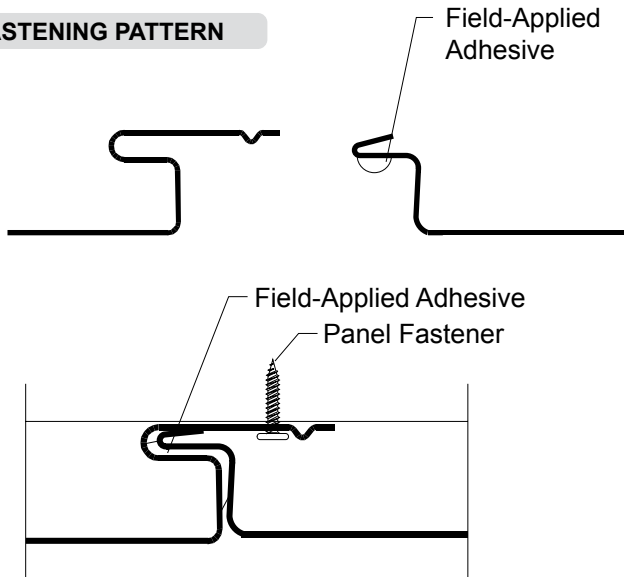

DIRECTIONAL DETAILS

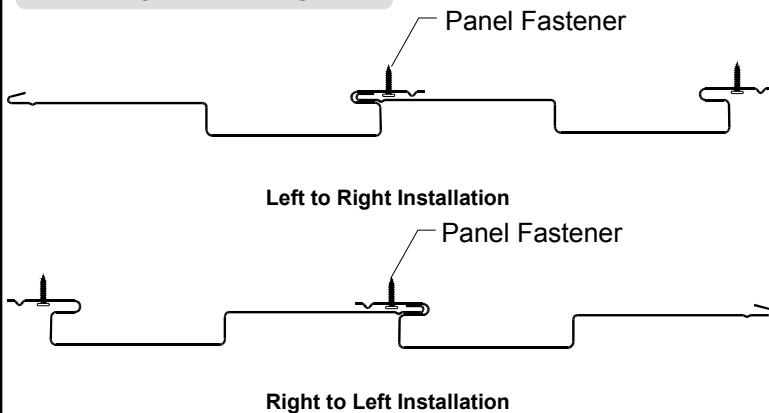

FASTENING INFORMATION

Overdriven fasteners will cause panel distortions.

Fasteners should extend 1/2" or more past the inside face of the support material.

Thick Panels (ex. 18 ga) or supports (ex. 1/2" steel) may require predrilling of holes for screws.

Panel Fasteners:

Attaching to Wood:

#10-12 Pancake Head Wood Screw

Attaching to Steel:

<18 ga: 1/4"-13 Deck Screw

>=18 ga, <=12 ga: #10-16 Pancake Head Driller

Trim Fasteners:

1/4"-14 x 7/8" XL Stitch Screw

1/8" x 3/16" Pop Rivet

Field-Applied Adhesive:

1/4" diameter bead of SM7108

SECTION PROPERTIES

Ga	Width in	Yield ksi	Weight psf	Top In Compression		Bottom In Compression	
				Ixx in ⁴ /ft	Sxx in ³ /ft	Ixx in ⁴ /ft	Sxx in ³ /ft
24	12	50	1.51	0.0623	0.0592	0.1041	0.1059
22	12	50	1.97	0.0906	0.0879	0.1437	0.1491
20	12	33	2.39	0.1310	0.1329	0.1920	0.2079

ALLOWABLE UNIFORM LOADS, psf For various fastener spacings

								Inward Load						Outward Load					
								2'	3'	4'	6'	6'	8'	2'	3'	4'	5'	6'	8'
24	12	50	1.51	0.0623	0.0592	0.1041	0.1059	90	81	73	54	38	21	90	81	73	54	38	21
22	12	50	1.97	0.0906	0.0879	0.1437	0.1491	90	81	72	62	53	32	90	81	72	62	53	32
20	12	33	2.39	0.1310	0.1329	0.1920	0.2079	90	81	72	62	53	31	90	81	72	62	53	31

- Theoretical section properties have been calculated per AISI 2016 'North American Specification for the Design of Cold-Formed Steel Structural Members'. Ixx and Sxx are effective section properties for deflection and bending.
- Allowable load is calculated in accordance with AISI 2016 specifications considering bending, shear, combined bending and shear and deflection. Allowable load considers the 3 or more equal spans condition. Allowable load does not address web crippling, fasteners, support material or load testing. Panel weight is not considered.
- Deflection consideration is limited by a maximum deflection ratio of L/180 of span.
- Allowable loads do not include a 1/3 stress increase for wind.

ms metal sales
manufacturing corporation

metalsales.us.com

Anchorage, AK 866.640.7663
Bay City, MI 888.777.7640
Deer Lake, PA 800.544.2577
Denver, CO 800.289.7663

Detroit Lakes, MN 888.594.1394
Fontana, CA 800.782.7953
Fort Smith, AR 877.452.3915
Independence, MO 800.747.0012

Jacksonville, FL 800.394.4419
Jefferson, OH 800.321.5833
Mocksville, NC 800.228.6119
Nashville, TN 800.251.8508
Rock Island, IL 800.747.1206
Rogers, MN 800.328.9316

Seattle, WA 800.431.3470
Sellersburg, IN 800.999.7777
Sioux Falls, SD 888.299.0024
Spokane, WA 800.572.6565
Temple, TX 800.543.4415
Woodland, CA 800.759.6019

©MSMC/3-2020