

Streamline®

**PRS COPPER
PRESS FITTINGS
CATALOG**



C
COPPER

PR
PRESS

PM
PLBG/MECH

 **MUELLER
STREAMLINE CO.**



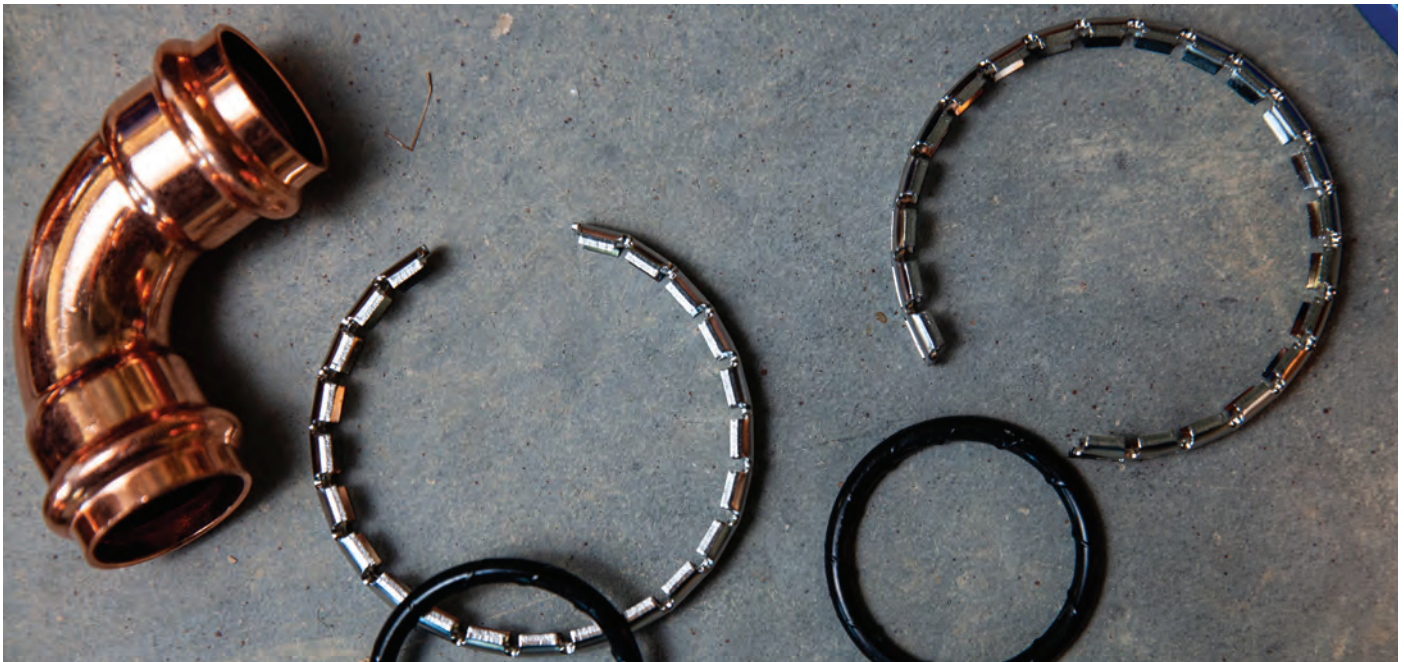

Streamline[®] PRS Copper Press Fittings are the trusted, quality solution to flameless copper joining for plumbing and mechanical applications.

- Broad offering of 350+ fittings
- Available in diameters ranging from 1/2" - 4"
- Extensive offering of reducing tees
- Leak detection feature helps identify un-crimped connections
- Compatible with most common pressing tools and jaws in the market
- EPDM (Ethylene Propylene Diene Monomer) seals are factory-installed & lubricated
- Packaged in common industry quantities
- Meets lead-free and drinking water requirements of NSF
- Connections can be made wet or dry for quick repairs on existing systems

TABLE OF CONTENTS

BENEFITS	4	DIMENSIONAL DATA	10-19
FEATURES & HIGHLIGHTS	5	INSTALLATION INSTRUCTIONS	20-27
TOOLS & JAW COMPATIBILITY	6	TESTING WITH LEAK DETECTION	24
APPLICATIONS	7	INSTALLATION GUIDELINES	28-29
SYSTEM DATA	9	FAQ'S	30-31



WHY STREAMLINE® PRS COPPER PRESS FITTINGS?

Press technology is growing in use as installers seek alternative methods due to skilled labor constraints and other factors. Its common piping system applications today range from those in new commercial building construction, to MRO factory maintenance, to retrofit and remodel of existing flow control systems. Since the first design was patented, there have been a number of important evolutionary modifications. These improvements have been focused on providing greater ease of installation and on increasing the reliability of modern press technology.

Streamline® PRS Copper Press Fittings build upon these advancements and continue the quest of

improved joint design, increased holding power, and greater reliability. With patented design improvements and rigorous testing requirements, we are confident that we have accomplished all of these objectives.

We understand that press tool and jaw sets are an expensive investment for the contractor and inventory item for wholesalers. Therefore, we focused on improvements to the seal mechanics, rather than the basic design of the fitting. With our design, Streamline® PRS Copper Press Fittings are compatible with most tools and jaws on the market, making it easy for the end user.

SURE PRS™ SEAL TECHNOLOGY

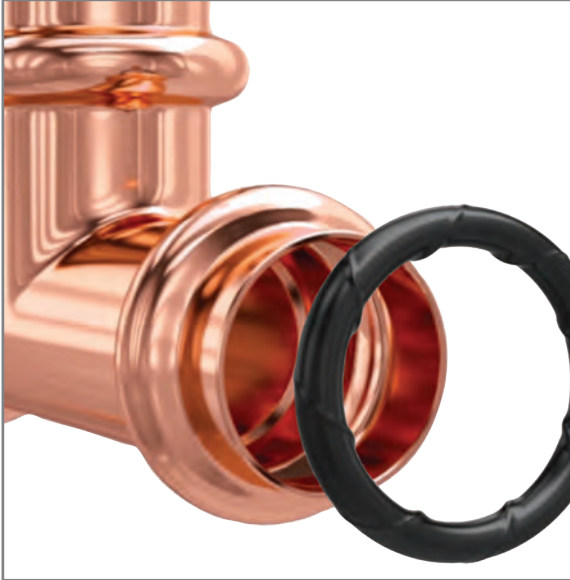

O-RING INSIDE FITTING

- Available in 1/2" - 2" fitting designs.
- Proprietary EPDM O-ring seal with circumferential leak path.
- Leak detection helps identify un-pressed connections at multiple points of the fitting hub.

DUOBITE™ GRIP RING



GRIP RING DETAIL

- Available in 2-1/2" - 4" fitting designs.*
- Dual rows of matching stainless steel teeth provide maximum joint strength.
- Stainless steel teeth "bite" into the tube when the joint is pressed.

**2 1/2" - 4" connections are inherently "leak detecting". Before pressing, fittings are loose on the tube, allowing for water/air flow to help identify un-pressed connections.*



TOOLS & JAW COMPATIBILITY

Using the performance requirements outlined in ASME B16.51, and in-house testing requirements in conjunction with operational instructions provided by various tool and jaw manufacturers, the tools and jaws listed below are compatible with Streamline® PRS Copper Press Fittings.

It is important to follow the specific manufacturer's guidelines for best use and practice and for required and periodic maintenance of both the tool and jaws used in copper press systems. Failure to do so may void the tool and jaw manufacturers' warranties and cause improper pressing of fittings.

For additional information regarding manufacturers' tools and/or jaw sets, refer to the individual websites of the specific manufacturer. Individual tool and jaw manufacturers recommended maintenance and calibration schedules vary. Be sure to follow the instructions specific to the brand of tool and jaw set being used.

1/2" – 1"

- NIBCO Mini Tool w/Mini Jaws
- Rothenberger Compact Tool w/Compact Jaws

1/2" – 1-1/4"

- Milwaukee M12 Tool w/Compact Jaws
- REMS Mini Tool w/Mini Jaws
- Ridgid Compact Tools w/Compact Jaws
- Klauke MAP Tool w/Mini Jaws

1/2" – 2"

- Milwaukee M18 FORCE LOGIC™ Tool w/Standard Jaws
- NIBCO Standard Tool w/Standard Jaws
- REMS Standard Tools w/Standard Jaws
- Ridgid Standard Tools w/Standard Jaws
- Rothenberger Standard Tools w/Standard Jaws
- Klauke UPA Tool w/Standard Jaws
- DeWalt 20V Max Tool w/Standard Jaws
- Hilti Press Tool NPR 32-A22

2-1/2" – 4"

- Milwaukee M18 FORCE LOGIC™ Tools w/Rings & Ring Jaw
- REMS Standard Tools w/Rings & Z5 Adapter Tong
- Ridgid Standard Tools w/ Rings & V2 Actuator Jaw
- Hilti Press Rings & Actuator

APPLICATIONS

Streamline® PRS Copper Press Fittings are designed to be joined with ASTM B88 seamless copper water tube (K, L, & M) in residential and commercial plumbing and mechanical systems. Listed below are common applications approved for Streamline® PRS Copper Press Fittings.

TYPES OF SERVICE	COMMENTS	PRESSURE	TEMPERATURE	COMPATIBLE WITH EPDM SEAL
Fluids/Water Potable				
Hot and Cold Water	—	300 PSI	32°F to 250°F	✓
Rainwater / Grey Water	—	300 PSI	-20°F to 250°F	✓
Hydronic Heating	Up to 50% Ethylene Glycol or Propylene Glycol solution	300 PSI	-20°F to 250°F	✓
Cooling Water	Up to 50% Ethylene Glycol or Propylene Glycol solution	300 PSI	-20°F to 250°F	✓
Low-Pressure Steam	—	UP TO 5 PSI	248°F	✓
Fuel, Oil and Lubricant				
Ethanol	Pure Grain Alcohol	200 PSI	—	✓
Non-Medical Gases				
Compressed Air	Less than 25mg/m ³ oil content	200 PSI	Up to 140°F	✓
Oxygen - O ₂ (non medical)	Keep oil and fat free/non-liquid O ₂	140 PSI	Up to 140°F	✓
Nitrogen - N ₂	—	200 PSI	Up to 140°F	✓
Argon	Welding Use	200 PSI	Up to 140°F	✓
Hydrogen - H ₂	—	125 PSI	Up to 140°F	✓
Vacuum	—	Max 29.2 inches of Mercury	Up to 140°F	✓
Carbon Dioxide - CO ₂	Dry	—	Up to 140°F	✓

Contact Customer Service for information on applications not listed and applications outside the temperature and pressure ranges listed above.

Fluids containing hydrocarbon-based oils are not compatible with the EPDM seal.





Streamline® PRS Copper Press Fittings are for use in plumbing and mechanical applications. Product is designed to join ASTM B88 hard-drawn copper tube (Types K, L, M) from 1/2" to 4" and soft (annealed) copper tube up to 1-1/4".

OPERATING PARAMETERS:

- Operating Pressure: 300 PSI CWP max
- Operating Temperature Range: -20°F — 250°F

ADVANTAGES:

- Fast, flameless, and easy to use
- Permanent connections
- Size range from 1/2" to 4"
- Large selection of fittings
- Consistent professional appearance
- Less equipment required
- Environmentally friendly system
- Compatibility of fittings and tools

APPROVALS & CERTIFICATIONS:

- | | |
|----------------|----------------|
| • ASME B16.51 | • NSF/ANSI 372 |
| • IAPMO PS-117 | • CSA |
| • NSF/ANSI 61 | • ABS |

APPROVED SYSTEMS:

- Potable water
- Hydronic heating (w/ glycol)
- Chilled water
- Compressed air (200 PSI max)
- Non-medical gases (140 PSI max)
- Low pressure steam (up to 5 PSI)
- Vacuum (Max 29.2 inches of Mercury Up to 140°F)

WARRANTY:

Streamline® PRS Copper Press Fittings carry a 50-year limited warranty against defects in material and workmanship.



C
COPPER

PR
PRESS

PM
PLBG/MECH

DIMENSIONAL DATA

45° ELBOW • SMALL
P X P

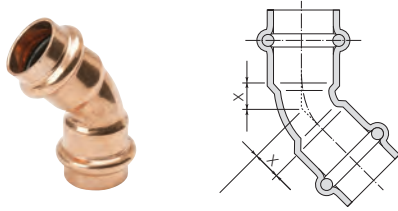

Item No.	Diameter	Approx Wt Lbs / Pc	Inner Qty Pcs / Bag	Master Qty Pcs / Box	Dimensions (in.)	
					X	Z
PF 03026	1/2"	0.10	10	400	0.28	
PF 03034	3/4"	0.15	10	200	0.37	
PF 03044	1"	0.21	5	140	0.45	
PF 03050	1-1/4"	0.30	1	70	0.51	
PF 03055	1-1/2"	0.58	1	40	0.59	
PF 03059	2"	0.82	1	25	0.79	

45° ELBOW • STREET • LARGE
FTG X P

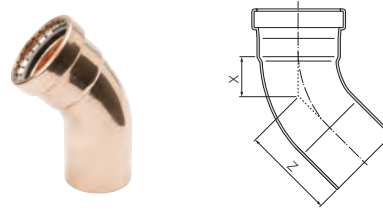

Item No.	Diameter	Approx Wt Lbs / Pc	Inner Qty Pcs / Bag	Master Qty Pcs / Box	Dimensions (in.)	
					X	Z
PF 03363	2-1/2"	1.57	1	18	1.30	3.23
PF 03368	3"	2.32	1	12	1.57	3.50
PF 03373	4"	3.96	1	6	2.07	4.59

45° ELBOW • LARGE
P X P

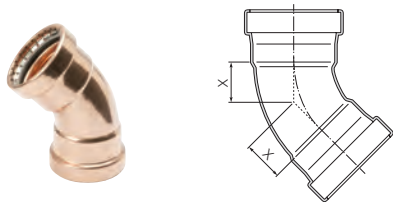

Item No.	Diameter	Approx Wt Lbs / Pc	Inner Qty Pcs / Bag	Master Qty Pcs / Box	Dimensions (in.)	
					X	Z
PF 03063	2-1/2"	1.74	1	16	1.30	
PF 03067	3"	2.27	1	12	1.57	
PF 03073	4"	4.11	1	6	2.07	

90° ELBOW • SHORT RADIUS • SMALL
P X P

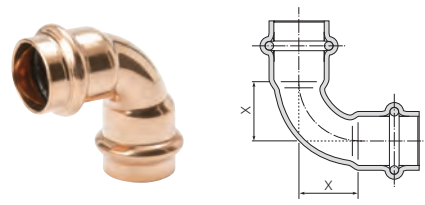

Item No.	Diameter	Approx Wt Lbs / Pc	Inner Qty Pcs / Bag	Master Qty Pcs / Box	Dimensions (in.)	
					X	Z
PF 02722	1/2"	0.12	10	350	0.75	
PF 01634	3/4"	0.18	10	180	0.75	
PF 01647	1"	0.28	5	100	1.22	
PF 02084	1-1/4"	0.35	1	55	1.22	
PF 02085	1-1/2"	0.63	1	35	1.24	
PF 02086	2"	1.07	1	18	2.05	

45° ELBOW • STREET • SMALL
FTG X P

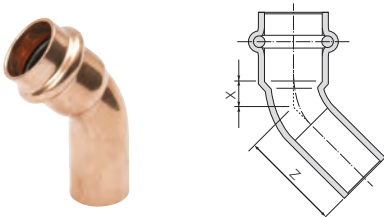

Item No.	Diameter	Approx Wt Lbs / Pc	Inner Qty Pcs / Bag	Master Qty Pcs / Box	Dimensions (in.)	
					X	Z
PF 03326	1/2"	0.09	10	450	0.28	1.10
PF 03334	3/4"	0.15	10	260	0.37	1.32
PF 03344	1"	0.20	5	140	0.45	1.44
PF 03350	1-1/4"	0.28	1	70	0.51	1.67
PF 03355	1-1/2"	0.56	1	40	0.59	2.13
PF 03359	2"	0.80	1	25	0.79	2.48

90° ELBOW • LONG RADIUS • SMALL
P X P

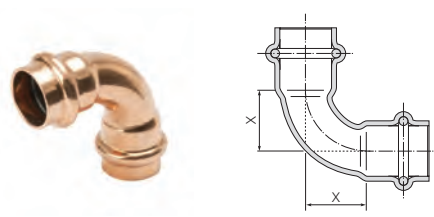

Item No.	Diameter	Approx Wt Lbs / Pc	Inner Qty Pcs / Bag	Master Qty Pcs / Box	Dimensions (in.)	
					X	Z
PF 02722	1/2"	0.12	10	350	0.75	
PF 02734	3/4"	0.20	10	180	1.30	
PF 02747	1"	0.29	5	100	1.30	
PF 02055	1-1/4"	0.40	1	55	1.65	
PF 02063	1-1/2"	0.79	1	35	2.01	
PF 02072	2"	1.21	1	18	2.52	

C
COPPER

PR
PRESS

PM
PLBG/MECH

90° ELBOW • LONG RADIUS • LARGE P X P

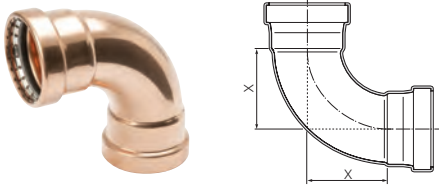

Item No.	Diameter	Approx Wt Lbs / Pc	Inner Qty Pcs / Bag	Master Qty Pcs / Box	Dimensions (in.)	
					X	X
PF 02082	2-1/2"	2.10	1	12	2.99	
PF 02092	3"	2.10	1	9	3.58	
PF 02095	4"	5.62	1	4	4.74	

90° ELBOW • LONG RADIUS • STREET • SMALL FTG X P

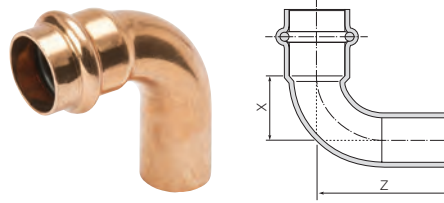

Item No.	Diameter	Approx Wt Lbs / Pc	Inner Qty Pcs / Bag	Master Qty Pcs / Box	Dimensions (in.)	
					X	Z
PF 02822	1/2"	0.11	10	400	0.75	1.57
PF 02834	3/4"	0.19	10	200	1.02	2.01
PF 02847	1"	0.27	5	100	1.30	2.28
PF 02350	1-1/4"	0.41	1	55	1.65	2.83
PF 02355	1-1/2"	0.76	1	35	2.01	3.52
PF 02359	2"	1.16	1	20	2.52	4.15

90° ELBOW • LONG RADIUS REDUCING • SMALL P X P

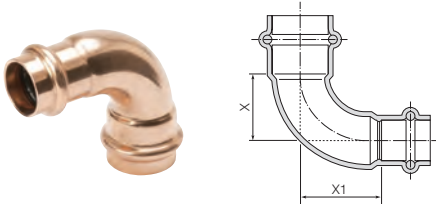

Item No.	Diameter	Approx Wt Lbs / Pc	Inner Qty Pcs / Bag	Master Qty Pcs / Box	Dimensions (in.)	
					X	X1
PF 02736	3/4" x 1/2"	0.19	15	240	1.02	1.26
PF 02749	1" x 3/4"	0.30	10	120	1.30	1.56

90° ELBOW • LONG RADIUS • STREET • LARGE FTG X P

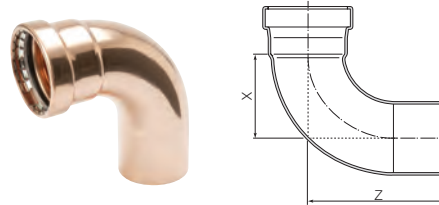

Item No.	Diameter	Approx Wt Lbs / Pc	Inner Qty Pcs / Bag	Master Qty Pcs / Box	Dimensions (in.)	
					X	Z
PF 02363	2-1/2"	2.05	1	14	2.99	5.00
PF 02368	3"	3.04	1	9	3.58	5.58
PF 02395	4"	5.70	1	4	4.74	7.05

90° ELBOW • SHORT RADIUS • STREET • SMALL FTG X P

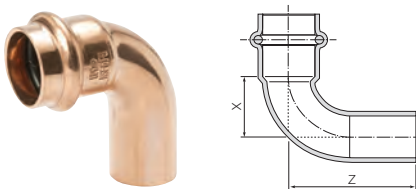

Item No.	Diameter	Approx Wt Lbs / Pc	Inner Qty Pcs / Bag	Master Qty Pcs / Box	Dimensions (in.)	
					X	Z
PF 01654	3/4"	0.16	10	200	0.75	2.01
PF 02344	1"	0.27	5	100	1.22	2.28
PF 02384	1-1/4"	0.35	1	55	1.22	2.84
PF 02385	1-1/2"	0.64	1	35	1.24	3.52
PF 02386	2"	1.05	1	20	2.05	4.15

C
COPPER

PR
PRESS

PM
PLBG/MECH

DIMENSIONAL DATA

90° ELBOW • MALE • SMALL
P X MPT

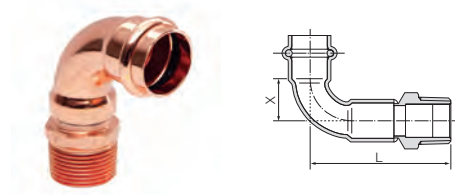

Item No.	Diameter	Approx Wt Lbs / Pc	Inner Qty Pcs / Bag	Master Qty Pcs / Box	Dimensions (in.)	
					L	X
PF 01506	1/2"	0.23	5	200	2.82	0.75
PF 01531	3/4"	0.39	5	120	3.36	1.02
PF 01558	1"	0.60	1	65	3.76	1.30
PF 01593	1-1/4"	0.81	1	45	4.41	1.65
PF 01631	1-1/2"	1.42	1	25	5.22	2.01
PF 01679	2"	2.12	1	15	5.98	2.52

ADAPTER • FEMALE • SMALL
P X FPT

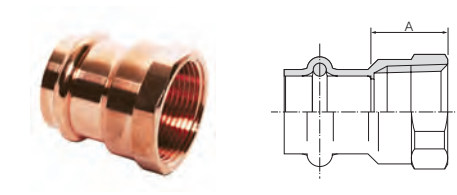

Item No.	Diameter	Approx Wt Lbs / Pc	Inner Qty Pcs / Bag	Master Qty Pcs / Box	Dimensions (in.)
					A
PF 01231	1/2"	0.10	10	300	0.70
PF 01246	3/4"	0.17	10	150	0.87
PF 01263	1"	0.25	10	180	0.89
PF 01271	1-1/4"	0.35	1	80	0.96
PF 01279	1-1/2"	0.53	1	55	1.02
PF 01287	2"	0.78	1	40	1.06

90° ELBOW • FEMALE • SMALL
P X FPT

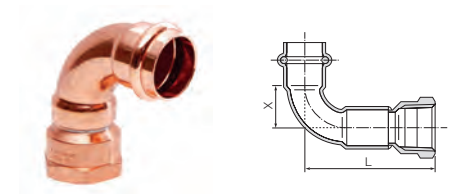

Item No.	Diameter	Approx Wt Lbs / Pc	Inner Qty Pcs / Bag	Master Qty Pcs / Box	Dimensions (in.)	
					L	X
PF 01507	1/2"	0.23	5	200	2.65	0.75
PF 01532	3/4"	0.37	5	120	3.24	1.02
PF 01559	1"	0.55	1	60	3.57	1.30
PF 01594	1-1/4"	0.74	1	45	4.13	1.65
PF 01632	1-1/2"	1.34	1	25	4.95	2.01
PF 01680	2"	1.98	1	15	5.67	2.52

ADAPTER • FEMALE • LARGE
P X FPT

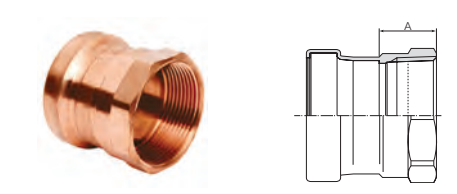

Item No.	Diameter	Approx Wt Lbs / Pc	Inner Qty Pcs / Bag	Master Qty Pcs / Box	Dimensions (in.)
					A
PF 01296	2-1/2"	1.25	1	36	1.30
PF 01297	3"	1.85	1	24	1.54

90° ELBOW • DROP EAR • SMALL
P X FPT

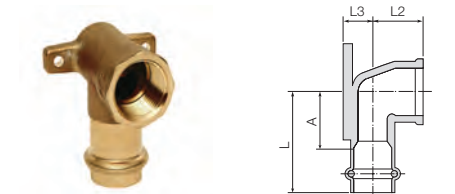

Item No.	Diameter	Approx Wt Lbs / Pc	Inner Qty Pcs / Bag	Master Qty Pcs / Box	Dimensions (in.)			
					A	L	L2	L3
PF 01508	1/2"	0.25	5	100	0.88	1.63	0.76	0.75
PF 02581	3/4"	0.44	5	60	1.09	2.00	1.25	0.87

ADAPTER • FEMALE • REDUCING • SMALL
P X FPT

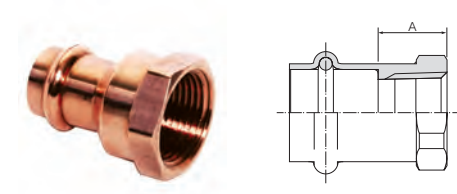

Item No.	Diameter	Approx Wt Lbs / Pc	Inner Qty Pcs / Bag	Master Qty Pcs / Box	Dimensions (in.)
					A
PF 01232	1/2" x 3/8"	0.07	10	300	0.53
PF 01230	1/2" x 3/4"	0.15	10	180	0.98
PF 01247	3/4" x 1/2"	0.17	10	180	0.71
PF 01265	1" x 1/2"	0.29	10	120	0.73
PF 01264	1" x 3/4"	0.22	10	200	0.71
PF 01261	1" x 1-1/4"	0.46	10	60	1.40
PF 01272	1-1/4" x 1"	0.29	1	100	0.85
PF 01270	1-1/4" x 1-1/2"	0.62	1	70	1.56
PF 01280	1-1/2" x 1-1/4"	0.46	1	70	0.94

C
COPPER

PR
PRESS

PM
PLBG/MECH

ADAPTER • FEMALE • STREET • SMALL FTG X FPT

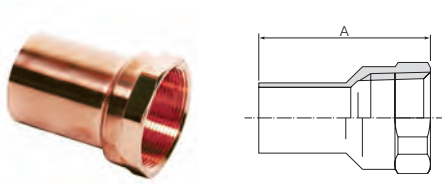

Item No.	Diameter	Approx Wt Lbs / Pc	Inner Qty Pcs / Bag	Master Qty Pcs / Box	Dimensions (in.)	
					A	
PF 15310	1/2"	0.09	5	250	1.59	
PF 01546	3/4"	0.15	5	150	1.90	
PF 01563	1"	0.23	1	110	1.96	
PF 01571	1-1/4"	0.32	1	100	2.17	
PF 01579	1-1/2"	0.49	1	55	2.63	
PF 01587	2"	0.75	1	40	2.84	

ADAPTER • MALE • LARGE P X MPT

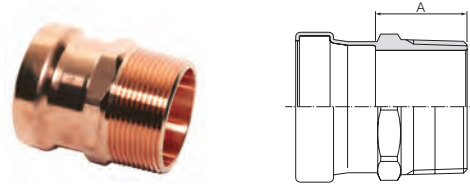

Item No.	Diameter	Approx Wt Lbs / Pc	Inner Qty Pcs / Bag	Master Qty Pcs / Box	Dimensions (in.)	
					A	
PF 01196	2-1/2"	1.62	1	28	1.97	
PF 01199	3"	2.23	1	18	2.11	
PF 01150	4"	3.83	1	12	2.32	

ADAPTER • FEMALE • STREET • REDUCING • SMALL FTG X FPT

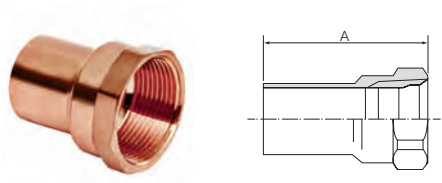

Item No.	Diameter	Approx Wt Lbs / Pc	Inner Qty Pcs / Bag	Master Qty Pcs / Box	Dimensions (in.)	
					A	
PF 01534	1/2" x 3/4"	0.15	5	160	1.87	
PF 01547	3/4" x 1/2"	0.15	5	160	1.81	
PF 01564	1" x 3/4"	0.15	5	250	1.77	

ADAPTER • MALE • REDUCING • SMALL P X MPT

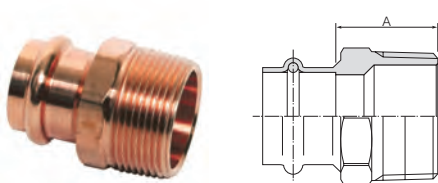

Item No.	Diameter	Approx Wt Lbs / Pc	Inner Qty Pcs / Bag	Master Qty Pcs / Box	Dimensions (in.)	
					A	
PF 01132	1/2" x 3/8"	0.09	10	300	0.71	
PF 01130	1/2" x 3/4"	0.19	10	180	0.97	
PF 01147	3/4" x 1/2"	0.17	10	180	0.90	
PF 01145	3/4" x 1"	0.30	10	200	1.20	
PF 01164	1" x 3/4"	0.24	10	180	0.92	
PF 01162	1" x 1-1/4"	0.45	10	100	1.23	
PF 01172	1-1/4" x 1"	0.35	1	95	1.10	
PF 01170	1-1/4" x 1-1/2"	0.59	1	75	1.30	
PF 01180	1-1/2" x 1-1/4"	0.59	1	55	1.19	
PF 01178	1-1/2" x 2"	1.01	1	40	1.75	
PF 01188	2" x 1-1/2"	0.92	1	40	1.42	

ADAPTER • MALE • SMALL P X MPT

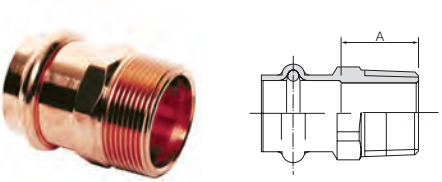

Item No.	Diameter	Approx Wt Lbs / Pc	Inner Qty Pcs / Bag	Master Qty Pcs / Box	Dimensions (in.)	
					A	
PF 01131	1/2"	0.11	10	300	0.89	
PF 01146	3/4"	0.19	10	160	0.89	
PF 01163	1"	0.28	10	160	1.06	
PF 01171	1-1/4"	0.37	1	100	0.99	
PF 01179	1-1/2"	0.63	1	50	1.19	
PF 01187	2"	0.90	1	35	1.28	

ADAPTER • MALE • STREET • SMALL FTG X MPT

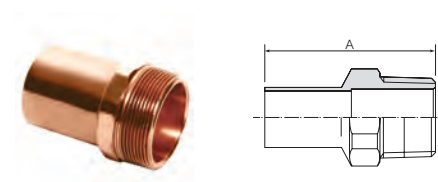

Item No.	Diameter	Approx Wt Lbs / Pc	Inner Qty Pcs / Bag	Master Qty Pcs / Box	Dimensions (in.)	
					A	
PF 01431	1/2"	0.10	5	250	1.75	
PF 01446	3/4"	0.17	5	160	2.02	
PF 01463	1"	0.27	5	200	2.15	
PF 01471	1-1/4"	0.41	1	100	2.44	
PF 01479	1-1/2"	0.59	1	60	2.90	
PF 01487	2"	0.89	1	40	3.15	

C
COPPER

PR
PRESS

PM
PLBG/MECH

DIMENSIONAL DATA

**ADAPTER • MALE • STREET
REDUCING • SMALL FTG X MPT**

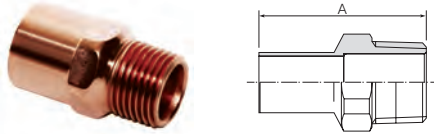

Item No.	Diameter	Approx Wt Lbs / Pc	Inner Qty Pcs / Bag	Master Qty Pcs / Box	Dimensions (in.)	
					A	
PF 01434	1/2" x 3/4"	0.18	5	200	2.05	
PF 01447	3/4" x 1/2"	0.16	5	200	1.95	
PF 01464	1" x 3/4"	0.22	5	200	2.03	

**COUPLING • CROSS OVER • SMALL
P X P**

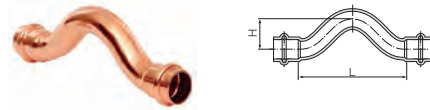

Item No.	Diameter	Approx Wt Lbs / Pc	Inner Qty Pcs / Bag	Master Qty Pcs / Box	Dimensions (in.)	
					H	L
PF 02535	1/2"	0.21	10	200	0.94	3.33
PF 02583	3/4"	0.39	10	100	1.28	4.84

**CAP • SMALL
P**

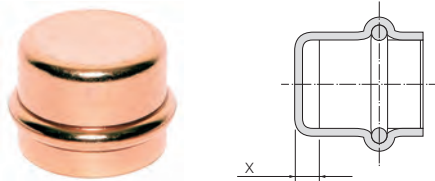

Item No.	Diameter	Approx Wt Lbs / Pc	Inner Qty Pcs / Bag	Master Qty Pcs / Box	Dimensions (in.)	
					X	
ØF007	1/2"	0.05	10	450	0.10	
ØF009	3/4"	0.08	10	450	0.11	
PF 07011	1"	0.10	5	250	0.11	
PF 07012	1-1/4"	0.15	1	100	0.11	
PF 07013	1-1/2"	0.28	1	80	0.12	
PF 07014	2"	0.41	1	55	0.13	

**COUPLING • CROSS OVER • STREET • SMALL
FTG X P**

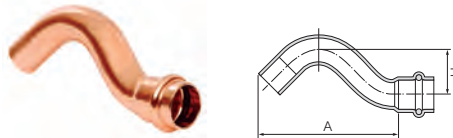

Item No.	Diameter	Approx Wt Lbs / Pc	Inner Qty Pcs / Bag	Master Qty Pcs / Box	Dimensions (in.)	
					A	H
PF 12535	1/2"	0.15	10	250	3.78	0.94
PF 12583	3/4"	0.31	10	100	5.31	1.28

**CAP • LARGE
P**

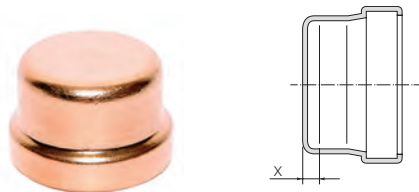

Item No.	Diameter	Approx Wt Lbs / Pc	Inner Qty Pcs / Bag	Master Qty Pcs / Box	Dimensions (in.)	
					X	
PF 07015	2-1/2"	0.68	1	40	0.33	
PF 07016	3"	0.97	1	36	0.33	
PF 07018	4"	1.68	1	24	0.39	

**COUPLING • NO STOP • SMALL
P X P**

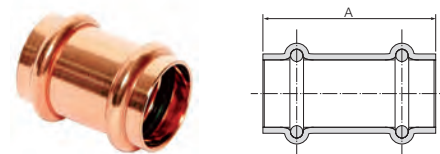

Item No.	Diameter	Approx Wt Lbs / Pc	Inner Qty Pcs / Bag	Master Qty Pcs / Box	Dimensions (in.)	
					A	
PF 01903	1/2"	0.08	10	450	1.50	
PF 01905	3/4"	0.13	10	260	1.81	
PF 01906	1"	0.16	5	170	1.81	
PF 01907	1-1/4"	0.22	1	80	2.05	
PF 01908	1-1/2"	0.46	1	50	2.83	
PF 01909	2"	0.61	1	35	3.15	

C
COPPER

PR
PRESS

PM
PLBG/MECH

COUPLING • NO STOP • LARGE P X P

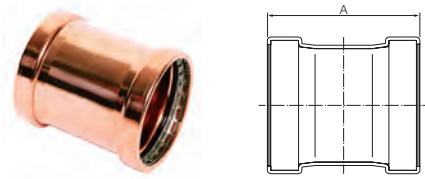

Item No.	Diameter	Approx Wt Lbs / Pc	Inner Qty Pcs / Bag	Master Qty Pcs / Box	Dimensions (in.)
					A
PF 01910	2-1/2"	1.09	1	32	3.54
PF 01911	3"	1.45	1	18	3.86
PF 01913	4"	2.43	1	12	4.49

COUPLING • STAKED STOP • LARGE P X P

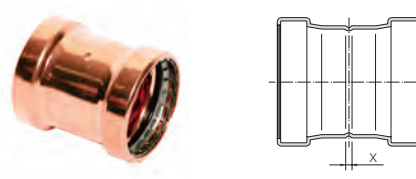

Item No.	Diameter	Approx Wt Lbs / Pc	Inner Qty Pcs / Bag	Master Qty Pcs / Box	Dimensions (in.)
					X
PF 10151	2-1/2"	1.09	1	32	0.16
PF 10152	3"	1.45	1	18	0.16
PF 10154	4"	2.43	1	12	0.16

COUPLING • NO STOP • EXTENDED • SMALL P X P

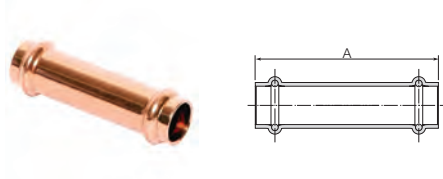

Item No.	Diameter	Approx Wt Lbs / Pc	Inner Qty Pcs / Bag	Master Qty Pcs / Box	Dimensions (in.)
					A
PF 01950	1/2"	0.13	5	250	2.95
PF 01952	3/4"	0.20	5	150	3.41
PF 01955	1"	0.30	5	100	3.94
PF 01956	1-1/4"	0.38	1	60	4.13
PF 01957	1-1/2"	0.70	1	40	4.72
PF 01958	2"	0.95	1	27	5.31

COUPLING • REDUCING • SMALL P X P

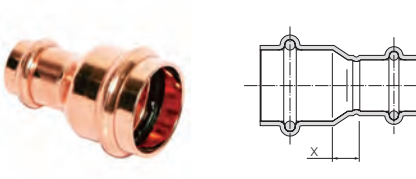

Item No.	Diameter	Approx Wt Lbs / Pc	Inner Qty Pcs / Bag	Master Qty Pcs / Box	Dimensions (in.)
					X
PF 01036	3/4" x 1/2"	0.12	10	300	0.33
PF 01051	1" x 1/2"	0.16	10	200	0.53
PF 01049	1" x 3/4"	0.18	10	200	0.30
PF 01060	1-1/4" x 1/2"	0.21	1	100	0.71
PF 01058	1-1/4" x 3/4"	0.24	1	80	0.51
PF 01056	1-1/4" x 1"	0.23	1	80	0.31
PF 01069	1-1/2" x 1/2"	0.37	1	70	0.91
PF 01067	1-1/2" x 3/4"	0.39	1	70	0.69
PF 01065	1-1/2" x 1"	0.38	1	70	0.49
PF 01064	1-1/2" x 1-1/4"	0.39	1	60	0.37
PF 01079	2" x 1/2"	0.55	1	50	1.28
PF 01077	2" x 3/4"	0.55	1	50	1.10
PF 01075	2" x 1"	0.47	1	50	0.81
PF 01074	2" x 1-1/4"	0.55	1	40	0.73
PF 01073	2" x 1-1/2"	0.64	1	40	0.51

COUPLING • STAKED STOP • SMALL P X P

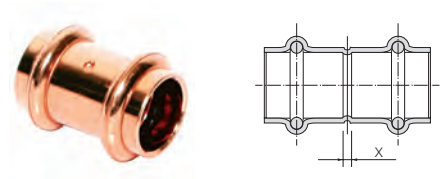

Item No.	Diameter	Approx Wt Lbs / Pc	Inner Qty Pcs / Bag	Master Qty Pcs / Box	Dimensions (in.)
					X
PF 10145	1/2"	0.08	10	550	0.08
PF 10146	3/4"	0.13	10	260	0.08
PF 10147	1"	0.16	5	170	0.08
PF 10148	1-1/4"	0.22	1	80	0.08
PF 10149	1-1/2"	0.46	1	50	0.08
PF 10150	2"	0.61	1	35	0.08

COUPLING • REDUCING • LARGE P X P

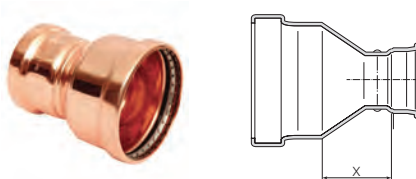

Item No.	Diameter	Approx Wt Lbs / Pc	Inner Qty Pcs / Bag	Master Qty Pcs / Box	Dimensions (in.)
					X
PF 01086	2-1/2" x 1"	0.87	1	40	1.54
PF 01085	2-1/2" x 1-1/4"	0.88	1	40	1.65
PF 01084	2-1/2" x 1-1/2"	1.00	1	40	1.50
PF 01083	2-1/2" x 2"	1.04	1	30	1.12
PF 01095	3" x 1-1/2"	1.26	1	24	1.83
PF 01094	3" x 2"	1.29	1	24	1.50
PF 01093	3" x 2-1/2"	1.43	1	24	1.14
PF 10111	4" x 2"	2.08	1	10	2.24
PF 10110	4" x 2-1/2"	2.19	1	10	1.93
PF 10109	4" x 3"	2.33	1	10	1.54

C
COPPER

PR
PRESS

PM
PLBG/MECH

DIMENSIONAL DATA

FITTING REDUCER • SMALL FTG X P

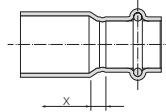

Item No.	Diameter	Approx Wt Lbs / Pc	Inner Qty Pcs / Bag	Master Qty Pcs / Box	Dimensions (in.)	
					X	
PF 01326	3/4" x 1/2"	0.11	10	400	0.20	
PF 01339	1" x 1/2"	0.13	10	300	0.41	
PF 01337	1" x 3/4"	0.15	10	240	0.24	
PF 01347	1-1/4" x 1/2"	0.17	5	180	0.59	
PF 01345	1-1/4" x 3/4"	0.20	5	170	0.47	
PF 01343	1-1/4" x 1"	0.19	5	150	0.24	
PF 01355	1-1/2" x 1/2"	0.27	5	130	0.79	
PF 01353	1-1/2" x 3/4"	0.28	1	70	0.61	
PF 01351	1-1/2" x 1"	0.30	1	70	0.43	
PF 01350	1-1/2" x 1-1/4"	0.29	1	70	0.26	
PF 01364	2" x 1/2"	0.45	1	50	1.16	
PF 01362	2" x 3/4"	0.46	1	50	0.97	
PF 01360	2" x 1"	0.46	1	50	0.79	
PF 01359	2" x 1-1/4"	0.46	1	50	0.61	
PF 01358	2" x 1-1/2"	0.55	1	40	0.43	

TEE • LARGE P X P X P

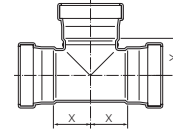

Item No.	Diameter	Approx Wt Lbs / Pc	Inner Qty Pcs / Bag	Master Qty Pcs / Box	Dimensions (in.)	
					X	Y
PF 40123	2-1/2"	2.49	1	10	1.73	1.81
PF 40152	3"	3.47	1	7	2.01	2.11
PF 40200	4"	6.15	1	4	2.58	2.68

TEE • REDUCING • SMALL P X P X P

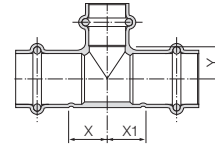

FITTING REDUCER • LARGE FTG X P

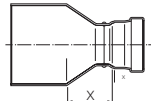

Item No.	Diameter	Approx Wt Lbs / Pc	Inner Qty Pcs / Bag	Master Qty Pcs / Box	Dimensions (in.)		
					X	X1	Y
PF 01370	2-1/2" x 1"	0.80	1	40	1.36		
PF 01369	2-1/2" x 1-1/4"	0.68	1	40	1.52		
PF 01368	2-1/2" x 1-1/2"	0.80	1	40	1.32		
PF 01367	2-1/2" x 2"	0.84	1	35	0.94		
PF 01379	3" x 1-1/4"	0.97	1	25	1.91		
PF 01378	3" x 1-1/2"	1.08	1	24	1.71		
PF 01377	3" x 2"	1.11	1	24	1.32		
PF 01376	3" x 2-1/2"	1.35	1	24	0.98		
PF 01389	4" x 2"	1.93	1	12	2.11		
PF 01388	4" x 2-1/2"	2.07	1	10	1.75		
PF 01387	4" x 3"	2.25	1	10	1.42		

Item No.	Diameter	Approx Wt Lbs / Pc	Inner Qty Pcs / Bag	Master Qty Pcs / Box	Dimensions (in.)		
					X	X1	Y
PF 04047	1/2" x 1/2" x 3/4"	0.32	10	140	0.83	0.83	0.55
PF 04067	1/2" x 1/2" x 1"	0.72	5	60	2.28	2.28	0.80
PF 04043	3/4" x 1/2" x 1/2"	0.28	10	150	0.61	0.77	0.55
PF 04041	3/4" x 1/2" x 3/4"	0.33	5	120	0.81	0.89	0.55
PF 04033	3/4" x 3/4" x 1/2"	0.29	10	140	0.61	0.61	0.55
PF 04065	3/4" x 3/4" x 1"	0.77	5	60	2.11	2.11	0.79
PF 04062	1" x 1/2" x 3/4"	0.44	5	80	0.81	1.00	0.71
PF 04061	1" x 1/2" x 1"	0.48	5	80	0.89	1.22	0.79
PF 04058	1" x 3/4" x 1/2"	0.51	5	100	0.69	0.77	0.79
PF 04056	1" x 3/4" x 3/4"	0.43	5	100	0.81	0.96	0.71
PF 04055	1" x 3/4" x 1"	0.48	5	70	0.89	1.10	0.80
PF 04051	1" x 1" x 1/2"	0.41	5	100	0.69	0.69	0.79
PF 04049	1" x 1" x 3/4"	0.45	5	80	0.81	0.81	0.71
PF 04082	1" x 1" x 1-1/4"	1.02	1	35	2.42	2.42	0.83
PF 04083	1-1/4" x 1/2" x 1-1/4"	0.81	1	40	0.96	2.66	0.83
PF 04081	1-1/4" x 3/4" x 1/2"	0.65	1	50	0.47	2.05	0.83
PF 04080	1-1/4" x 3/4" x 3/4"	0.73	1	50	0.61	2.19	0.83
PF 04079	1-1/4" x 3/4" x 1"	0.78	1	50	0.69	2.26	0.83
PF 04078	1-1/4" x 3/4" x 1-1/4"	0.85	1	40	0.96	2.54	0.83
PF 04076	1-1/4" x 1" x 1/2"	0.65	1	50	0.47	1.81	0.83
PF 04075	1-1/4" x 1" x 3/4"	0.70	1	45	0.61	1.95	0.83
PF 04074	1-1/4" x 1" x 1"	0.75	1	50	0.69	2.03	0.83
PF 04073	1-1/4" x 1" x 1-1/4"	0.84	1	40	0.96	2.30	0.83
PF 04071	1-1/4" x 1-1/4" x 1/2"	0.45	1	60	0.47	0.47	0.83
PF 04070	1-1/4" x 1-1/4" x 3/4"	0.50	1	55	0.61	0.61	0.83
PF 04069	1-1/4" x 1-1/4" x 1"	0.57	1	50	0.69	0.69	0.83
PF 40244	1-1/2" x 1/2" x 1-1/2"	1.48	1	25	1.10	3.39	1.10
PF 40238	1-1/2" x 3/4" x 3/4"	1.04	1	30	0.63	2.74	1.10
PF 04098	1-1/2" x 1" x 3/4"	1.08	1	30	0.63	2.56	1.10
PF 04097	1-1/2" x 1" x 1"	1.15	1	30	0.75	2.68	1.10
PF 04095	1-1/2" x 1" x 1-1/2"	1.46	1	25	1.10	3.03	1.10
PF 04093	1-1/2" x 1-1/4" x 3/4"	1.11	1	35	0.63	2.38	1.10
PF 04092	1-1/2" x 1-1/4" x 1"	1.18	1	30	0.75	2.50	1.10
PF 04091	1-1/2" x 1-1/4" x 1-1/4"	1.24	1	30	0.96	2.72	1.16
PF 04088	1-1/2" x 1-1/2" x 1/2"	0.75	1	40	0.47	0.47	1.08
PF 04087	1-1/2" x 1-1/2" x 3/4"	0.84	1	35	0.63	0.63	1.10
PF 04086	1-1/2" x 1-1/2" x 1"	0.92	1	35	0.75	0.75	1.10
PF 04085	1-1/2" x 1-1/2" x 1-1/4"	1.06	1	30	0.96	0.96	1.16
PF 40249	2" x 1/2" x 2"	2.11	1	15	1.30	4.11	1.34
PF 40248	2" x 3/4" x 2"	2.12	1	15	1.30	3.92	1.34

TEE • SMALL P X P X P

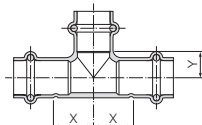

Item No.	Diameter	Approx Wt Lbs / Pc	Inner Qty Pcs / Bag	Master Qty Pcs / Box	Dimensions (in.)	
					X	Y
PF 04006	1/2"	0.21	10	200	0.67	0.49
PF 04031	3/4"	0.35	10	120	0.81	0.55
PF 04048	1"	0.51	5	70	0.89	0.79
PF 04068	1-1/4"	0.66	1	45	0.96	0.83
PF 04084	1-1/2"	1.22	1	25	1.10	1.10
PF 40102	2"	1.73	1	15	1.30	1.34

C
COPPER

PR
PRESS

PM
PLBG/MECH

TEE • REDUCING • SMALL (CONTINUED)

P X P X P

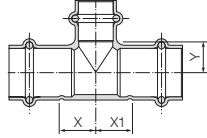

Item No.	Diameter	Approx Wt Lbs / Pc	Inner Qty Pcs / Bag	Master Qty Pcs / Box	Dimensions (in.)		
					X	X1	Y
PF 40247	2" x 1" x 1"	1.61	1	20	3.29	0.85	1.34
PF 40245	2" x 1" x 2"	2.09	1	15	1.30	3.74	1.34
PF 40117	2" x 1-1/4" x 1-1/4"	1.73	1	20	0.89	3.15	1.34
PF 40113	2" x 1-1/2" x 3/4"	1.70	1	20	0.75	2.83	1.34
PF 40112	2" x 1-1/2" x 1"	1.73	1	20	0.85	2.93	1.34
PF 40111	2" x 1-1/2" x 1-1/4"	1.83	1	20	0.89	2.97	1.34
PF 40110	2" x 1-1/2" x 1-1/2"	1.97	1	16	1.08	3.17	1.34
PF 40109	2" x 1-1/2" x 2"	2.19	1	16	1.30	3.39	1.34
PF 40107	2" x 2" x 1/2"	0.99	1	25	0.49	0.49	1.26
PF 40106	2" x 2" x 3/4"	1.20	1	25	0.75	0.75	1.34
PF 40105	2" x 2" x 1"	1.28	1	23	0.85	0.85	1.34
PF 40104	2" x 2" x 1-1/4"	1.33	1	20	0.89	0.89	1.34
PF 40103	2" x 2" x 1-1/2"	1.53	1	16	1.08	1.08	1.34

TEE • REDUCING • LARGE (CONTINUED)

P X P X P

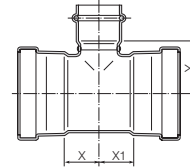

Item No.	Diameter	Approx Wt Lbs / Pc	Inner Qty Pcs / Bag	Master Qty Pcs / Box	Dimensions (in.)		
					X	X1	Y
PF 40147	3" x 3" x 1"	2.23	1	12	1.10	1.10	1.85
PF 40148	3" x 3" x 1-1/4"	2.33	1	12	1.24	1.24	2.09
PF 40149	3" x 3" x 1-1/2"	2.55	1	10	1.34	1.34	2.09
PF 40150	3" x 3" x 2"	2.75	1	10	1.61	1.61	2.09
PF 40151	3" x 3" x 2-1/2"	3.09	1	7	1.77	1.77	2.07
PF 40204	4" x 3" x 2"	6.97	1	4	5.49	1.63	2.66
PF 40206	4" x 3" x 3"	7.85	1	4	2.11	5.96	2.70
PF 40191	4" x 4" x 1/2"	3.41	1	8	0.87	0.87	2.42
PF 40192	4" x 4" x 3/4"	3.48	1	8	1.02	1.02	2.39
PF 40193	4" x 4" x 1"	3.60	1	8	1.14	1.14	2.38
PF 40194	4" x 4" x 1-1/4"	3.83	1	5	1.28	1.28	2.66
PF 40195	4" x 4" x 1-1/2"	4.00	1	6	1.38	1.38	2.66
PF 40196	4" x 4" x 2"	4.25	1	6	1.63	1.63	2.66
PF 40197	4" x 4" x 2-1/2"	4.74	1	4	1.87	1.87	2.64
PF 40198	4" x 4" x 3"	5.15	1	4	2.11	2.11	2.70

TEE • REDUCING • LARGE

P X P X P

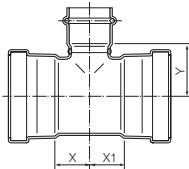

Item No.	Diameter	Approx Wt Lbs / Pc	Inner Qty Pcs / Bag	Master Qty Pcs / Box	Dimensions (in.)		
					X	X1	Y
PF 40222	2-1/2" x 3/4" x 2-1/2"	3.34	1	10	1.73	5.20	1.81
PF 40221	2-1/2" x 1" x 2-1/2"	3.33	1	10	1.73	5.06	1.81
PF 40220	2-1/2" x 1-1/4" x 2-1/2"	3.35	1	8	1.73	5.22	1.81
PF 40138	2-1/2" x 1-1/2" x 2"	3.10	1	10	1.59	4.90	1.83
PF 40137	2-1/2" x 1-1/2" x 2-1/2"	3.47	1	8	1.73	5.04	1.81
PF 40135	2-1/2" x 2" x 3/4"	2.54	1	15	0.98	3.90	1.56
PF 40134	2-1/2" x 2" x 1"	2.60	1	15	1.10	4.02	1.59
PF 40132	2-1/2" x 2" x 1-1/2"	2.89	1	12	1.34	4.29	1.83
PF 40131	2-1/2" x 2" x 2"	3.06	1	10	1.59	4.53	1.83
PF 40130	2-1/2" x 2" x 2-1/2"	3.43	1	10	1.73	4.65	1.81
PF 40129	2-1/2" x 2-1/2" x 1/2"	1.52	1	18	0.87	0.87	1.52
PF 40128	2-1/2" x 2-1/2" x 3/4"	1.64	1	18	0.98	0.98	1.56
PF 40127	2-1/2" x 2-1/2" x 1"	1.70	1	16	1.10	1.10	1.59
PF 40126	2-1/2" x 2-1/2" x 1-1/4"	1.79	1	15	1.24	1.24	1.83
PF 40125	2-1/2" x 2-1/2" x 1-1/2"	1.92	1	12	1.34	1.34	1.83
PF 40124	2-1/2" x 2-1/2" x 2"	2.13	1	12	1.59	1.59	1.83
PF 40179	3" x 3/4" x 3"	4.68	1	6	2.01	6.00	2.11
PF 40178	3" x 1" x 3"	4.68	1	7	2.01	5.81	2.11
PF 40181	3" x 1-1/4" x 3"	4.69	1	6	2.01	6.06	2.11
PF 40174	3" x 1-1/2" x 3"	4.72	1	6	2.01	5.85	2.11
PF 40164	3" x 2" x 2"	4.12	1	9	1.61	5.06	2.09
PF 40165	3" x 2" x 2-1/2"	4.38	1	8	1.77	5.22	2.07
PF 40167	3" x 2" x 3"	4.75	1	6	2.01	5.45	2.11
PF 40157	3" x 2-1/2" x 2"	4.24	1	8	4.72	1.61	2.09
PF 40158	3" x 2-1/2" x 2-1/2"	4.60	1	6	1.77	4.88	2.07
PF 40159	3" x 2-1/2" x 3"	4.95	1	6	2.01	5.12	2.11
PF 40145	3" x 3" x 1-1/2"	2.07	1	15	0.87	0.87	1.79
PF 40146	3" x 3" x 3/4"	2.14	1	12	1.00	1.00	1.80

TEE • FEMALE • SMALL

P X P X FPT

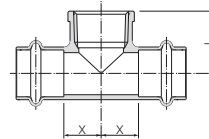

Item No.	Diameter	Approx Wt Lbs / Pc	Inner Qty Pcs / Bag	Master Qty Pcs / Box	Dimensions (in.)	
					L	X
PF 01512	1/2"	0.24	5	150	1.04	0.57
PF 01538	3/4"	0.32	5	80	1.18	0.71
PF 01569	1"	0.74	5	60	2.75	0.89
PF 01607	1-1/4"	0.94	1	40	3.04	0.96
PF 01644	1-1/2"	1.64	1	20	3.90	1.10

C
COPPER

PR
PRESS

PM
PLBG/MECH

DIMENSIONAL DATA

TEE • FEMALE • REDUCING • SMALL P X P X FPT

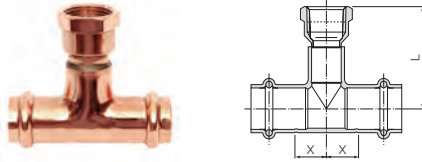

Item No.	Diameter	Approx Wt Lbs / Pc	Inner Qty Pcs / Bag	Master Qty Pcs / Box	Dimensions (in.)	
					L	X
PF 02577	3/4" x 3/4" x 1/4"	0.36	5	120	1.89	0.61
PF 01539	3/4" x 3/4" x 1/2"	0.39	5	100	1.18	0.59
PF 01570	1" x 1" x 1/2"	0.47	5	80	2.37	0.69
PF 01572	1" x 1" x 3/4"	0.60	5	70	2.61	0.81
PF 01613	1-1/4" x 1-1/4" x 1/2"	0.56	1	60	2.41	0.47
PF 02654	1-1/4" x 1-1/4" x 3/4"	0.69	1	50	2.72	0.61
PF 01645	1-1/2" x 1-1/2" x 1/2"	0.83	1	40	2.67	0.47
PF 02673	1-1/2" x 1-1/2" x 3/4"	0.95	1	35	3.00	0.63
PF 01699	2" x 2" x 1/2"	1.06	1	25	2.85	0.49
PF 02706	2" x 2" x 3/4"	1.28	1	20	3.24	0.75

UNION • SMALL P X P

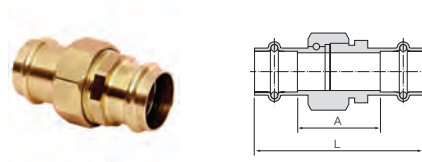

Item No.	Diameter	Approx Wt Lbs / Pc	Inner Qty Pcs / Bag	Master Qty Pcs / Box	Dimensions (in.)	
					A	L
PF 08003	1/2"	0.31	1	144	1.38	2.87
PF 08004	3/4"	0.48	1	60	1.31	3.22
PF 08005	1"	0.73	1	32	1.91	3.27
PF 11205	1-1/4"	0.93	1	28	1.92	3.27
PF 11206	1-1/2"	1.20	1	24	2.59	3.27
PF 11207	2"	1.92	1	16	2.37	3.27

TEE • FEMALE • REDUCING • LARGE P X P X FPT

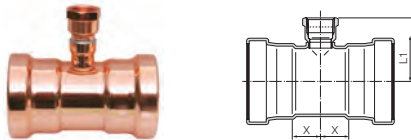

Item No.	Diameter	Approx Wt Lbs / Pc	Inner Qty Pcs / Bag	Master Qty Pcs / Box	Dimensions (in.)	
					L1	X
PF 02727	2-1/2" x 2-1/2" x 3/4"	1.67	1	18	2.37	0.98
PF 02718	3" x 3" x 3/4"	2.27	1	13	2.61	1.00
PF 02729	4" x 4" x 3/4"	3.55	1	8	3.20	1.02

UNION • FEMALE • SMALL P X FPT

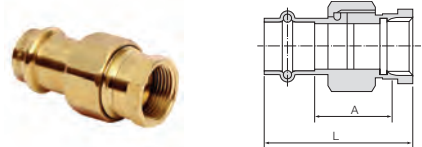

Item No.	Diameter	Approx Wt Lbs / Pc	Inner Qty Pcs / Bag	Master Qty Pcs / Box	Dimensions (in.)	
					A	L
PF 11422	1/2"	0.21	1	192	0.90	2.05
PF 11423	3/4"	0.43	1	90	0.90	2.86
PF 11424	1"	0.62	1	48	0.83	2.82
PF 11425	1-1/4"	0.84	1	28	1.20	3.06
PF 11426	1-1/2"	1.04	1	24	1.69	3.02
PF 11427	2"	1.52	1	16	1.50	3.24

UNION • DIELECTRIC P X FPT

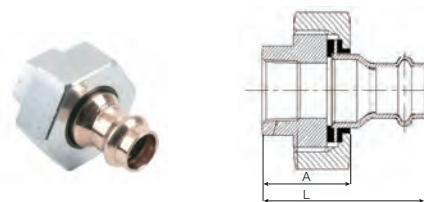

Item No.	Diameter	Approx Wt Lbs / Pc	Inner Qty Pcs / Bag	Master Qty Pcs / Box	Dimensions (in.)	
					A	L
PF 11503	1/2"	0.76	1	50	1.20	2.48
PF 11504	3/4"	0.91	1	40	1.22	2.68
PF 11505	1"	1.24	1	30	1.10	2.70
PF 11506	1-1/4"	1.23	1	30	1.20	2.91
PF 11507	1-1/2"	2.17	1	15	1.32	3.47
PF 11508	2"	2.89	1	10	1.44	3.79

UNION • MALE • SMALL P X MPT

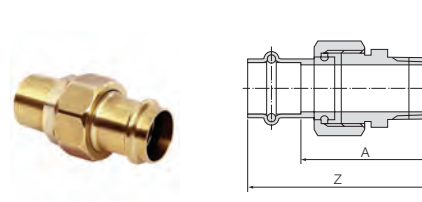

Item No.	Diameter	Approx Wt Lbs / Pc	Inner Qty Pcs / Bag	Master Qty Pcs / Box	Dimensions (in.)	
					A	Z
PF 11210	1/2"	0.28	1	144	1.67	2.78
PF 11211	3/4"	0.49	1	60	1.77	3.38
PF 11212	1"	0.77	1	32	2.20	3.76
PF 11213	1-1/4"	1.01	1	28	2.20	3.80
PF 11214	1-1/2"	1.32	1	24	2.87	3.77
PF 11215	2"	1.97	1	16	2.56	4.56

C
COPPER

PR
PRESS

PM
PLBG/MECH

FLANGE • SMALL P X FLANGE

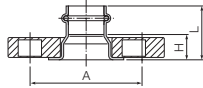

Item No.	Diameter	Approx Wt Lbs / Pc	Inner Qty Pcs / Bag	Master Qty Pcs / Box	Dimensions (in.)		
					A	H	L
PF 02933	1"	2.34	1	14	3.11	1.78	2.68
PF 03806	1-1/4"	2.94	1	14	3.50	1.80	2.82
PF 03907	1-1/2"	3.13	1	7	3.88	1.78	3.19
PF 02980	2"	4.50	1	4	4.76	1.86	3.44

SHORTCUTS™ FTG X FTG

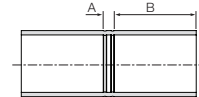

Item No.	Diameter	Approx Wt Lbs / Pc	Inner Qty Pcs / Bag	Master Qty Pcs / Box	Dimensions (in.)	
					A	B
SCO4001	1/2"	0.05	10	1000	0.125	0.839
SCO6001	3/4"	0.10	10	500	0.125	1.050
SCI0001	1"	0.13	10	100	0.125	1.010
SCI2001	1-1/4"	0.222	5	75	0.438	1.163
SCI4001	1-1/2"	0.383	5	75	0.625	1.521
SC20001	2"	0.643	5	50	0.750	1.647
SC24001	2-1/2"	0.952	1	30	0.625	1.800
SC30001	3"	1.412	1	20	0.625	1.999
SC40001	4"	2.566	1	15	0.625	2.277

FLANGE • LARGE P X FLANGE

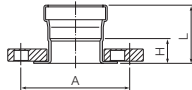

Item No.	Diameter	Approx Wt Lbs / Pc	Inner Qty Pcs / Bag	Master Qty Pcs / Box	Dimensions (in.)		
					A	H	L
PF 02746	2-1/2"	6.29	1	4	5.51	1.57	3.26
PF 02802	3"	7.53	1	3	6.30	1.38	3.23
PF 01940	4"	11.76	1	3	7.28	1.51	3.68

BALL VALVE • PRESS • SMALL P X P

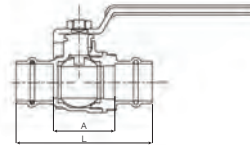

Item No.	Diameter	Approx Wt Lbs / Pc	Inner Qty Pcs / Bag	Master Qty Pcs / Box	Dimensions (in.)	
					A	L
117-723PV	1/2"	0.40	10	120	1.30	2.72
117-724PV	3/4"	0.77	10	60	1.50	3.31
117-725PV	1"	1.04	6	48	1.73	3.62
117-726PV	1-1/4"	1.52	4	24	1.93	3.98
117-727PV	1-1/2"	2.18	4	24	2.13	4.96
117-728PV	2"	4.08	2	12	2.80	5.95

FLANGE FTG X FLANGE



Item No.	Diameter	Approx Wt Lbs / Pc	Inner Qty Pcs / Bag	Master Qty Pcs / Box	Dimensions (in.)	
					A	L
PF 12980	2"	6.50	1	1	4.75	6.00
PF 12746	2-1/2"	7.40	1	1	5.50	6.00
PF 12802	3"	8.50	1	1	6.00	6.00
PF 11940	4"	12.70	1	1	7.50	6.00

BALL VALVE • PRESS • LARGE P X P

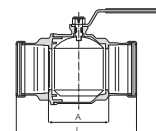

Item No.	Diameter	Approx Wt Lbs / Pc	Inner Qty Pcs / Bag	Master Qty Pcs / Box	Dimensions (in.)	
					A	L
117-729PV	2-1/2"	8.31	1	6	4.25	7.56
117-730PV	3"	12.13	1	3	4.41	8.23
117-731PV	4"	16.44	1	3	3.82	8.66

C
COPPER

PR
PRESS

PM
PLBG/MECH

INSTALLATION INSTRUCTIONS

Installer shall be qualified, licensed within the jurisdiction, and familiar with the installation of copper press systems. The following list of items are needed for the installation of Streamline® PRS Copper Press Fittings:

- Streamline® PRS Copper Press Fitting(s)
- Approved copper press tool and jaw
- Copper tube
- Tube cutter or fine tooth saw
- Deburring tools
- Half-round file
- Sand cloth
- Streamline depth gauge or ruler/other measuring device
- Permanent marker

Note: An Installation Instruction video is available on Mueller Streamline Co.'s YouTube Channel.

INSTALLATION INSTRUCTIONS – 1/2" – 2"

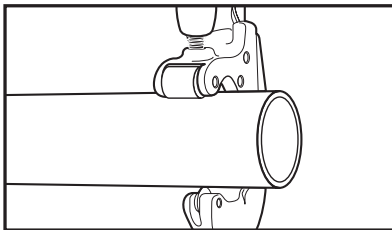

- 1** Cut tube square using a tube cutter or fine tooth saw.
- Do not use a worn or damaged tube cutter because it can damage the tube and compromise the installation.
 - Care should be taken to avoid cutting the tube in a way that puts incise marks inside the press fitting.
 - When cutting soft (annealed) tubing, do not rush or be too aggressive as this could force the tube out of round.

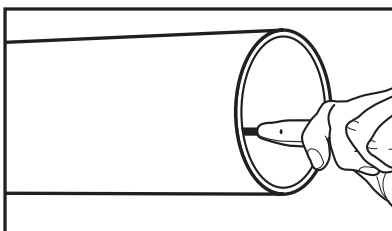

- 2** Deburr tube ID using a deburring tool.
- Use a cone tool or pen reamer to clean up internal edges, ensuring the inside diameter is smooth and free of sharp edges.

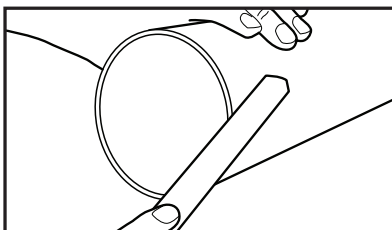

- 3** Deburr tube OD using half round file.
- Outside edges can also be deburred with a cone tool
 - It is critical to visually inspect and feel the end of the tube, as any sharp edges can damage the seals

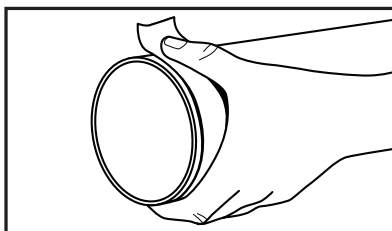

- 4** Sand tube OD with sand cloth. Tube surface should be free of indentation, scratches, & deformations.
- An abrasive pad such as Scotch-Brite™ medium-grade (maroon) can also be used
 - Any imperfections on the ends of the tube where the fitting would cover could inhibit joint integrity should be cleaned.
 - The surface of the tube end should appear bright and shiny, and scratches and other defects will be more easily recognized.
 - If tube is oval or out of round, then re-round with appropriate sizing tool.
 - If any surface or roundness issues cannot be corrected, then cut off that portion of tube and restart the process at a new piece of tube.

INSTALLATION INSTRUCTIONS CONTINUED

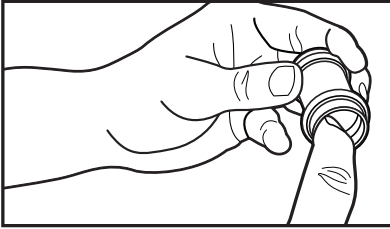

- 5** Check fitting bead to ensure seal is present. Do not use any type of oil lubrication.
- Inspect for obvious damage such as nicks or tears. If the O-ring appears to be damaged, is out of position, or missing- do not use the fitting and use a new one.
 - Fittings should remain in bag until ready to use to avoid any dirt or debris from getting in the system if possible.

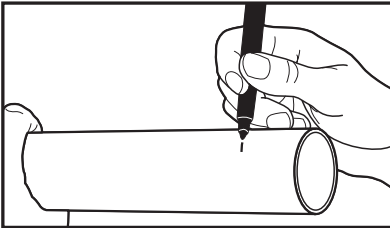

- 6** Mark tube to proper fitting insertion depth (see Insertion Depth Chart below).
- If following the insertion depth chart use a ruler or other measuring device to measure the correct insertion depth, marking with a permanent marker.

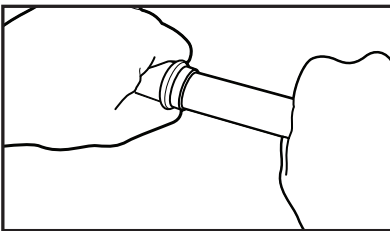

- 7** Turn slightly while sliding press fitting onto tube. Slide all the way to insertion mark & make contact with stop.
- Careful alignment of tube with fitting during insertion is critical to performance of the joint.
 - The insertion mark may go slightly into the fitting or may extend up to 1/4" beyond the end of the cup. If the insertion mark is more than 1/4" beyond the edge of the fitting, then the tube is not fully inserted.
 - If the tube is difficult to insert into the fitting, remove the fitting from the tube to make sure the seals are still seated in the groove.

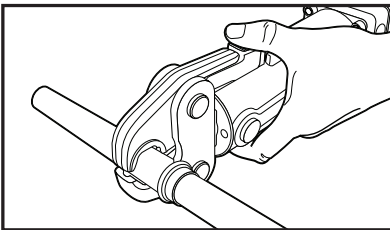

- 8** Place press tool at a right angle over fitting bead. Start the pressing process. Please see specific tool manufacturer for tool instruction.
- Inspect the jaw at the start of project and periodically during the project for build up or debris.
 - Before pressing, visually inspect that the inserted tube has remained in place and is still at the correct insertion depth as indicated by the depth mark.

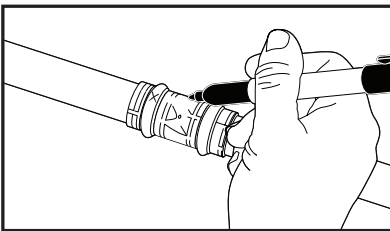

- 9** Mark joint site with an "X" once crimping process is complete to verify that the connection has been pressed.

Streamline® PRS Copper Press Fitting Insertion Depth Chart (1/2" to 2")

Tube Size (OD)	1/2"	3/4"	1"	1-1/4"	1-1/2"	2"
Insertion Depth	3/4"	7/8"	7/8"	1"	1-7/16"	1-9/16"

Streamline® PRS Copper Press Fittings must be connected with approved press tool. Please see specific tool manufacturer for tool instruction.

Streamline® PRS Copper Press Fittings Recommended Pressure Testing: Low-pressure air or water testing can be useful to assist in identifying any un-pressed connections. Leak testing with air can be dangerous at high pressures. When testing with compressed air the proper pressure range is 5 PSI to 15 PSI maximum. When testing with water the proper pressure range is 15 PSI to 50 PSI maximum. Following a successful leak test, the system may be pressure tested with air - recommended at 100 PSI up to a maximum 200 PSI - or with water - recommended at 200 PSI up to a maximum of 450 PSI - as required by local code requirements or project specifications.

INSTALLATION INSTRUCTIONS — 2-1/2" — 4"

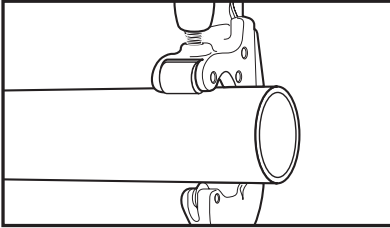

- 1** Cut tube square using a tube cutter or fine tooth saw.
- Do not use a worn or damaged tube cutter because it can damage the tube and compromise the installation.
 - Care should be taken to avoid cutting the tube in a way that puts incise marks inside the press fitting.
 - When cutting soft (annealed) tubing, do not rush or be too aggressive as this could force the tube out of round.

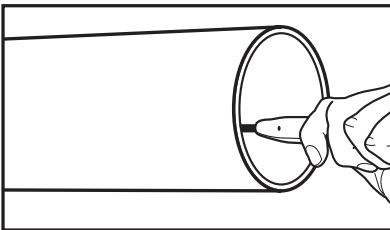

- 2** Deburr tube ID using a deburring tool.
- Use a cone tool or pen reamer to clean up internal edges, ensuring the inside diameter is smooth and free of sharp edges.

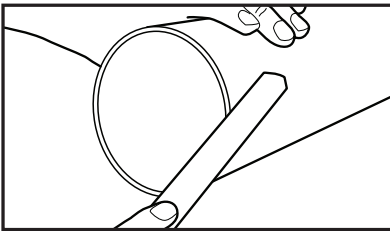

- 3** Deburr tube OD using half round file.
- Outside edges can also be deburred with a cone tool
 - It is critical to visually inspect and feel the end of the tube, as any sharp edges can damage the seals

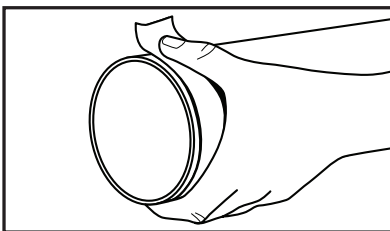

- 4** Sand tube OD with sand cloth. Tube surface should be free of indentation, scratches, & deformations.
- An abrasive pad such as Scotch-Brite™ medium-grade (maroon) can also be used
 - Any imperfections on the ends of the tube where the fitting would cover could inhibit joint integrity should be cleaned.
 - The surface of the tube end should appear bright and shiny, and scratches and other defects will be more easily recognized.
 - If tube is oval or out of round, then re-round with appropriate sizing tool.
 - If any surface or roundness issues cannot be corrected, then cut off that portion of tube and restart the process at a new piece of tube.

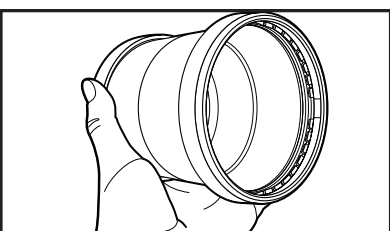

- 5** Check fitting ends to ensure seal, grip ring and nylon spacer are present. Do not use any type of oil lubrication.
- Inspect for obvious damage such as nicks or tears. If the O-ring appears to be damaged, is out of position, or missing- do not use the fitting and use a new one.
 - Fittings should remain in bag until ready to use to avoid any dirt or debris from getting in the system if possible.

INSTALLATION INSTRUCTIONS CONTINUED

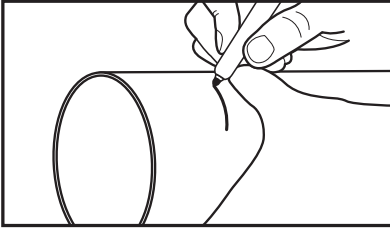

- 6** Mark tube to proper fitting insertion depth (see Insertion Depth Chart below).
- If following the insertion depth chart use a ruler or other measuring device to measure the correct insertion depth, marking with a permanent marker.

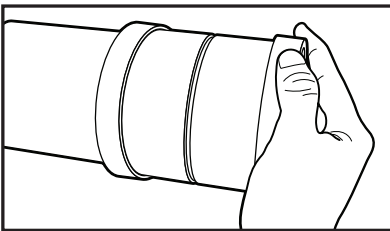

- 7** Turn slightly while sliding press fitting onto tube. Slide all the way to insertion mark & make contact with stop.
- Careful alignment of tube with fitting during insertion is critical to performance of the joint.
 - The insertion mark may go slightly into the fitting or may extend up to 1/4" beyond the end of the cup. If the insertion mark is more than 1/4" beyond the edge of the fitting, then the tube is not fully inserted.
 - If the tube is difficult to insert into the fitting, remove the fitting from the tube to make sure the seals are still seated in the groove.

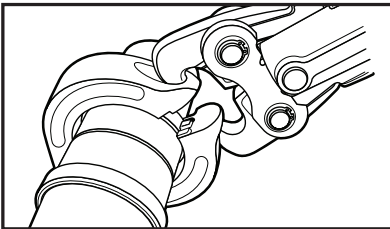

- 8** Place press-ring at a right angle over fitting bead & check for proper engagement. Start the pressing process. See specific tool manufacturer for tool instruction.
- Inspect the jaw at the start of project and periodically during the project for build up or debris.
 - Before pressing, visually inspect that the inserted tube has remained in place and is still at the correct insertion depth as indicated by the depth mark.

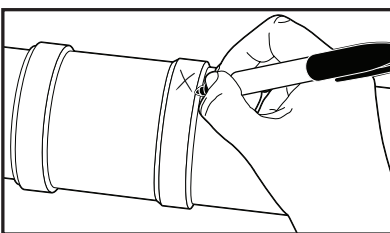

- 9** Mark joint site with an "X" once crimping process is complete to verify that the connection has been pressed.

Streamline® PRS Press Fitting Insertion Depth Chart (2-1/2" to 4")

Tube Size (OD)	2-1/2"	3"	4"
Insertion Depth	1-3/4"	1-7/8"	2-1/8"

WARNING: Failure to follow all instructions could affect joint/system integrity and may lead to property damage. Call Customer Service at **1-800-FITTING** if you have any questions or need assistance.

Streamline® PRS Copper Press Fittings must be connected with approved press tool. Please see specific tool manufacturer for tool instruction.



Large diameter (2-1/2" - 4") Streamline PRS™ fittings must be connected with approved press tool and press-rings. Please see specific tool manufacturer for tool instruction.

Streamline® PRS Copper Press Fittings Recommended Pressure Testing: Low-pressure air or water testing can be useful to assist in identifying any un-pressed connections. Leak testing with air can be dangerous at high pressures. When testing with compressed air the proper pressure range is 5 PSI to 15 PSI maximum. When testing with water the proper pressure range is 15 PSI to 50 PSI maximum. Following a successful leak test, the system may be pressure tested with air – recommended at 100 PSI up to a maximum 200 PSI – or with water – recommended at 200 PSI up to a maximum of 450 PSI – as required by local code requirements or project specifications.

TESTING AND LEAK DETECTION

PRESSURE TESTING

When installing Streamline® PRS Copper Press Fittings, it is recommended to perform a leak test in order to locate any un-pressed fittings. To assist in making that testing more reliable, Streamline® PRS Copper Press Fittings come with a leak detection feature. The following procedures assist installers in detecting un-pressed fittings in a system under pressure prior to concealment.

LEAK TESTING WITH AIR

1. When the system, or portion of the system, is installed and isolated, slowly pressurize to 15 PSI maximum using dry clean air, carbon dioxide or nitrogen charge
2. The system should stabilize over the next several hours and the pressure should be monitored with a pressure gauge.
3. If the pressure has dropped, add more pressure to bring the system back up to the 15 PSI desired initial test level. Bleed off excess pressure.
4. Allow time for complete system stabilization. If upon inspection the system pressure has dropped below 15 PSI test level, there is likely an un-pressed fitting leaking.
5. Leaks may be easily identified either by use of commercial leak test solution or soap and water mixture, which will form bubbles identifying an un-pressed leak point.
6. Once any un-pressed connection has been tested and repaired, repeat the testing process until 15 PSI pressure is maintained for 24 hours or for the duration of time and pressure specified by local authority codes.

LEAK TESTING WITH WATER

1. When the system, or portion of the system, is installed and isolated, slowly pressurize to 50 PSI maximum using clean potable water.
2. The system should stabilize over the next several hours and the pressure should be monitored with a pressure gauge.
3. If the pressure has dropped, add more pressure to bring the system back up to the 50 PSI desired initial test level. Bleed off excess pressure.
4. Allow time for complete system stabilization. If upon inspection the system pressure has dropped below 50 PSI test level, there is likely an un-pressed fitting leaking.
5. Leaks may be easily identified by leaking water.
6. Once any un-pressed connection has been tested and repaired, repeat the testing process until 50 PSI pressure is maintained for 24 hours or for the duration of time and pressure specified by local authority codes.

Once either testing procedure has been completed and verified, water/air pressure can be increased to the working pressure design of the system, not to exceed the maximum rated pressure.

The leak detection feature may assist with, but does not guarantee the detection of un-pressed connections.

TUBE SELECTION

Streamline® PRS Copper Press Fittings are designed to be joined with ASTM B88 (Types K, L, M) hard-drawn copper tube (1/2" - 4") and soft copper tube (1/2" - 1-1/4").

Copper tubing made to ASTM B88 may contain surface imperfections, which are specifically defined and allowed by the standard. This product is handled and stored multiple times before reaching the actual point of installation, potentially leading to further scratches, nicks or dents. ASTM B88 copper tube was designed for joining with solder and braze alloys – both of which are excellent gap-fill materials.

Those who specify and/or install press systems must be aware of the inherent trade-offs that accompany the decision to utilize press technology and o-ring seals. Installers should recognize surface scratches and deep incise marks (identification stamping) on the tube and avoid placing o-ring seals directly over these surface irregularities in order to reduce the risk of leaks. Sanding and cleaning the surface may or may not eliminate this concern.

STORAGE AND HANDLING

Streamline® PRS Copper Press Fittings are packaged in polybags to keep them clean and free from debris. While unlikely to be needed, the polybag also serves to keep fittings and o-ring seals together in the event that one were to be dislodged in transit. Prior to installation, it is highly recommended that a thorough visual inspection of the fittings be performed. Fittings should be handled with care and opened just prior to use, to ensure their cleanliness.

The tubing and fittings should be carefully handled during shipment and unloaded with reasonable care. Protect the stored product from moisture and dirt. Elevation above grade and away from concrete is desirable.

In the event press fittings are dropped, exercise the utmost care in visually inspecting them to assure.

TOOLS & JAWS

Installer shall be qualified and licensed within the jurisdiction, and familiar with the installation of copper press joint systems.

Streamline® PRS Copper Press Fittings shall be installed using the proper tool, jaws, actuator, and rings as instructed by the respective press fitting and press tool manufacturer.

UNDERGROUND BURIAL

Streamline® PRS fittings are approved for underground installation in accordance with the latest applicable building codes for the state and local jurisdiction. In addition, underground joints should be wrapped in 3MTM Scotchrap™ Tape 50, Shurtape® PW100 or a comparable impermeable coating system designed to protect joints from moisture, debris, corrosion and other soil stresses. When the system is embedded in concrete, tubing must be covered a minimum of 3/4" and installation must comply with IBC Section 1906.3 or UBC Section 1906.3, as applicable.

SEAL LUBRICATION

If additional seal lubrication is required, silicon or non-petroleum based lubricants must be used. Do not use any type of oil lubrication.

DIELECTRIC UNION INSTALLATION — JOINING DISSIMILAR METALS

Dielectric unions are only intended for use in the connection of copper to galvanized or bare carbon steel or other ferrous alloys as appropriate. Insulating components within the dielectric union prevent these dissimilar metals from making physical contact, which provides substantial corrosion protection. Dielectric unions are not necessary for integrating stainless steel components into copper water systems as quality stainless alloys are already compatible with copper and copper alloys. This is why stainless steel balls can be used in brass ball valves with no adverse effects. Failure to follow appropriate means for isolating dissimilar metals can lead to rapid corrosion and serious system issues.

DISTANCE BETWEEN JOINTS

Mechanical joint pressing causes some degree of deformity to the tubing. To prevent leaks, minimal distances between press joints are set forth in the table below.

TUBE DIAMETER	MINIMUM DISTANCE REQUIRED	
OD INCH	INCH	MM
1/2"	—	—
3/4"	—	—
1"	—	—
1-1/4"	7/16"	10
1-1/2"	5/8"	15
2"	3/4"	20
2-1/2"	5/8"	15
3"	5/8"	15
4"	5/8"	15

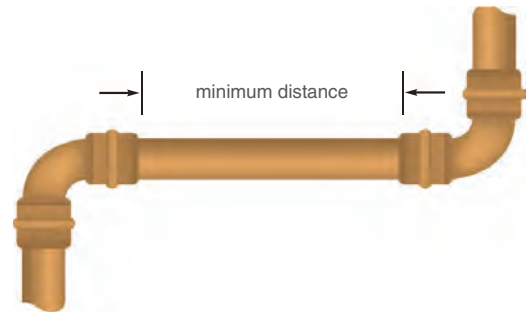

ShortCuts™ help piping system installers make faster, more economical, and more reliable press connections with minimum required spacing between joints. ShortCuts eliminate complexity and guesswork while providing installers with confidence and more uniform press connections.

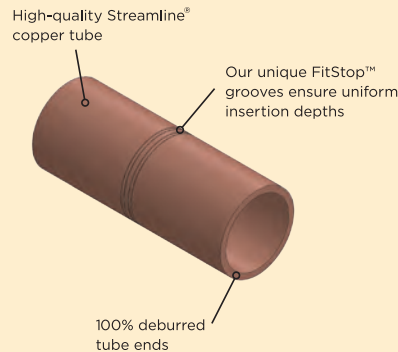



SOLDER OR BRAZING NEAR AN EXISTING PRESS CONNECTION

To ensure proper sealing of the soldered/brazed joint and the press connection, a minimum distance between the two connections must be maintained.

When soldering near a Streamline® PRS Copper Press Fittings connection, the installer must remain at least three tube diameters away from the connection to prevent damage to the sealing element of the press fitting. When brazing, the installer must remain at least nine tube diameters away from the connection. The installer should take precautions to keep the press connection cool. These methods may include 1) wrapping the press connection with a cold wet cloth, 2) fabricating solder connections prior to installing the press fitting, or 3) applying spray-type cooling gels.

TUBE DIAMETER (NOMINAL INCH)	MINIMUM DISTANCE			
	SOLDERING		BRAZING	
	INCH	MM	INCH	MM
1/2"	1-1/2"	38	4-1/2"	114
3/4"	2-1/4"	57	6-3/4"	172
1"	3"	76	9"	229
1-1/4"	3-3/4"	95	11-1/4"	286
1-1/2"	4-1/2"	114	13-1/2"	343
2"	6"	153	18"	457
2-1/2"	7-1/2"	191	22-1/2"	572
3"	9"	229	27"	686
4"	12"	305	36"	915

PRESSING NEAR AN EXISTING SOLDERED OR BRAZED CONNECTION

The minimum distance required when pressing connections near an existing brazed joint is two pipe diameters. To ensure proper sealing of both the soldered and press connections, minimum spacing between connections must be maintained. Always make sure there is no residual solder or other debris on the tubing to be inserted into the Streamline® PRS Copper Press Fittings

TUBE DIAMETER (NOMINAL INCH)	MINIMUM DISTANCE			
	SOLDERING		BRAZING	
	INCH	MM	INCH	MM
1/2"	1/4"	7	1"	25
3/4"	1/4"	7	1-1/2"	38
1"	7/16"	11	2"	51
1-1/4"	5/8"	11	2-1/2"	64
1-1/2"	3/4"	16	3"	76
2"	1/4"	19	4"	102
2-1/2"	1/4"	7	5"	127
3"	1/4"	7	6"	152
4"	1/4"	7	8"	203

PRESSING SPACE LIMITATIONS

Press tool and jaw sets can be difficult to get into some tighter spaces. In these instances it is recommended that, when possible, to preassemble product away from these space restricted areas. These assemblies can then be installed to minimize the potential for improper alignment of the pressing tools and jaws. For most press joints, use of the press tools and jaws will not pose spatial issues. The following guidelines are recommended for standard installations.

1/2" - 2" PRESSING WITH STANDARD JAWS - CLEARANCE REQUIREMENTS

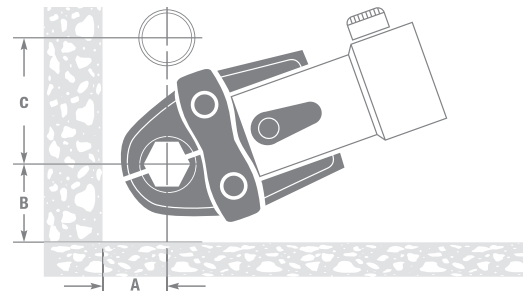
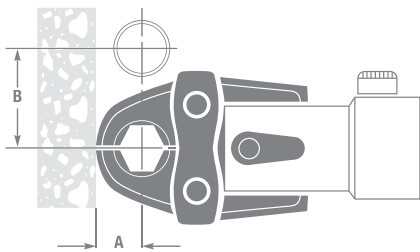

TUBE DIAMETER	A MINIMUM		B MINIMUM	
	INCH	MM	INCH	MM
1/2	3/4	19	1-5/8	41
3/4	7/8	22	2-1/8	54
1	1	26	2-1/2	64
1-1/4	1-1/8	29	2-7/8	73
1-1/2	1-3/4	45	3-1/2	89
2	2	51	4-3/8	111

TUBE DIAMETER	A MINIMUM		B MINIMUM		C MINIMUM	
	INCH	MM	INCH	MM	INCH	MM
1/2	7/8	23	1-3/8	35	2-1/2	64
3/4	1	26	1-1/2	38	2-1/2	64
1	1-1/8	29	1-3/4	45	3	76
1-1/4	1-1/4	32	2-1/4	57	3-1/8	80
1-1/2	1-7/8	48	1-1/2	64	3-3/4	95
2	2-1/8	54	3-1/8	80	5	127

1/2" - 1-1/4" PRESSING WITH COMPACT JAWS - CLEARANCE REQUIREMENTS

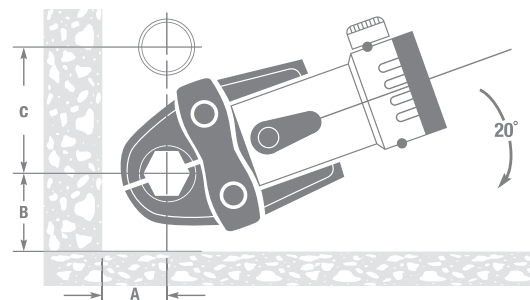
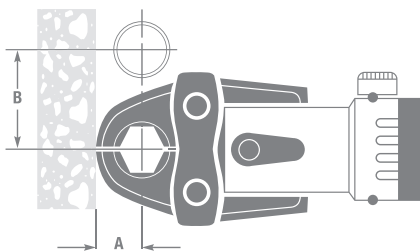

TUBE DIAMETER	A MINIMUM		B MINIMUM	
	INCH	MM	INCH	MM
1/2	3/4	19	2	51
3/4	7/8	22	2-3/8	60
1	7/8	26	2-5/8	67
1-1/4	1-1/8	28	3-1/8	85

TUBE DIAMETER	A MINIMUM		B MINIMUM		C MINIMUM	
	INCH	MM	INCH	MM	INCH	MM
1/2	7/8	23	1-3/8	35	2-1/2	64
3/4	1	26	1-1/2	38	2-3/4	70
1	1-1/8	29	1-5/8	41	3	76
1-1/4	1-5/8	39	2-1/8	53	3-3/8	85

2-1/2" – 4" PRESSING WITH PRESS RINGS – CLEARANCE REQUIREMENTS



1 Wrap the press ring around the press fitting with the opening facing away from you.

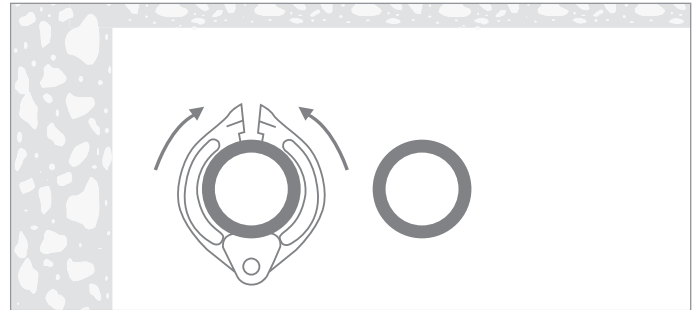

2 Close the press ring tight around the fitting

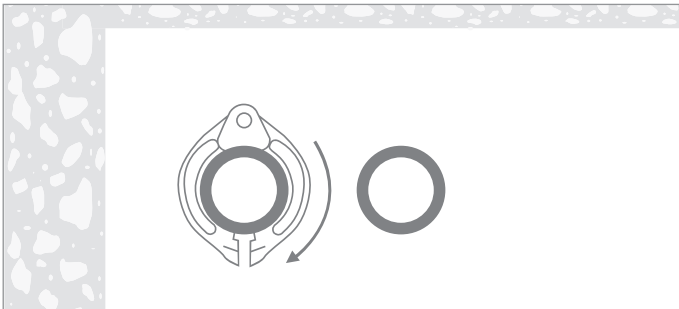

3 Rotate the press ring until the actuator jaw receptacle is facing toward you.

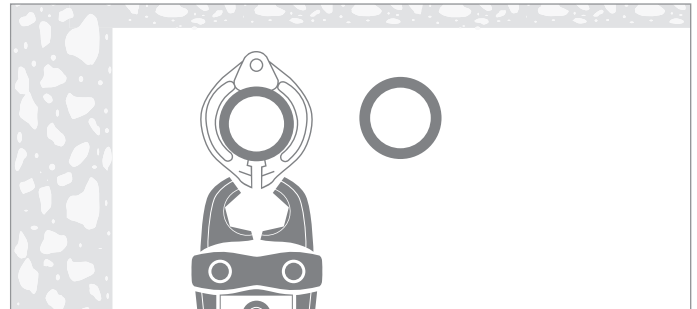

4 Properly insert actuator jaw and begin the pressing procedure.

PROCEDURE FOR LAYING THE COPPER PRESS RING AROUND THE STREAMLINE PRS FITTING WITH MINIMUM SPACE REQUIREMENTS

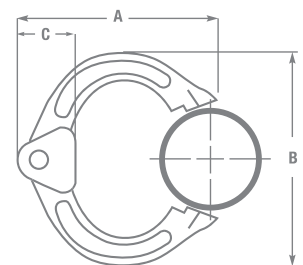
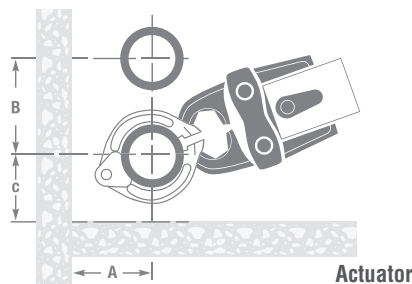
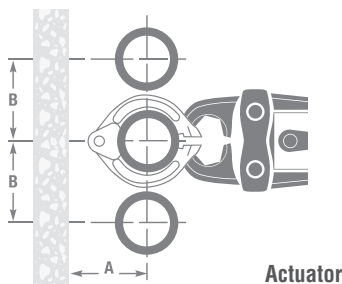

TUBE DIAMETER	A INCH (MM)	B INCH (MM)
2-1/2	4-1/8 (105)	6 (152)
3	4-3/8 (111)	7 (178)
4	5 (127)	8 (203)

TUBE DIAMETER	A INCH (MM)	B INCH (MM)	C INCH (MM)
2-1/2	4-1/8 (105)	6 (152)	4-1/2 (114)
3	4-3/8 (111)	7 (178)	4-7/8 (124)
4	5 (127)	8 (203)	5-3/4 (146)

TUBE DIAMETER	A INCH (MM)	B INCH (MM)	C INCH (MM)
2-1/2	6-3/16 (157)	6-15/16 (176)	2-7/16 (62)
3	7-7/16 (189)	8-13/16 (224)	2-7/16 (62)
4	8-1/16 (205)	10-7/16 (265)	2-7/16 (62)

-
- 1. What are Streamline® PRS Copper Press Fittings rated for regarding pressure and temperature?**
300 PSI over a temperature range of -20° F to 250° F.
 - 2. For what types of applications are Streamline® PRS Copper Press Fittings approved?**
Residential and commercial plumbing and mechanical systems.
 - 3. For what types of media are Streamline® PRS Copper Press Fittings designed?**
Hot and cold domestic water, potable drinking and cooking water, condenser and chilled water, and water glycol mixtures of ethylene or propylene glycol up to 50% at 200° F.
 - 4. What products are included in the Streamline® PRS Copper Press Fittings offering?**
Copper fittings in sizes 1/2" to 4" including couplings, elbows, tees, caps, adapters, fitting reducers, unions and flanges.
 - 5. What tubing can be used with Streamline® PRS Copper Press Fittings?**
K, L, and M hard drawn copper water tube (1/2" to 4") and soft (annealed) copper tube (1/2" to 1-1/4".)
 - 6. What is the warranty for Streamline® PRS Copper Press Fittings?**
50-year limited warranty.
 - 7. How long will the EPDM seal last in Streamline® PRS Copper Press Fittings?**
The EPDM seal carries the same warranty as the fitting in which it is installed — 50 years.
 - 8. What performance tests were performed on Streamline® PRS Copper Press Fittings?**
Certification to IAPMO PS-117 and ASME B16.51 requires the following tests: hydrostatic burst strength, unrestrained hydrostatic pressure, dynamic torque, static torque, bending, vacuum pressure, cyclic pressure, vibration and thermocycling.
 - 9. What pressing tools can be used with Streamline® PRS Copper Press Fittings?**
Most pressing tools on the market can be used, but always refer to the Tool & Jaw Compatibility information on page 6.
 - 10. Can a Streamline® PRS connection be re-crimped?** Yes. However, for 1/2" to 2" joints, the pressing jaws must be positioned on the same hex flats as the original crimp.
 - 11. Are Streamline® PRS Copper Press Fittings approved for use underground?**
Yes, in accordance with local plumbing codes.
 - 12. Are Streamline® PRS Copper Press Fittings lead free?**
Yes. They have been tested and are certified to NSF/ANSI-61 and NSF/ANSI-372.
 - 13. Are Streamline® PRS Copper Press Fittings' seals lubricated?**
The seals are lubricated as part of the manufacturing process when they are inserted into the press fittings.
 - 14. Can Streamline® PRS Copper Press Fittings be installed in a system subject to freezing?**
Care should always be taken when installing any system in severe freezing conditions. Systems exposed to freezing conditions should be protected per local plumbing codes.

15. Can Streamline® PRS Copper Press Fittings be installed in tight spaces?

Yes, as long as there is sufficient clearance around each joint to allow for the pressing tool and jaw to crimp without interference.

16. What does EPDM stand for?

Ethylene-Propylene Diene Monomer

17. How far away from a Streamline® PRS Copper Press connection can another fitting be soldered or brazed?

See Solder or Brazing Near an Existing Press Connection information on page 27.

18. How far away from a soldered or brazed joint can a Streamline® PRS Copper Press Fitting be installed?

See Pressing Near an Existing Soldered or Brazed Connection information on page 27.

19. How close together can two Streamline® PRS Copper Press Fittings connections be pressed?

See Minimum Distance Between Joints for distance between press fittings on page 26.

20. What are the most common errors made when installing a Streamline® PRS Copper Press Fittings system?

Not adequately deburring the end of the tubing, and not inserting the tube far enough into the press fitting.

21. Can Streamline® PRS Copper Press Fittings be installed in a refrigeration system?

No. The EPDM seals are not compatible with refrigerants, and the pressure rating of the system is not sufficient for many refrigerant gases.

22. How can the system be pressure tested to ensure that all fittings are pressed?

A two-stage pressure test using air and then water that is explained in detail on page 24.

23. How do I know if I missed a joint?

All Streamline® PRS Copper Press Fittings are designed with leak-before-press technology that helps identify unpressed joints.

24. Can Streamline® PRS Copper Press Fittings be painted?

Streamline® PRS fittings may be painted if desired for color identification. Proper care must be taken to avoid any oil-based paints from pooling inside the fitting ends.

25. Can Streamline® PRS Copper Press Fitting be pressed onto plastic coated tube?

Plastic coating would need to be removed to allow joint to be made on bare, prepped tube. Completed joint should be wrapped in 3M™ Scotchrap™ Tape 50, Shurtape® PW100 or a comparable impermeable coating system designed to protect joints from moisture, debris, corrosion and other soil stresses.

26. What is the recycled content in Streamline® PRS fittings?

The post-consumer recycled content is 5%. The Pre-consumer recycled content is 35%.

Streamline[®] **YOUR SYSTEM**

Streamline[®] is the preferred and specified brand of industry professionals around the world. Why? They know that since 1930, Streamline[®] products have been designed for trouble-free performance and manufactured to the highest standards. From tubing and fittings to valves and more, Streamline[®] offers a suite of quality products to support a broad range of piping systems and applications. Streamline[®] Your System, and get the confidence that only comes when a solution is designed to work together.

- Plumbing Supply Systems
- Drain, Waste, & Vent Systems
- Air Conditioning Systems
- Refrigeration Systems
- High-Pressure CO2 Systems
- Medical Gas/Oxygen Systems
- Mechanical & Steam Systems
- LP/Natural Gas Systems
- Industrial/Process Systems
- Hydronic Heating Systems
- Well & Pump Systems
- Underground Service Lines



MUELLER STREAMLINE CO.

150 Schilling Blvd, Suite 201, Collierville, TN 38017 | 1-800-FITTING | www.muellerstreamline.com

©2022 Mueller Streamline Co.