

Cement Board Construction Guide

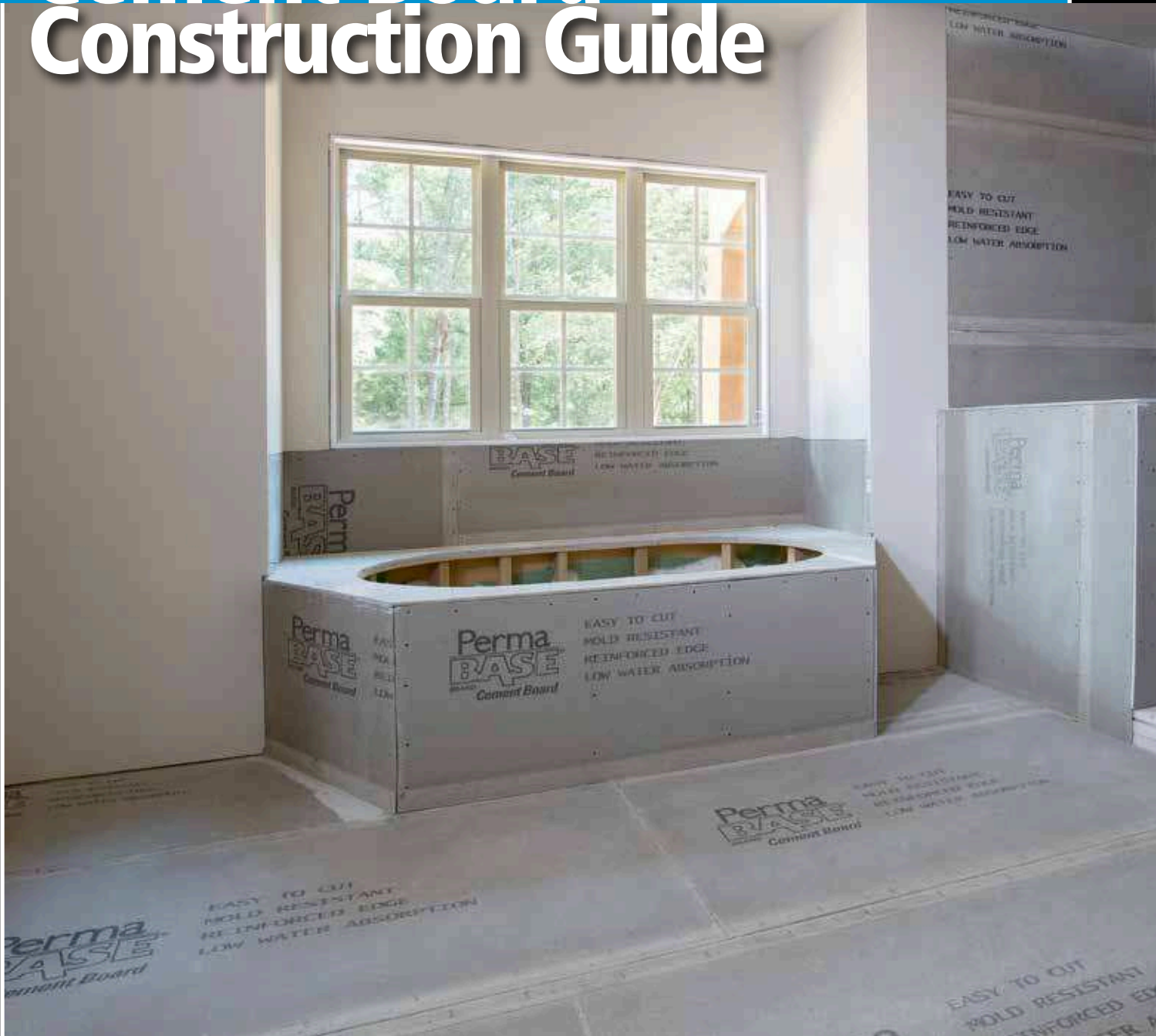

Helping You Build Better



***With* High-Quality Products and Resources**

Founded in 1925, National Gypsum is one of the world's largest producers of quality building products. For nearly a century, customers like you have looked to us for the best products, service and technical support. With a focus on sustainability, we strive to bring you the finest in construction products, education and resources to meet and exceed your expectations.



***With* Technical Support You Can Count On**

Great products are nothing without great customer service. For detailed technical information about product applications, installation requirements, code requirements or roof and wall assemblies, call 1-800-NATIONAL®. Talk directly to a technical expert with up-to-date knowledge of products, specifications, building codes and more. Our technical experts can even review your plans and drawings and get back to you with answers to your questions within 48 hours.



***With* Design That Considers The Environment**

Together, we can attain the highest level of ecological responsibility and resource-efficient technology. National Gypsum is committed to developing and implementing sustainable green building policies, standards and practices. Beyond offering products that can help contribute to healthier environments and have achieved GREENGUARD Certification for indoor air quality, we can help you meet the criteria for green programs and LEED credits.



PRODUCT
CERTIFIED FOR
LOW CHEMICAL
EMISSIONS:
UL.COM/CGG
UL 2818



Look Closer At The Best Cement Board Substrate

PermaBase® Product Line At A Glance	4
PermaBase® Cement Board.....	8
PermaBase PLUS® Cement Board.....	12
PermaBase UltraBacker® Cement Board.....	13
PermaBase Flex® Cement Board.....	14
Installation Guide How And Where	16
Interior Applications	16
Accessories	17
Exterior Applications	20
Cement Board Stucco Wall Systems (CBSS).....	22
Cement Board Masonry Veneer Wall Systems (CBMV)	23
Continuous Insulation	24
Fire-Rated Assemblies	26
Technical Data	26

Working Wherever Your Project Takes You

Choose From Four Types Of PermaBase® BRAND Cement Board:

MORE HARD-WORKING VARIETIES WITH QUALITIES YOU CAN DEPEND ON

With four types of PermaBase® BRAND Cement Board to choose from, you'll find a match for most any project. This durable substrate withstands prolonged exposure to moisture in both interior and exterior applications. Lightweight and easy to install, PermaBase promises to deliver for the long run – with the industry's best warranties. It is also GREENGUARD Certified for low chemical emissions, which can contribute to healthier indoor environments.

SAVING YOU TIME AND MONEY

These exclusive PermaBase features translate to cost savings for you: EdgeTech® Technology – This patented, reinforced edge allows fasteners to be installed closer to the board's edge and reduces damage from handling.

Polystyrene Beads – Embedded in the PermaBase core, these beads help to lighten the board's weight, improve the ease of cutting, and create lower water absorption, preventing the mortar/finish adhesive from drying prematurely.

Our PermaBase® Product Family

- 1 PermaBase® Cement Board**
The original that set the industry standard.
- 2 PermaBase PLUS® Cement Board**
Weights 25% less than other cement boards on the market.
- 3 PermaBase UltraBacker® Cement Board**
Provides excellent rigidity for special applications with the lowest water-absorption rate.
- 4 PermaBase Flex® Cement Board**
Very flexible yet strong, and ideal for use around archways, columns, stairwells – wherever an evenly curved surface is required.

APPLICATIONS

PRODUCT	FLOORS	COUNTERTOPS	WALLS	CEILINGS	EXTERIORS
1/4" PermaBase®	●	●	○	○	○
1/4" UltraBacker	●	●	○	○	○
7/16" PermaBase PLUS	●	●	●	●	●
1/2" PermaBase®	●	●	●	●	●
5/8" PermaBase®	●	●	●	●	●
1/2" PermaBase Flex	○	○	●	●	●

Recommended: ● Yes ○ No

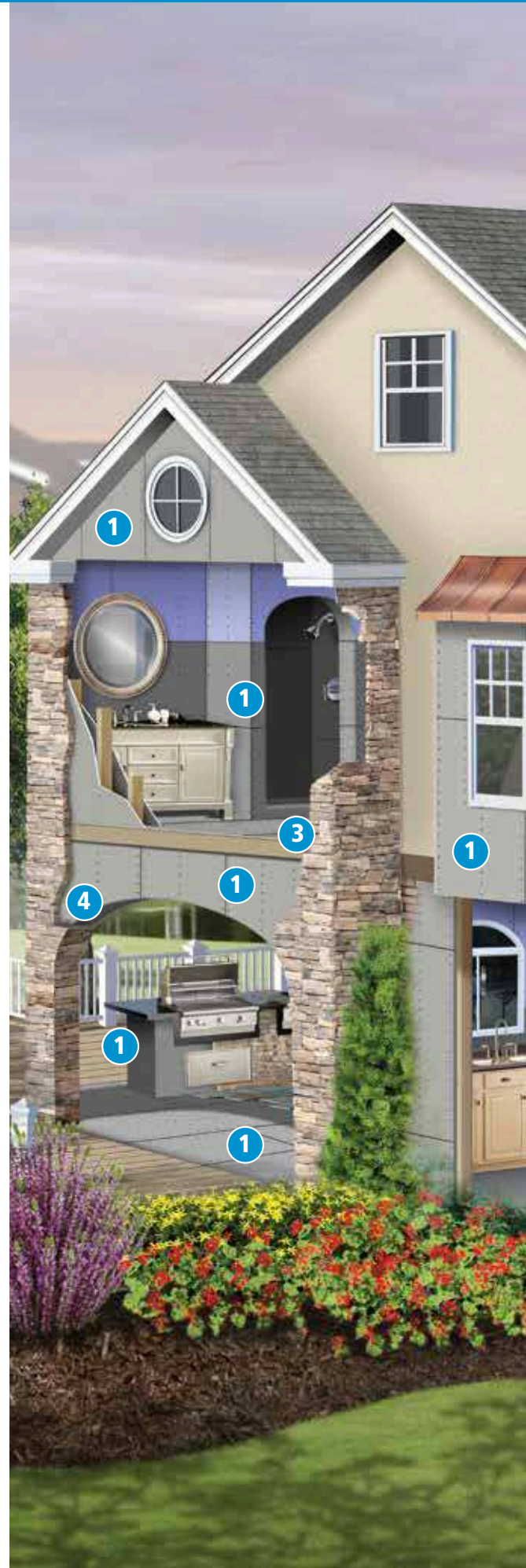



1

1

4

2

1

3

The Largest Selection with a Solution for Any Application

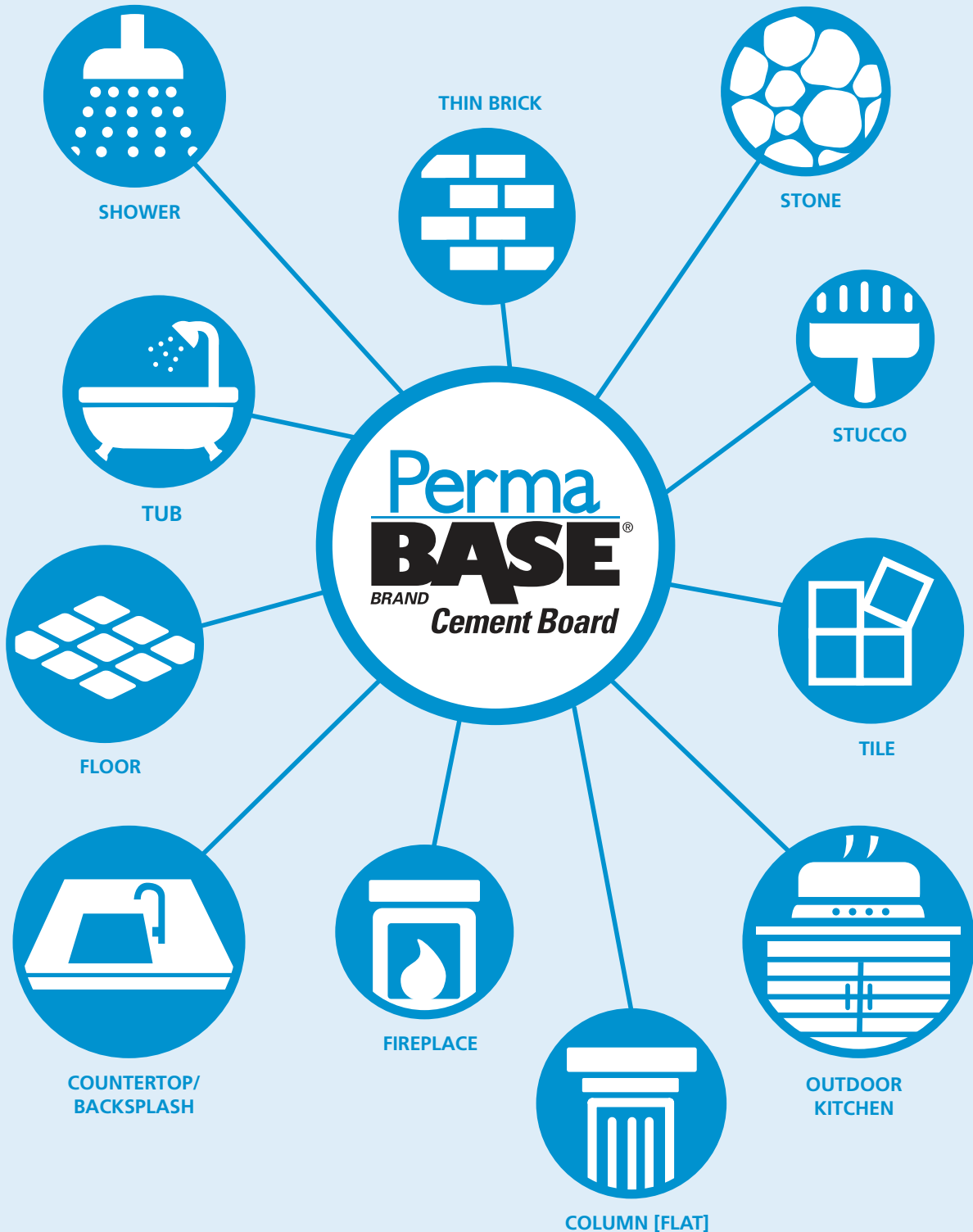

Building in Strength And Quality

Reinforce With The Best Rigid Substrate: PermaBase® BRAND Cement Board

PermaBase® provides a durable surface designed to withstand prolonged exposure to moisture. Made with Portland cement, aggregate and fiberglass mesh, it works well as an underlayment for tub and shower surrounds, countertops, flooring and a variety of other interior and exterior applications. Lightweight and easy to install, our patented EdgeTech® Technology allows a closer nail or screw application.



RESISTS MOISTURE BETTER

- Stays intact when exposed to water: will not rot, disintegrate or swell – built for the long run
- Achieves the industry's lowest water-absorption rating (ASTM C473) – offering better installation
- Helps inhibit mold growth with the highest possible score on mold tests (ASTM D3273 and ASTM G21)



STAYS STRONG AND LASTS LONG

- Resists impact and remains dimensionally stable – extending the life of your project
- Holds up to the toughest conditions



INSTALLS QUICKLY

- Lightweight and easy to cut – speeding up installation
- Reduces job site waste – easier, cleaner cut
- Patented EdgeTech® Technology allows for a closer edge fastening and reduces damage from handling



WORKS FOR INTERIOR AND EXTERIOR PROJECTS

- One panel, many applications
- Adhere tile, stone or thin brick directly to PermaBase in exterior applications – saving time and money
- Durable substrate for direct-applied coating systems
- Meets UL classifications for one- and two-hour fire-rated assemblies
- Building code approved – one substrate that does the job of many



OFFERS BEST-IN-CLASS WARRANTY

- Lifetime limited warranty: Interior applications
- 15-year limited warranty: Exterior

What Sets PermaBase® Apart From The Rest?

PHYSICAL FEATURE BENEFITS	PERMABASE® CEMENT BOARDS	OTHER CEMENT BOARDS	FIBER CEMENT BOARDS
Low-Weight Glass-Mesh Cement Board	●	○	○
Reinforced Edge	●	○	○
Fastens Near Edge With No Breakout	●	○	○
Highest Damage Resistance from Handling	●	○	○
Cleanest To Score And Snap	●	○	○
Lowest Water Absorption	●	○	○
Meets 40-psf Rating Wind-Load Test Results (Stud spacing 16" o.c.)	●	○	○
Cuts With Utility Knife Vs. Power Tools	●	●	○
Standard Fasteners Countersink Into Board	●	●	○
Can Be Used In Both Residential And Commercial Steam Rooms And Saunas	●	●	○
Inorganic Vs. Organic Core	●	●	○
Lifetime Limited Warranty For Interior Use	●	●	○
15-Year Warranty For Exterior Use	●	○	○

Product Features: ● Yes ○ No

Expanding Your Project Horizons

Dream Up Your Designs – Interior And Exterior Install Fast, Cut Costs And Improve Quality With PermaBase® BRAND Cement Board

- Stays strong – manufactured from cement and fiberglass reinforcement
- Provides consistent quality – produced in a factory-controlled environment and meets ASTM C1325
- Remains dimensionally stable
- Resists moisture and mold
- Cuts and handles easily – patented EdgeTech® Technology allows fasteners to be installed closer to the board's reinforced edge and reduces damage from handling
- Absorbs less water – providing greater open time and increased workability of adhering materials
- Offers performance enhancement options – stronger and lighter alternative to traditional methods

INTERIOR APPLICATIONS

PermaBase® is a superior underlayment for many interior applications, including:

Kitchens

- Countertops
- Backsplashes

Bathrooms

- Shower and tub enclosures
- Garden and whirlpool tubs
- Steamrooms and saunas

Special Additions

- Swimming pool and whirlpool decks and enclosures

Flooring

- For kitchens and bathrooms
- For entryways and foyers
- For laundry rooms

Walls

- For bathrooms
- For accent walls
- For fireplaces

EXTERIOR APPLICATIONS

PermaBase provides an excellent substrate for many in-demand exterior applications, including Cement Board Masonry Veneer Wall System (CBMV), Cement Board Stucco System (CBSS), Continuous Insulation (CI), and Exterior Insulation and Finish System (EIFS). PermaBase allows the combination of exterior finishes on one continuous wall sheathing, providing greater design flexibility.

- Commercial exteriors
- Residential exteriors
- Outdoor kitchens
- Decks
- Achieves GREENGUARD and GREENGUARD Gold Certification. GREENGUARD Certified products are certified to GREENGUARD standards for low chemical emissions into indoor air during product usage. For more information, visit ul.com/gg.
- Qualifies as a low-VOC-emitting material by meeting California Specification 01350. For more information, visit: calrecycle.ca.gov/greenbuilding/specs/section01350.

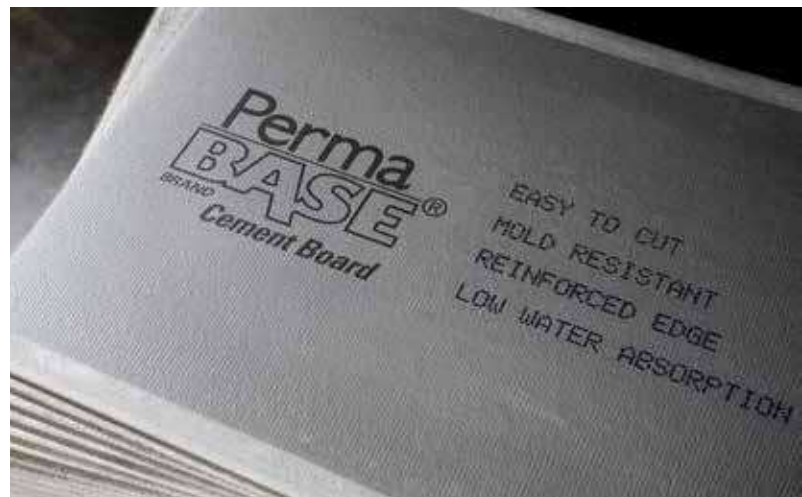

Cement Board Stucco Wall System (CBSS)

Combine the strength and durability of PermaBase® with the performance and aesthetics of reinforced base coats and textured finishes. Use in residential and low-rise commercial applications.

CEMENT BOARD STUCCO WALL SYSTEM IS DESIGNED TO:

- Provide increased impact and weather resistance (appropriate for all climates)
- Resist dirt, fading, cracking and peeling – uses 100 percent acrylic polymers
- Speed up your schedule – easier, cleaner installation than traditional stucco
- Provide drainage system to help prevent water from penetrating behind cladding in frame construction

DESIGNS YOU CAN ACHIEVE WITH THIS SYSTEM:

- Attachment of special pre-molded shapes
- Variety of finishes – many texture and color options

Note: A code-approved water/air resistive barrier (WRB) must first be installed to protect the cavity. See page 22 (Installation Guide).

Cement Board Masonry Veneer Wall System (CBMV)

Combine the strength and durability of PermaBase with the popular beauty of stone and thin brick veneers. Use in residential and low-rise commercial applications.

CEMENT BOARD MASONRY VENEER WALL SYSTEM IS DESIGNED TO:

- Offer a complete, engineered solution for installation
- Provide increased performance by utilizing polymer-modified adhesive mortars (designed for hanging materials) vs. type S and N mortars (developed for stacking materials)
- Speed up your schedule – faster, easier and cleaner than traditional metal lath/scratch-coat method
- Offer the ability to incorporate an effective water-management system (type and placement of water barrier will vary based on local codes and/or warranties)

DESIGNS YOU CAN ACHIEVE WITH THIS SYSTEM:

Use for a variety of building exteriors with manufactured or natural stone and thin brick veneers.

Note: A code-approved water/air resistive barrier (WRB) must first be installed to protect the cavity. For limitations, please see page 23 (Installation Guide).



Continuous Insulation

As building codes and building insulation requirements become increasingly stringent, you can count on PermaBase® to help meet your substrate needs for Continuous Insulation (CI). CI on the exterior envelope helps to eliminate air and moisture leakage as well as reduce thermal bridging, or the heating/cooling loss transmitted through steel studs. Methods to install the final exterior finish over the exterior insulation are now being refined, including Z-furring channels, batten strips and direct fastener applications. Use in all types of construction, including commercial, residential and multi-family.

ADVANTAGES OF CREATING CONTINUOUS INSULATION WITH PERMABASE®:

- Provides better thermal comfort, lowers heating and cooling costs, reduces likelihood of trapped moisture
- Helps mitigate the loss of heat/air conditioning by insulating the studs
- Allows multiple finishes on one substrate
- Works in all climates – adaptable to varying regional system requirements
- Guarantees 15-year exterior warranty – the industry's leading warranty
- Speeds up your schedule – faster to install than traditional method



Physical Properties

PROPERTY METHOD	TEST	1/4"	7/16" PLUS	1/2"	5/8"
Water Absorption % By Weight/24 Hours	ASTM C473	<8	<10	<8	<8
Flexural Strength (psi)	ASTM C947	>1750	750	750	>1000
Fastener Holding (Wet And Dry, lbs.) (0.400" head diameter)	ASTM D 037	>85	>90	>90	>90
Weight (psf)	ASTM C473	1.8	2.1	2.9	3.65
Freeze/Thaw (Cycles)	ASTM C666	100	100	100	100
Flame Spread/Smoke Developed	ASTM E84	0/0	0/0	0/0	0/0
Compressive Strength (psi) (Indentation)	ASTM D2394	N/A	N/A	1450	1250
Wind Load	ASTM E330	N/A	30	40	40
Thermal "R"/k Value	Property of Material	0.2/2.7	0.28/2.7	0.37/2.7	0.47/2.7
Bending Radius (ft.)	Property of Material	N/A	5	5	5
Falling Ball Impact	ASTM D1037	Pass	Pass	Pass	Pass
Linear Variation (Due to Change in Moisture Content)	ASTM D1037	<0.07%	0.05%	0.05%	0.05%
Fungus Resistance	ASTM G21	(No Growth)	(No Growth)	(No Growth)	(No Growth)
Mold Growth On Surface	ASTM D3273*	10	10	10	10
Shear Bond Strength (7 Days psi) Dry-Set Portland Cement Mortar	ANSI A118.1	N/A	N/A	204	N/A
Shear Bond Strength (7 Days psi) Latex-Portland Cement Mortar	ANSI A118.4	N/A	N/A	241	N/A
Shear Bond Strength (7 Days psi) Organic Adhesives Type 1	ANSI A136.1	N/A	N/A	159	N/A

*When tested by an independent laboratory per ASTM D3273 ("Standard Test Method for Resistance to Growth of Mold on the Surface of Interior Coatings in an Environmental Chamber"), PermaBase® achieved a panel score of 10, the highest score possible, indicating no mold growth under the laboratory test conditions. The use of PermaBase in actual installations may not produce the same results as were achieved in controlled laboratory conditions. No material can be considered "mold proof," nor is it certain that any material will resist mold indefinitely.

SIZE AND PACKAGING

SIZE: THICKNESS, WIDTH AND LENGTH **# OF PCS PER UNIT**

PERMABASE® CEMENT BOARD

1/2" x 32" x 5' (12.7 mm x 813 mm x 1524 mm)	50*
1/2" x 32" x 8' (12.7 mm x 813 mm x 2438 mm)	50
1/2" x 36" x 4' (12.7 mm x 914 mm x 1219 mm)	50*
1/2" x 36" x 5' (12.7 mm x 914 mm x 1524 mm)	50
1/2" x 36" x 6' (12.7 mm x 914 mm x 1829 mm)	50*
1/2" x 36" x 8' (12.7 mm x 914 mm x 2438 mm)	30*
1/2" x 48" x 8' (12.7 mm x 1219 mm x 2438 mm)	30
5/8" x 48" x 8' (15.9 mm x 1219 mm x 2438 mm)	24
5/8" x 36" x 5' (15.9 mm x 914 mm x 1524 mm)	35
3/8" x 36" x 5' (9.5 mm x 914 mm x 1524 mm)	50*
3/8" x 48" x 8' (9.5 mm x 1219 mm x 2438 mm)	40*
3/4" x 48" x 8' (19.0 mm x 1219 mm x 2438 mm)	20

PERMABASE® UNDERLAYMENT

1/4" x 48" x 4' (7.9 mm x 1219 mm x 1219 mm)	60
1/4" x 36" x 5' (7.9 mm x 914 mm x 1524 mm)	60

* Special Order

MORE REASONS PERMABASE® IS EXCELLENT FOR EXTERIOR APPLICATIONS

- Allows multiple finishes on one substrate
- Saves time and labor when compared with field-applied metal lath, brown and scratch-coat installations
- Works rain or shine – less affected by job site weather conditions
- Scores and snaps for quick installation
- Qualifies for multiple-year system warranties

For installation instructions and accessories, see page 16.

Lighter, Faster And Easier

When You Want The Best Lightweight Rigid Substrate: PermaBase BRAND PLUS® Cement Board

This board has the same exceptional qualities built into PermaBase® Cement Board but weighs 25 percent less. When you need to lighten your load, consider PermaBase PLUS® for all interior applications and select exterior applications, such as outdoor kitchens, grills and decks.



RESISTS MOISTURE BETTER

- Stays intact when exposed to water: will not rot, disintegrate or swell – built for the long run
- Achieves the industry's lowest water-absorption rating (ASTM C473) – offering better installation
- Helps inhibit mold growth with the highest possible score on mold tests (ASTM D3273 and ASTM G21)



STAYS STRONG AND LASTS LONG

- Resists impact and remains dimensionally stable – extending the life of your project
- Holds up to the toughest conditions



INSTALLS QUICKLY

- Lightweight and easy to cut – speeding up installation
- Reduces job site waste – easier, cleaner cut
- Patented EdgeTech® Technology allows for a closer edge fastening and reduces damage from handling



WORKS FOR INTERIOR AND EXTERIOR PROJECTS

- One panel, many applications
- Great for all interior applications, as well as exterior decks and outdoor kitchens
- Durable substrate for direct-applied coating systems
- Meets UL classifications for one- and two-hour fire-rated assemblies
- Building code approved – one substrate that does the job of many



OFFERS BEST-IN-CLASS WARRANTY

- Lifetime limited warranty: Interior applications
- 15-year limited warranty: Exterior applications

SIZE AND PACKAGING

SIZE: THICKNESS, WIDTH AND LENGTH	# OF PCS PER UNIT
7/16" x 36" x 5' (11.1 mm x 914 mm x 1524 mm)	60

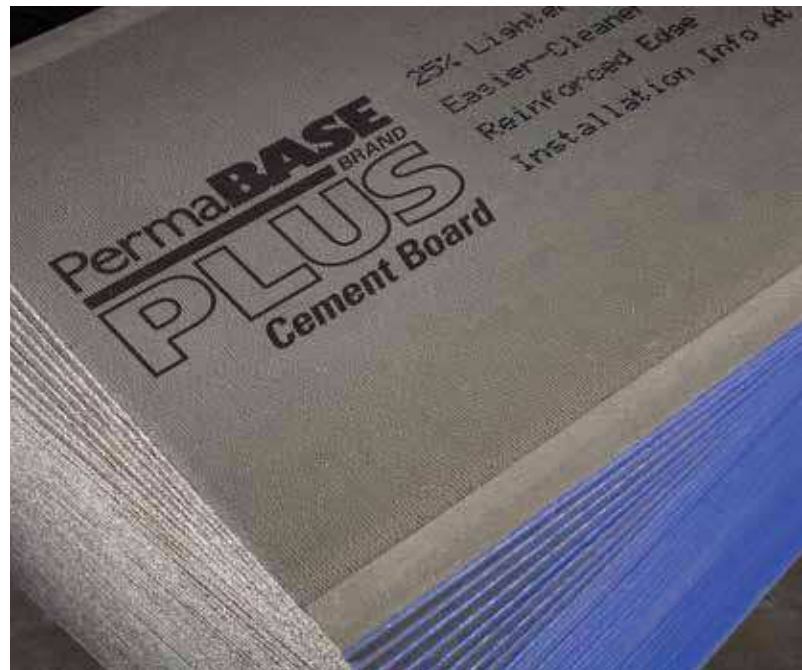

Smoother, Stronger, More Stable

When You Want The Best Rigid 1/4-Inch Underlayment That Buys You More Open Time: PermaBase[®] BRAND UltraBacker[®] Cement Board

UltraBacker[®] features a smooth mesh and mat surface. The 1/4-inch thickness eliminates the need to modify adjacent thresholds when abutting it to carpet, hardwood and other common flooring materials.



RESISTS MOISTURE BETTER THAN ANY OTHER CEMENT BOARD

- Features lowest water-absorption rating of <4% (ASTM C473) – offering better installation
- Stays intact when exposed to water: will not rot, disintegrate or swell – built for the long run
- Helps inhibit mold growth with the highest possible score on mold tests (ASTM D3273 and ASTM 21)



STAYS STRONG AND LASTS LONG

- Resists impact and remains dimensionally stable – extending the life of your project
- Holds up to the toughest conditions
- 30% stronger and four times more rigid than competitive 1/4" cement board



INSTALLS FAST AND EASY

- Can be applied over new or existing countertops or as flooring underlayment – pre-manufactured panels save you time
- Reduces job site waste – easier, cleaner cut
- Patented EdgeTech[®] Technology allows for a closer edge fastening and reduces damage from handling



OFFERS BEST-IN-CLASS WARRANTY

- Lifetime limited warranty: Interior applications

SIZE AND PACKAGING

SIZE: THICKNESS, WIDTH AND LENGTH	# OF PCS PER UNIT
1/4" x 36" x 5' (7.9 mm x 914 mm x 1524 mm)	60

Perma**BASE**
BRAND
**ULTRA
BACKER**
Cement Board



Easy To Bend, Yet Stays Strong

When You Want The Best Substrate That Bends Like No Other: PermaBase® BRAND Flex® Cement Board

This very flexible PermaBase substrate is ideal to use around archways, columns, beams or anywhere you need an evenly curved surface. Consider this also for radius shower walls, tub step-ups and stair construction – the possibilities are almost endless.



RESISTS MOISTURE BETTER

- Stays intact when exposed to water: will not rot, disintegrate or swell – built for the long run
- Achieves the industry's lowest water-absorption rating (ASTM C473) – offering better installation
- Helps inhibit mold growth with the highest possible score on mold tests (ASTM D3273 and ASTM G21)



STAYS STRONG YET FLEXES LIKE NO OTHER CEMENT BOARD

- Holds up to the toughest conditions yet bends like no other
- Resists impact and remains dimensionally stable – extending the life of your project



INSTALLS FAST AND EASY

- Pre-manufactured panels save you time
- Bends easily – 6" radius at 90°
- Reduces job site waste – easier, cleaner cut



OFFERS BEST-IN-CLASS WARRANTY

- Lifetime limited warranty: Interior applications

INSTALLATION

Installation recommendations for PermaBase Flex® are the same as for PermaBase Cement Board with this exception: framing must be spaced a maximum of 8" o.c. (See page 16 for more information.)

LIMITATIONS

PermaBase Flex has the same limitations as PermaBase with the following additions:

- For convex surfaces, PermaBase Flex must be applied with the rough surface and tapered edges exposed
- For concave surfaces, PermaBase Flex must be applied with the smooth surface exposed
- PermaBase Flex Cement Board should not be used for fire-rated assemblies
- Maximum framing spacing should not exceed 8" o.c.
- Maximum fastener spacing should not exceed 8" o.c. for wall and 6" o.c. for ceiling applications

SIZE AND PACKAGING	
SIZE: THICKNESS, WIDTH AND LENGTH	# OF PCS PER UNIT
1/2" x 36" x 6' (12.7 mm x 914 mm x 1829 mm)	25
1/2" x 48" x 8' (12.7 mm x 1219 mm x 2438 mm)	30

* Special Order

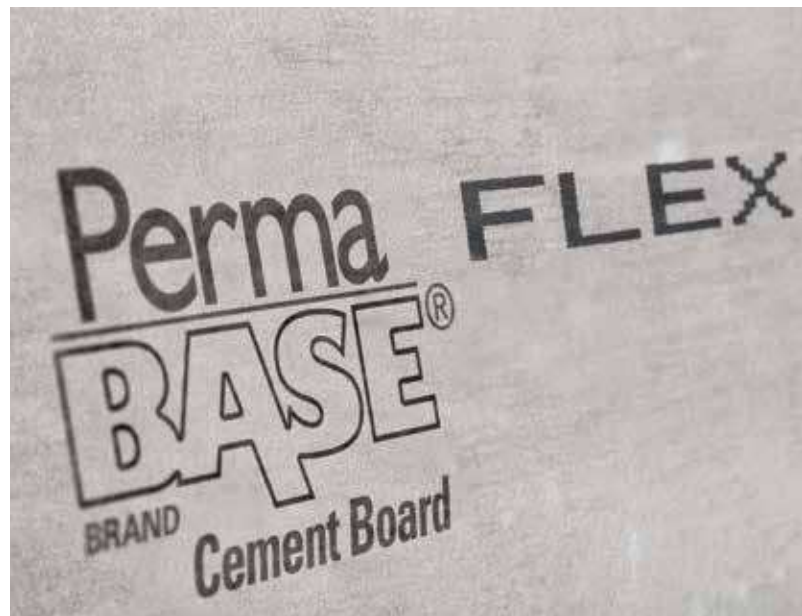

For installation instructions and accessories, see page 16.



Interior Applications

An ideal substrate for interior applications, such as:

- Shower and tub enclosures
- Garden/whirlpool tubs
- Countertops
- Backsplashes
- Steamrooms and saunas
- Swimming pool and whirlpool decks and enclosures
- Floor underlayment
- Entryways
- Kitchens
- Bathrooms
- Foyers
- Laundry rooms

INSTALLATION

General: All framing should comply with local building code requirements and be designed to provide support with a maximum allowable deflection of $L/360$ under all intended loads. Framing members should be spaced a maximum of 16" o.c. Cut or score PermaBase® on printed side of panel. Use a straightedge and pencil to mark line. Use utility knife to score/cut the glass mesh. Snap the board and cut through the now visible glass mesh on the other side. Install tile and tile setting materials in accordance with current ANSI specifications and Tile Council of North America (TCNA) guidelines.

Control Joints: For interior installations, allow a maximum of 30 lineal feet between control joints. A control joint must be installed but not limited to the following locations: where expansion joints occur in the framing or building (discontinue all cross furring members located behind joint); when boards abut dissimilar materials; where framing material changes; at changes of building shape or structural system; at each story separation. Place control joints at corners of window and door openings, or follow specifications of architect. Control joint cavity shall not be filled with coating or other materials.

WALLS AND CEILINGS

Wall Framing: Edges of PermaBase® parallel to framing should be continuously supported. Provide additional blocking when necessary to permit proper PermaBase® attachment. Do not install PermaBase® directly over protrusions from stud plane, such as heavy brackets and fastener heads. Studs above a shower floor should either be notched or furred to accommodate the thickness of the waterproof membrane or pan. The surround opening for a tub or precast shower receptor should not be more than 1/4" longer than unit to be installed.

Ceiling Framing: The deflection of the complete ceiling assembly due to dead load (including insulation, PermaBase®, bonding material and facing material) should not exceed $L/360$. The dead load applied to the ceiling frame should not exceed 10 psf. Ceiling joist or furring channel should not exceed 16" o.c. (Edges of PermaBase® parallel to framing should be continuously supported.) Provide additional blocking when necessary to permit proper PermaBase® attachment.

PermaBase® Cement Board: Apply PermaBase® with ends and edges closely butted but not forced together. Stagger ends joints in successive courses. Drive fasteners into field of cement board first, working toward ends and edges. Space fasteners maximum 8" o.c. for walls, 6" o.c. for ceilings with perimeter fasteners at least 3/8" and less than 5/8" from ends and edges. Ensure PermaBase® is tight to framing.

Joint Reinforcement: Trowel bonding material to completely fill the tapered recessed board joints and gaps between each panel. On non-tapered joints, apply a 6" wide, approx. 1/16" thick coat of bonding material over entire joint. For all joints, immediately embed 2" alkali-resistant fiberglass mesh tape fully into applied bonding material and allow it to cure. For outside corners, 4" wide mesh tape is recommended. Same bonding material should be applied to corners, control joints, trims and other accessories. Feather bonding material over fasteners to fully conceal.

INSTALLATION ACCESSORIES

For a seamless installation, we recommend PermaBase® Tape and PermaBase® Screws.

Fasteners: PermaBase® corrosion-resistant screws or equivalent, 1-1/4" or 1-5/8" long, for use with wood framing. Type S-12 screws or equivalent, 1-1/4" or 1-5/8" long, for use with 20-gauge or heavier steel framing. Galvanized roofing nails, 1-1/2" long with hot-dipped galvanized coating for use with wood framing. Nails should meet Federal Specification #FF-N105B/type 2 style 20.

Joint Reinforcement: PermaBase® mesh tape must be used on all edges and cuts made to size. Use 2" wide polymer-coated (alkali-resistant) mesh tape for interior applications and 4" wide polymer-coated (alkali-resistant) mesh tape for exterior applications.

Bonding Materials: Treat joint and set facing material, preferably with latex-Portland cement mortar or with dry-set (thin-set) mortar. All mortars should comply with ANSI A118.1, A118.4 or A118.15 standards. Type 1 organic adhesive meeting ANSI A-136.1 may be utilized for interior use only.



Shower/Tub Installation



SHOWER INSTALLATION

- | | |
|---|---------------------------------|
| 1. Support Framing 1/4" / 1/2" Slope Toward Drain | 5. Latex-Portland Cement Mortar |
| 2. Plywood, Min. 1/2" | 6. Alkali-Resistant Mesh Tape |
| 3. PermaBase® Cement Board | 7. Sealant |
| 4. Membrane | 8. Tile and Grout |



DIVIDER WALL INSTALLATION

- | | |
|----------------------------|---------------------------------|
| 1. PermaBase® Cement Board | 3. Latex-Portland Cement Mortar |
| 2. Membrane | 4. Alkali-Resistant Mesh Tape |

Installation Guide

FLOORS AND COUNTERS

Subfloor or Base: For flooring applications with 16" o.c. floor joists, 5/8" tongue-and-groove exterior-grade plywood or 3/4" tongue-and-groove exterior-grade OSB may be used. For 19.2" o.c. and 24" o.c. floor joists, 3/4" tongue-and-groove exterior-grade plywood or OSB must be used. Tile size for floors with 24" o.c. floor joists must be 12" x 12" or larger. The joist and subfloor assembly must meet L/360 as well as the appropriate code tables for live and dead loads.

Underlayment: Using a 1/4" square-notched trowel, apply a setting bed of polymer-modified mortar (or thin-set mortar) to the subfloor or counter base. Immediately laminate PermaBase® to subfloor or base leaving a 1/8" space between boards at all joints and corners. Leave a 1/4" gap along walls. Stagger all joints so that they do not line up with underlying substrate joints. Fasten PermaBase® every 8" o.c. throughout board field and around all edges while setting bed mortar is still workable. Around perimeter of each board, locate fasteners 2" from corners and not less than 3/8" from the edges. Fill all joints solid with bonding material. On non-tapered joints such as butt ends, apply a 6" wide, 1/16" thick coat over the entire joint. For all joints, immediately embed 2" fiberglass mesh tape fully into applied bonding material; ensure that tape is centered over joint. Apply bonding material over fasteners to fully conceal. Remove all excess bonding material and allow to cure.

LIMITATIONS

- Joints should be treated with alkali-resistant fiberglass mesh tape set in a polymer-modified mortar
- Conventional paper drywall tape, joint compound and drywall nails or screws should not be used
- Maximum wall framing spacing should not exceed 16" o.c. and must be designed to limit deflection to L/360 under all live and dead loads
- Steel framing must be 20 gauge (galvanized) or heavier – 16" o.c.
- 1/4" PermaBase® and 1/4" UltraBacker® should not be used on walls or ceilings
- PermaBase® is not a water barrier; consult local building code for moisture barrier requirements
- Not recommended for use under vinyl flooring
- For exterior and interior finishes applied directly to PermaBase®, reinforcing mesh must be embedded in base coat; consult finish manufacturer for additional requirements
- PermaBase® should not be exposed to temperatures over 220°F (105°C)
- PermaBase® is not a nailing base for other finishes

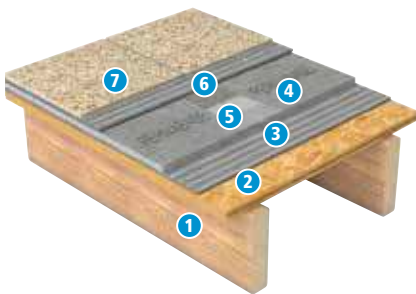

FLOOR UNDERLAYMENT

1. Joists
2. Subfloor
3. Dry-Set Mortar
4. PermaBase® Cement Board
5. Fiberglass Mesh Tape (Alkali Resistant)
6. Dry-Set Mortar
7. Tile

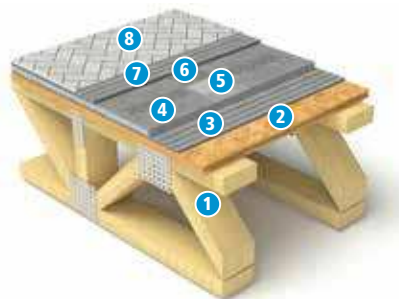

FLOOR UNDERLAYMENT

1. Open-Web Wood Trusses
2. Subfloor
3. Dry-Set Mortar
4. PermaBase®
5. Mesh Tape
6. Dry-Set Mortar
7. Mortar Bed
8. Tile



COUNTERTOP INSTALLATION

1. OSB/plywood
2. Dry-Set Mortar
3. PermaBase® Cement Board
4. Fiberglass Mesh Tape (Alkali-Resistant) Embedded in Mortar
5. Dry-Set Mortar
6. Tile

Fastener Spacing



1. Ceilings - Fasten PermaBase a maximum of every 6" o.c. into existing ceiling framing.
2. Walls - Fasten PermaBase a maximum of every 8" o.c. into existing wall framing.
3. Floors - Fasten PermaBase a maximum of every 8" o.c. throughout board field and around all edges.

Exterior Applications

An ideal substrate for exterior applications, such as:

- Tile applications
- Stucco applications
- Cement board stucco
- Thin brick
- Adhered stone veneer
- Thin porcelain tile
- Ventilated rainscreen facade
- EIFS
- Continuous Insulation
- Outdoor kitchens/grills

INSTALLATION

General: All framing should comply with local building code requirements and be designed to provide support with a maximum allowable deflection of $L/360$ under all intended live (including wind) and dead loads.

Note: Cut or score PermaBase® on rough side of panel.

Control Joints: For exterior installations, allow a maximum of 16 lineal feet between control joints. Consult finish manufacturer for other requirements. For exterior tile applications, control joints should be spaced a maximum of every 12'. A control joint must be installed but not limited to the following locations: where expansion joints occur in the framing or building (discontinue all cross furring members located behind joint); when boards abut dissimilar materials; where framing material changes; at changes of building shape or structural system; at each story separation. Place control joints at corners of window and door openings, or follow specifications of architect. Control joint cavity shall not be filled with coating or other materials.

WALLS AND CEILINGS

Wall Framing: Studs should be spaced a maximum of 16" o.c. Edges/ends of PermaBase® parallel to framing should be continuously supported. Provide additional blocking when necessary to permit proper PermaBase attachment. Do not install PermaBase® directly over protrusions from stud plane such as heavy brackets or fastener heads.

Ceiling Framing: The deflection of the complete ceiling assembly due to dead load (including insulation, PermaBase®, bonding material and facing material) should not exceed $L/360$. The dead load applied to the ceiling frame should not exceed 10 psf. Ceiling joist or furring channel should not exceed 16" o.c. (Edges of PermaBase® parallel to framing should be continuously supported.) Provide additional blocking when necessary to permit proper PermaBase® attachment.

Water Barrier: While PermaBase® is unaffected by moisture, a water/air resistive barrier (WRB) must be installed to protect the cavity. The type and specific placement or location of the water barrier will vary based on local building codes and/or manufacturers' warranties. Consult the WRB manufacturer's recommendations for specific installation guidelines.

PermaBase® Cement Board: Apply PermaBase® with ends and edges closely butted but not forced together. Stagger end joints in successive courses. Drive fasteners into field of cement board first, working toward ends and edges. Space fasteners maximum 8" o.c. for walls, 6" o.c. for ceilings with perimeter fasteners at least $3/8$ " and less than $5/8$ " from ends and edges.

Joint Reinforcement: Trowel bonding material to completely fill the tapered recessed board joints and gaps between each panel. On non-tapered joints, apply a 6" wide, approximately $1/16$ " thick coat of bonding material over entire joint. For all joints, immediately embed 4" alkali-resistant fiberglass mesh tape fully into applied bonding material and allow to cure. Same bonding material should be applied to corners, control joints, trims or other accessories. Feather bonding material over fasteners to fully conceal.

DECKS

Subfloor: Plywood should be securely glued and fastened to floor joists spaced a maximum of 16" o.c. Subfloor should be sloped at a minimum pitch of 1/4" per foot. The floor surface should be true to plane within 1/8" in 10'.

Underlayment: Using a 1/4" square-notched trowel, apply a setting bed of latex-portland cement mortar to the subfloor. Immediately laminate UltraBacker® to subfloor, leaving a 1/8" space between boards at all joints and corners. Leave a 1/4" gap along walls. Stagger joints so they do not line up with underlying substrate joints. Fasten UltraBacker every 8" o.c. throughout board field and around all edges while setting bed mortar is still workable. Around perimeter of each board, locate fasteners 2" from the corners and not less than 3/8" from the edges. Fill all joints solid with bonding material. On non-tapered joints such as butt ends, apply a 6" wide, 1/16" thick coat over the entire joint. For all joints, embed alkali-resistant fiberglass mesh tape fully into applied bonding material; ensure that tape is centered over joint. Apply bonding material over fasteners to fully conceal. Remove all excess bonding material and allow it to cure.

Waterproof Membrane: Trowel apply waterproof membrane to the entire surface of the cement board, following membrane manufacturer's installation instructions in detail.



Installation Guide

Cement Board Stucco Wall Systems (CBSS)

For use in residential and low-rise commercial applications, CBSS provides a drainage system to help prevent water from penetrating behind cladding in framed construction. It complies with ASTM D226, protecting approved sheathings/structural components and helping to evacuate incidental water.

BENEFITS INCLUDE

- Appropriate for all climates and resists the growth of mold and mildew
- Extremely durable with increased resistance to impact and inclement weather
- Acrylic polymers provide more resistance to fading, cracking and peeling
- Engineered system that allows a faster installation while providing superior quality control (manufactured product that must comply with ASTM product specifications)
- Provides a 15-year exterior warranty – the industry's best

LIMITATIONS

- Follow finish material manufacturer's instructions for proper installation
- Treat joints in PermaBase® with mesh tape and base coat
- Thin veneer construction can reveal planar irregularities in framing
- Minor cracking at joints may become visible in finished exterior surface
- Exterior finishes applied directly to PermaBase®: Reinforcing mesh must be embedded in base coat (consult exterior finish manufacturer for additional installation requirements)
- Conventional Portland cement plaster systems: Self-furring metal lath must be used over PermaBase® and fastened to studs
- Code-approved water/air resistive barrier (WRB) must first be installed to protect the cavity (type and placement will vary per local building codes and/or manufacturer's specifications, installation guidelines and warranties)

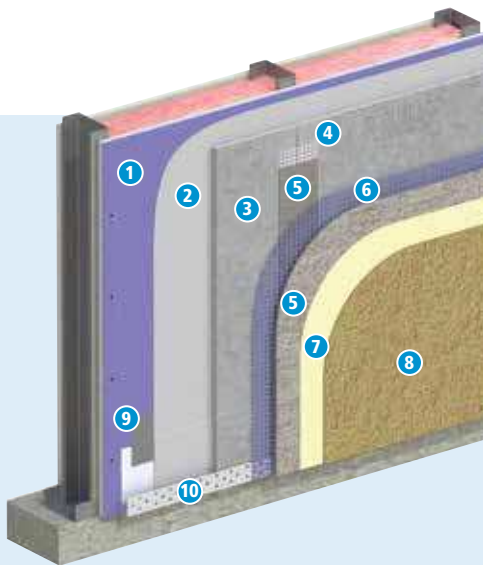

CEMENT BOARD STUCCO

- | | |
|------------------------------|---------------------|
| 1. eXP® Sheathing | 6. Reinforcing Mesh |
| 2. Weather Resistant Barrier | 7. Primer |
| 3. PermaBase® Cement Board | 8. Finish Coat |
| 4. Mesh Tape | 9. Flashing Tape |
| 5. Base Coat | 10. Weep Screed |

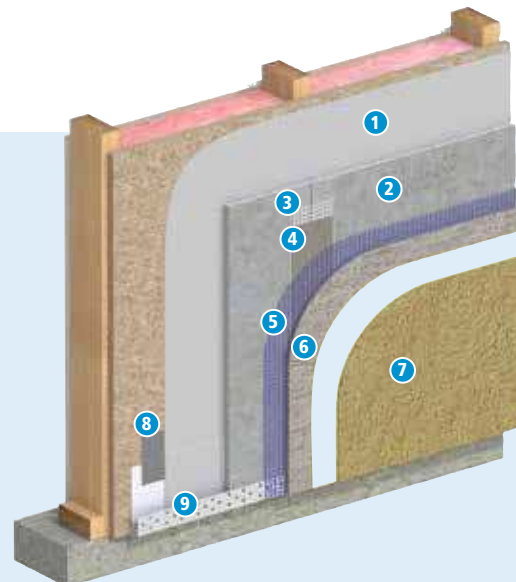

WOOD STUD STUCCO

- | | |
|------------------------------|----------------|
| 1. Weather Resistant Barrier | 6. Base Coat |
| 2. PermaBase® | 7. Finish Coat |
| 3. Mesh Tape | 8. Flashing |
| 4. Base Coat | 9. Weep Screed |
| 5. Reinforcing Mesh | |

Cement Board Masonry Veneer Wall System (CBMV)

For use in residential and low-rise commercial applications, CBMV offers a complete, engineered solution for installation of adhered veneers. It provides the ability to incorporate an effective water-management system for a variety of building exteriors with manufactured or natural stone and thin brick veneers.

BENEFITS INCLUDE

- Engineered system that allows a faster installation while providing superior quality control (manufactured product that must comply with ASTM product specifications)
- Increased performance by utilizing modified adhesive mortars (designed for hanging materials) rather than type S&N mortars (developed for stacking materials)
- Extremely durable with increased resistance to impact and inclement weather
- Approved for use in ASTM 1780, and cement board is cited as an approved substrate for this system by the Masonry Veneer Manufacturers Association (MVMA): *Installation Guide and Detailing Options for Compliance with ASTM C1780*
- Easily allows for the inclusion of continuous installation into the assembly
- Appropriate for all climates, and resists the growth of mold and mildew
- Speed up your schedule – faster, easier and cleaner than traditional metal lath/scratch-coat method

- IBC/IRC compliant; meets ASTM C1325
- PermaBase® is approved as a substrate for direct applied finishes, tile, stone and thin brick in exterior applications, as outlined in UL Evaluation Report ER-22158
- PermaBase® is suitable for use in combustible and noncombustible construction under the IBC and IRC, as outlined in UL Evaluation Report ER-22158

LIMITATIONS

- Sheathing selection and installation varies according to type of wall construction
- Code-approved water/air resistive barrier (WRB) must be installed to protect the cavity (type and placement will vary per local building codes and/or manufacturer's specifications, installation guidelines and warranties)

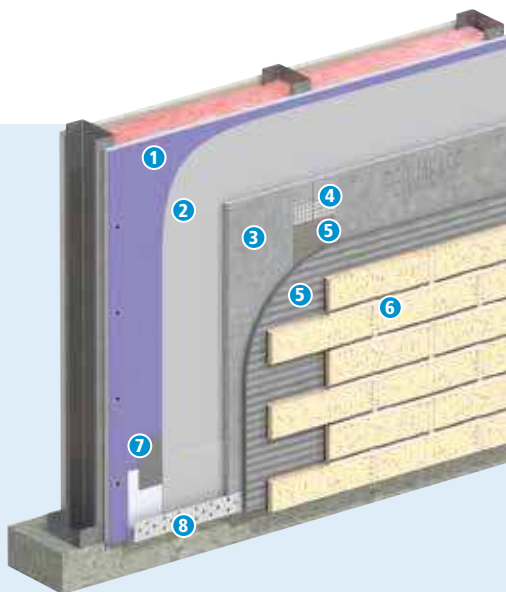

Cement Board Masonry Veneer–Thin Brick

- | | |
|------------------------------|----------------------|
| 1. eXP® Sheathing | 5. Mortar |
| 2. Weather Resistant Barrier | 6. Thin Brick Veneer |
| 3. PermaBase® Cement Board | 7. Flashing Tape |
| 4. Mesh Tape | 8. Weep Screed |

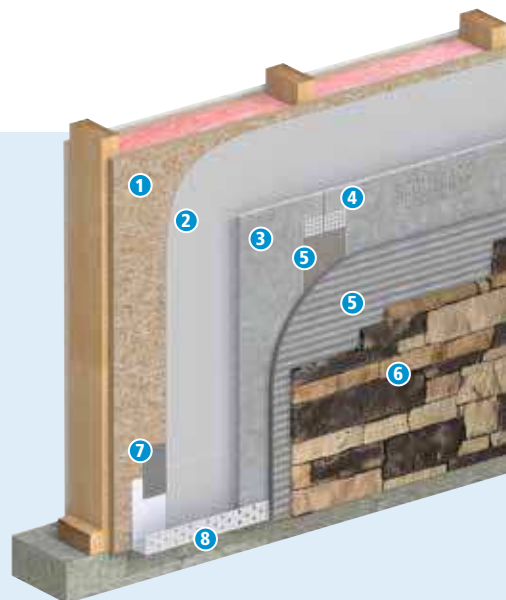

Cement Board Masonry Veneer – Stone

- | | |
|------------------------------|----------------------|
| 1. Sheathing | 6. Thin Stone Veneer |
| 2. Weather Resistant Barrier | 7. Flashing Tape |
| 3. PermaBase® Cement Board | 8. Weep Screed |
| 4. Mesh Tape | |
| 5. Mortar | |

Installation Guide

Continuous Insulation

For use in residential and low-rise commercial applications, Continuous Insulation offers a complete, engineered solution for required structural performance. Including PermaBase® as a component in this system reinforces the building and provides the ability to incorporate an effective water-management system.

BENEFITS INCLUDE

- Engineered system that allows a faster installation while providing superior quality control (manufactured product that must comply with ASTM product specifications)
- Helps mitigate the loss of heat/air conditioning by insulating the studs (reduces thermal bridging)
- Helps eliminate air and moisture leakage
- Appropriate for all climates, resists the growth of mold and mildew, and offers fire protection
- Provides added dimensional stability
- Helps prevent the water/air resistive barrier (WRB) from being compromised as assembly components shift
- Provides a 15-year exterior warranty – the industry's best

LIMITATIONS

- Sheathing selection and installation varies according to type of wall construction
- Code-approved water/air resistive barrier (WRB) must first be installed (type and placement will vary per local building codes and/or manufacturer's specifications, installation guidelines and warranties)

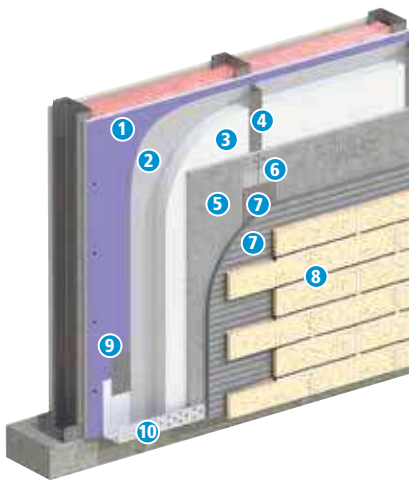

Continuous Insulation– Z Furring–Installation

1. eXP® Sheathing
2. Weather Resistant Barrier
3. Insulation
4. Z-Furring
5. PermaBase® Cement Board
6. Mesh Tape
7. Mortar
8. Thin Brick Veneer
9. Flashing Tape
10. Weep Screed

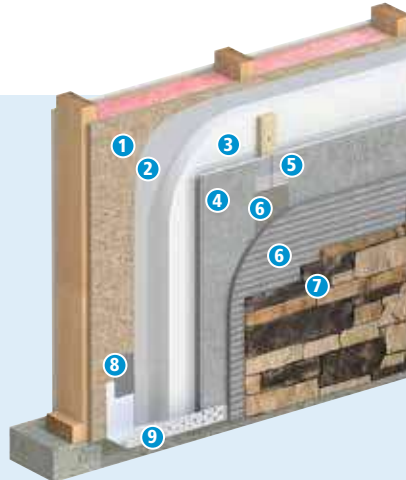

Continuous Insulation– Batten Strip

1. Sheathing
2. Weather Resistant Barrier
3. Insulation
4. PermaBase® Cement Board
5. Mesh Tape
6. Mortar
7. Thin Stone Veneer
8. Flashing Tape
9. Weep Screed

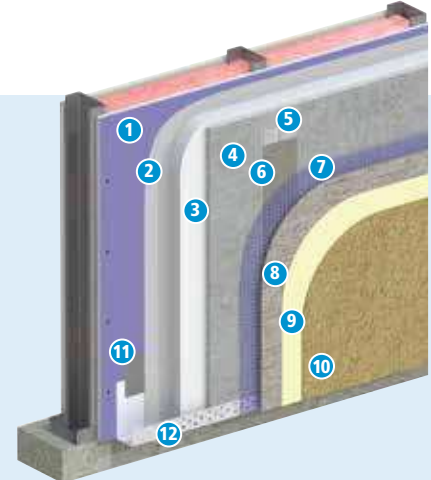

Continuous Insulation– Specialty Fastener

1. eXP® Sheathing
2. Weather Resistant Barrier
3. Insulation
4. PermaBase® Cement Board
5. Mesh Tape
6. Base Coat
7. Mesh
8. Base Coat
9. Primer
10. Finish Coat
11. Flashing Tape
12. Weep Screed

This section of the PermaBase Construction Guide provides information on how to utilize PermaBase within both a CBMV System and a Continuous Insulation System. While some typical examples are shown (right) for reference purposes, the specifications and details on how to design and construct individual systems should be obtained from the adhering material or veneer manufacturer of the materials that are being used to complete the system. For more information, go to permabase.com/exteriors.

Heat Shield Installation



Note: Do not put screws in projected appliance area of the heat shield.

1. Studs Spaced 16 in. o.c.
2. Existing Gypsum Board
3. Two Layers 4 in. Wide Furring Strips
4. PermaBase® Heat Shield
5. Joint Treatment
6. Fasteners Spaced 8 in. o.c. Maximum
7. 1/2 in. Minimum Clearance from the Floor

PermaBase® heat shielding permits clearance reduction up to 40 percent of the manufacturer's suggested clearance.

WALL PROTECTOR/HEAT SHIELD

1/2" PermaBase® and 7/16" PermaBase PLUS® are listed by Underwriters Laboratories, Inc., for use with UL-listed solid-fuel room heaters and fireplace stoves. Used as a wall protector/heat shield, PermaBase Cement Board reduces by 40 percent the manufacturer-specified clearance (minimum 12 in. [305 mm]) between the room heater or stove and a combustible wall surface.

Installation: Furring is made by cutting a full PermaBase® panel into 4 in. (102 mm) wide strips with a carbide-tipped saw or utility knife. Attach a double layer of furring strips to the wall studs using cement board screws, which provide a minimum penetration of 3/4 in. (19.1 mm) into the framing.

When installing panels, leave a 3 in. (76.2 mm) gap at the ceiling and 1 in. (25.4 mm) to 2 in. (50.8 mm) gap at the floor. This air space is required for the proper functioning of the heat shield. Do not close or block these openings.

Heat shield panels may be cut to required size using a standard utility knife or power saw. Fasten the PermaBase® panels to the studs with galvanized roofing nails or cement board screws spaced 8 in. (203 mm) o.c. Cement board screws must be long enough to penetrate into framing a minimum of 3/4 in. (19.1 mm). Do not install any nails or screws into the wall area directly behind the proposed location of the appliance.

Finishing: Prefill joints with latex-fortified Portland cement mortar, then immediately embed PermaBase® Tape and level joints. As an alternative, apply PermaBase® Tape over the joints, then apply latex-fortified Portland cement mortar, forcing it through the tape to completely fill and level the joints. All non-combustible finishes, such as ceramic tile, thin brick or stone, can be applied over wall-shield.

Do not apply combustible finishes, such as wallpaper, to cement board surface.

Fire-Rated Wall Assemblies

PermaBase® Cement Board has been tested and/or approved for use in a variety of fire-rated wall systems.

UL LISTED PERMABASE® CEMENT BOARD PARTITIONS – STEEL FRAMING

1-hour Fire Rating
V452 UL Design



7/16" PermaBase® PLUS or 1/2" PermaBase applied vertically or horizontally to one side of 3-5/8" steel studs 16" o.c. 5/8" Fire-Shield Gypsum Board applied vertically to opposite side. 3" mineral wool insulation in stud cavities.

1-hour Fire Rating
U425 UL Design



7/16" PermaBase® PLUS or 1/2" PermaBase applied vertically or horizontally over 5/8" Fire-Shield Gypsum Board applied vertically to each side of 3-1/2", 20-gauge steel studs 16" o.c. PermaBase secured to studs with cement board screws of adequate length to penetrate studs 3/8" spaced 8" o.c.

1-hour Fire Rating
V438 UL Design



7/16" PermaBase® PLUS or 1/2" PermaBase applied vertically or horizontally over 5/8" Fire-Shield Gypsum Board applied vertically to each side of 3-5/8" steel studs 16" o.c. PermaBase secured to studs with cement board screws of adequate length to penetrate studs 3/8" spaced 8" o.c.

2-hour Fire Rating
V452 UL Design



7/16" PermaBase® PLUS or 1/2" PermaBase applied vertically over 1/2" Fire-Shield C or 5/8" Fire-Shield Gypsum Board, applied vertically to one side of 3-5/8" steel studs 16" o.c. 2 layers 1/2" Fire-Shield C or 7-5/8" Fire-Shield Gypsum Board applied vertically to opposite side. 3" mineral wool insulation in stud cavities.

1-hour Fire Rating
V452 UL Design



7/16" PermaBase® PLUS or 1/2" PermaBase applied vertically or horizontally to one side of double row of 3-5/8" steel studs 16" o.c. 5/8" Fire-Shield Gypsum Board applied vertically to opposite side. 3" mineral wool insulation in stud cavities.

2-hour Fire Rating
V438 UL Design

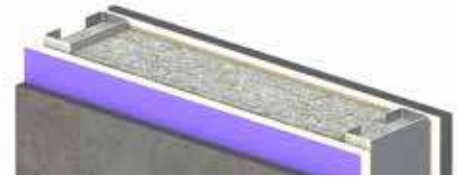

7/16" PermaBase® PLUS or 1/2" PermaBase applied horizontally or vertically over 1/2" Fire-Shield Cor or 5/8" Fire-Shield Gypsum Board, applied vertically to each side of 3-5/8" steel studs 16" o.c. 3" mineral wool insulation in stud cavities.

UL LISTED PERMABASE® CEMENT BOARD PARTITIONS – WOOD FRAMING

1-hour Fire Rating
U392 UL Design



7/16" PermaBase® PLUS or 1/2" PermaBase applied vertically or horizontally to one side of 2x4 wood studs 16" o.c. with 1-1/4" cement board screws spaced 8" o.c. Ceramic tile installed over PermaBase. 5/8" Fire-Shield Gypsum Board applied vertically or horizontally to opposite side with 6d nails spaced 7" o.c. 3-1/2" mineral wool insulation in stud cavities.

1-hour Fire Rating
U392 UL Design



7/16" PermaBase® PLUS or 1/2" PermaBase applied vertically or horizontally to each side of 2x4 wood studs 16" o.c. with 1-1/4" cement board screws spaced 8" o.c. Ceramic tile installed over PermaBase. 3-1/2" mineral wool insulation in stud cavities.



LIMITED WARRANTY AND REMEDIES

Products manufactured and sold by National Gypsum Company are warranted by National Gypsum Company to its customers to be free from defects in materials and workmanship at the time of shipment. THIS EXPRESS WARRANTY IS THE ONLY WARRANTY APPLICABLE TO SUCH PRODUCTS, AND IS IN LIEU OF AND EXCLUDES ALL OTHER EXPRESS ORAL OR WRITTEN WARRANTIES AND ALL IMPLIED WARRANTIES, INCLUDING BUT NOT LIMITED TO THE IMPLIED WARRANTIES OF MERCHANTABILITY AND FITNESS FOR A PARTICULAR PURPOSE.

National Gypsum Company will not be liable for any incidental, indirect or consequential losses, damages or expenses. The customer's exclusive remedy for any type of claim or action for defective products will be limited to the replacement of the products (in the form originally shipped) or, at National Gypsum's option, to a payment or credit not greater than the original purchase price of the products. National Gypsum Company

Mold And Mildew Resistance

PermaBase® was designed to provide extra protection against mold and mildew. When tested by an independent laboratory, PermaBase received the highest possible ratings on ASTM G21 and D3273. The use of PermaBase in actual installations may not produce the same results as were achieved in controlled laboratory conditions. No material can be considered "mold-proof," nor is it certain that any material will resist

will not be liable for products claimed to be defective where the defect resulted from causes not within National Gypsum's control, or which arose or occurred after shipment, including but not limited to accidents, misuse, mishandling, improper installation, contamination or adulteration by other materials or goods, or abnormal conditions of temperature, moisture, dirt or corrosive matter. Any claim that products sold by National Gypsum Company were defective or otherwise did not conform to the contract of sale is waived unless the customer submits it in writing to National Gypsum within thirty (30) days from the date the customer discovered or should have discovered the defect or nonconformance. No legal action or proceeding complaining of goods sold by National Gypsum may be brought by the customer more than one year after the date the customer discovered or should have discovered the defect or problem of which it complains.

mold or mildew indefinitely. When used in conjunction with good design, handling and construction practices, PermaBase can provide increased mold resistance. As with any building material, avoiding water exposure during handling, storage and installation, and after installation is complete, is the best way to avoid the formation of mold or mildew.

CUSTOMER SERVICE SALES AREAS

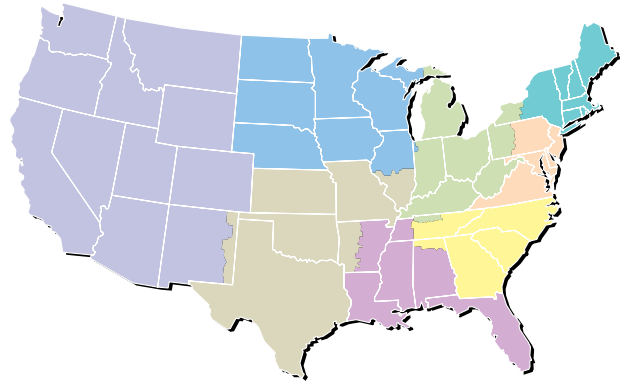

Atlantic Area

Phone: (800) 237-9167
Fax: (877) 252-0430

Central Area

Phone: (800) 252-1065
Fax: (866) 232-0440

Gulf Area

Phone: (800) 343-4893
Fax: (866) 482-8940

Midwest Area

Phone: (800) 323-1447
Fax: (866) 692-8590

Northeast Area

Phone: (800) 253-3161
Fax: (866) 632-1480

Southeast Area

Phone: (800) 548-9394
Fax: (866) 732-1990

Southwest Area

Phone: (800) 548-9396
Fax: (866) 792-7520

Western Area

Phone: (800) 824-4227
Fax: (800) 438-6266

National Accounts

Phone: (800) 440-1230
Fax: (866) 622-3590

Manufactured Housing

Phone: (800) 455-3185
Fax: (800) 639-1714



PRODUCT
CERTIFIED FOR
LOW CHEMICAL
EMISSIONS:
UL.COM/GG
UL 2818

permabase.info

Corporate Headquarters

National Gypsum Properties
2001 Rexford Road
Charlotte, NC 28211
Phone: (704) 365-7300
Web: nationalgypsum.com
Web: permabase.info

Technical Information

Phone: (800) NATIONAL
(800) 628-4662
Fax: (800) FAX-NGC1
(800) 329-6421

