

## Installation

Before applying SOFTR® Duct Wrap FRK, ducts should be clean, dry and tightly sealed at all joints and seams. Install in accordance with instructions so that compression is controlled.

The installed R-value is based on installation of product over sealed sheet metal ductwork with the average installed thickness at 75% of nominal thickness, and thermal conductivity (k) at the installed compressed density. See Thermal Conductivity in the Physical Property Data table located in Product Data Sheet PUB 59241.

Cut SOFTR® Duct Wrap to “stretch-out” dimensions per Table 4. Then cut 2” (50mm) of insulation from the cut end and remove from the facing to form an overlapping staple/ tape flap, see Figure No. 1.

Always install duct wrap with the facing toward the outside. Tightly butt the insulation seams together, see Figure No. 1. The 2” (50mm) formed tape flap must completely overlap the facing and insulation at other end of the piece of duct wrap. Rectangular or square ducts are to be installed so that the insulation is not excessively compressed at duct corners. The side seams shall be stapled approximately 6” (150mm) on center with outward clinching staples, or held in place with three or four evenly spaced 8” long tape tabs.

Adjacent sections of duct wrap shall be tightly butted with the factory 2” (50mm) tape flap edge overlapping the adjoining duct wrap section. In the event that the factory tape flap has been removed, reinstall the 2” (50mm) tape flap as described above.

When a vapor retarder is required, seal all seams and joints with pressure-sensitive tape matching the facing (either plain foil, FRK backing stock, or aluminize mylar), or with glass fabric and mastic. Cloth duct tape of any color and finish using reclaimed rubber adhesives (example: gray duct tape) is not recommended for use on SOFTR® Duct Wrap.

When a vapor retarder is not required, the side seam must be taped as shown in Figure No. 1 to assure the blanket edges are held together to maintain thermal performance and to give a finished appearance.

Where rectangular ducts are 24” (600mm) in width or greater, duct wrap shall be additionally secured to the bottom of the duct with mechanical fasteners such as pins and speed clip washers, spaced on 18” (425mm) centers (maximum) to prevent sagging of insulation.

Figure No. 1

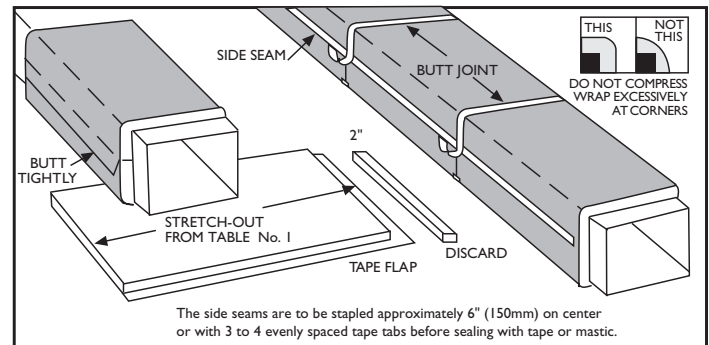

## Material Requirements to Achieve Installed R-Value

Out-Of Package Thickness	Installed Thickness	Stretch-Out Dimensions	
		Round and Oval Ducts	Square and Rectangular Ducts
in.	in.	P+in.	P+in.
1½	1⅛	P+9½	P+8
2	1½	P+12	P+10
2¾/16	1⅝	P+13	P+11
3	2¼	P+17	P+14½

P = measured duct perimeter

When installing SOFTR® Duct Wrap FRK, it is not recommended the use of adhesives to adhere the duct wrap to sheet metal ductwork. When adhesives are used, the insulation is compressed into the adhesive when being installed. The adhesive will not allow the insulation to expand to the desired thickness, therefore affecting the stated R-value and possibly contributing to condensation issues. Additionally, the adhesive could affect the Flame Spread and Smoke Developed Indices of the duct wrap and void all fire ratings.

Where a vapor retarder is required, seal all tears, punctures and other penetrations of the duct wrap facing using one of the above methods to provide a vapor-tight system.



# SOFTR® Duct Wrap Installation Instructions & Manufacturers Fact Sheet

## Manufacturers Fact Sheet

This fact sheet contains important details about Owens Corning® SOFTR® Duct Wrap FRK Insulation. Read it carefully. The chart below covers the entire line of SOFTR® Duct Wrap products sold.

### SOFTR® Duct Wrap FRK Insulation

Product	Out-of-Package Thickness (inches)	Out-of-Package R-Value	Installed Thickness <sup>1</sup> (inches)	Installed (Compressed) R-Value	Width (inches)	Length (feet)	Pieces / Package	Package Sq. Ft.
Type 75 - 0.75 pcf density								
Type 75	1.5	5.1	1.125	4.2	48	100	1	400
Type 75	2.0	6.8	1.5	5.6	48	75	1	300
Type 75	2.2	7.4	1.625	6.0	48	75	1	300
Type 75	3.0	10.0	2.25	8.3	48	50	1	200
Type 100 - 1.00 pcf density								
Type 100	1.5	5.6	1.125	4.5	48	100	1	400
Type 100	2.0	7.4	1.5	6.0	48	75	1	300
Type 150 - 1.50 pcf density								
Type 150	1.5	6.0	1.125	4.8	48	75	1	300
Type 150	2.0	8.0	1.5	6.4	48	50	1	200

<sup>1</sup> The R-value of this insulation varies depending on how much it is compressed during installation. Assumes that Duct Wrap is installed at 75% of out-of-package thickness for Installed (Compressed) R-Value.

### Read This Before You Buy

#### What you should know about R-Values

The chart shows the R-values of this insulation. R means resistance to heat flow. The higher the R-value, the greater the insulating power. Compare insulation R-values before you buy. There are other factors to consider. The amount of insulation you need depends mainly on the climate you live in. Also, your fuel savings from insulation will depend on the climate, the type and size of house, the amount of insulation already in your house, and your fuel-use patterns and family size. If you buy too much insulation, it will cost you more than what you'll save on fuel. To get the marked R-value, it is essential that this insulation be installed properly.

Please contact 419-248-6557 for additional information. Email: [gettech@owenscorning.com](mailto:gettech@owenscorning.com)