

UL Evaluation Report

UL ER2453-01

Issued: August 2, 2013

Revised: April 5, 2017

Visit UL's On-Line Certifications Directory: www.ul.com/erdirectory
for current status of Report.

UL Category Code: ULEZ

CSI MasterFormat®

DIVISION: 07 00 00 – THERMAL AND MOISTURE PROTECTION

Sub-level 2: 07 30 00 – Steep Slope Roofing

Sub-level 3: 07 31 00 – Shingles and Shakes

Sub-level 4: 07 31 13 – Asphalt Shingles

COMPANY:

OWENS CORNING

ONE OWENS CORNING PKY

TOLEDO, OH 43659

(419) 248-7060

<http://www.owenscorning.com/>

1. SUBJECT: Asphalt Shingles

CLASSIC®, SUPREME®,

DURATION® PREMIUM, TRUDEFINITION® DURATION®, TRUDEFINITION® DURATION® STORM™, TRUDEFINITION® DURATION® MAX™, TRUDEFINITION® OAKRIDGE®, OAKRIDGE®, WOODCREST®, WOODMOOR®, TRUDEFINITION® WEATHERGUARD® HP, BERKSHIRE®, DEVONSHIRE™,

WOODSTART® STARTER SHINGLE, STARTER STRIP PLUS, STARTER STRIP SHINGLE, AND TRI BUILT STARTER STRIP

BERKSHIRE® HIP & RIDGE SHINGLES, HIGH RIDGE HIP & RIDGE SHINGLES WITH SEALANT, RIZERIDGE® HIP & RIDGE SHINGLES WITH SEALANT, WEATHERGUARD® HP HIP & RIDGE SHINGLES, PROEDGE®, DURARIDGE™ HIP & RIDGE SHINGLES AND PROEDGE® STORM® HIP & RIDGE SHINGLES

2. SCOPE OF EVALUATION

- 2015, 2012, 2009, and 2006 *International Building Code*® (IBC)
- 2015, 2012, 2009, and 2006 *International Residential Code*® (IRC)
- ICC ES Acceptance Criteria for Quality Documentation (AC10), Dated December 2012
- ICC ES Acceptance Criteria for Alternative Asphalt Roofing Shingles (AC438), Dated March 2012



The products were evaluated for the following properties:

- External Fire Exposure (ANSI/UL790, ASTM E108)
- Wind Resistance (ASTM D3161; ASTM D7158)
- Physical Properties (ASTM D3462, ICC-ES AC438)

3. REFERENCED DOCUMENTS

- ANSI/UL790 Eighth Edition, (ASTM E108), Standard Test Methods for Fire Tests of Roof Coverings
- ASTM D3161-13, Standard Test Method for Wind-Resistance of Steep Slope Roofing Products (Fan-Induced Method)
- ASTM D7158-11, Standard Test Method for Wind Resistance of Asphalt Shingles (Uplift Force/Uplift Resistance Method)
- ASTM D3462-10A, Standard Specification for Asphalt Shingles Made from Glass Felt and Surfaced with Mineral Granules
- UL Subject 2375, Outline of Investigation for Hip and Ridge Shingles (UL Fire and Wind Tests)
- ICC-ES Acceptance Criteria for Alternative Asphalt Roofing Shingles (AC438), Dated March 2012

4. USES

OWENS CORNING asphalt shingles are used as roof coverings for new and existing roofs.

5. PRODUCT DESCRIPTION

OWENS CORNING asphalt shingles are roof covering materials complying with the following properties when installed as described in this report. The products are three-tab shingles, laminated shingles and hip & ridge shingles. The products are available in standard and metric sizes.

Fire Classification: OWENS CORNING asphalt shingles covered under this Report have been tested for fire classification Class A in accordance with UL790 (ASTM E108). Shingles tested in accordance with UL790 (ASTM E108) qualify for use under Section 1505.1 of the 2012, 2009 and 2006 IBC and Section R902.1 of the 2012, 2009 and 2006 IRC.

Wind Resistance: OWENS CORNING asphalt shingles covered under this Report have been tested for wind resistance in accordance with ASTM D3161 or ASTM D7158.

Shingles tested in accordance with ASTM D3161 are classified as Class F or Class A and qualify for use under the exception to Section 1507.2.8.1 of the 2015 IBC, Section 1507.2.7.1 of the 2012, 2009 and 2006 IBC, or the exception to Section R905.2.4.1 of the 2015, 2012, 2009 and 2006 IRC.

Shingles tested in accordance with ASTM D7158 are classified as Class H and qualify for use in locations as shown in Table 1504.1.1 of the 2015 IBC, Table 1507.2.7.1 of the 2012 and 2009 IBC or Table R905.2.4.1 of the 2015, 2012 and 2009 IRC, where the maximum basic wind speed is 150 mph (67 m/s) or less with exposure category of B or C (ASCE 7) and a maximum building height of 60 feet (18.3 m). Installation must be in accordance with Section 1507.2.7 of the 2015, 2012, 2009 and 2006 IBC or Section R905.2.6 of the 2015, 2012, 2009 and 2006 IRC, as applicable.

Physical Properties: OWENS CORNING asphalt shingles covered under this Report have been tested for physical properties in accordance with ASTM D3462. Shingles tested in accordance with ASTM D3462 qualify for use under Section 1507.2.5 of the 2015, 2012, 2009 and 2006 IBC or Section R905.2.4 of the 2015, 2012, 2009 and 2006 IRC. Shingles have also been evaluated in accordance with ICC-ES Acceptance Criteria, AC438. When installed on new construction in accordance with this report and the OWENS CORNING installation instructions, the shingles are a Class A fire classification roof covering. When the shingles are installed over existing roof coverings, the fire classification is maintained.

5.1 Three-Tab Shingles – Classic® , and Supreme® :

Classic® and Supreme® shingles are three-tab shingles manufactured with a single fiberglass mat, coated on both sides with asphalt, and surfaced on the weather-exposed side with mineral granules. The shingles are self-sealing and have a continuous bead of thermal-tab sealing adhesive above the shingle butt on the weather side. The shingles are self-sealing and have a dashed bead of thermal-tab sealing adhesive above the shingle butt on the weather side. See Tables 2 and 3 respectively for product dimensions and manufacturing locations.

5.2 Five-Tab Shingles - Devonshire™

Devonshire™ shingles are five-tab shingles manufactured with a single fiberglass mat, coated on both sides with asphalt, and surfaced on the weather-exposed side with mineral granules. The shingles are self-sealing and have a dashed bead of thermal-tab sealing adhesive above the shingle butt on the weather side. See Table 13A for product dimensions and manufacturing locations.

5.3 Laminated Shingles – Duration® Premium, TruDefinition® Duration®, TruDefinition® Duration® Storm, TruDefinition® Duration® MAX, TruDefinition® Oakridge®, Oakridge®, Woodcrest®, Woodmoor®, TruDefinition® WeatherGuard® HP, Berkshire®:

Duration® Premium, TruDefinition® Duration®, TruDefinition® Duration® Storm, TruDefinition® Duration® MAX, Oakridge®, Woodcrest®, Woodmoor®, TruDefinition® WeatherGuard® HP, Berkshire® shingles are laminated shingles manufactured with 2 layers of fiberglass mat coated with asphalt on both sides, and surfaced on the weather-exposed side with mineral granules.

5.4 Hip & Ridge Shingles – Berkshire® Hip & Ridge Shingles, High Ridge Hip & Ridge with Sealant, ProEdge®, ProEdge® Storm®, WeatherGuard® HP, DuraRidge™ Hip and Ridge Shingles, and RIZERidge® Hip and Ridge shingles with Sealant:

Berkshire® Hip & Ridge Shingles, High Ridge Hip and Ridge Shingles with Sealant, ProEdge®, ProEdge Storm™, WeatherGuard® HP, DuraRidge™ Hip and Ridge Shingles and RIZERidge® Hip and Ridge shingles with Sealant are prefabricated hip and ridge shingles. ProEdge Storm™ and WeatherGuard® HP hip and ridge shingles are perforated so they can be torn into three 12 inch by 12 inch (305 mm by 305 mm) shingles. ProEdge® hip and ridge shingles and RIZERidge® Hip and Ridge shingles with Sealant are perforated so they can be torn into three 12 inch by 12 inch (305 mm by 305 mm) shingles for standard , or four 13-¹/₄ inch by 9-²⁷/₃₂ inch (337 mm by 250 mm) shingles for metric.

5.5 Starter Shingles - Starter Strip, Starter Strip Plus, Woodstart Starter Shingle, and Tri-Built Starter Strip

Starter Strip, Starter Strip Plus, Woodstart Starter Shingle, and Tri-Built Starter Strip are prefabricated starter course shingles with factory applied sealant. Starter Strip and Tri-Built Starter Strip are 6-5/8" x 39-3/8". Starter Strip Plus and Tri-Built Starter Strip are 7-3/4" x 13-3/8". Woodstart Starter Shingles are 13-3/8" x 40".

6. INSTALLATION

OWENS CORNING asphalt shingles must be installed in accordance with the applicable code, this report, and the manufacturer's published installation instructions. The shingles must be installed in accordance with Section 1507.2 of the 2012, 2009 and 2006 IBC or Section R905.2 of the 2015, 2012, 2009 and 2006 IRC, as applicable, except as noted in this report.

The manufacturer's published installation instructions must be available at all times on the jobsite during installation.

Minimum roof slopes must be 2:12 (16.67% slope or 9°) for the three-tab shingles described in section 5.1 and for the laminated shingles described in section 5.3 of this Report.

6.1 Underlayment and Ice Barriers:

For roof slopes greater than 4:12 (33.33% slope or 18°), the roof deck must be covered with a minimum of one layer of underlayment as described in Sections 7.2 and 7.3 of this Report. Underlayment application must be in accordance with Section 1507.2.8 of the 2015, 2012, 2009 and 2006 IBC, Section R905.2.7 of the 2015, 2012, 2009 and 2006 IRC, as applicable.

Roofs having slopes between 2:12 (16.67% slope or 9°) and 4:12 (33.33% slope or 18°) require two layers of the underlayment as described in Sections 7.2 and 7.3 of this Report. Underlayment application must be in accordance with Section 1507.2.8 of the 2015, 2012, 2009 and 2006 IBC or Section R905.2.3 of the 2015 IRC, or Section R905.2.7 of the 2012, 2009 and 2006 of the IRC, as applicable.

In areas where there has been a history of ice forming along the eaves, causing a backup of water, as indicated by Table R301.2 (1), an ice barrier must be provided in accordance with Section 1507.2.8.2 of the 2015, 2012, 2009 and 2006 IBC or Section R905.2.7 of the 2015 IRC or Section R905.2.7.1 of the 2012, 2009 and 2006 IRC, as applicable.

6.2 Starter Shingle:

A starter course, as described in Section 7.4 of this Report, must be attached to the eave edge using fasteners described in Section 7.5 of this Report, located 1-½ – 3 inches (38 – 76 mm) from the eave edge and spaced 8 – 10 inch (203 – 254 mm) apart, for a total of five fasteners per shingle. The starter strip must overhang the eaves and rake edges by ¼ – ¾ inch (6 – 19 mm). See Tables 16-17.

6.3 Asphalt Shingles:

The first course of field shingles must be installed over the starter course described in Section 7.4 of this Report.

Standard three-tab shingles must be installed with vertical joints offset 4 inches (102 mm), 5 inches (127 mm), or 6 inches (152 mm) from adjacent courses and metric-sized three-tab shingles must be installed with a 6-9/16 inch (167 mm) offset or any repeatable offset pattern greater than 4 inches (102 mm).

Duration® Premium, TruDefinition® Duration®, TruDefinition® Duration® Storm™, TruDefinition® Duration® MAX, TruDefinition® Oakridge®, Oakridge®, and TruDefinition® WeatherGuard® HP must be installed with a 6-½ inch (165 mm) offset or any repeatable offset pattern greater than 4 inches (102 mm).

The Berkshire® shingles must be installed with a 4-¾ inch (121 mm) offset.

Woodcrest® and Woodmoor® must be installed with a 5 and 5 inch (127 and 127 mm) or a 5 inch and 15 inch (127 and 381 mm) offset.

End joints must be a minimum of 2 inches (51 mm) from a fastener in the shingle below. Offset patterns between courses may vary provided side laps are a minimum of 4 inches (102 mm) in succeeding courses.

6.3.1 Three-Tab Shingles – Classic®, and Supreme®:

For roof slopes of 2:12 up to 21:12 (16.67% or 9° up to 175% or 60°), each shingle must be fastened to the roof deck using a minimum of four fasteners, spaced as shown in Tables 2 and 3.

For roof slopes over 21:12 (175% or 60°), six fasteners must be used, spaced as shown in Tables and four 1 inch diameter spots of asphalt plastic cement per shingle (2 inches up from the bottom edge), spaced as shown in Tables 2 and 3.

Fasteners must be located above the top of the cut-out and below the sealant strip, $\frac{5}{8}$ inch (16 mm) above the tab cut-out.

Maximum exposure to the weather must be 5 inches or $5\frac{5}{8} \pm \frac{1}{8}$ inches (127 or 143 ± 3 mm). In colder climates or wind regions where it is questionable whether the thermal-sealing adhesive will activate to seal the shingles, the shingles can be hand-sealed. A 1-in diameter (25.4 mm) spot of asphalt cement complying with ASTM D4586, Type I, Class I, should be placed under the corner (1 – 2 inches (25 – 51 mm) from each end) of each tab (two spots per tab).

6.3.2 Five-Tab Shingles – Devonshire™:

For roof slopes of 2:12 up to 21:12 (16.67% or 9° up to 175% or 60°) each shingle must be fastened to the roof deck using a minimum of six fasteners, spaced as shown in Table 13A.

For roof slopes over 21:12 (175% or 60°), six fasteners must be used, and ten 1 inch diameter spots of asphalt plastic cement per shingle and two spots of asphalt plastic cement under each shingle tab spaced as shown in Table 13A.

Fasteners must be located $6\frac{1}{8}$ inches (157 mm) above the butt edge of the shingles.

Maximum exposure to the weather must be $5\frac{5}{8} \pm \frac{1}{8}$ inches (143 ± 3 mm).

In colder climates or wind regions where it is questionable whether the thermal-sealing adhesive will activate to seal the shingles, the shingles can be hand-sealed. Two, 1-inch diameter (25.4 mm) spots of cement should be placed under each shingle (Ten per shingle), spaced as shown in Tables 13A.

6.3.3 Laminated Shingles – Duration® Premium, TruDefinition® Duration®, TruDefinition® Duration® Storm, TruDefinition® Duration® MAX:

For roof slopes of 2:12 up to 21:12 (16.67% or 9° up to 175% or 60°), each shingle must be fastened to the roof deck using a minimum of four fasteners, spaced as shown in Tables 4-7.

For roof slopes over 21:12 (175% or 60°), six fasteners must be used, spaced as shown in Tables 4-7.

Fasteners must be located $6\frac{1}{8}$ inches (157 mm) above the butt edge of the shingles (center of the SureNail® fastening area).

Maximum exposure to the weather must be $5\frac{5}{8} \pm \frac{1}{8}$ inch (143 ± 3 mm)

In colder climates or wind regions where it is questionable whether the thermal-sealing adhesive will activate to seal the shingles, the shingles can be hand-sealed. Four, 1-inch diameter (25.4 mm) spots of cement should be placed under the exposed portion of the

shingle, spaced 1 – 2 inches (25 – 51 mm) from each end of the shingle and two spots must be evenly spaced in between.

6.3.4 Laminated Shingles – Oakridge® and TruDefinition® Oakridge®:

For roof slopes of 2:12 up to 21:12 (16.67% or 9° up to 175% or 60°), each shingle must be fastened to the roof deck using a minimum of four fasteners, spaced as shown in Tables 8-9.

For roof slopes over 21:12 (175% or 60°), six fasteners must be used, and four 1 inch diameter spots of asphalt plastic cement per shingle (2 inches up from the bottom edge), spaced as shown in Tables 8-9.

Fasteners must be located 6-¹/₈ inches (157 mm) above the butt edge of the shingles.

Maximum exposure to the weather must be 5-⁵/₈ ± ¹/₈ inches (143 ± 3 mm)

In colder climates or wind regions where it is questionable whether the thermal-sealing adhesive will activate to seal the shingles, the shingles can be hand-sealed. Four, 1-inch diameter (25.4 mm) spots of cement should be placed under the exposed portion of the shingle, spaced 1 – 2 inches (25 – 51 mm) from each end of the shingle and two spots must be evenly spaced in between.

6.3.5 Laminated Shingles – Berkshire®:

For roof slopes of 2:12 up to 21:12 (16.67% or 9° up to 175% or 60°), each shingle must be fastened to the roof deck using a minimum of five fasteners, spaced as shown in Table 10.

For roof slopes over 21:12 (175% or 60°), six fasteners must be used and four 1 inch diameter spots of asphalt plastic cement per shingle and one spot of asphalt under each shingle tab, center of the shingle tab and 2 inches up from the bottom edge, spaced as shown in Table 10.

Fasteners must be located above the top of the cut-out and below the sealant strip, ⁵/₈ inch (16 mm) above the tab cut-out.

Maximum exposure to the weather must be 8-³/₈ ± ¹/₈ inch (213 ± 3 mm).

In colder climates or wind regions where it is questionable whether the thermal-sealing adhesive will activate to seal the shingles, the shingles can be hand-sealed. A 1-inch diameter (25.4 mm) spot of asphalt cement complying with ASTM D4586, Type I, Class I, should be placed under the corner 1 – 2 inches (25 – 51 mm) from each end of each tab (two spots per tab).

6.3.6 Laminated Shingles – Woodcrest® and Woodmoor®:

For roof slopes of 2:12 up to 21:12 (16.67% or 9° up to 175% or 60°), each shingle must be fastened to the roof deck using a minimum of five fasteners, spaced as shown in Tables 11 and 12 .

For roof slopes over 21:12 (175% or 60°), nine fasteners must be used, and four, 1 inch diameter spots of asphalt plastic cement per shingle and one spot of asphalt under each shingle tab, center of the shingle tab and 2 inches up from the bottom edge, spaced as shown in Tables 11-12.

Fasteners must be located in the center of the SureNail® fastening area as shown in Tables 11-12.

Maximum exposure to the weather must be 4 ± ¹/₈ inches (102 ± 3 mm).

In colder climates or wind regions where it is questionable whether the thermal-sealing adhesive will activate to seal the shingles, the shingles can be hand-sealed. A 1-inch diameter (25.4 mm) spot of asphalt cement complying with ASTM D4586, Type I, Class I, should be placed under the corner 1 – 2 inches (25 – 51 mm) from each end of each tab (two spots per tab).

6.3.7 Laminated Shingles – TruDefinition® WeatherGuard® HP:

For roof slopes of 2:12 up to 21:12 (16.67% or 9° up to 175% or 60°), each shingle must be fastened to the roof deck using a minimum of six fasteners, spaced as shown in Table 13.

For roof slopes over 21:12 (175% or 60°), six fasteners must be used, spaced as shown in Table 13.

Fasteners must be located 6-¹/₈ inches (157 mm) above the butt edge of the shingles.

Maximum exposure to the weather must be 5-⁵/₈ ± ¹/₈ inch (143 ± 3 mm).

In colder climates or wind regions where it is questionable whether the thermal-sealing adhesive will activate to seal the shingles, the shingles can be hand-sealed. Four, 1-inch diameter (25.4 mm) spots of cement should be placed under the exposed portion of the shingle, spaced 1 – 2 inches (25 – 51 mm) from each end of the shingle and two spots must be evenly spaced in between.

6.4 Valley Construction and Other Flashing:

Valleys must consist of woven, open valley or closed-cut construction and must be flashed in accordance with Section 1507.2.9.2 of the 2015, 2012, 2009 and 2006 IBC or Section R905.2.8.2 of the 2015, 2012, 2009 and 2006 IRC. Other flashings must be in accordance with Sections 1503.2 and 1507.2.9 of the 2015, 2012, 2009 and 2006 IBC, or Sections R903.2 and 905.2.8 of the 2015 2012, 2009 and 2006 IRC, as applicable.

6.5 Hip and Ridge Application:

Hip and ridge shingles must be placed evenly over hips and ridges, and must be fastened to the roof deck using minimum two fasteners, one located on either side of the shingle, 1 inch (25.4 mm) up from the edge. Berkshire® Hip & Ridge Shingles, DuraRidge® Hip and Ridge Shingles and High Ridge Hip & Ridge with Sealant prefabricated hip and ridge shingles must be installed with a maximum exposure of 8 inches (203 mm). WeatherGuard® HP, ProEdge®, ProEdge Storm®, and RIZERidge® prefabricated hip ridge shingles must be installed with a maximum exposure of 6 inches (127 mm). Nailing for Hip and Ridge shingles are shown in Tables 14, 14A, 14B, 14C, and 14D.

6.6 Reroofing:

The existing asphalt shingle roof covering must be inspected in accordance with the provisions and limitations of Section 1511 of the 2015 IBC, Section 1510 of the 2012, 2009 and 2006 IBC or Section R908 of the 2015 IRC or Section R907 of the 2012, 2009 and 2006 IRC, as applicable. Prior to the reroofing, hip and ridge coverings must be removed.

Except as noted in this section, the shingles must be installed in accordance with Section 6.3 and 6.5 of this Report. Fasteners must be of sufficient length to penetrate ³/₄ inch (19.1 mm) into the sheathing, or through the sheathing where the sheathing is less than ³/₄ inch (19.1 mm) thick. Flashing and edging must comply with Section 6.4 and with Sections 1511.5 and 1511.6 of the 2015 IBC, Sections 1510.5 and 1510.6 of the 2012, 2009 and 2006 IBC and Sections R908.5 and R908.6 of the 2015 IRC, and Sections R907.5 and R907.6 of the 2012, 2009 and 2006 IRC, as applicable.

7. INSTALLATION MATERIALS

7.1 Sheathing:

The roof deck must be code-complying, minimum 3/8-inch thick (9.5 mm), exterior plywood complying with DOC PS-1; rated sheathing complying with DOC PS-2; or solid sheathing using minimum nominally 1 by 6 lumber.

7.2 Underlayment:

Under the IBC or IRC, underlayment must comply with ASTM D226, Type I, ASTM D4869, Type I or ASTM D6757 as specified in Section 1507.2.3 of the 2015, 2012, 2009 and 2006 IBC or IRC Section R905.2.3 of the 2015, 2012, 2009 and 2006 IRC

7.3 Self-adhering Polymer Modified Bitumen Sheet:

When used as an underlayment under shingles described herein, self-adhering polymer modified bitumen sheet must comply with ASTM D1970.

7.4 Starter Shingles:

The starter course shingle may consist of Woodstart ® Starter Shingle, Starter Strip Plus, Starter Strip Shingle, or Tri Built Starter Strip. If self-sealing three-tab shingles are used, remove the exposed tab portion and install with factory-applied sealant adjacent to the eaves.

7.5 Fasteners:

Fasteners must be minimum No. 12 gage [0.105 inch (2.7 mm)], 3/8-inch diameter head (9.5 mm), galvanized, stainless steel, aluminum or copper corrosion-resistance nails. Fasteners must be of sufficient length to penetrate into the sheathing min. 3/4-inch (19.1 mm), or through the sheathing, where the sheathing is less than 3/4-inch (19.1 mm) thick. Fasteners must comply with ASTM F1667.

7.6 Asphalt Cement:

Asphalt cement must comply with ASTM D4586, Type I, Class I.

8. CONDITIONS OF USE

The OWENS CORNING Asphalt Shingles described in this Report comply with, or are suitable alternatives to, what is specified in those codes listed in Section 2 of this Report, subject to the following conditions:

- 8.1 Materials and methods of installation shall comply with this Report and the manufacturer's published installation instructions. In the event of a conflict between the installation instructions and this Report, this Report governs.
- 8.2 The products are manufactured at the locations listed in Table 1 of this Report under the UL LLC Classification and Follow-Up Service Program, which includes audits in accordance with quality elements of ICC-ES Acceptance Criteria for Quality Documentation, AC10.
- 8.3 See UL Online Certifications Directory for Prepared Roof-Covering Materials (TFWZ and TGAH).

9. SUPPORTING EVIDENCE

- 9.1 Manufacturer's descriptive product literature, including installation instructions.

- 9.2 UL test reports and Classification in accordance with ANSI/UL 790, Class A and UL Subject 2375. See UL Product Certification Category for Prepared Roof-Covering Materials (TFWZ).
- 9.3 UL test reports and Classification in accordance with ASTM D3462. See UL Product Certification Category for Prepared Roof-Covering Materials (TFWZ).
- 9.4 UL Test reports and Classification in accordance with ICC-ES Acceptance Criteria for Alternative Asphalt Roofing Shingles, AC438
- 9.5 UL test reports and Classification in accordance with UL 2390/ASTM D7158, Class H. See UL Product Certification Category for Prepared Roof-Covering Materials (TGAH).
- 9.6 UL test reports and Classification in accordance with ASTM D3161, Class F. See UL Product Certification Category for Prepared Roof-Covering Materials (TFWZ).
- 9.7 Quality Documentation in accordance with ICC-ES Acceptance Criteria for Quality Documentation, AC10.

See UL's On-Line Certification Directory for the following product categories referenced above:

- [TFWZ](#)
- [TGAH](#)

10. IDENTIFICATION

OWENS CORNING asphalt shingles described in this Evaluation Report are identified by a marking bearing the report holder's name (OWENS CORNING), the plant identification, the product name, the UL Classification Mark and the evaluation report number ULER2453-01. The validity of this Evaluation Report is contingent upon this identification appearing on the product. . The UL Classification Mark shall indicate:

- a. UL790/ASTM E108 - Class A
- b. ASTM D3161 – Class F or Class A
- c. UL2390 (ASTM D7158) – Class H
- d. ASTM D3462
- e. ICC-ES Acceptance Criteria, AC438

11. USE OF UL EVALUATION REPORT

- 11.1 The approval of building products, materials or systems is under the responsibility of the applicable authorities having jurisdiction.
- 11.2 UL Evaluation Reports shall not be used in any manner that implies an endorsement of the product, material or system by UL.
- 11.3 The current status of this report, as well as a complete directory of UL Evaluation Reports may be found at UL.com via our On-Line Certifications Directory: www.ul.com/erdirectory

Table 1 – Manufacturing Locations

LISTEE	LOCATION	FACTORY ID
OWENS CORNING	5201 FOX ST DENVER CO 80216	DENVER
OWENS CORNING	704 CORRINE AVE N STATION MEMPHIS TN 38107	MEMPHIS
OWENS CORNING	1249 NEWARK TPKE KEARNY NJ 07032	KEARNY
OWENS CORNING	1901 49TH AVE N MINNEAPOLIS MN 55430	MINNEAPOLIS
OWENS CORNING	128 W 8TH ST BROOKVILLE IN 47012	BROOKVILLE
OWENS CORNING	1501 N TAMARIND ST PO BOX 5665 COMPTON CA 90224	COMPTON
OWENS CORNING	8360 MARKET ST RD HOUSTON TX 77029	HOUSTON
OWENS CORNING	201 N NURSERY RD IRVING TX 75061	IRVING
OWENS CORNING	3750 NW YEON AVE PORTLAND OR 97208	PORTLAND
OWENS CORNING	5824 S ARCHER RD SUMMIT IL 60501	SUMMIT
OWENS CORNING	4795 FREDERICK DR ATLANTA GA 30336	ATLANTA
OWENS CORNING	1035 TALLEYRAND AVE JACKSONVILLE FL 32206	JACKSONVILLE
OWENS CORNING	890 W SMITH RD MEDINA OH 44256	MEDINA
OWENS CORNING	1 FOUNDATION DR SAVANNAH GA 31408	SAVANNAH

Table 2 – Classic®

<p>Plant Location(s):</p>	<p>Medina, OH; Summit, IL</p>
<p>Dimensions:</p>	<p>12" x 36"</p>
<p>Fastening Pattern:</p>	<p>For slopes of 2:12 up to 21:12</p>  <p>5" Exposure</p>
<p>Fastening Pattern:</p>	<p>For slopes greater than 21:12</p> 

Table 3 – Supreme®

<p>Plant Location(s):</p>	<p>Atlanta, GA; Denver, CO; Irving, TX; Medina, OH; Memphis, TN; Portland, OR; Summit, IL</p>
<p>Dimensions:</p>	<p>12" x 36"</p>
<p>Fastening Pattern:</p>	<p>For slopes of 2:12 up to 21:12</p>  <p>5" Exposure</p>
<p>Fastening Pattern:</p>	<p>For slopes greater than 21:12</p> 
<p>Plant Location(s):</p>	<p>Compton, CA; Kearny, NJ; Portland, OR</p>
<p>Dimensions:</p>	<p>13-1/4" x 39-3/8"</p>
<p>Fastening Pattern:</p>	<p>For slopes of 2:12 up to 21:12</p>  <p>5 5/8" Exposure</p>
<p>Fastening Pattern:</p>	<p>For slopes greater than 21:12</p> 

Table 4 – Duration® Premium

<p>Plant Location(s):</p>	<p>Compton, CA; Portland, OR</p>
<p>Dimensions:</p>	<p>39-3/8" x 13-1/4"</p>
<p>Fastening Pattern:</p>	<p>For slopes of 2:12 up to 21:12</p> 
<p>Fastening Pattern:</p>	<p>For slopes greater than 21:12</p> 

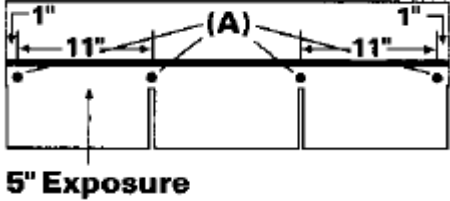
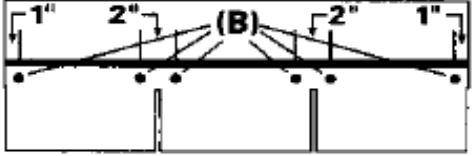
Table 5 – TruDefinition® Duration®

<p>Plant Location(s):</p>	<p>Brookville, IN; Compton CA; Denver, CO; Irving, TX; Jacksonville, FL; Kearny, NJ; Medina, OH; Minneapolis, MN; Portland, OR; Savannah, GA</p>
<p>Dimensions:</p>	<p>39-3/8" x 13-1/4"</p>
<p>Fastening Pattern:</p>	<p>For slopes of 2:12 up to 21:12</p> 
<p>Fastening Pattern:</p>	<p>For slopes greater than 21:12</p> 

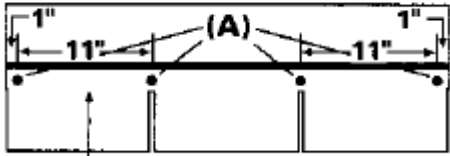
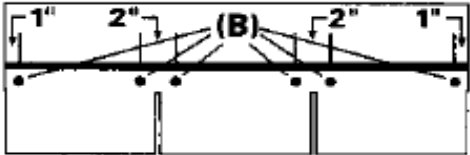
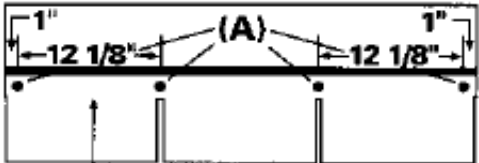
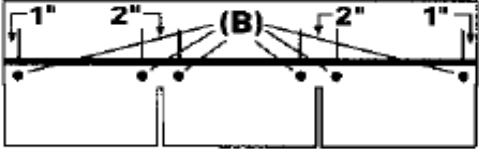
Table 6 – TruDefinition® Duration® Storm®

<p>Plant Location(s):</p>	<p>Denver, CO</p>
<p>Dimensions:</p>	<p>39-3/8" x 13-1/4"</p>
<p>Fastening Pattern:</p>	<p>For slopes of 2:12 up to 21:12</p> 
<p>Fastening Pattern:</p>	<p>For slopes greater than 21:12</p> 

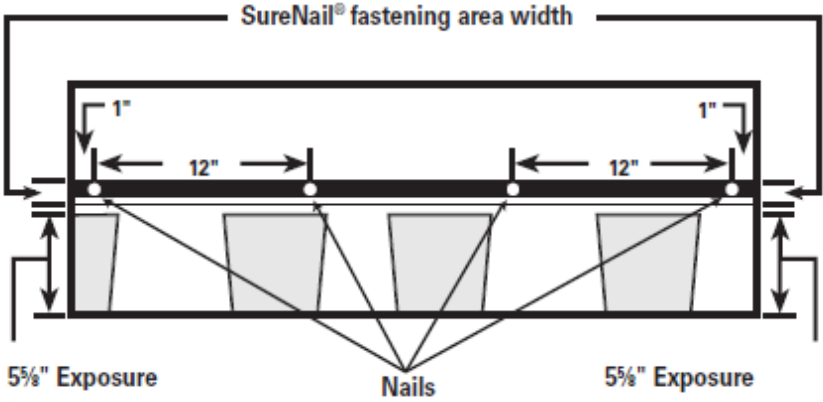
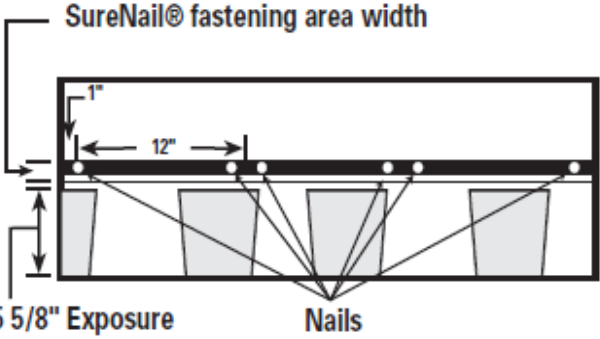
Table 7 – TruDefinition® Duration® MAX

<p>Plant Location(s):</p>	<p>Compton, CA</p>
<p>Dimensions:</p>	<p>39-3/8" x 13-1/4"</p>
<p>Fastening Pattern:</p>	<p>For slopes of 2:12 up to 21:12</p> 
<p>Fastening Pattern:</p>	<p>For slopes greater than 21:12</p> 

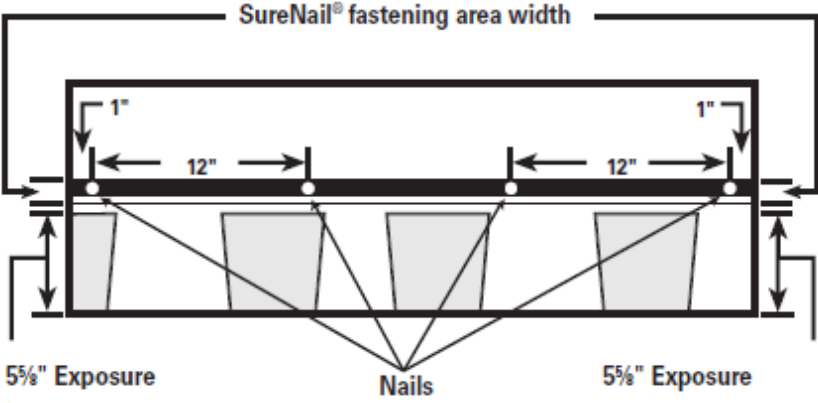
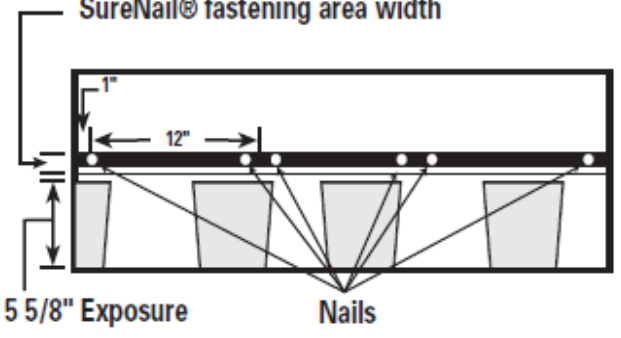
Table 8 – Oakridge®

<p>Plant Location(s):</p>	<p>Atlanta, GA; Brookville, IN; Compton, CA; Denver, CO; Houston, TX; Irving, TX; Jacksonville, FL; Kearny, NJ; Medina, OH; Memphis, TN</p>
<p>Dimensions:</p>	<p>39-3/8" x 13-1/4"</p>
<p>Fastening Pattern:</p>	<p>For slopes of 2:12 up to 21:12</p>  <p>5 5/8" Exposure</p> <p>Nails</p> <p>5 5/8" Exposure</p>
<p>Fastening Pattern:</p>	<p>For slopes greater than 21:12</p>  <p>5 5/8" Exposure</p> <p>6 Fasteners</p> <p>5 5/8" Exposure</p> <p>Four 1" Spots of Asphalt Cement</p>

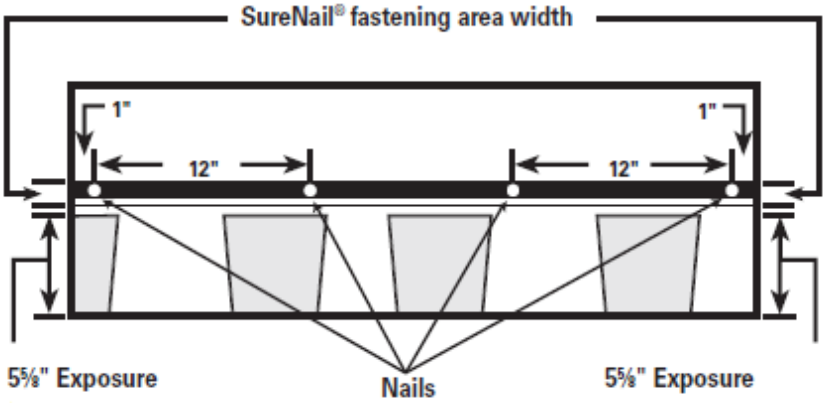
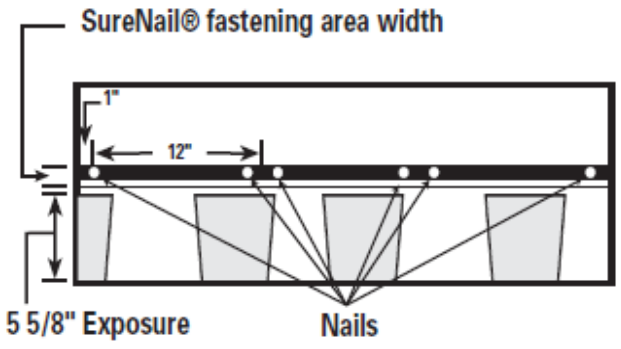
Table 9 – TruDefinition® Oakridge®

<p>Plant Location(s):</p>	<p>Houston, TX : Irving, TX</p>
<p>Dimensions:</p>	<p>39-3/8" x 13-1/4"</p>
<p>Fastening Pattern:</p>	<p>For slopes of 2:12 up to 21:12</p> 
<p>Fastening Pattern:</p>	<p>For slopes greater than 21:12</p> 

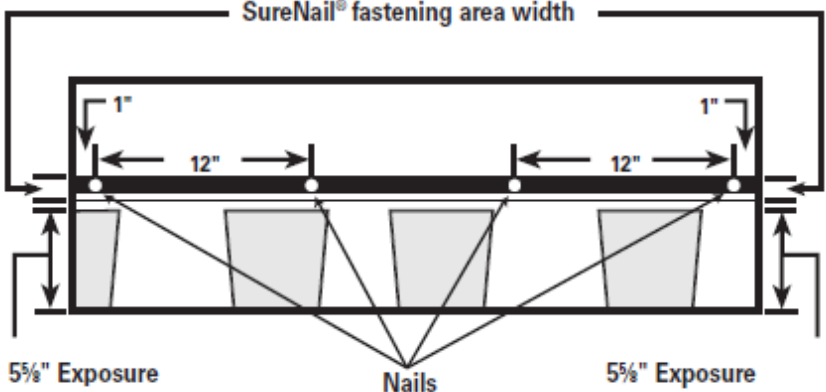
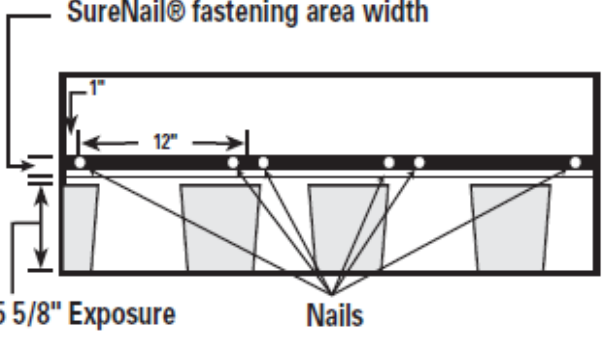
Table 10 – Berkshire®

<p>Plant Location(s):</p>	<p>Minneapolis, MN</p>
<p>Dimensions:</p>	<p>38"x18-3/4"</p>
<p>Fastening Pattern:</p>	<p>For slopes of 2:12 up to 21:12</p> 
<p>Fastening Pattern:</p>	<p>For slopes greater than 21:12</p> 

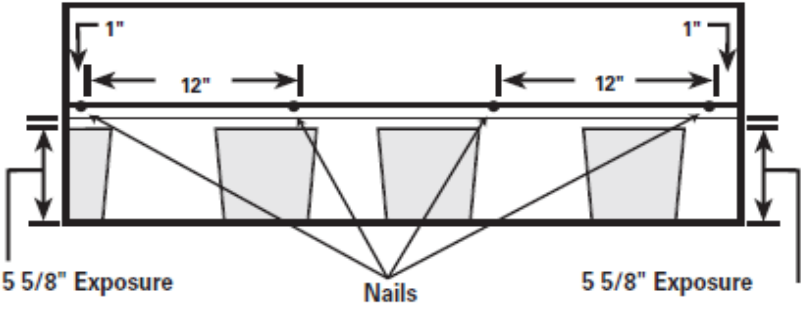
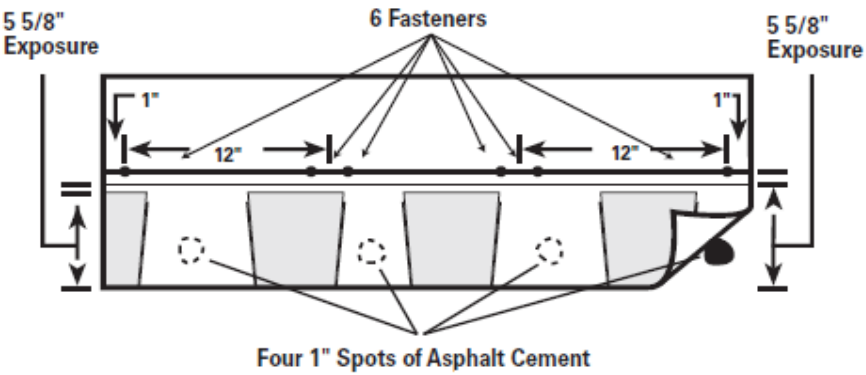
Table 11 – Woodcrest®

<p>Plant Location(s):</p>	<p>Compton, CA</p>
<p>Dimensions:</p>	<p>40" x 14-1/4"</p>
<p>Fastening Pattern:</p>	<p>For slopes of 2:12 up to 21:12</p> 
<p>Fastening Pattern:</p>	<p>For slopes greater than 21:12</p> 

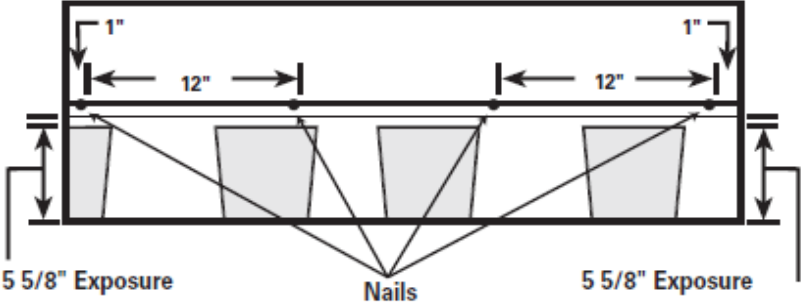
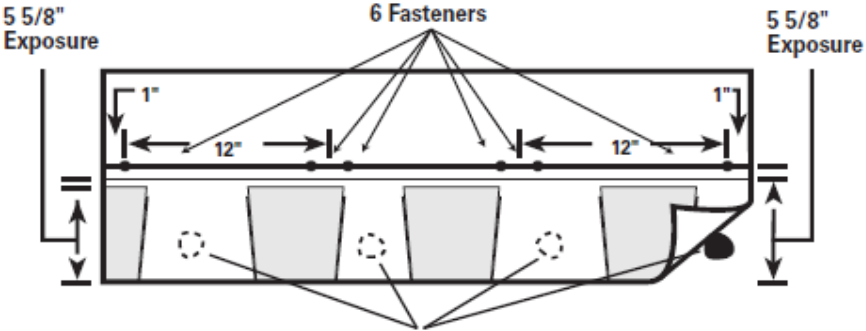
Table 12 – Woodmoor®

<p>Plant Location(s):</p>	<p>Compton, CA</p>
<p>Dimensions:</p>	<p>40" x 14-1/4"</p>
<p>Fastening Pattern:</p>	<p>For slopes of 2:12 up to 21:12</p>  <p>40"</p> <p>1/2"</p> <p>1/2"</p> <p>1 1/2"</p> <p>1 1/2"</p> <p>14 1/4"</p> <p>Offset cuts</p> <p>Nails</p> <p>Nail area</p>
<p>Fastening Pattern:</p>	<p>For slopes greater than 21:12</p>  <p>Temporary second course shingles (with pattern) to determine the location for the additional 4 fasteners</p> <p>Additional 4 nails</p> <p>Asphalt roofing cement</p> <p>2"</p> <p>1"</p>

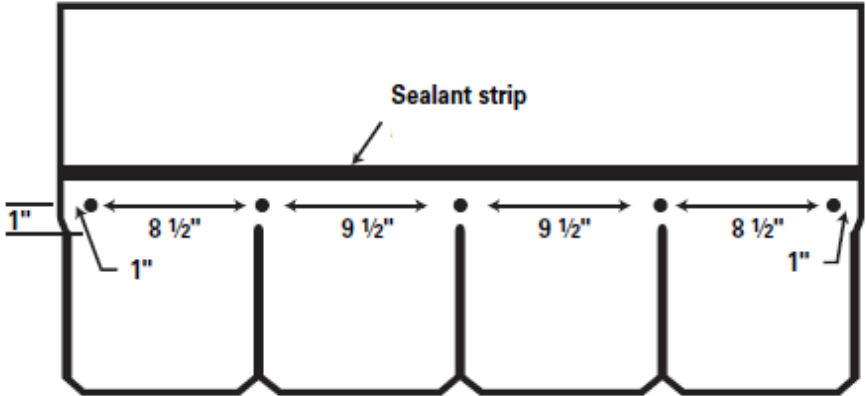
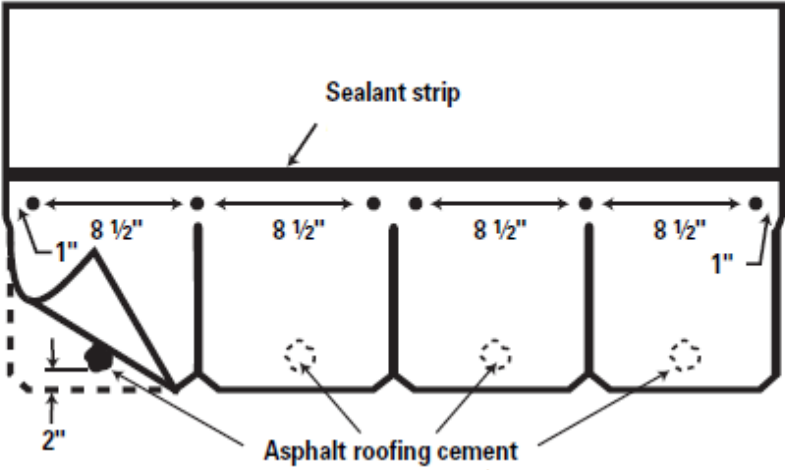
Table 13 – TruDefinition® WeatherGuard® HP

<p>Plant Location(s):</p>	<p>Houston, TX</p>
<p>Dimensions:</p>	<p>39-3/8" x 13-1/4"</p>
<p>Fastening Pattern:</p>	<p>For slopes of 2:12 up to 21:12</p> 
<p>Fastening Pattern:</p>	<p>For slopes greater than 21:12</p> 

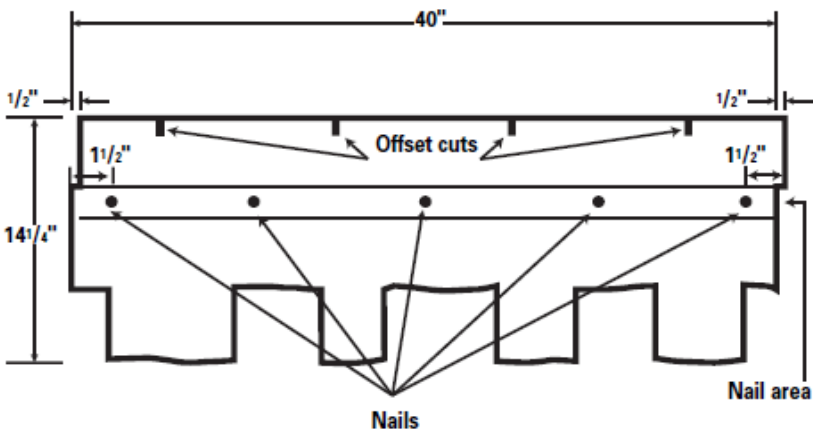
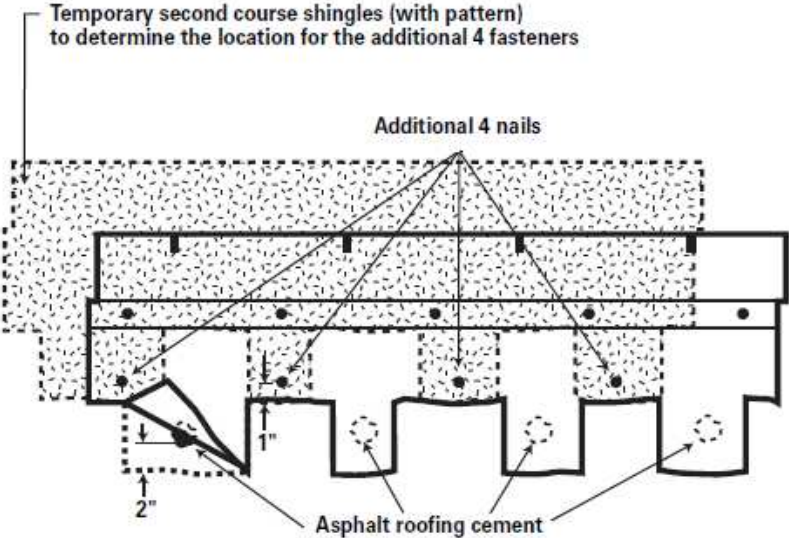
Table 13A – Devonshire™

<p>Plant Location(s):</p>	<p>Kearny, NJ</p>
<p>Dimensions:</p>	<p>40" x 13-1/4"</p>
<p>Fastening Pattern:</p>	<p>For slopes of 2:12 up to 21:12</p> 
<p>Fastening Pattern:</p>	<p>For slopes greater than 21:12</p> 

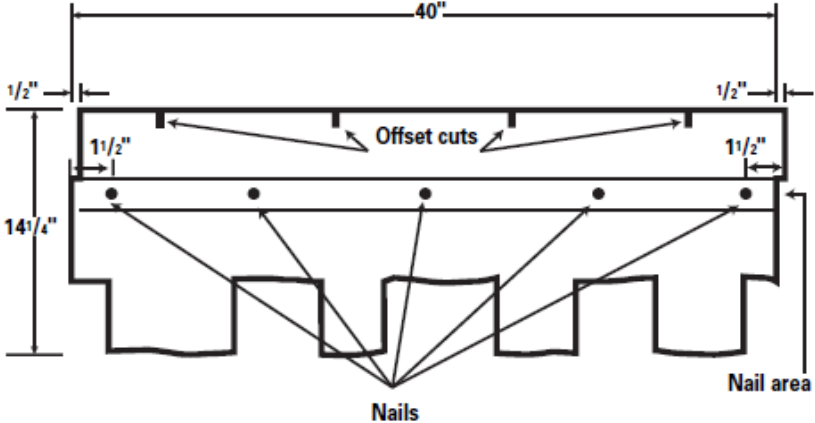
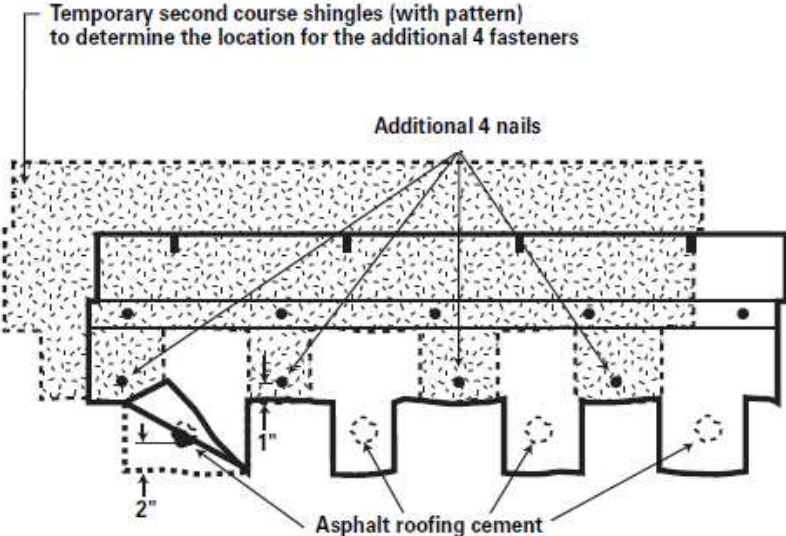
Table 14 – RIZERidge® Hip and Ridge shingles with Sealant

<p>Plant Location(s):</p>	<p>Houston, TX</p>
<p>Dimensions:</p>	<p>12" x 12"</p>
<p>Fastening Pattern:</p>	
<p>Fastening Pattern:</p>	

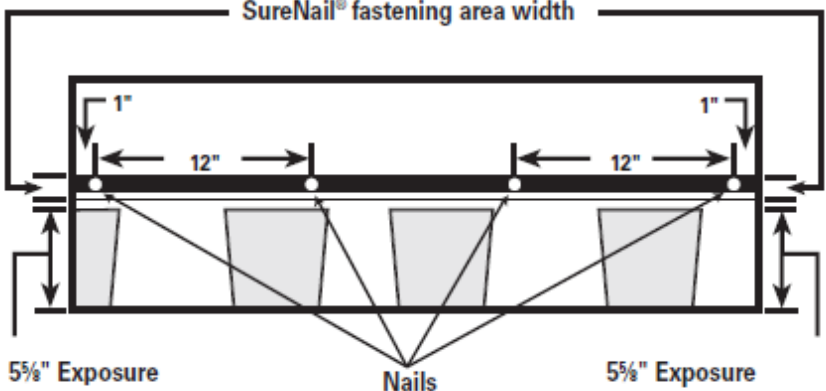
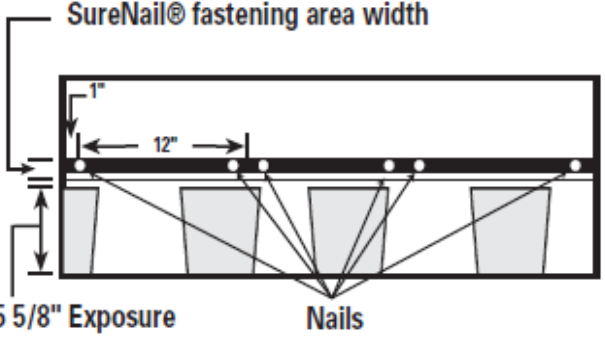
Table 14A – ProEdge®

Plant Location(s):	Atlanta, GA; Medina, OH; Denver, CO
Dimensions:	12" x 12"
Standard:	 <p>The diagram shows a cross-section of a detector. On the left side, there are two horizontal arrows pointing right, labeled "2''" and "1''". On the right side, there are two horizontal arrows pointing left, labeled "2''" and "1''". A vertical double-headed arrow on the left indicates a height of "7 1/2''". A vertical double-headed arrow in the center indicates an "Exposure 6''". A thick horizontal line is labeled "Sealant" with an arrow pointing to it from the right. Two small circles are shown on the right side of the detector.</p>

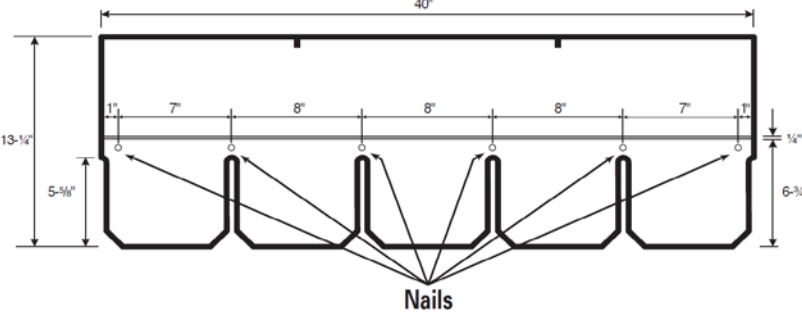
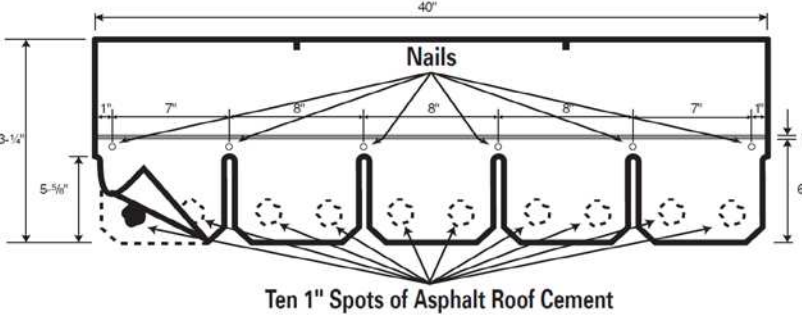
ProEdge®

Plant Location(s):	Portland, OR
Dimensions:	13-1/4" by 9-27/32"
Metric:	 <p>The diagram shows a cross-section of a detector. On the left side, there are two horizontal arrows pointing right, labeled "2''" and "1''". On the right side, there are two horizontal arrows pointing left, labeled "2''" and "1''". A vertical double-headed arrow on the left indicates a height of "7 1/2''". A vertical double-headed arrow in the center indicates an "Exposure 6 5/8''". A thick horizontal line is labeled "Sealant" with an arrow pointing to it from the right. Two small circles are shown on the right side of the detector.</p>

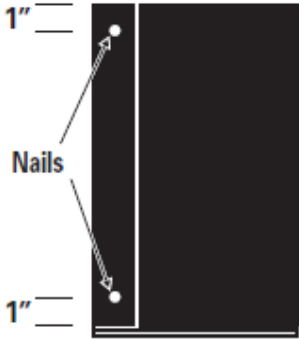
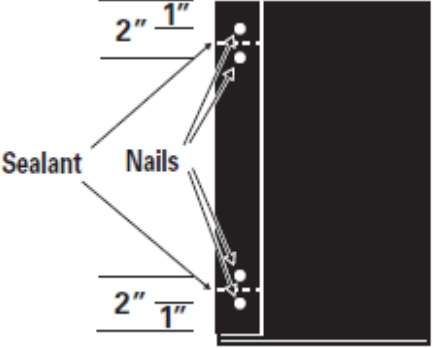
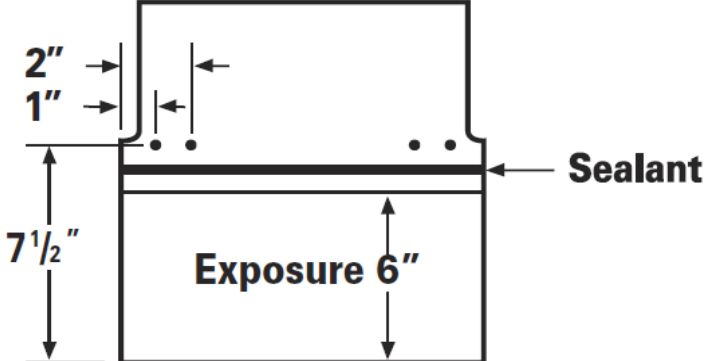
Table 14B – ProEdge® Storm®

Plant Location(s):	Denver, CO
Dimensions:	12" x 12"
Standard:	<p>The diagram shows a cross-section of a ProEdge Storm shingle. The total height of the shingle is 7 1/2 inches. The exposure (the part of the shingle that is visible) is 6 inches. There are two rows of nails. The first row is 2 inches apart, and the second row is 1 inch from the top edge. A sealant is applied to the back of the shingle, with a 1-inch offset from the top edge.</p>

Table 14C – WeatherGuard® HP Hip & Ridge

Plant Location(s):	Houston, TX
Dimensions:	12" x 12"
Standard:	<p>The diagram shows a cross-section of a WeatherGuard HP Hip & Ridge shingle. The total width is 12 inches. The total height is 12 inches, divided into a top section of 4 1/2 inches and a bottom section of 7 1/2 inches. The exposure is 6 inches. There are two rows of nails. The first row is 2 inches apart, and the second row is 1 inch from the top edge. A sealant bead is applied to the back of the shingle, with a 1/2 inch offset from the top edge and a 1/16 inch offset from the bottom edge.</p>

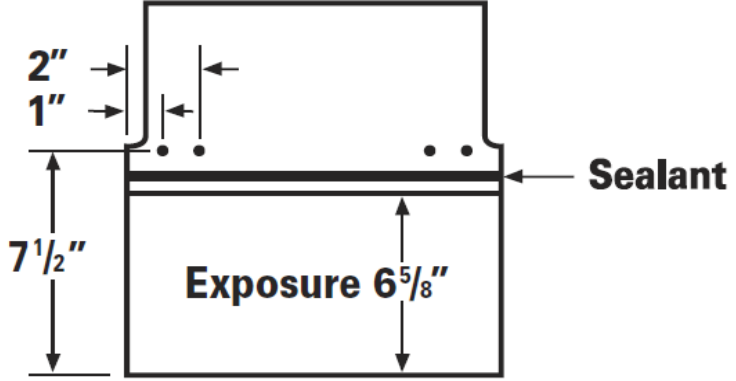
Table 14D – DuraRidge™ and Berkshire® Hip and Ridge Shingles:

Plant Location(s):	Minneapolis, MN
Dimensions:	10-5/8" x 12"
Fastening Pattern:	<div style="text-align: center;"> <p>← Prevailing Wind Direction Direction dominante du vent Dirección del viento predominante</p>  </div> <div style="text-align: center; margin-top: 20px;"> <p>Top View Vue en plan Vista superior</p>  </div>

Table 15 – WoodStart® Starter shingle

<p>Plant Location(s):</p>	<p>Compton, CA</p>
<p>Dimensions:</p>	<p>13-3/8" x 40"</p>
<p>Fastening Pattern:</p>	

Table 16 – Starter Strip Plus and Tri Built Starter Strip

<p>Plant Location(s):</p>	<p>Minneapolis, MN; Portland, OR</p>
<p>Dimensions:</p>	<p style="text-align: center;">7-3/4" x 39-3/8"</p>
<p>Fastening Pattern:</p>	

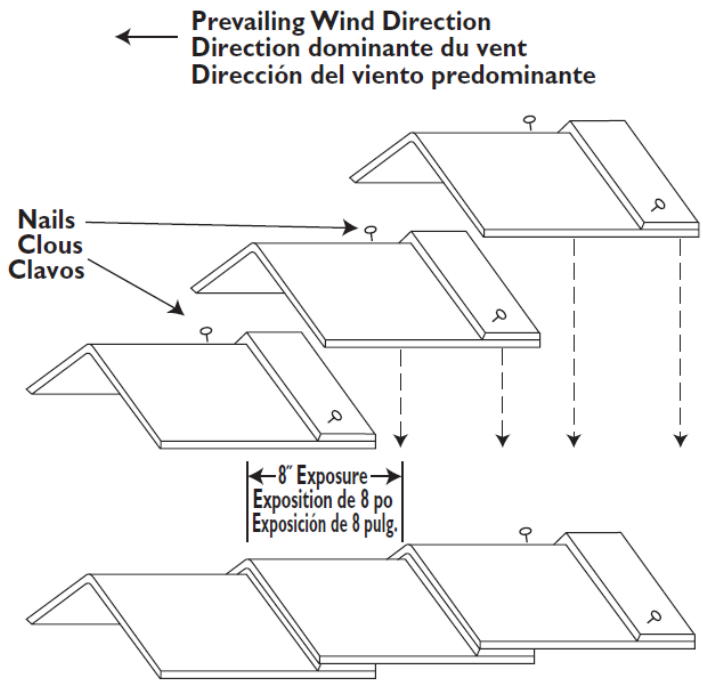
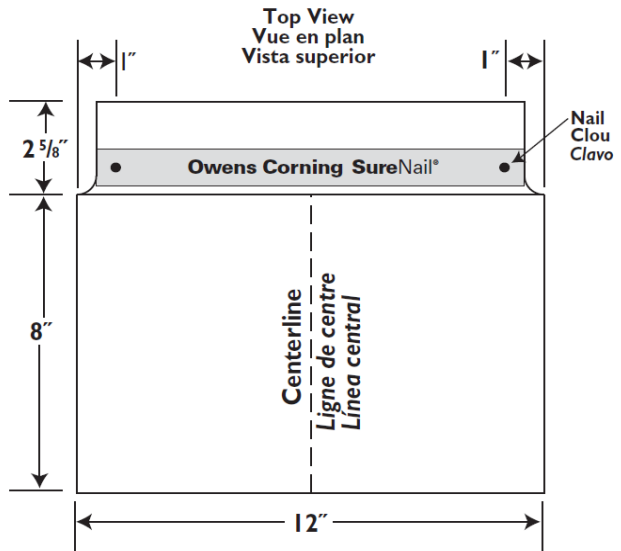
Table 17 – Starter Strip and Tri Built Starter Strip

<p>Plant Location(s):</p>	<p>Houston, TX; Portland, OR</p>
<p>Dimensions:</p>	<p>6-5/8" x 39-3/8"</p>
<p>Fastening Pattern:</p>	

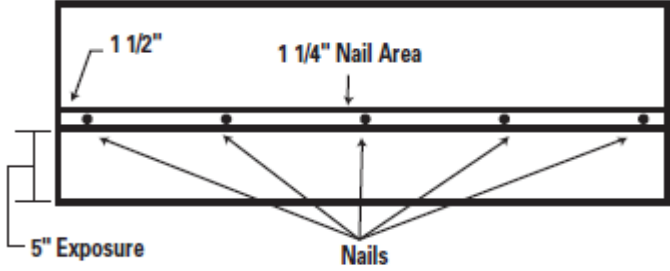
© 2017 UL LLC

This UL Evaluation Report is not an endorsement or recommendation for use of the subject and/or product described herein. This report is not the UL Listing or UL Classification Report that covers the subject product. The subject product's UL Listing or UL Classification is covered under a separate UL Report. UL disclaims all representations and warranties whether express or implied, with respect to this report and the subject or product described herein. Contents of this report may be based on data that has been generated by laboratories other than UL that are accredited as complying with ISO/IEC Standard 17025 by the International Accreditation Service (IAS) or by any other accreditation body that is a signatory to the International Laboratory Accreditation Cooperation (ILAC) Mutual Recognition Arrangement (MRA). The scope of the laboratory's accreditation shall include the specific type of testing covered in the test report. As the accuracy of any non-UL data is the responsibility of the accredited laboratory, UL does not accept responsibility for the accuracy of this data.