

Armor-Edge® All Steel Joint
(2 - 2" x 3/8" continuous cold
rolled steel bars)

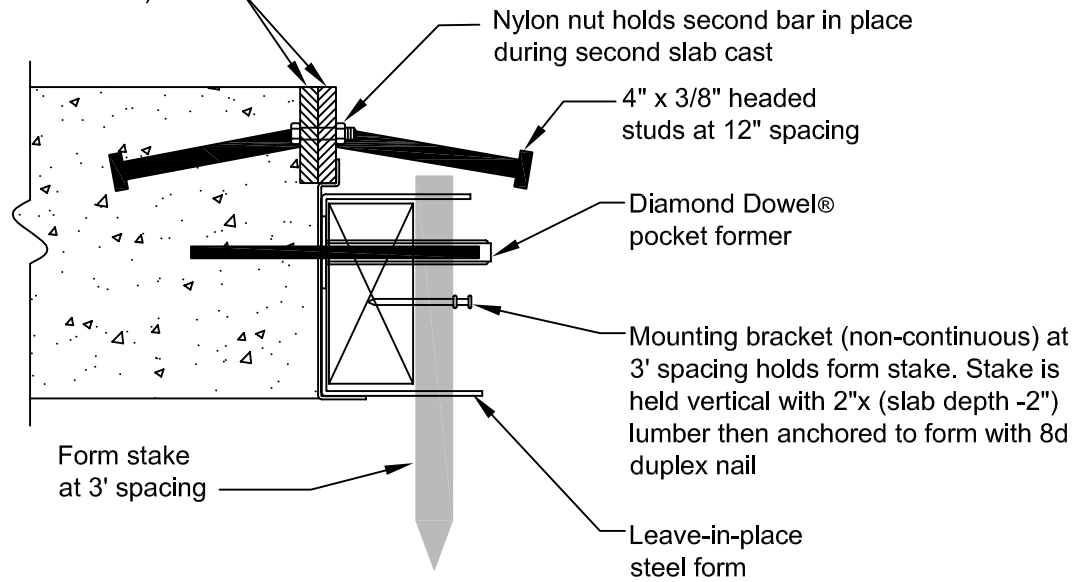

A

Form and Place Concrete

Ensure any concrete paste is removed
from top of bars during finishing

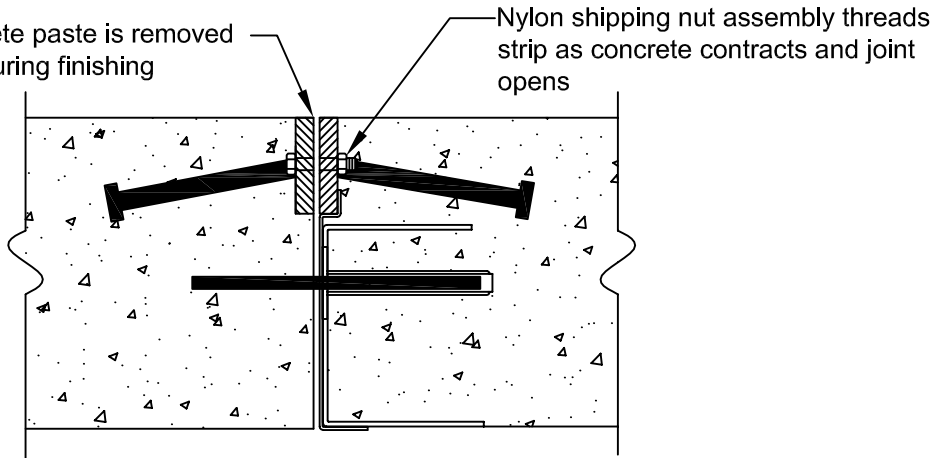

B

Place 2nd Concrete Slab

NOTES:

1. Standard length is 12' with 4" offset
2. Armor-Edge® All Steel Joint as manufactured by PNA Construction Technologies, Inc. (800) 542-0214

SHEET#
AEASJ-1

**Armor-Edge® All Steel Joint Installation Section
View at Installation Bracket-Construction Joint**

DATE	August 2007	SCALE	3"=1'-0"	DRAWN BY	
------	-------------	-------	----------	----------	--

© 2007 PNA Construction Technologies



www.pna-inc.com

Nine Dunwoody Park, Suite 111
Atlanta, GA 30338

(800) 542-0214
fax (770) 455-6803

©PNA Construction Technologies, Inc. All rights reserved. Diamond Dowel®, Armor-Edge®, Load Plate Basket® and PD3 Basket® are registered trademarks and HydraCure™ and Square™ Dowel Clip are trademarks of PNA Construction Technologies, Inc. Products shown may be covered by one or more of U.S. patents #6,775,952, #6,354,760, #5618125; Great Britain patent #1034340; Mexico patent #22942; New Zealand patent #504785; India patent #203607 and other pending patents.