

ROADWARE 10 MINUTE CONCRETE MENDER™

Application Chart

For Professional Use Only
READ ALL DIRECTIONS
CAREFULLY BEFORE USE!

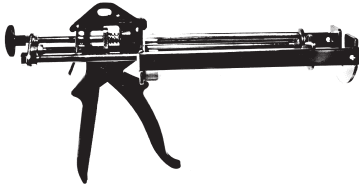

Roadware Sylcat 100. For easy dispensing of Roadware 300 x 300 ml Cartridges

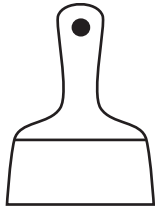

4" Taping knife for smoothing repairs



Sharp scraper for shaving off cured material.



Wire brush for cleaning cracks and spalls

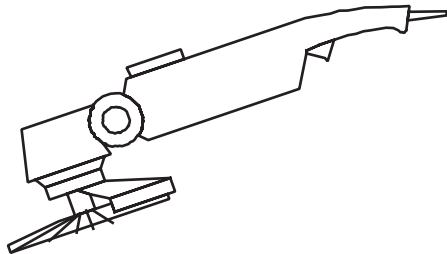

4" Grinder with a diamond blade or twisted wire wheel for cleaning cracks and spalls



Shop vacuum for cleaning out dust and debris from cracks and spalls



20 - 40 grit manufactured silica sand. Used for repairing cracks and spalls.



Gloves



Safety Glasses

Visit our web site at www.roadware.us
800-522-7623



**ROADWARE
INCORPORATED**

Cartridge Start-up Procedure

1

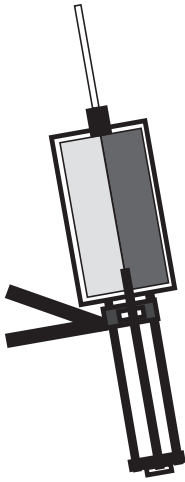

Hold cartridge upward and load into gun. Bleed off any air inside the cartridge by slightly squeezing handle and rocking the cartridge from side to side as needed to force the air bubble out through the mixer.

3



CAUTION: DO NOT POINT MIXER UPWARD AFTER MATERIAL IS FLOWING! This may cause Back-flo and clogging.

2

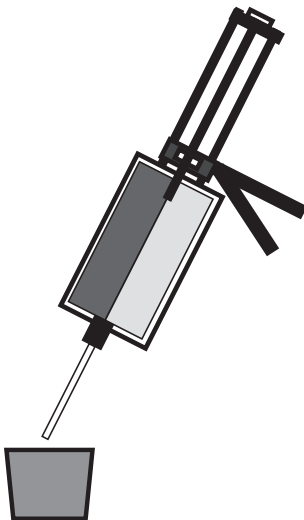

Immediately point mixer into a waste container and apply a small amount to start the material mixing.

4

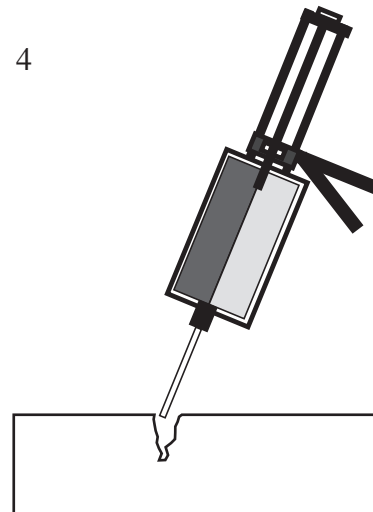

Apply material immediately, with a gentle trigger motion.

Crack Repair Spalled Control Joint Repair



1

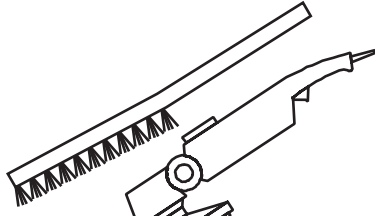

Clean repair area. Remove all dirt, oils, and loose debris.

2



Remove any dust with a vacuum or compressed air.

3

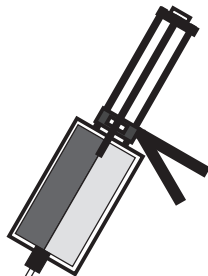

For cracks and joints greater than 1/2" deep, pre-wet with 10 Minute Concrete Mender.

4

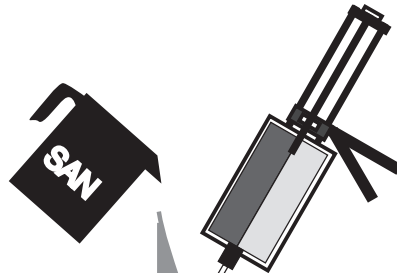

Immediately add silica sand and more 10 Minute Concrete Mender. Add enough material to slightly overfill the repair. Use enough liquid to completely saturate the sand.

5

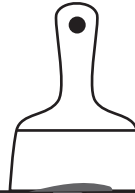

Use a taping or putty knife to smooth and shape the sand and material mixture. Leave an over band approximately 1 inch wide and 1 grain of sand thick.

6



When material cures (turns light gray in color), scrape off over banding with a sharp scraper.

7



Finished repair is open for all traffic. Any staining due to over banding will quickly wear off or can be removed with a light sanding.

Spall Repair

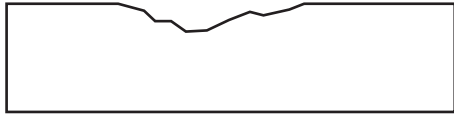

1

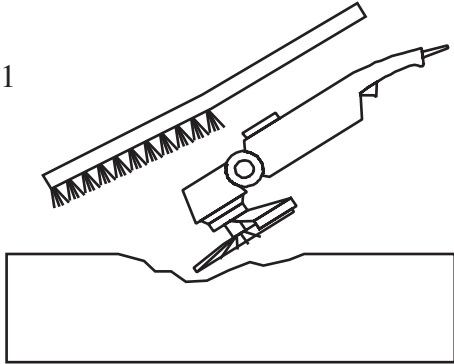

Clean repair area. Remove all dirt, oils, and loose debris.

2

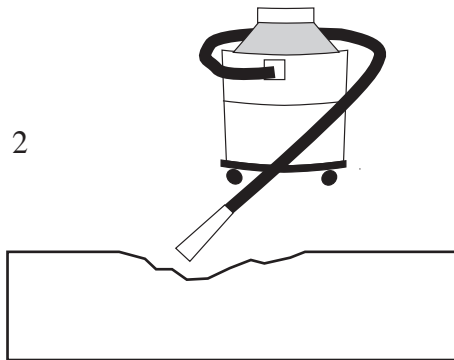

Remove any dust with a vacuum or compressed air.

3

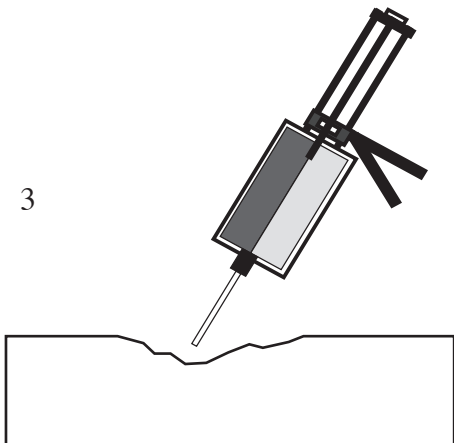

For spalls greater than 1/2" deep, pre-wet with 10 Minute Concrete Mender.

4

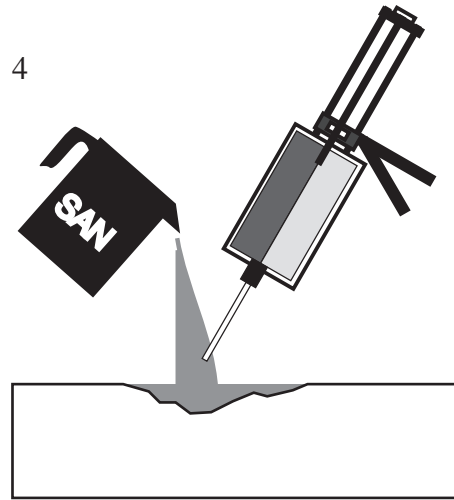

Immediately add silica sand and more 10 Minute Concrete Mender. Add enough material to slightly overfill the repair. Use enough liquid to completely saturate the sand.

5

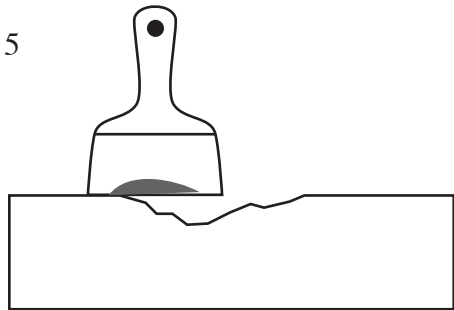

Use a taping or putty knife to smooth and shape the sand and material mixture. Leave an over band approximately 1 inch wide and 1 grain of sand thick.

6

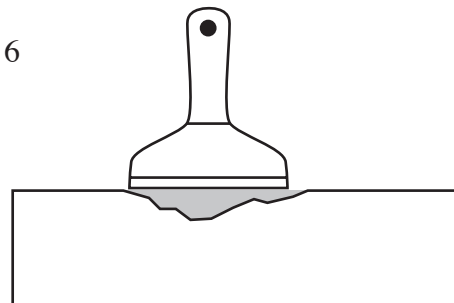

When material cures (turns light gray in color), scrape off over banding with a sharp scraper.

7



Finished repair is open for all traffic. Any staining due to over banding will quickly wear off or can be removed with a light sanding.

Recapping Partially Used Tubes

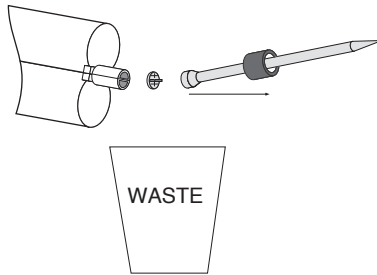

Hold cartridge sideways over a waste container and remove retaining nut, mixer, and Back-flow restrictor.

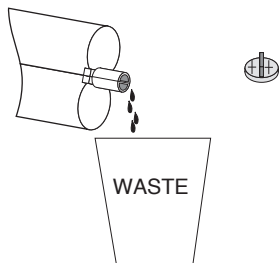

Bleed off a few drops of material to clear out any cured product. Clean or replace Back-flo restrictor.

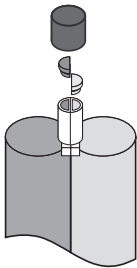

Hold cartridge upright and place D-rings into the top ports. Place overcap on cartridge.

Store upright in a cool, dry place. Material will remain usable for a varying amount of time depending on the moisture level of the storage area. Signs of moisture contamination are heavy caking and crystallization of the A-side material at the D-rings and the rear seals.

To reuse cartridge, follow normal start-up procedures.

Trouble Shooting

Every reasonable effort is made to insure every cartridge of Roadware 10 Minute Concrete Mender is easy to use and trouble free. Below is a list of possible problems, their causes and suggested solutions. For more information, please call Roadware Technical Service at 800-522-7623.

Problem: Material does not cure.

Cause: Material was not mixed properly

Solution: Make sure all start-up procedures are followed. Check for any blockage of cartridge openings.

Problem: Material is slow to cure.

Cause: Low ambient temperature

Solution: This material will set in approximately 10 minutes at 72° F. Cooler concrete and sand temperatures will increase cure time.

Problem: Cartridge is hard to pump or surges off ratio.

Possible Cause: Rear plunger is sticking. Slight leakage (mostly found in partially used cartridges) has caused the "A" (light colored) material to crystallize on the plunger causing sticking and surging.

Solution: Carefully rim the skirt of the plunger seal with a small, flat screwdriver.

Possible Cause: Material has cured inside the static mixer or Back-flo restrictor.

Solution: Replace static mixer and Back-flo restrictor if needed.

Problem: Cured material shows intensive marbling and striations.

Possible Cause: Inadequate mixing.

Solution: Follow start up procedures carefully. Make sure all air pockets are bled off before application. Use medium even strokes when applying material.

Possible Cause: Improperly placed or missing Back-flo restrictor.

Solution: Make sure the wipers in the Back-flo restrictor line up with the openings in the cartridge. Hold the static mixer in place when securing the retaining nut to prevent the Back-flo restrictor from twisting.

Problem: Material foams or bubbles when curing.

Cause: Moisture is in contact with the material.

Solution: Apply to dry surfaces only.

Clean up

Wipe tool clean with a rag before material is allowed to cure. Cured material may be removed by abrading with a wire brush or soaking in acetone, xylene, MEK, or epoxy thinner. USE EXTREME CARE WHEN WORKING WITH INDUSTRIAL SOLVENTS.

10 Minute Concrete Mender is very aggressive and will stain exposed skin. Gloves should be worn to keep material from contacting skin. In the event of skin contact, remove immediately with an industrial paint and stain hand cleaner.

SEE MSDS SHEETS FOR FURTHER INFORMATION

Disposal Methods

Empty cartridges may be disposed of with normal waste disposal methods in accordance with Federal, State, and local environmental control regulations.

Unused material is best disposed of by mixing equal parts of side A and side B and allowed to cure in a waste container. Cured material may then be disposed of with normal methods.

ACTION TO TAKE FOR SPILLS/LEAKS: Properly protected personnel should contain spill. Ventilate area, cover spill with sawdust or other absorbent material. Scoop and place in open container and treat with decontamination solution (93% water, 5% ammonia, 2% detergent). Leave open in a ventilated area for 24 hours.

DISPOSAL METHOD: Bury or landfill decontaminated waste in accordance with Federal, State, and local environmental control regulations.

SEE MSDS SHEETS FOR FURTHER INFORMATION

Visit our web site at www.roadware.us

800-522-7623



**ROADWARE
INCORPORATED**

Roadware Contact Information:

Technical Support

800-522-7623 8am- 6pm CST

After Hours Technical Support

Kelton Glewwe, National Product Manager, Cell:612-801-9200

Richard King, Vice-President, Cell: 612-810-8302

Roadware Incorporated

381 Bridgepoint Drive

South Saint Paul, MN 55075

Website:

www.concretemender.com

- **Product Instructions**
- **MSDS Sheets**
- **Application Videos**
- **Online Product Estimator**
- **Spanish Instructions**

email: sales@concretemender.com

Visit our web site at www.roadware.us

800-522-7623



**ROADWARE
INCORPORATED**