

FLEXIBLE CEMENT II™



ROADWARE FLEXIBLE CEMENT II™

Description: Roadware Flexible Cement II is a two component hydrophobic hybrid polyurethane system for maintaining control joints, repairing cracks, and filling spalls in portland concrete.

Features:

- Excellent bonding strength in a wide temperature range.
- Low moisture sensitivity, will tolerate small amounts of moisture when applied.
- Good flexibility at lower temperatures.
- Excellent chemical resistance.
- Easier cartridge mixing.
- Incredible bond strength.
- Completely cures in 15 - 20 minutes after application for heavy traffic at 70° F. Will also cure rapidly in subzero environments.
- Good resistance to chemical attack.
- Safe to use. Materials react quickly and are solvent and odor free with 100% solids and no VOC's.
- Self-leveling, excess material may be sliced off after curing.
- Bonds well to concrete, brick, tile, steel, asphalt, and wood.

Benefits:

- Long lasting repairs that accommodate harsh physical environments and thermal movement.
- No downtime, repairs are fully ready for traffic in about 20 minutes from application.
- Odor free, can be used in a wide range of indoor areas.
- Easy application. All material is self-mixed with specially designed packaging or bulk application equipment.

Uses:

- Repairing cracks, 1/8" or larger that may be subject to deflection, movement, dynamic loading, thermal expansion or contraction.
- Filling and protecting control joints.
- Repairing spalls and pop-outs in exterior or interior concrete.
- Forming and repairing bridge joint headers and nosings.
- Waterproofing.
- Filling traffic loops.
- Electrical podding.

Use ROADWARE Flex II for protecting control joints from damage due to forklifts, heavy loads, steel wheels, and high traffic.

Repairing with ROADWARE FLEXIBLE CEMENT II will...

- **STOP CHIPPING AND SPALLING**
- **MAINTAIN A SMOOTH RIDING SURFACE**
- **SEAL OUT WATER AND CHEMICALS**

Visit our web site at www.roadware.us



**ROADWARE
INCORPORATED**

ROADWARE FLEXIBLE CEMENT II™ PARKING LOT REPAIR



Visit our web site at www.roadware.us





Preparation: Shrinkage cracks are cleaned out with a diamond blade to about 1/2" deep and blown or vacuumed clear.



Application: Cracks are filled with Roadware Flexible Cement.



Finishing: In as little as 10 minutes, Repairs are shaved clean with a razor scrapper.

Visit our web site at www.roadware.us



Flexible Cement II™ Crack Repair

Use Roadware Flexible Cement II™ to fill non-moving cracks in exterior concrete slabs and decks.

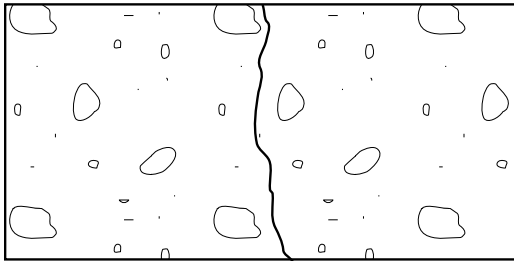
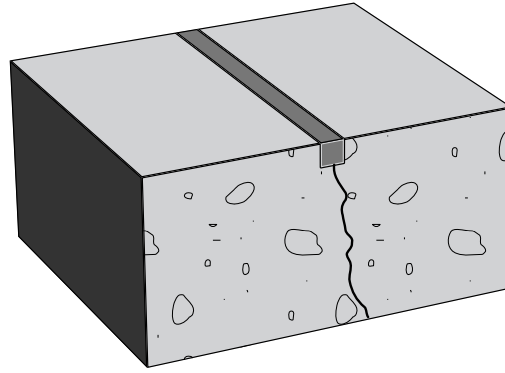

Hairline crack in concrete deck or slab.

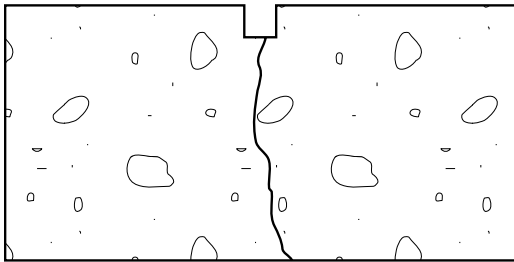

Rout out a small channel of concrete at the top of the crack. Approximately 0.25" x 0.25".

Prepare surface in accordance to material instructions.

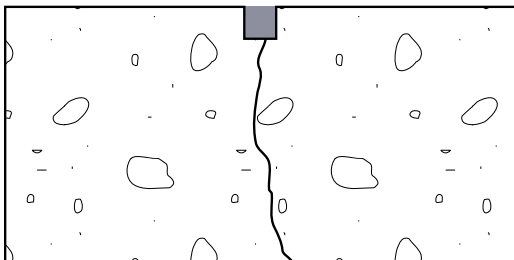

Fill void with Roadware Flexible Cement II™

ROADWARE INCORPORATED
2100 Wentworth Avenue
South Saint Paul, MN 55075
651-457-6122
800-522-7623

Visit our web site at www.roadware.us



ROADWARE FLEXIBLE CEMENT II RECOMMENDED CONTROL JOINT DETAIL

1. Goal: to protect the control joint sidewalls from damage due to heavy traffic from forklifts and hard wheels.

Secondary Goals: seal out dirt and debris, allow for slight slab movement, stop chemical intrusion.

2. Preparation: mechanically clean all surfaces with a concrete saw blade, diamond blade, wire wheel, or other device. Remove all dust with a vacuum or compressed air.

3. Joint profile: recommended material depth is 1/3 the depth of the slab or the full depth of the saw cut. This will allow for maximum protection of the joint sidewalls and heavy traffic support.

4. Filling: assemble cartridge and dispense according to directions. Fill to just slightly above grade. Bulk material should be applied with an approved dual component mixing pump.

5. Finishing: after material cures in 10 - 20 minutes and is slightly tacky, cut off excess material with a razor sharp scrapper.

6. Maintenance and repair: remove affected material and repeat steps 2,3,4,5.

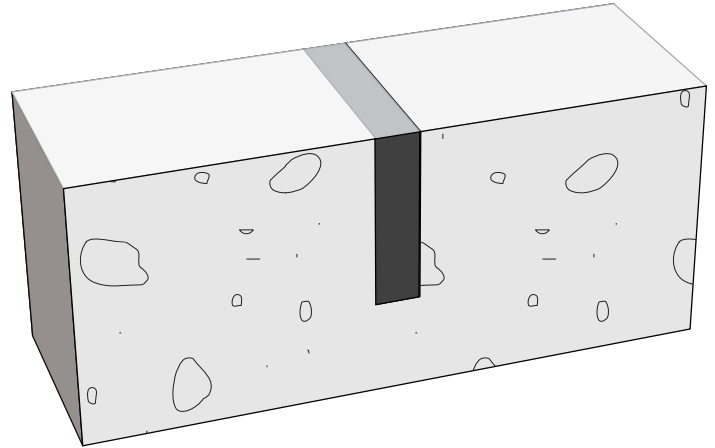

DETAIL 1: FULL DEPTH. FOR MAXIMUM PROTECTION UNDER HEAVY TRAFFIC.

ROADWARE FLEXIBLE CEMENT II™ LOOP SEALANT APPLICATION

Roadware FLEXIBLE CEMENT II™ makes an excellent loop sealant. Simply lay electrical wires in the saw cut and flood with material supplied in easy to use duplex cartridges. In 10-15 minutes, you will have a tough flexible seal that will protect the wiring from moisture, dirt, rocks and heavy traffic.

For more information contact Roadware, Inc. at 800-522-7623

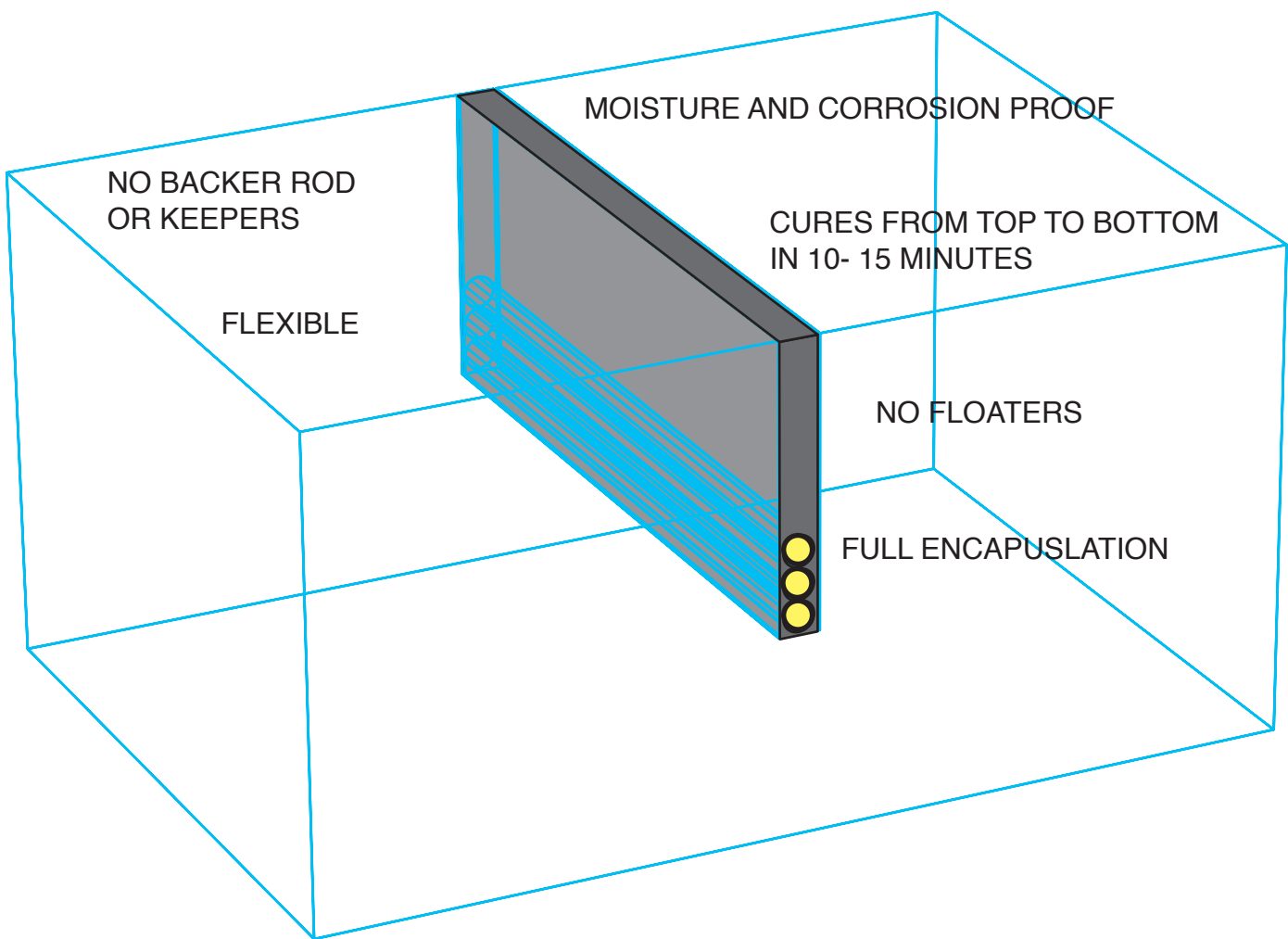

Visit our web site at www.roadware.us



**ROADWARE
INCORPORATED**