



## ICC-ES Evaluation Report ESR-1056

Reissued March 2023

This report is subject to renewal March 2024.

**DIVISION: 04 00 00—MASONRY**  
**Section: 04 05 19.16—Masonry Anchors**

**REPORT HOLDER:**

**SIMPSON STRONG-TIE COMPANY INC.**

**EVALUATION SUBJECT:**

**SIMPSON STRONG-TIE TITEN HD® SCREW ANCHORS**

### 1.0 EVALUATION SCOPE

**Compliance with the following codes:**

- 2021, 2018, 2015 and 2012 *International Building Code*® (IBC)
- 2021, 2018, 2015 and 2012 *International Residential Code*® (IRC)

For evaluation for compliance with codes adopted by the Los Angeles Department of Building and Safety (LADBS), see [ESR-1056 LABC and LARC supplement](#).

**Property evaluated:**

Structural

### 2.0 USES

The Titen HD® screw anchor is for installation in predrilled holes to anchor building components to fully grouted or hollow (ungrouted) concrete masonry wall construction.

The Titen HD screw anchors are alternatives to cast-in-place anchors described in Section 8.1.3 (2016 or 2013 edition), or Section 2.1.4 (2011 edition) of [TMS 402](#) as referenced in Section [2107.1](#) of the IBC.

The anchors are permitted to be used in structures regulated by the IRC, provided an engineered design is submitted in accordance with IRC Section [R301.1.3](#).

### 3.0 DESCRIPTION

#### 3.1 Materials:

**3.1.1 Titen HD Screw Anchor:** The Titen HD screw anchor is a threaded screw anchor available with a hex-washer head or a countersunk head in carbon steel and in stainless steel. The carbon steel Titen HD screw anchors are manufactured from heat-treated steel complying with [SAE J403](#) Grade 10B21, and has either an electrodeposited coating of zinc in accordance with [ASTM B633](#), Service Condition SC1, Type III; or a mechanically deposited coating of zinc in accordance with [ASTM B695](#), Class 65,

Type I. The stainless steel Titen HD screw anchors are manufactured from AISI Type 304 or AISI Type 316 stainless steel material. The leading hardened carbon steel helical-coil cutting thread is made of carbon steel complying with the manufacturer's quality documentation.

Carbon steel Titen HD screw anchors with electrodeposited zinc coating and a hex-washer head are available with nominal 1/4-, 3/8-, 1/2-, 5/8-, and 3/4-inch (6.4, 9.5, 12.7, 15.9 and 19.1 mm) shank diameters. Carbon steel Titen HD screw anchors with mechanically deposited zinc coating and a hex-washer head are available with nominal 3/8-, 1/2-, 5/8-, and 3/4-inch (9.5, 12.7, 15.9 and 19.1 mm) shank diameters. Stainless steel Titen HD screw anchors with a hex-washer head are available with nominal 3/8-, 1/2-, 5/8-, and 3/4-inch (9.5, 12.7, 15.9 and 19.1 mm) shank diameters. Carbon steel Titen HD screw anchors with a countersunk head are available with nominal 1/4- and 3/8-inch (6.4 and 9.5 mm) shank diameters. Stainless steel Titen HD screw anchor with a countersunk head is available with nominal 3/8-inch (9.5 mm) shank diameter. Refer to [Figure 1A](#), [1B](#), [1C](#) and [1D](#) for an illustration of a typical screw anchor.

**3.1.2 Grout-filled Concrete Masonry:** The specified compressive strength of masonry at the time of installation,  $f'_m$ , at 28 days must be a minimum of 1,500 psi (10.3 MPa) for carbon steel Titen HD screw anchors and a minimum of 2,000 psi (13.9 MPa) for stainless steel Titen HD screw anchors, when installed in the face of fully grouted CMU and top of grout-filled CMU construction. The specified compressive strength of masonry at the time of installation,  $f'_m$ , at 28 days must be a minimum of 2,000 psi (13.8 MPa) for carbon steel Titen HD screw anchors when installed in the end of fully grouted CMU. Fully grouted masonry walls must be constructed from the following materials:

**3.1.2.1 Concrete Masonry Units (CMUs):** CMUs must be minimum Grade N, Type II, lightweight, medium-weight, or normal-weight, closed-end, conforming to [ASTM C90](#). The minimum allowable nominal size of the CMU must be 8 inches (203.2 mm) wide by 8 inches (203.2 mm) high by 16 inches (406.4 mm) long.

**3.1.2.2 Grout:** Grout must comply with IBC Section [2103.3](#) (2021, 2018 and 2015 IBC), [2013.13](#) (2012 IBC), or Section [R606.2.12](#) (2021 and 2018 IRC), [R609.2.11](#) (2015 IRC), Section [R609.1.1](#) (2012 IRC), as applicable. Alternatively, the grout must have a minimum compressive strength when tested in accordance with [ASTM C1019](#) equal to its specified strength, but not less than 2,000 psi (13.8 MPa).

**3.1.2.3 Mortar:** Mortar must be Type M or S in compliance with IBC Section [2103.2.1](#) (2021, 2018 and 2015 IBC), Section [2103.9](#) (2012 IBC), or IRC Section [R606.2.8](#) (2021 and 2018 IRC), [R606.2.7](#) (2015 IRC), [R607.1](#) (2012 IRC), as applicable.

**3.1.3 Hollow (UngROUTED) Concrete Masonry:** The compressive strength of masonry at the time of installation,  $f_m$ , at 28 days must be a minimum of 2,000 psi (10.3 MPa). Hollow masonry walls must comply with [Chapter 21](#) of the IBC and must be constructed from the following materials:

**3.1.3.1 Concrete Masonry Units (CMUs):** CMUs must be minimum Grade N, Type II, lightweight, medium-weight, or normal-weight, closed-end, conforming to ASTM C90. The minimum allowable nominal size of the CMU must be 8 inches (203.2 mm) wide by 8 inches (203.2 mm) high by 16 inches (406.4 mm) long.

**3.1.3.2 Mortar:** Mortar must be Type M or S in compliance with IBC Section [2103.2.1](#) (2021, 2018 and 2015 IBC), Section [2103.9](#) (2012 IBC), or IRC Section [R606.2.8](#) (2021 and 2018 IRC), [R606.2.7](#) (2015 IRC), [R607.1](#) (2012 IRC), as applicable.

## 3.2 Design:

**3.2.1 General:** Anchors described in this report are assigned allowable tension and shear loads for designs based on allowable stress design (working stress design). Use of the anchors to resist vibratory and moving loads, such as those produced by reciprocating engines, cranes and vehicles, is beyond the scope of this report.

**3.2.2 Design of Anchors Installed in CMU Masonry:** Allowable tension and shear loads for anchors installed in the face of fully grouted CMU masonry are noted in [Table 1](#) for structures complying with the IBC or IRC. The allowable tension and shear loads are for anchors installed in the grouted cells, the center web of CMU units, and horizontal mortared bed joints of fully grouted CMU masonry construction. Allowable loads for anchors installed in the vertical head joint of the CMU units are outside the scope of this report. Edge and end distances, and spacing requirements for anchors installed in the face of fully grouted CMU masonry, as shown in [Figure 2](#), are noted in [Table 1](#). Allowable load reduction factors for anchors installed at reduced edge distances, and reduced spacing, are noted in [Tables 2](#) and [3](#).

Allowable tension and shear loads for 1/2-inch and 5/8-inch (12.7 mm and 15.9 mm) carbon steel Titen HD screw anchors installed in the top of fully grouted concrete masonry (CMU grouted cores and CMU webs), are noted in [Table 4](#) for anchors installed in structures complying with the IBC or IRC.

Allowable tension and shear loads for 3/8-inch, 1/2-inch, 5/8-inch and 3/4-inch (9.5 mm, 12.7 mm, 15.9 mm and 19.1 mm) stainless steel Titen HD screw anchors installed in the face of hollow masonry are noted in [Table 5](#) for anchors installed in structures complying with the IBC or IRC. Edge and end distances, and spacing requirements for anchors installed in the face of hollow CMU masonry, as shown in [Figure 4](#), are noted in [Table 5](#). Allowable load reduction factors for anchors installed at reduced edge distances, and reduced spacing, are noted in [Tables 6](#) and [7](#).

Allowable tension and shear loads for 1/4-inch and 3/8-inch (6.4 mm and 9.5 mm) carbon steel Titen HD screw anchors installed in the end of fully grouted and hollow concrete masonry are noted in [Tables 8](#) and [9](#), respectively, for anchors installed in structures complying with the IBC or IRC. Edge and end distances, and spacing requirements for anchors installed in the end of fully grouted and hollow CMU

masonry, as shown in [Figures 5 and 6](#), are noted in [Tables 8 and 9](#), respectively.

Allowable loads for anchors installed in the face or end of fully grouted CMU masonry walls subjected to combined shear and tension forces must be determined by the following equation:

$$\left(\frac{P_s}{P_t}\right) + \left(\frac{V_s}{V_t}\right) \leq 1.0$$

where:

- $P_s$  = Applied service tension load.
- $P_t$  = Allowable service tension load.
- $V_s$  = Applied service shear load.
- $V_t$  = Allowable service shear load.

## 4.0 INSTALLATION

Titen HD screw anchors must be installed by drilling a pilot hole into the substrate using a handheld electro-pneumatic rotary hammer drill with a carbide-tipped drill bit conforming to [ANSI B212.15-1994](#). The pilot hole must have the same diameter as the nominal diameter of the anchor. Rotary hammer drill must be set to rotation-only mode when drilling into hollow (ungROUTED) CMU. The hole is drilled to the specified embedment depth plus 1/2 inch (12.7 mm). Dust and debris in the hole must be removed by using oil-free compressed air. The Titen HD screw anchor must be installed into the hole to the required embedment using a socket wrench or powered impact wrench.

**4.1 Installation in Fully Grouted CMU Masonry:** Anchors installed in the face of fully grouted CMU construction must be limited to the face shell of the CMU unit (center web and grouted cores) and the horizontal mortared bed joints, as indicated by the shaded areas in [Figure 2](#). Anchors installed in a T-joint, the mortared head joint, or the end webs of a CMU unit, as indicated in the non-shaded areas in [Figure 2](#), are outside the scope of this report. For anchors installed in the end of fully grouted CMU construction, anchors may be installed in grouted cores or the horizontal mortared bed joints as shown in [Figure 5](#).

For anchors installed in the top of fully grouted concrete masonry (CMU grouted cores and CMU webs), anchor location must comply with the minimum edge and end distances noted in [Table 4](#) and shown in [Figure 3](#). Anchors installed in the mortared head joint are outside the scope of this report.

**4.2 Installation in Hollow CMU Masonry:** Anchors installed in the face of hollow CMU construction must be limited to the face shell of the CMU unit (center web and hollow cores) as indicated by the shaded areas in [Figure 4](#). Anchors installed in a horizontal mortared bed joint, T-joint, the mortared head joint, or the end webs of a CMU unit, as indicated in the non-shaded areas in [Figure 4](#), are outside the scope of this report.

For anchors installed in the end of hollow CMU construction, anchors location must comply with the minimum edge and end distances noted in [Table 9](#) and as shown in [Figure 6](#). Anchors installed in a horizontal mortared bed joint, as indicated by the circled areas of [Figure 6](#), are outside the scope of this report.

## 4.3 Installation with Special Inspection (When Required):

Anchors must be installed with special inspection. For the IBC and IRC, special inspection must conform to Sections [1704](#) and [1705](#) of the IBC.

For fasteners installed with special inspection, the following items, as applicable, must be inspected: fastener

type and dimensions; masonry unit type and compliance with ASTM C90; grout and mortar compressive strengths, and (when required) masonry prism compressive strength; drill bit size and compliance with ANSI B212.15-1994; and fastener embedment, spacing, and edge (and end) distances. The special inspector must inspect and verify that anchor installation complies with this evaluation report and Simpson Strong-Tie Company's published installation instructions.

## 5.0 CONDITIONS OF USE

The Titen HD Screw Anchors described in this report comply with, or are suitable alternatives to what is specified in, the codes listed in Section 1.0 of this report, subject to the following conditions:

- 5.1 Anchors are identified and installed in accordance with this report and the manufacturer's published installation instructions. In case of conflict, this report governs.
- 5.2 **Grouted Masonry under IBC or IRC:** Anchors installed in the face, top or end of fully grouted CMU masonry may be used to resist short-term loading due to wind or seismic forces in structures assigned to Seismic Design Categories A through F under the IBC.
 

When using the basic load combinations in accordance with 2021 IBC Section 1605.1, or 2018, 2015 and 2012 IBC Section 1605.3.1, allowable loads are not permitted to be increased for seismic or wind loading. The allowable stress increase or load reduction is not permitted under the 2021, 2018, 2015 and 2012 codes.
- 5.3 **Hollow Masonry under IBC or IRC:** Anchors installed in the face or end of hollow CMU masonry may be used to resist short-term loading due to wind or seismic forces in structures assigned to Seismic Design Categories A and B only under the IBC. The allowable loads or load combinations for the anchors shall not be adjusted for anchors subjected to wind or seismic loads.
- 5.4 **Fatigue and Shock Loading:** Since an ICC-ES acceptance criteria for evaluating data to determine the performance of screw anchors subjected to fatigue or shock loading is unavailable at this time, the use of these anchors under these conditions is beyond the scope of this report.
- 5.5 **Fire-resistive Construction:** Where not otherwise prohibited by the applicable code, anchors are permitted for use with fire-resistance-rated construction provided that at least one of the following conditions is fulfilled:
  - Anchors are used to resist wind or seismic forces only.
  - Anchors that support fire-resistance-rated construction or gravity load-bearing structural elements are within a fire-resistance-rated envelope or a fire-resistance-rated membrane, are protected by approved fire-resistance-rated materials, or have been evaluated for resistance to fire exposure in accordance with recognized standards.
  - Anchors are used to support nonstructural elements.
- 5.6 **Cracked Masonry:** Since an ICC-ES acceptance criteria for evaluating the performance of screw anchors in cracked masonry is unavailable at this time,

the use of anchors is limited to installation in uncracked masonry. Cracking occurs when  $f_t > f_r$  due to service loads or deformations.

- 5.7 Anchors are installed in substrates in holes predrilled with carbide-tipped masonry drill bits complying with ANSI B212.15-1994, and having the same diameter as the nominal diameter of the anchor. Rotary hammer drill must be set to rotation-only mode when drilling into hollow (ungrouted) CMU.
- 5.8 Calculations demonstrating that the applied loads are less than the allowable loads described in this report, must be submitted to the building official. The calculations must be prepared by a registered design professional where required by the statutes of the jurisdiction in which the project is to be constructed.
- 5.9 Special inspection, when required, must be provided in accordance with Section 4.3.
- 5.10 Use of carbon steel Titen HD screw anchors with electrodeposited zinc coating in accordance with ASTM B633 as described in Section 3.1.1 is limited to dry, interior locations.
- 5.11 Use of carbon steel Titen HD screw anchors with mechanically deposited zinc coating in accordance with ASTM B695 as described in Section 3.1.1 is permitted for exterior exposure or damp environments, and for interior locations where anchors are in contact with preservative-treated and fire-retardant-treated wood.
- 5.12 Use of stainless steel Titen HD screw anchors as described in Section 3.1.1. is permitted for exterior exposure or damp environments.
- 5.13 The Titen HD screw anchors are manufactured by Simpson Strong-Tie Company under a quality control program with inspections by ICC-ES.

## 6.0 EVIDENCE SUBMITTED

Data in accordance with the ICC-ES Acceptance Criteria for Predrilled Fasteners (Screw Anchors) in Masonry (AC106), dated March 2018 (Editorially revised December 2020), including the following optional tests:

- 6.1 Anchors installed in the face of fully grouted CMU masonry wall construction: Effects of edge distance on tension and shear performance (Test Series 4, 5, 13, and 14 of AC106), and seismic performance tests (Section 4.6 of AC106).
- 6.2 Anchors installed in the top of fully grouted CMU masonry wall construction with a minimum 1<sup>3</sup>/<sub>4</sub>-inch (44 mm) edge distance: Effects on tension and shear performance (Test Series 4 and 13 of AC106), and seismic performance tests (Section 4.6 of AC106).
- 6.3 Anchors installed in the face of hollow CMU masonry wall construction with a minimum edge distance: Effects on tension and shear performance (Test Series 4 and 13 of AC106).
- 6.4 Anchors installed in the end of fully grouted CMU masonry wall construction with a minimum edge distance: Effects on tension and shear performance (Test Series 5 and 14 of AC106), and seismic performance tests (Section 4.6 of AC106).
- 6.5 Anchors installed in the end of hollow CMU masonry wall construction with a minimum edge distance: Effects on tension and shear performance (Test Series 5 and 14 of AC106).

## 7.0 IDENTIFICATION

- 7.1 The ICC-ES mark of conformity, electronic labeling, or the evaluation report number (ICC-ES ESR-1056) along with the name, registered trademark, or registered logo of the report holder must be included in the product label.
- 7.2 In addition, Titen HD screw anchor packaging is marked with the Simpson Strong-Tie Company name; product name (Titen HD); anchor diameter and length; anchor type; and the evaluation report number (ESR-1056). In addition, the  $\neq$  symbol and anchor length (in inches) is stamped on the head of each screw anchor.

- 7.3 The report holder's contact information is the following:

**SIMPSON STRONG-TIE COMPANY INC.**  
**5956 WEST LAS POSITAS BOULEVARD**  
**PLEASANTON, CALIFORNIA 94588**  
**(800) 925-5099**  
[www.strongtie.com](http://www.strongtie.com)



FIGURE 1A—TYPICAL HEX-WASHER HEAD CARBON STEEL TITEN HD SCREW ANCHOR



FIGURE 1B—TYPICAL HEX-WASHER HEAD STAINLESS STEEL TITEN HD SCREW ANCHOR



FIGURE 1C—TYPICAL COUNTERSUNK HEAD CARBON STEEL TITEN HD SCREW ANCHOR



FIGURE 1D—TYPICAL COUNTERSUNK HEAD STAINLESS STEEL TITEN HD SCREW ANCHOR

**TABLE 1—IBC AND IRC ALLOWABLE TENSION AND SHEAR LOADS FOR TITEN HD SCREW ANCHORS INSTALLED IN THE FACE OF FULLY GROUTED CMU MASONRY CONSTRUCTION<sup>1</sup>**

ANCHOR MATERIAL	ANCHOR DIA. <sup>2</sup> (in.)	DRILL BIT DIA. (in.)	MIN. EMBED. <sup>3</sup> (in.)	ANCHOR LOCATION <sup>4</sup> (in.)				ALLOWABLE LOADS BASED ON ANCHORS INSTALLED AT DISTANCES ≥ CRITICAL EDGE DISTANCE, $C_{crit}$ AND CRITICAL SPACING, $S_{crit}$ <sup>5</sup> (lbf)	
				Edge Distance		Spacing		Tension	Shear
				Critical, $C_{crit}$	Minimum, $C_{min}$	Critical, $S_{crit}$	Minimum, $S_{min}$		
CARBON STEEL	1/4	1/4	2 1/2	4	1 1/4	4	2	410	500
	3/8	3/8	2 3/4	12	4	6	3	480	870
	1/2	1/2	3 1/2	12	4	8	4	690	1,385
	5/8	5/8	4 1/2	12	4	10	5	1,060	2,085
	3/4	3/4	5 1/2	12	4	12	6	1,600	3,000
STAINLESS STEEL	3/8	3/8	2 3/4	12	4	8	4	425	570
	1/2	1/2	3 1/2	12	4	8	4	665	990
	5/8	5/8	4 1/2	12	4	8	4	770	985
	3/4	3/4	5 1/2	12	4	8	4	1040	890

For SI: 1 inch = 25.4 mm, 1 psi = 6.89 kPa, 1 lbf = 4.48 N.

<sup>1</sup> Anchors must be installed a minimum of 1 1/4 inches from vertical head joints and T-joints. Refer to [Figure 2](#) for permitted and prohibited anchor installation locations.

<sup>2</sup> The drill bit diameter must be equal to the nominal diameter of the anchor. Anchor installation – must comply with Section 4.0 of this report.

<sup>3</sup> Embedment depth is measured from the outside face of the masonry.

<sup>4</sup> Critical and minimum edge distances,  $C_{crit}$  and  $C_{min}$ , respectively, must comply with this table. Refer to [Figure 2](#). Critical and minimum spacing,  $S_{crit}$  and  $S_{min}$ , respectively, must comply with this table. Critical and minimum edge and spacing distances are valid for anchors resisting tension or shear loads. Refer to [Table 2](#) for allowable tension and shear load reduction factors for anchors installed between critical and minimum edge distances, and to [Table 3](#) for anchors installed between critical and minimum spacing.

<sup>5</sup> Tabulated allowable loads are based on a safety factor of 5.0.

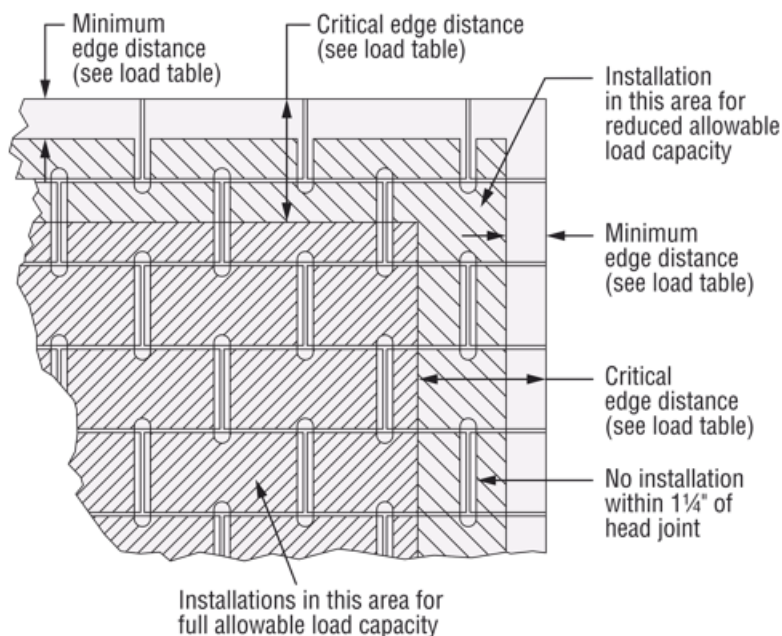

**FIGURE 2—CARBON STEEL AND STAINLESS STEEL TITEN HD SCREW ANCHOR INSTALLED IN THE FACE OF GROUT-FILLED CMU (CONCRETE MANSORY UNIT) WALL CONSTRUCTION (Refer to Table 1, 2, and 3)**

**TABLE 2—LOAD REDUCTION FACTORS FOR TITEN HD SCREW ANCHORS INSTALLED BETWEEN CRITICAL AND MINIMUM EDGE DISTANCES (Anchors Installed in the Face of Grout-filled CMU Masonry)<sup>1,2,3</sup>**

ANCHOR MATERIAL	ANCHOR DIAMETER (in)	MINIMUM EMBEDMENT DEPTH (in)	LOAD REDUCTION FACTORS FOR ANCHORS INSTALLED AT:					
			Critical Edge Distance, $c_{crit}$	Minimum Edge Distance, $c_{min}$				
				Tension or Shear Load	Tension Load	Shear Load Acting:		
						Towards an Edge	Away from an Edge	Parallel to an Edge
CARBON STEEL	1/4	2 1/2	1.0	0.77	0.71	0.71	0.58	
	3/8	2 3/4	1.0	1.0	0.58	0.89	0.77	
	1/2	3 1/2	1.0	1.0	0.38	0.79	0.48	
	5/8	4 1/2	1.0	0.83	0.30	0.58	0.46	
	3/4	5 1/2	1.0	0.66	0.21	0.38	0.44	
STAINLESS STEEL	3/8	2 3/4	1.0	0.80	0.93	0.93	0.88	
	1/2	3 1/2	1.0	0.81	0.48	0.48	0.56	
	5/8	4 1/2	1.0	1.0	0.66	0.66	0.65	
	3/4	5 1/2	1.0	1.0	0.69	0.69	0.84	

For SI: 1 inch = 25.4 mm.

<sup>1</sup>The load reduction factors in this table are applicable to the allowable loads shown in Table 1.

<sup>2</sup>Reduction factors are cumulative. Multiple reduction factors for more than one spacing or edge distance are calculated separately and multiplied.

<sup>3</sup>Load reduction factors for anchors loaded in tension or shear with edge distances between critical and minimum are obtained by linear interpolation.

**TABLE 3—LOAD REDUCTION FACTORS FOR TITEN HD SCREW ANCHORS INSTALLED BETWEEN CRITICAL AND MINIMUM SPACING (Anchors Installed in the Face of Grout-filled CMU Masonry)<sup>1,2,3</sup>**

ANCHOR MATERIAL	ANCHOR DIAMETER (in)	MINIMUM EMBEDMENT DEPTH (in)	LOAD REDUCTION FACTORS FOR ANCHORS INSTALLED AT:		
			Critical Spacing, $s_{crit}$	Minimum Spacing, $s_{min}$	
				Tension or Shear Load	Tension Load
CARBON STEEL	1/4	2 1/2	1.0	0.66	0.87
	3/8	2 3/4	1.0	0.87	0.62
	1/2	3 1/2	1.0	0.69	0.62
	5/8	4 1/2	1.0	0.59	0.62
	3/4	5 1/2	1.0	0.50	0.62
STAINLESS STEEL	3/8	2 3/4	1.0	0.81	1.0
	1/2	3 1/2	1.0	0.79	0.86
	5/8	4 1/2	1.0	0.87	0.90
	3/4	5 1/2	1.0	0.78	0.94

For SI: 1 inch = 25.4 mm.

<sup>1</sup>The load reduction factors in this table are applicable to the allowable loads shown in Table 1.

<sup>2</sup>Reduction factors are cumulative. Multiple reduction factors for more than one spacing or edge distance are calculated separately and multiplied.

<sup>3</sup>Load reduction factors for anchors loaded in tension or shear with spacing between critical and minimum are obtained by linear interpolation.

**TABLE 4—IBC AND IRC ALLOWABLE TENSION AND SHEAR LOADS FOR CARBON STEEL TITEN HD SCREW ANCHORS INSTALLED IN TOP OF GROUT-FILLED CMU MASONRY<sup>1</sup>**

ANCHOR MATERIAL	ANCHOR DIA. (in)	DRILL BIT DIA. (in)	MINIMUM EMBEDMENT DEPTH (in)	ANCHOR LOCATION <sup>2</sup> (in)			IBC AND IRC ALLOWABLE LOADS <sup>3,4</sup> (lbf)		
				Minimum Edge Distance	Minimum End Distance	Minimum Spacing	Tension	Shear	
								Parallel to Edge of Masonry Wall	Perpendicular to Edge of Masonry Wall
CARBON STEEL	1/2	1/2	4 1/2	1 3/4	8	8	570	585	160
	5/8	5/8	4 1/2	1 3/4	10	10	570	675	160

For SI: 1 inch = 25.4 mm, 1 pound = 4.45 N, 1 psi = 6.89 kPa.

<sup>1</sup>The allowable tension and shear loads in Table 4 are applicable when anchors are installed in structures regulated by the IRC or IBC.

<sup>2</sup>Minimum edge and end distances are measured from the anchor centerline to the edge and end of the CMU masonry wall, respectively. Refer to Figure 3. Minimum spacing is measured from center-to-center of two anchors. Anchors installed in the mortared head joint are outside the scope of this report.

<sup>3</sup>The allowable loads in Table 4 are for anchors resisting dead, live, wind, and earthquake load applications.

<sup>4</sup>Allowable tension and shear loads are based on a safety factor of 5.0.

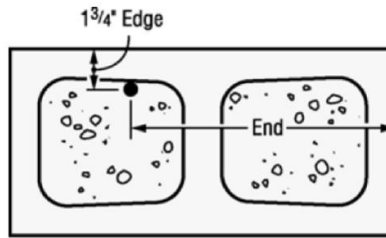

FIGURE 3—EDGE AND END DISTANCES FOR THE CARBON STEEL TITEN HD ANCHOR INSTALLED IN THE TOP OF GROUT-FILLED CMU MANSORY WALL CONSTRUCTION (Refer to Table 4)

TABLE 5—IBC AND IRC ALLOWABLE TENSION AND SHEAR LOADS FOR STAINLESS STEEL TITEN HD SCREW ANCHORS INSTALLED IN THE FACE OF HOLLOW CMU MASONRY CONSTRUCTION<sup>1</sup>

ANCHOR MATERIAL	ANCHOR DIA. <sup>2</sup> (in.)	DRILL BIT DIA. (in.)	MIN. EMBED. <sup>3</sup> (in.)	ANCHOR LOCATION <sup>4</sup> (in.)				ALLOWABLE LOADS BASED ON ANCHORS INSTALLED AT DISTANCES ≥ CRITICAL EDGE DISTANCE, $C_{crit}$ , AND SPACING, $S_{crit}$ <sup>5</sup> . (lbf)	
				Edge Distance		Spacing		Tension	Shear
				Critical, $C_{crit}$	Minimum, $C_{min}$	Critical, $S_{crit}$	Minimum, $S_{min}$		
STAINLESS STEEL	3/8	3/8	2 1/2	12	4	8	4	185	450
	1/2	1/2	2 1/2	12	4	8	4	205	465
	5/8	5/8	2 1/2	12	4	8	4	110	405
	3/4	3/4	2 1/2	12	4	8	4	155	395

For SI: 1 inch = 25.4 mm, 1 psi = 6.89 kPa, 1 lbf = 4.48 N.

<sup>1</sup> Anchors must be installed a minimum of 1 1/4 inches from vertical head joints and T-joints. Refer to [Figure 4](#) for permitted and prohibited anchor installation locations.

<sup>2</sup> The drill bit diameter must be equal to the nominal diameter of the anchor. Anchor installation must comply with Section 4.0 of this report.

<sup>3</sup> Embedment depth is measured from the outside face of the masonry.

<sup>4</sup> Critical and minimum edge distances,  $C_{crit}$  and  $C_{min}$ , respectively, must comply with this table. Refer to [Figure 4](#). Critical and minimum spacing,  $S_{crit}$  and  $S_{min}$ , respectively, must comply with this table. Critical and minimum edge and spacing distances are valid for anchors resisting tension or shear loads. Refer to [Table 6](#) for allowable tension and shear load reduction factors for anchors installed between critical and minimum edge distances, and to [Table 7](#) for anchors installed between critical and minimum spacing.

<sup>5</sup> Tabulated allowable loads are based on a safety factor of 5.0.

TABLE 6—LOAD REDUCTION FACTORS FOR STAINLESS STEEL TITEN HD SCREW ANCHORS INSTALLED BETWEEN CRITICAL AND MINIMUM EDGE DISTANCES (Anchors Installed in the Face of Hollow CMU Masonry)<sup>1,2,3</sup>

ANCHOR MATERIAL	ANCHOR DIAMETER (in)	MINIMUM EMBEDMENT DEPTH (in)	LOAD REDUCTION FACTORS FOR ANCHORS INSTALLED AT:		
			Critical Edge Distance, $C_{crit}$	Minimum Edge Distance, $C_{min}$	
			Tension or Shear Load	Tension Load	Shear Load
STAINLESS STEEL	3/8	2 1/2	1.0	1.0	0.78
	1/2	2 1/2	1.0	1.0	0.63
	5/8	2 1/2	1.0	1.0	0.55
	3/4	2 1/2	1.0	1.0	0.51

For SI: 1 inch = 25.4 mm.

<sup>1</sup> The load reduction factors in this table are applicable to the allowable loads shown in [Table 5](#).

<sup>2</sup> Reduction factors are cumulative. Multiple reduction factors for more than one spacing or edge distance are calculated separately and multiplied.

<sup>3</sup> Load reduction factors for anchors loaded in tension or shear with edge distances between critical and minimum are obtained by linear interpolation.

**TABLE 7—LOAD REDUCTION FACTORS FOR STAINLESS STEEL TITEN HD SCREW ANCHORS INSTALLED BETWEEN CRITICAL AND MINIMUM SPACING (Anchors Installed in the Face of Hollow CMU Masonry)<sup>1,2,3</sup>**

ANCHOR MATERIAL	ANCHOR DIAMETER (in)	MINIMUM EMBEDMENT DEPTH (in)	LOAD REDUCTION FACTORS FOR ANCHORS INSTALLED AT:					
			Critical Spacing, $S_{crit}$	Minimum Spacing, $S_{min}$				
				Tension or Shear Load	Tension Load		Shear Load	
					1 anchor per cell	2 anchors per cell	1 anchor per cell	2 anchors per cell
STAINLESS STEEL	$\frac{3}{8}$	$2\frac{1}{2}$	1.0	0.72	1.0	0.81	0.76	
	$\frac{1}{2}$	$2\frac{1}{2}$	1.0	0.87	1.0	1.0	1.0	
	$\frac{5}{8}$	$2\frac{1}{2}$	1.0	0.89	1.0	0.71	0.75	
	$\frac{3}{4}$	$2\frac{1}{2}$	1.0	0.70	0.78	0.74	0.75	

For SI: 1 inch = 25.4 mm.

<sup>1</sup>The load reduction factors in this table are applicable to the allowable loads shown in Table 5.

<sup>2</sup>Reduction factors are cumulative. Multiple reduction factors for more than one spacing or edge distance are calculated separately and multiplied.

<sup>3</sup>Load reduction factors for anchors loaded in tension or shear with spacing between critical and minimum are obtained by linear interpolation.

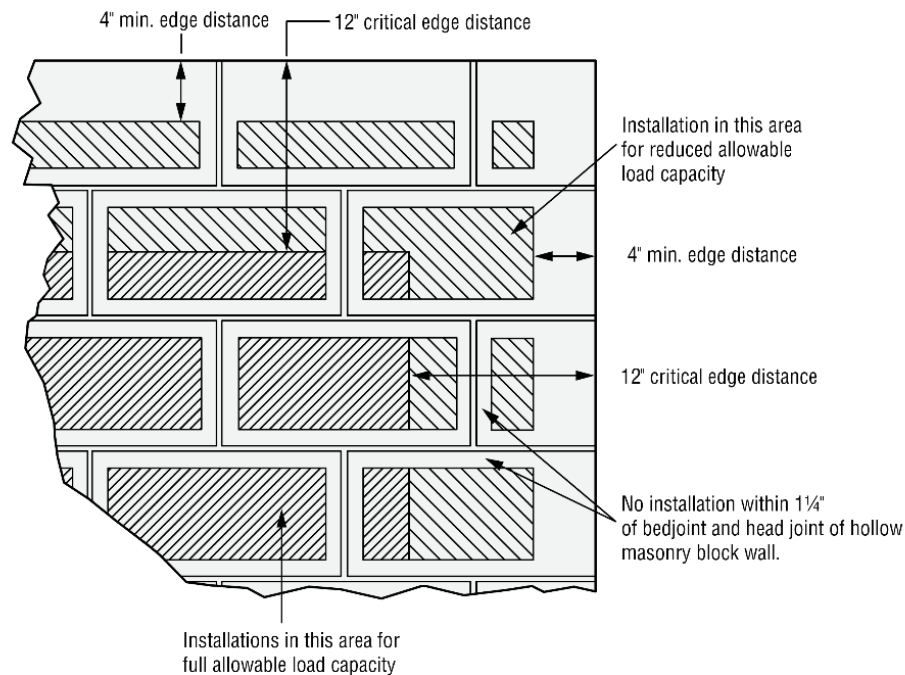

**FIGURE 4—STAINLESS STEEL TITEN HD SCREW ANCHOR INSTALLED IN THE FACE OF HOLLOW CMU (CONCRETE MANSORY UNIT) WALL CONSTRUCTION (Refer to Table 5, 6 and 7)**

**TABLE 8—IBC AND IRC ALLOWABLE TENSION AND SHEAR LOADS FOR CARBON STEEL TITEN HD SCREW ANCHORS INSTALLED IN END OF GROUT-FILLED CMU MASONRY<sup>1</sup>**

ANCHOR MATERIAL	ANCHOR DIA. (in)	DRILL BIT DIA. (in)	MINIMUM EMBEDMENT DEPTH (in)	ANCHOR LOCATION <sup>2</sup> (in)			IBC AND IRC ALLOWABLE LOADS <sup>3,4</sup> (lbf)		
				Minimum Edge Distance	Minimum End Distance	Minimum Spacing	Tension	Shear	
								Vertical to Masonry Wall	Horizontal to Masonry Wall
CARBON STEEL	$\frac{1}{4}$	$\frac{1}{4}$	$2\frac{3}{8}$	$3\frac{13}{16}$	$1\frac{3}{4}$	4	310	215	375
	$\frac{3}{8}$	$\frac{3}{8}$	$2\frac{3}{8}$	$3\frac{13}{16}$	$1\frac{3}{4}$	6	335	215	375

For SI: 1 inch = 25.4 mm, 1 pound = 4.45 N, 1 psi = 6.89 kPa.

<sup>1</sup>The allowable tension and shear loads in Table 8 are applicable when anchors are installed in structures regulated by the IRC or IBC.

<sup>2</sup>Minimum edge and end distances are measured from the anchor centerline to the edge and end of the CMU masonry wall, respectively. Refer to Figure 5. Minimum spacing is measured from center-to-center of two anchors.

<sup>3</sup>The allowable loads in Table 8 are for anchors resisting dead, live, wind, and earthquake load applications.

<sup>4</sup>Allowable tension and shear loads are based on a safety factor of 5.0.



**TABLE 9—IBC AND IRC ALLOWABLE TENSION AND SHEAR LOADS FOR CARBON STEEL TITEN HD SCREW ANCHORS INSTALLED IN END OF HOLLOW CMU MASONRY<sup>1,5</sup>**

ANCHOR MATERIAL	ANCHOR DIA. (in)	DRILL BIT DIA. (in)	MINIMUM EMBEDMENT DEPTH (in)	ANCHOR LOCATION <sup>2</sup> (in)			IBC AND IRC ALLOWABLE LOADS <sup>3,4</sup> (lbf)		
				Minimum Edge Distance	Minimum End Distance	Minimum Spacing	Tension	Shear	
								Vertical to Masonry Wall	Horizontal to Masonry Wall
CARBON STEEL	1/4	1/4	2 <sup>3</sup> / <sub>8</sub>	3 <sup>13</sup> / <sub>16</sub>	1 <sup>3</sup> / <sub>4</sub>	4	130	105	120
	3/8	3/8	2 <sup>3</sup> / <sub>8</sub>	3 <sup>13</sup> / <sub>16</sub>	1 <sup>3</sup> / <sub>4</sub>	6	130	115	125

For SI: 1 inch = 25.4 mm, 1 pound = 4.45 N, 1 psi = 6.89 kPa.

<sup>1</sup>The allowable tension and shear loads in Table 9 are applicable when anchors are installed in structures regulated by the IRC or IBC.

<sup>2</sup>Minimum edge and end distances are measured from the anchor centerline to the edge and end of the CMU masonry wall, respectively. Refer to Figure 6. Minimum spacing is measured from center-to-center of two anchors.

<sup>3</sup>The allowable loads in Table 9 are for anchors resisting dead, live, wind and earthquake load applications in structures assigned to Seismic Design Categories A and B only under the IBC.

<sup>4</sup>Allowable tension and shear loads are based on a safety factor of 5.0.

<sup>5</sup>Anchors must be installed a minimum of 1 1/2 inches from centerline of bed joints. Refer to Figure 6 for prohibited anchor installation locations.

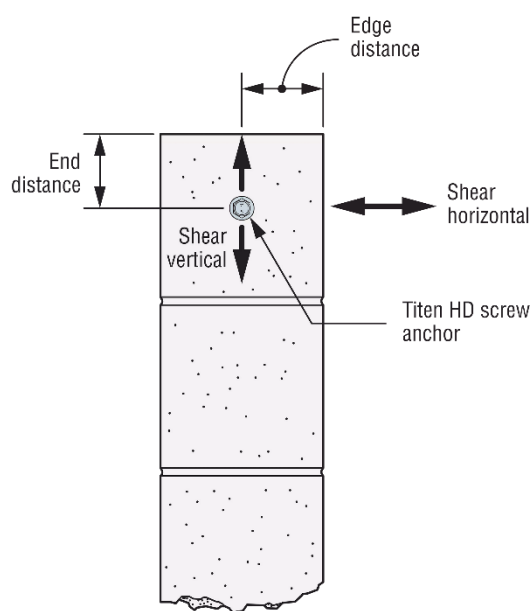

**FIGURE 5—EDGE AND END DISTANCES FOR THE CARBON STEEL TITEN HD ANCHOR INSTALLED IN THE END OF GROUT-FILLED A CMU MANSORY WALL CONSTRUCTION (Refer to Table 8)**

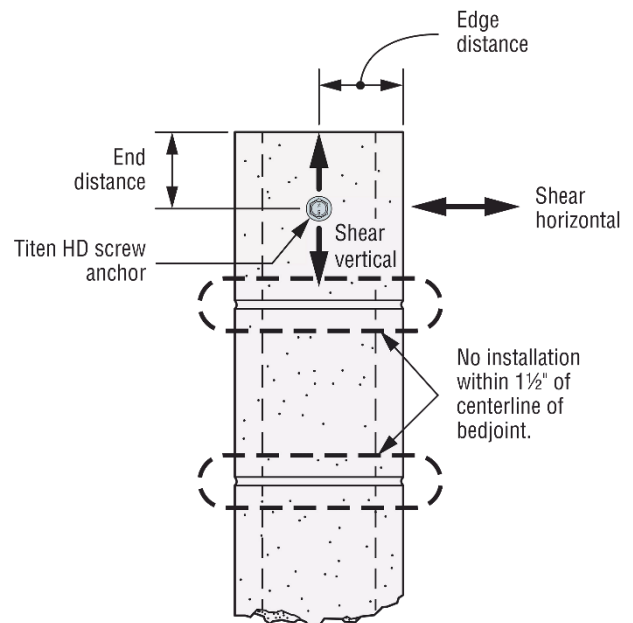

**FIGURE 6—EDGE AND END DISTANCES FOR THE CARBON STEEL TITEN HD ANCHOR INSTALLED IN THE END OF HOLLOW CMU MANSORY WALL CONSTRUCTION (Refer to Table 9)**

**DIVISION: 04 00 00—MASONRY**  
**Section: 04 05 19.16—Masonry Anchors**

**REPORT HOLDER:**

**SIMPSON STRONG-TIE COMPANY INC.**

**EVALUATION SUBJECT:**

**SIMPSON STRONG-TIE TITEN HD® SCREW ANCHORS**

**1.0 REPORT PURPOSE AND SCOPE****Purpose:**

The purpose of this evaluation report supplement is to indicate that the Simpson Strong-Tie Titen HD screw anchors, described in ICC-ES evaluation report [ESR-1056](#), have also been evaluated for compliance with the codes noted below as adopted by Los Angeles Department of Building and Safety (LADBS).

**Applicable code editions:**

- 2023 *City of Los Angeles Building Code* (LABC)
- 2023 *City of Los Angeles Residential Code* (LARC)

**2.0 CONCLUSIONS**

The Simpson Strong-Tie Titen HD screw anchors, described in Sections 2.0 through 7.0 of the evaluation report [ESR-1056](#), comply with LABC Chapter 21, and LARC, and are subjected to the conditions of use described in this report.

**3.0 CONDITIONS OF USE**

The Simpson Strong-Tie Titen HD screw anchors described in this evaluation report supplement must comply with all of the following conditions:

- All applicable sections in the evaluation report [ESR-1056](#).
- The design, installation, conditions of use and identification of the anchors are in accordance with the 2021 *International Building Code*® (IBC) provisions noted in the evaluation report [ESR-1056](#).
- The design, installation and inspection are in accordance with additional requirements of LABC Chapters 16 and 17
- Under the LARC, an engineered design in accordance with LARC Section R301.1.3 must be submitted.
- The allowable design values listed in the evaluation report and tables are for the connection of the anchors to the masonry substrate. The connection between the anchors and the connected members must be checked for capacity (which may govern).
- For use in wall anchorage assemblies to flexible diaphragm applications, anchors must be designed per the requirements of City of Los Angeles Information Bulletin P/BC 2020-071.

This supplement expires concurrently with the evaluation report ESR-1056, reissued March 2023.

**DIVISION: 04 00 00—MASONRY**  
**Section: 04 05 19.16—Masonry Anchors**

**REPORT HOLDER:**

**SIMPSON STRONG-TIE COMPANY INC.**

**EVALUATION SUBJECT:**

**SIMPSON STRONG-TIE TITEN HD® SCREW ANCHORS**

**1.0 REPORT PURPOSE AND SCOPE****Purpose:**

The purpose of this evaluation report supplement is to indicate that Simpson Strong-Tie Titen HD® screw anchors, described in ICC-ES evaluation report ESR-1056, have also been evaluated for compliance with the codes noted below.

**Applicable code editions:**

- 2023 *Florida Building Code—Building*
- 2023 *Florida Building Code—Residential*

**2.0 CONCLUSIONS**

The Simpson Strong-Tie Titen HD® screw anchors, described in Sections 2.0 through 7.0 of ICC-ES evaluation report ESR-1056, comply with the *Florida Building Code—Building* and the *Florida Building Code—Residential*. The design requirements must be determined in accordance with the *Florida Building Code—Building* or the *Florida Building Code—Residential*, as applicable. The installation requirements noted in ICC-ES evaluation report ESR-1056 for the 2021 *International Building Code*® meet the requirements of the *Florida Building Code—Building* or the *Florida Building Code—Residential*, as applicable.

Use of the Simpson Strong-Tie Titen HD® screw anchors have also been found to be in compliance with the High-Velocity Hurricane Zone provisions of the *Florida Building Code—Building* and the *Florida Building Code—Residential*, with the following condition:

- a) Design and installation must meet the requirements of Section 2122.7 of the *Florida Building Code—Building*.

For products falling under Florida Rule 61G20-3, verification that the report holder's quality assurance program is audited by a quality assurance entity approved by the Florida Building Commission for the type of inspections being conducted is the responsibility of an approved validation entity (or the code official when the report holder does not possess an approval by the Commission).

This supplement expires concurrently with the evaluation report, reissued March 2023 and revised August 2023.