

# LSC

## Adjustable Stringer Connector

The LSC adjustable stair-stringer connector offers a versatile, concealed connection between the stair stringer and the carrying header or rim board while replacing costly framing. Field slopeable to all common stair stringer pitches, the LSC connector is suitable for either solid or notched stringers.

### Features:

- Replaces additional framing and toe-nailing.
- May be installed flush with the top of the carrying member (typically suitable for 2x10 or 2x12 header / rim board) or lower on the face (typically suitable for a 2x12 header / rim board).
- Interchangeable for left or right applications.
- LSCZ features a ZMAX® coating for additional corrosion protection. Suitable for interior and some exterior applications. LSCSS is made from stainless steel for higher exposure environment. See [strongtie.com/info](http://strongtie.com/info) for more information.

**Material:** 18 gauge

**Finish:** LSCZ — ZMAX coating; LSCSS — stainless steel

### Installation:

- Use all specified fasteners, see table.
- Before fastening, position the stair stringer with the LSC on the carrying member to verify where the bend should be located.
- The fastener that is installed into the bottom edge of the stringer must go into the second-to-last hole.
- When installed on 1 $\frac{5}{16}$ " LVL or a 1 $\frac{1}{4}$ " LSL stringer, additional items that will not affect the structural performance of the LSC, but should be considered, include the following:
  - LSC stringer flange will protrude  $\frac{1}{4}$ " from face of stringer. As such, it is recommended the LSC be installed with the tabs positioned to the outside of the stringer.
  - 1 $\frac{1}{2}$ " fasteners installed into 1 $\frac{1}{4}$ " LSL stringer will protrude from the opposite side.

**Codes:** See p. 13 for Code Reference Key Chart

### Web Applications:

- Visit [app.strongtie.com/dps](http://app.strongtie.com/dps) to access our Deck Planner Software™.
- Visit [app.strongtie.com/hs](http://app.strongtie.com/hs) to access our Hanger Selector web application.

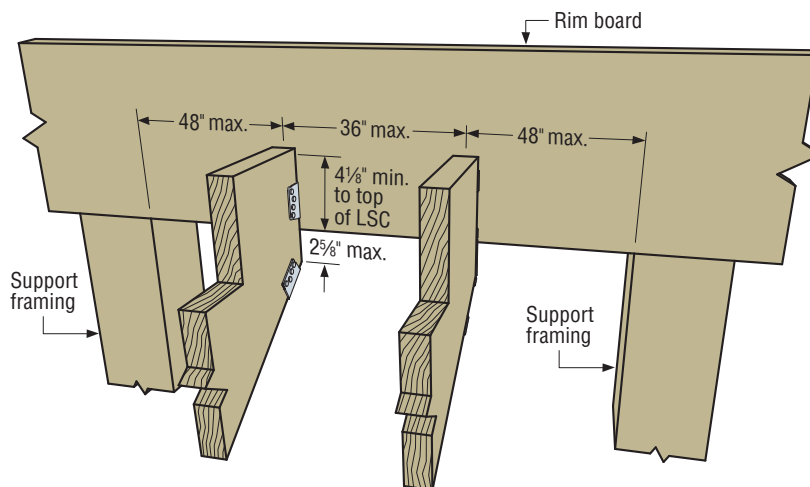
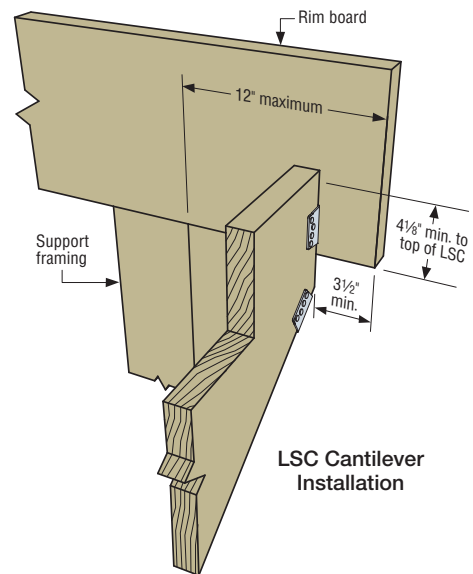
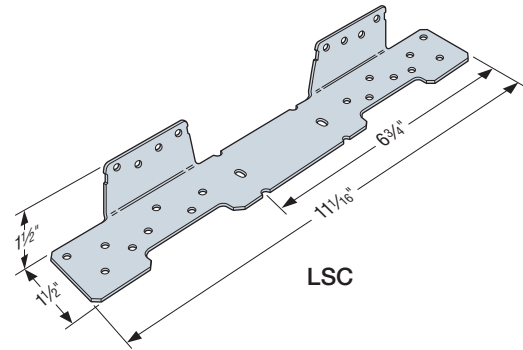

Standard LSC Installation

# LSC

## Adjustable Stringer Connector (cont.)

These products are available with additional corrosion protection. For more information, see p. 16.

**SS** For stainless-steel fasteners, see p. 23.

**SD** Many of these products are approved for installation with Strong-Drive® SD Connector screws. See pp. 362–366 for more information.

Model No.	Rim Board Installation	Fastener Schedule			DF/SP Allowable Loads		SPF/HF Allowable Loads		Code Ref.
		Rim Board	Stringer Wide Face	Stringer Narrow Face	Floor (100)	Snow (115)	Floor (100)	Snow (115)	
<b>SS</b> LSCZ LSCSS	Supported	(8) 0.148 x 1 1/2	(8) 0.148 x 1 1/2	(1) 0.148 x 1 1/2	945	960	815	825	IBC®, FL, LA
	Supported	(8) #9 x 1 1/2" SD	(8) #9 x 1 1/2" SD	—	865	865	670	670	
	Standard	(8) 0.148 x 1 1/2	(8) 0.148 x 1 1/2	(1) 0.148 x 1 1/2	755	755	650	650	
	Standard	(8) #9 x 1 1/2" SD	(8) #9 x 1 1/2" SD	(1) #9 x 1 1/2" SD	755	755	650	650	
	Cantilever	(8) 0.148 x 1 1/2	(8) 0.148 x 1 1/2	(1) 0.148 x 1 1/2	460	460	395	395	
	Cantilever	(8) #9 x 1 1/2" SD	(8) #9 x 1 1/2" SD	—	545	545	445	445	

- When installed on minimum 1 5/8" LVL or minimum 1 1/4" LSL stringers, allowable loads for DF/SP shall apply.
- When cross-grain bending or cross-grain tension cannot be avoided in the members, mechanical reinforcement to resist such forces shall be considered by the designer.
- #9 x 1 1/2" Strong-Drive SD Connector screws may be substituted for 0.148" x 1 1/2" nails to achieve published nail values if the extra screw is installed in the narrow face of the stringer.
- When LSC is installed at end of rim board over support framing, use standard load.
- Fasteners:** Nail dimensions are listed diameter by length. SD screws are Simpson Strong-Tie Strong-Drive SD Connector screws. See pp. 23–24 for fastener information.

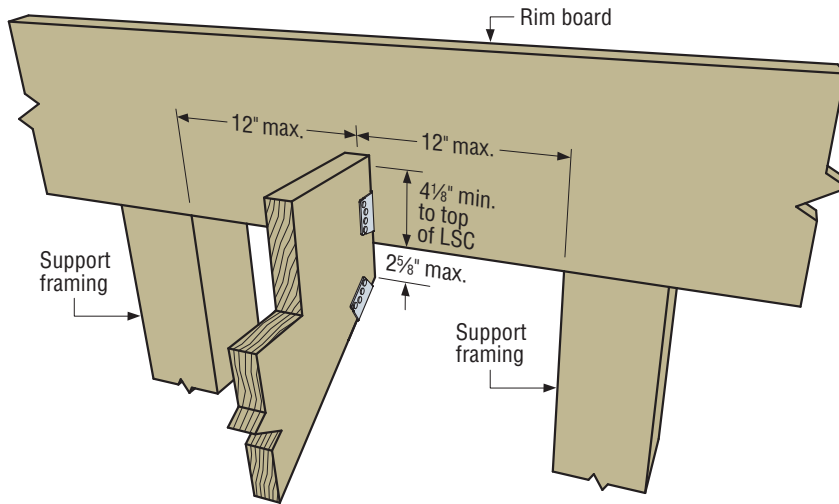

Supported LSC Installation