

BuckleBridge®

Bridging System

Material Composition

ASTM A1003/A1003M Structural Grade 50 (340) Type H, ST50H (ST340H): 50ksi (340MPa) minimum yield strength, 65ksi (450MPa) minimum tensile strength, 33mil minimum thickness (20 gauge, 0.0346" design thickness) with ASTM A653/A653M G90 (Z275) hot dipped galvanized coating.

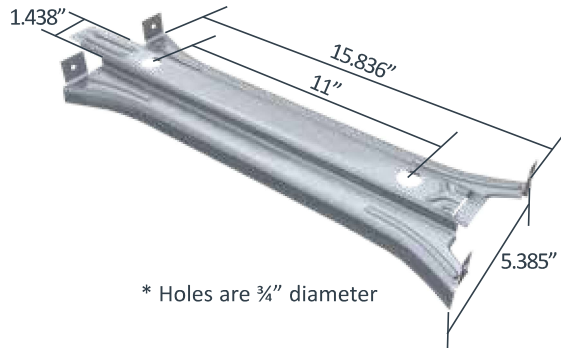

US Patents #7,596,921, #7,836,657 & #8,205,402
Load Direction

BuckleBridge Allowable Loads

BuckleBridge® Allowable Loads						
Studs 16" o.c.	Axially Loaded Studs				Laterally Loaded Studs	
	Compression Brace		Tension Brace		6" Studs	8" Studs
	F1 (lbs)	Stiffness (lbs/in)	F1 (lbs)	Stiffness (lbs/in)	M1 (in-lb)	M1 (in-lb)
	2,400	31,000	440	2,560	1,290	967

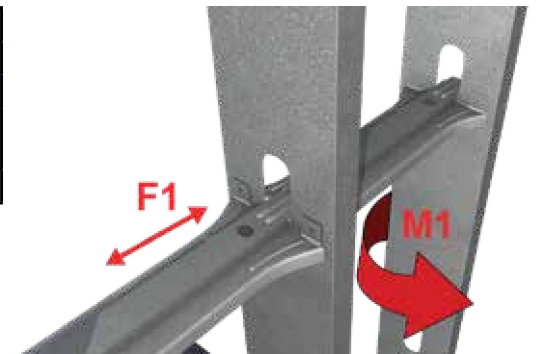

Nomenclature

BuckleBridge comes in one size and is designated *BuckleBridge*®. It is used with 16" o.c. member spacing.

Example Details



When using BuckleBridge in curtain walls with standard "cee" studs, one screw is only needed every 3rd stud.*



BuckleBridge used in load bearing walls with TSN's SigmaStud



BuckleBridge works just as easily with back-to-back studs.

Notes:

- Resists weak axis buckling and torsional rotation of members.
- Spaces studs automatically at 16" o.c. Suitable for 6" & 8" walls.
- Elongated tabs in one end of BuckleBridge lock into a slot at the other end through the stud knockout.
- * Use (1) #10 screw on alternate sides of the BuckleBridge at 3rd stud (48" o.c.) Use (2) #10 screws at end of wall run.