

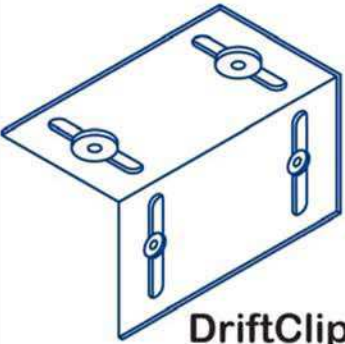

DriftClip® DSL Installation Instructions

Vertical Deflection & Drift @ Head of Wall



DriftClip® DSL



Large Step Bushing
(Engineered for PAF
to structure)



Standard Step Bushing
(Engineered for #12
screw to stud)

Do not remove step bushings
unless otherwise directed

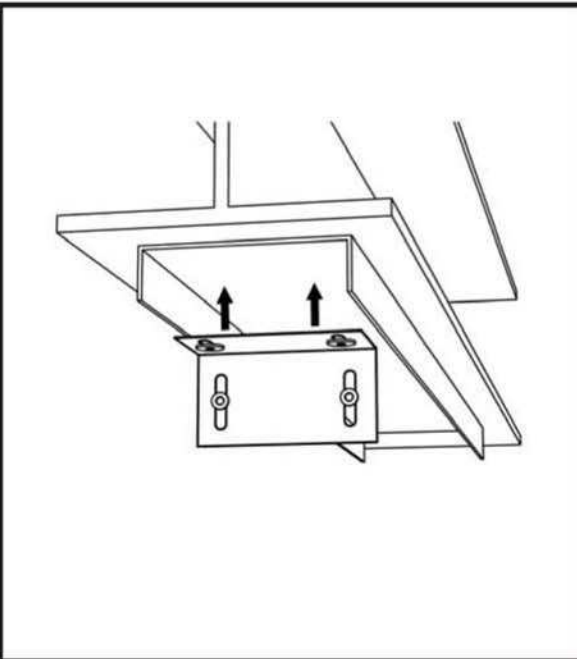
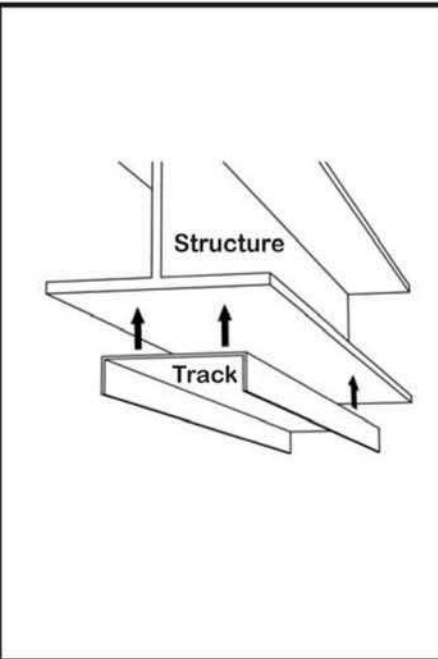

**Attachment to Structure per
Design Specifications**

Fasteners should be
installed through
each step bushing.

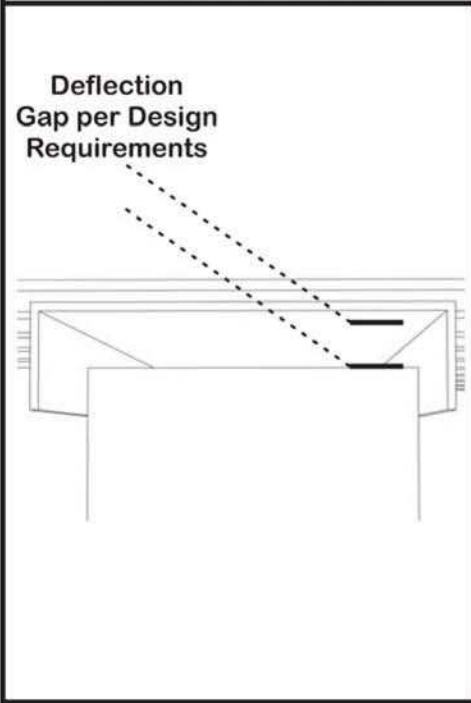
Install screws using a screw gun that
does not exceed 2,500 rpm.

#12 Screw

Fasteners should be installed through each step bushing.
Screw gun must be equipped with torque
limiting clutch to avoid fastener overdrive.

**For Installation, Technical, or
Submittal questions, contact TSN
at (888) 474-4876.**

Email us at tsn@steelnetwork.com.

**Visit www.steelnetwork.com
and discover the value of each
TSN Solution.**